



US00D429676S

**United States Patent** [19]  
**Smith et al.**

[11] **Patent Number: Des. 429,676**

[45] **Date of Patent: \*\* Aug. 22, 2000**

[54] **CAB PROTECTOR FOR A DUMP TRUCK BODY**

4,306,381 12/1981 Presto .  
5,239,753 8/1993 Kalis, Jr. et al. .

[75] Inventors: **Joseph G. Smith**, Howard; **Richard R. Lewellen**, Wooster, both of Ohio

[73] Assignee: **Stahl/Scott Fetzer Company**, Wooster, Ohio

[\*\*] Term: **14 Years**

[21] Appl. No.: **29/102,199**

[22] Filed: **Mar. 19, 1999**

[51] **LOC (7) Cl.** ..... **12-16**

[52] **U.S. Cl.** ..... **D12/196; D12/93; D12/15**

[58] **Field of Search** ..... **D12/196, 14, 15, D12/93, 98; 414/476, 477, 480; 298/11, 30, 23 C, 23 M; 296/56, 57.1**

[56] **References Cited**

**U.S. PATENT DOCUMENTS**

- D. 256,901 9/1980 Carr, Jr. et al. .
- D. 342,930 1/1994 Lewellen et al. .
- D. 345,123 3/1994 Lewellen et al. .
- D. 346,571 5/1994 Lewellen et al. .
- D. 351,816 10/1994 Lewellen et al. .
- D. 351,817 10/1994 Lewellen et al. .
- D. 386,128 11/1997 Gerding et al. .
- D. 393,234 4/1998 Stragier .
- D. 409,524 5/1999 McKinney ..... D12/93
- D. 414,138 9/1999 McKinney ..... D12/98

**OTHER PUBLICATIONS**

Advertisement for Henderson Manufacturing, Division of Willknight, Inc., Manchester, Iowa, Entitled "Spreader and Dump Body Combo Works Year Around", Published on p. 42 of *Government Product News Magazine*, Dec. 1998. Product Brochure for Stahl Landmaster Dump Bodies, Stahl/Scott Fetzer, Wooster, Ohio Published, 1995.

*Primary Examiner*—Melody N. Brown  
*Attorney, Agent, or Firm*—Watts, Hoffmann, Fisher & Heinke, Co., L.P.A.

[57] **CLAIM**

We claim the ornamental design for a cab protector for a dump truck body, as shown and described.

**DESCRIPTION**

FIG. 1 is a perspective view of the cab protector for a dump truck body showing our new design; FIG. 2 is a left side elevational view of the cab protector, the right side elevational view being a mirror image; FIG. 3 is a front elevational view of the cab protector; FIG. 4 is a rear elevational view of the cab protector; FIG. 5 is a top plan view of the cab protector; and, FIG. 6 is a bottom plan view of the cab protector. The broken lines shown are for illustrative purposes only and form no part of the claimed design.

**1 Claim, 3 Drawing Sheets**

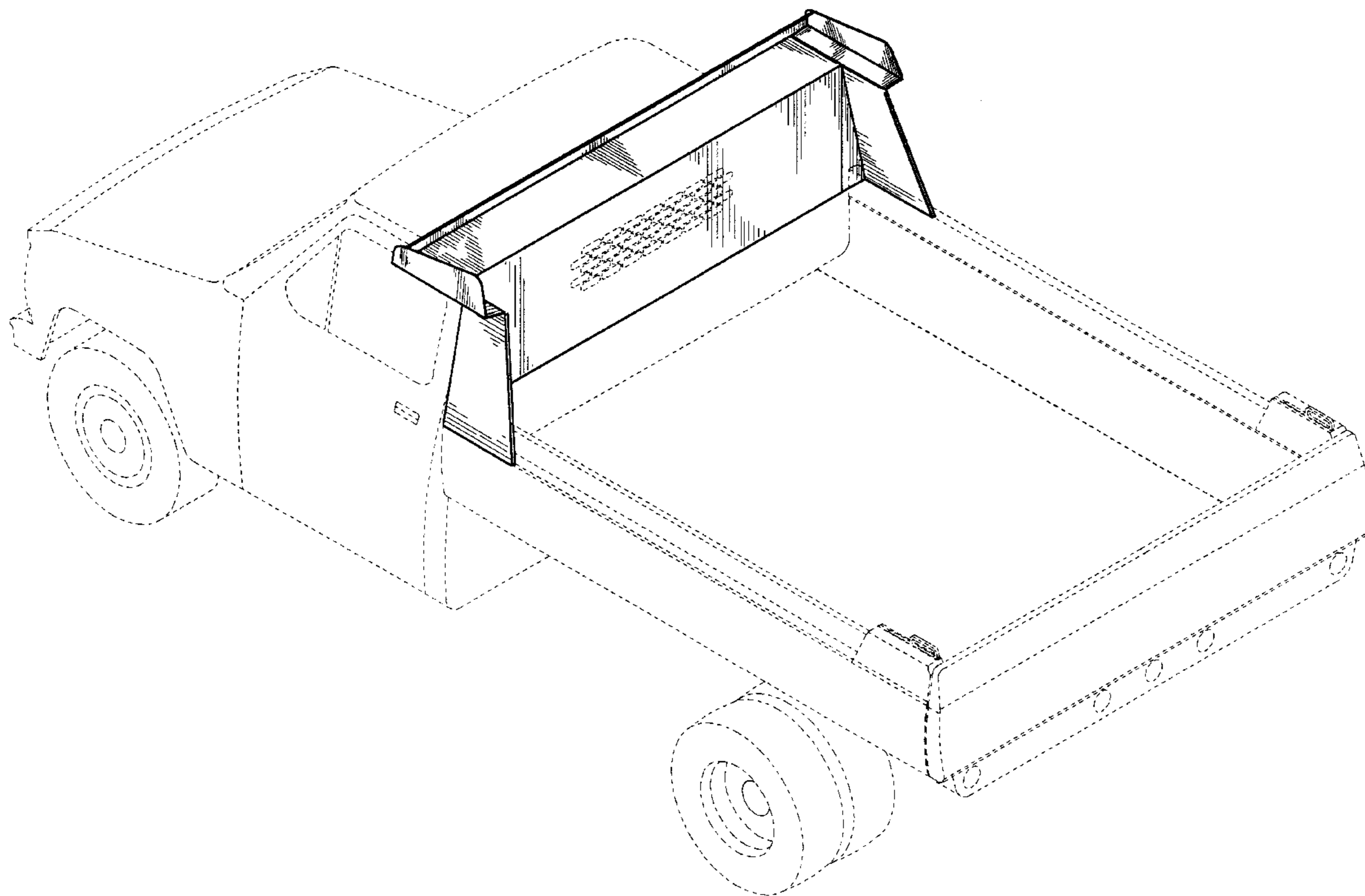

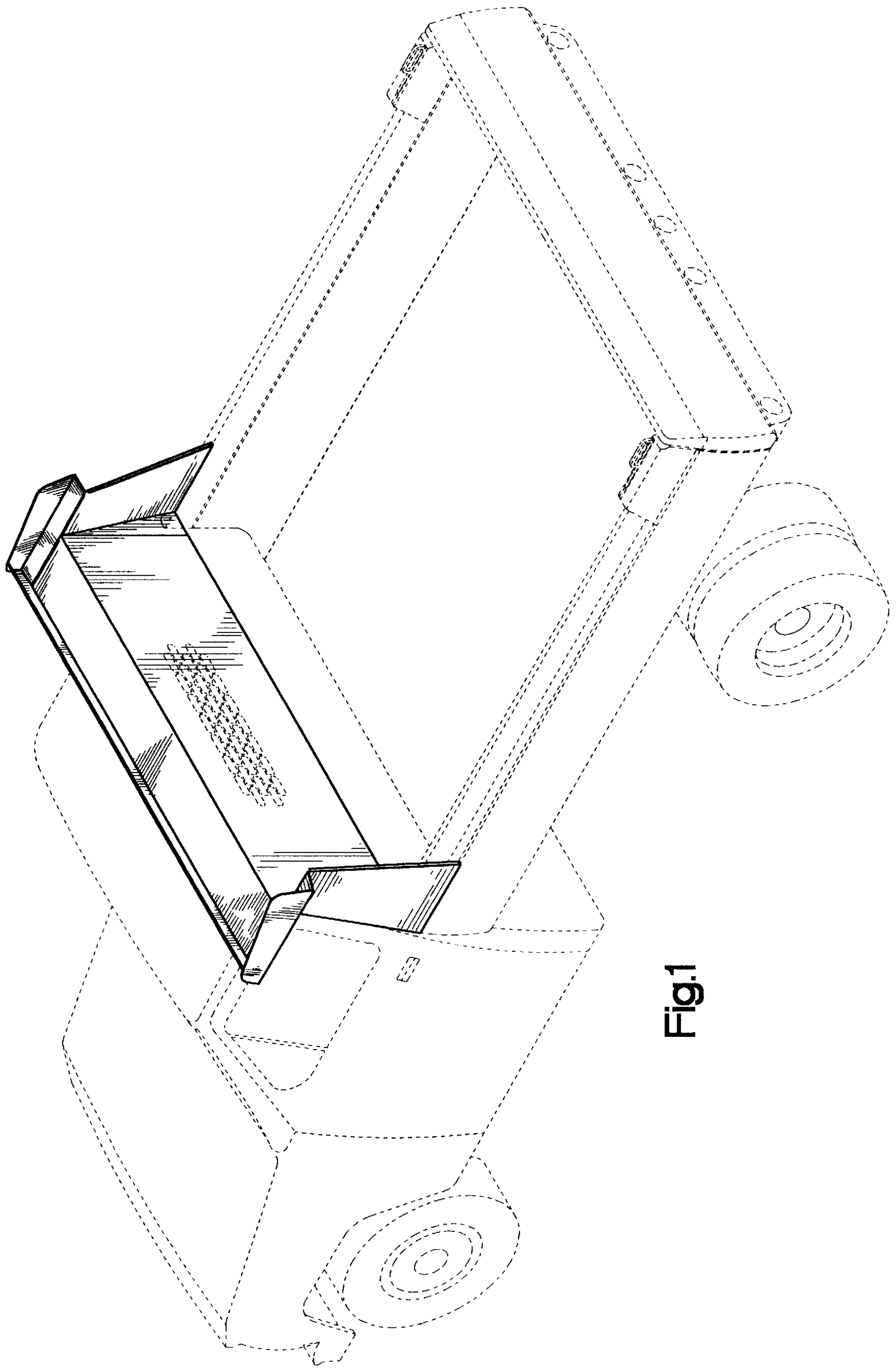

Fig.1

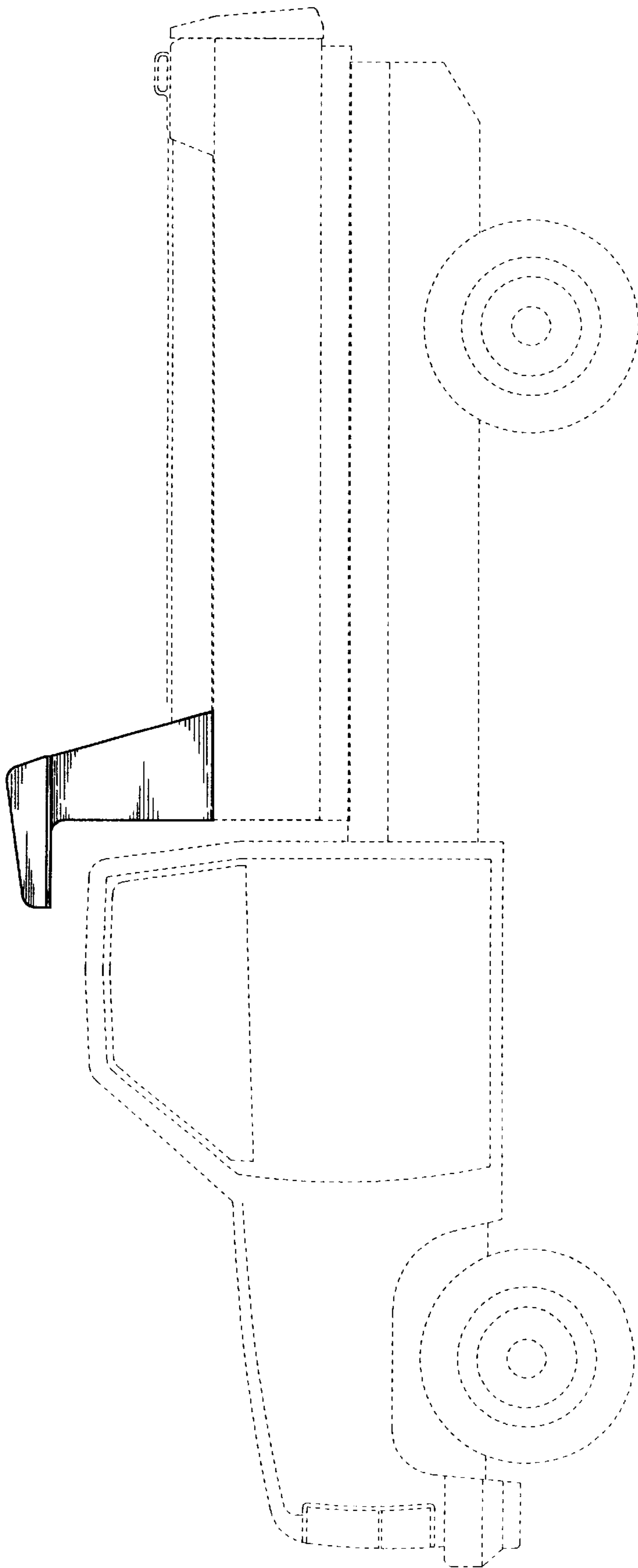

Fig.2

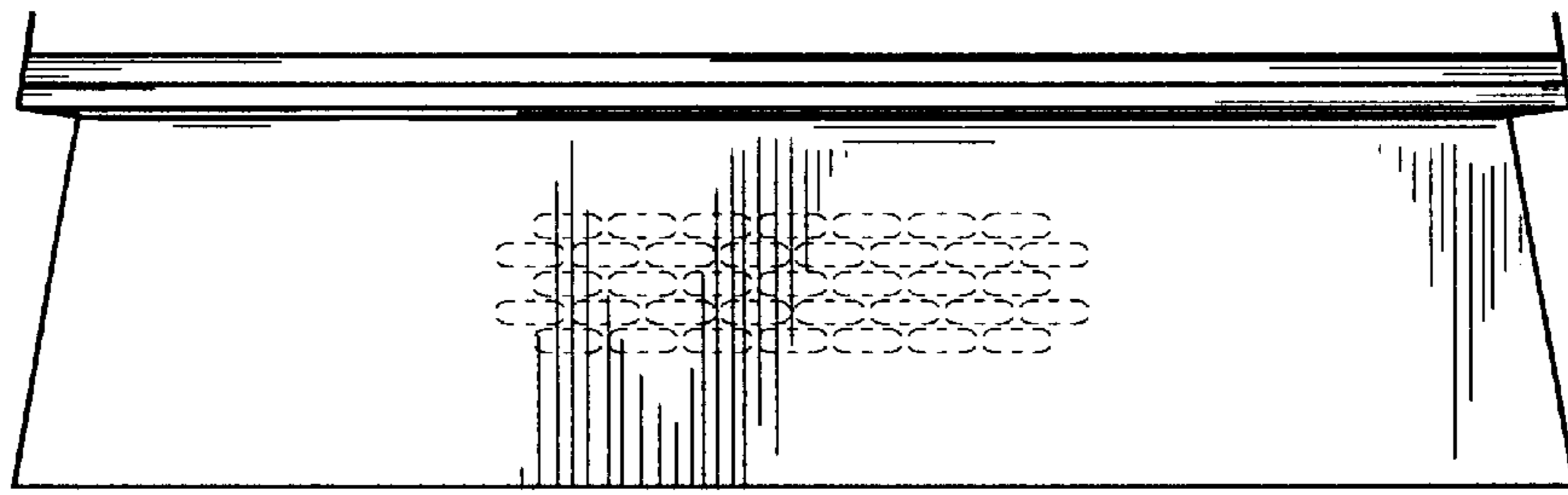

Fig.3

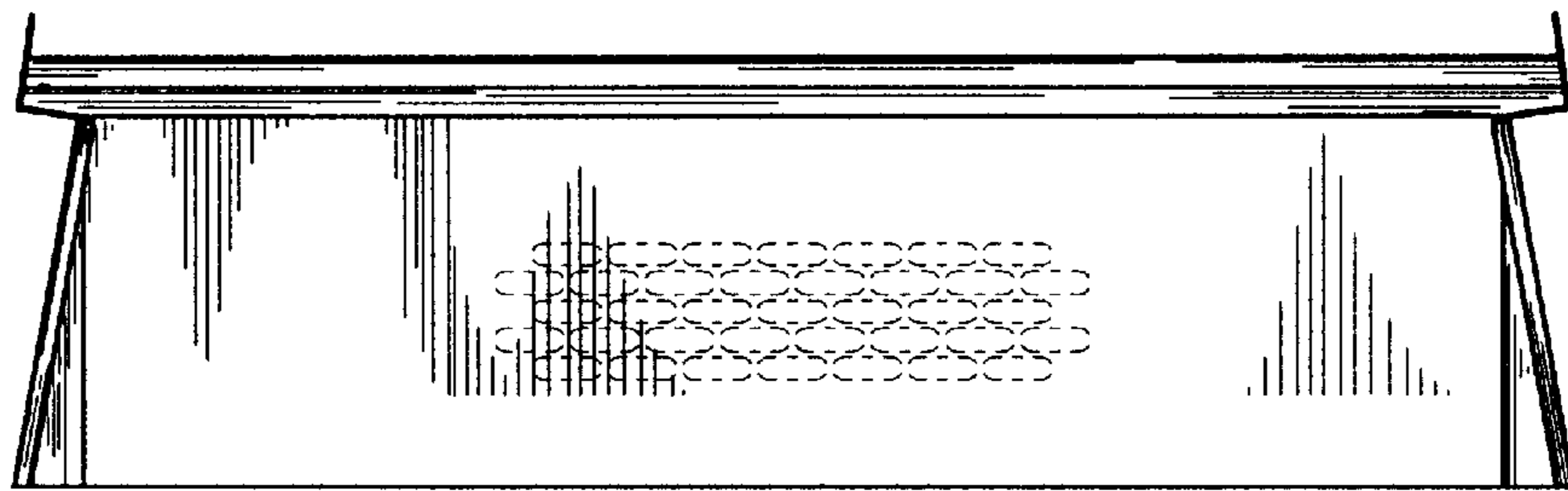

Fig.4

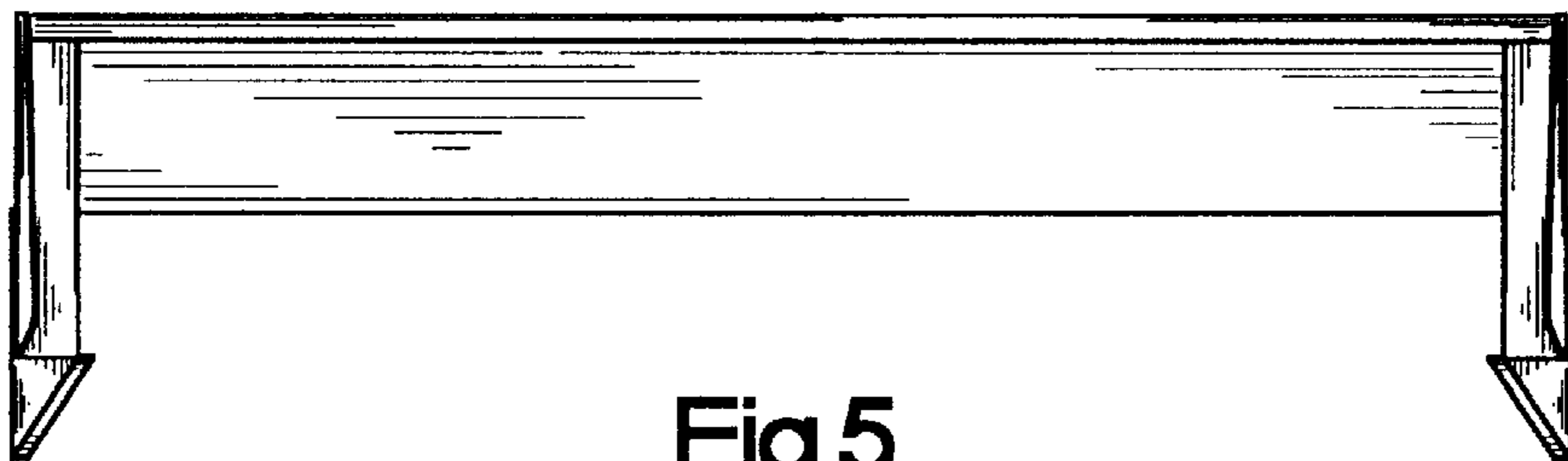

Fig.5

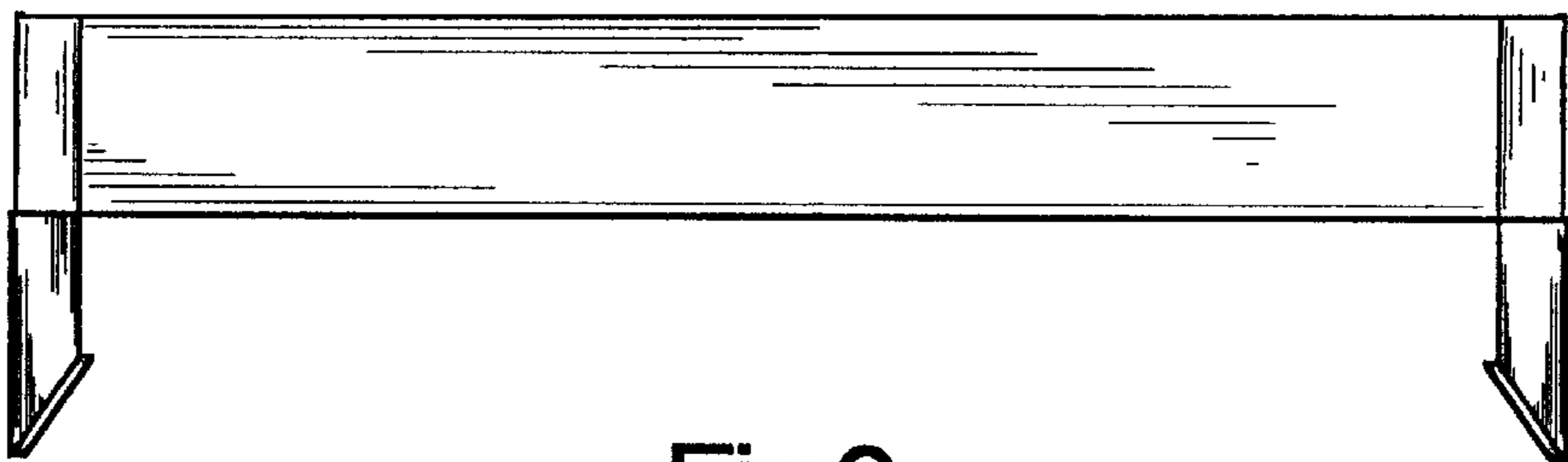

Fig.6