



US00D429663S

# United States Patent [19]

Tamashima et al.

[11] Patent Number: **Des. 429,663**

[45] Date of Patent: **\*\* Aug. 22, 2000**

[54] **OFF-ROAD VEHICLE**

[75] Inventors: **Teruyasu Tamashima; Teruhito Momoi**, both of Akashi, Japan

[73] Assignee: **Kawasaki Jukogyo Kabushiki Kaisha**, Kobe, Japan

[\*\*] Term: **14 Years**

[21] Appl. No.: **29/115,885**

[22] Filed: **Dec. 22, 1999**

### [30] Foreign Application Priority Data

Jun. 24, 1999 [JP] Japan ..... 11-016736

[51] **LOC (7) Cl.** ..... **12-11**

[52] **U.S. Cl.** ..... **D12/107**

[58] **Field of Search** ..... D12/107, 3; 180/233, 180/315, 311, 312, 225, 229

### [56] References Cited

#### U.S. PATENT DOCUMENTS

D. 299,707 2/1989 Makita et al. .... D12/107

D. 327,457 6/1992 Saito ..... D12/107  
D. 330,694 11/1992 Kimura et al. .... D12/107  
D. 383,095 9/1997 Miyamoto et al. .... D12/107  
D. 412,464 8/1999 Ichihara et al. .... D12/107

*Primary Examiner*—Melody N. Brown  
*Attorney, Agent, or Firm*—Marshall, O’Toole, Gerstein, Murray & Borun

### [57] CLAIM

The ornamental design for an off-road vehicle, as shown and described.

### DESCRIPTION

FIG. 1 is a perspective view of an off-road vehicle showing our new design;  
FIG. 2 is a front elevational view thereof;  
FIG. 3 is a rear elevational view thereof;  
FIG. 4 is a top plan view thereof;  
FIG. 5 is a left side elevational view thereof; and,  
FIG. 6 is a right side elevational view thereof.

**1 Claim, 6 Drawing Sheets**

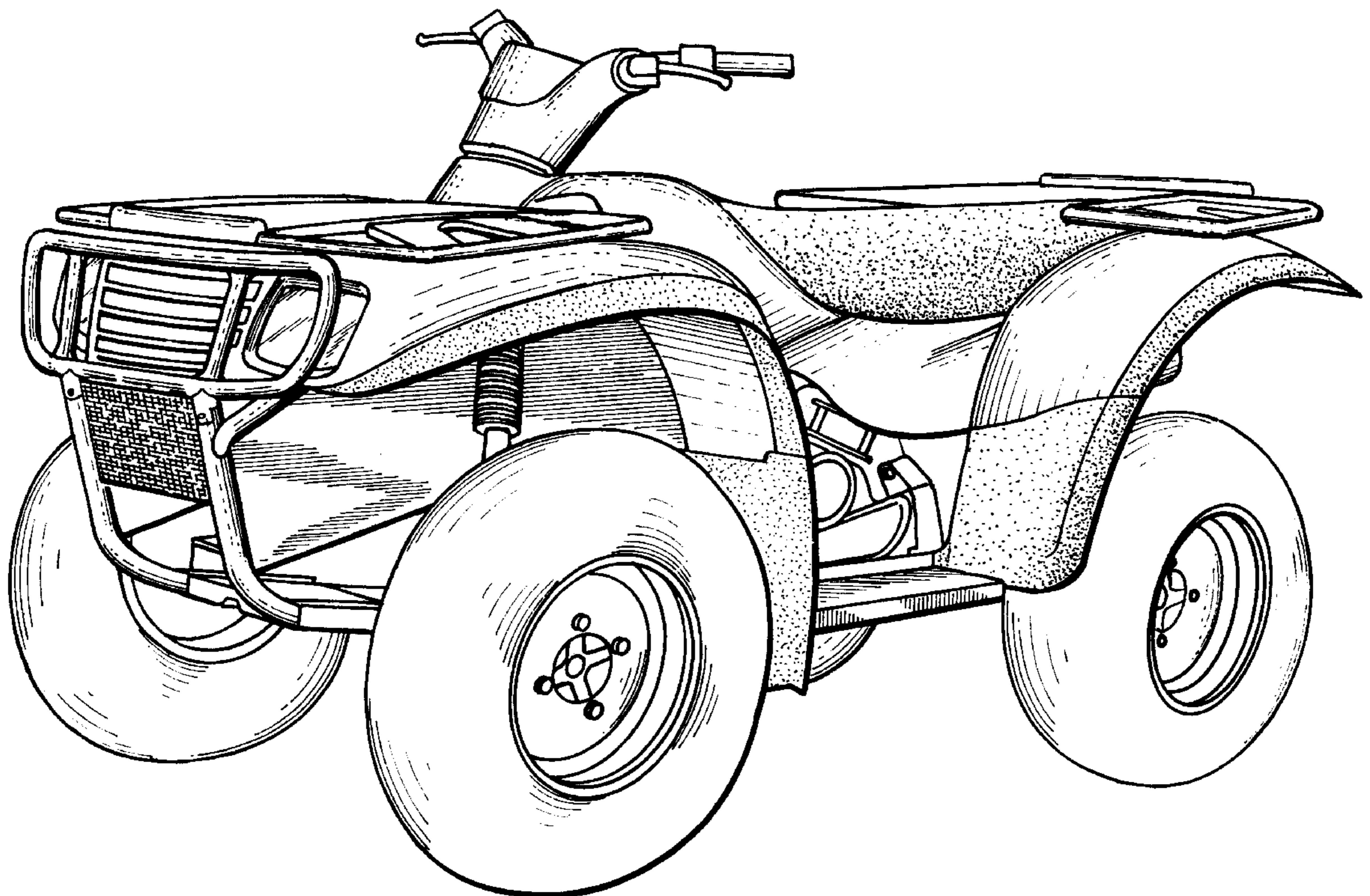

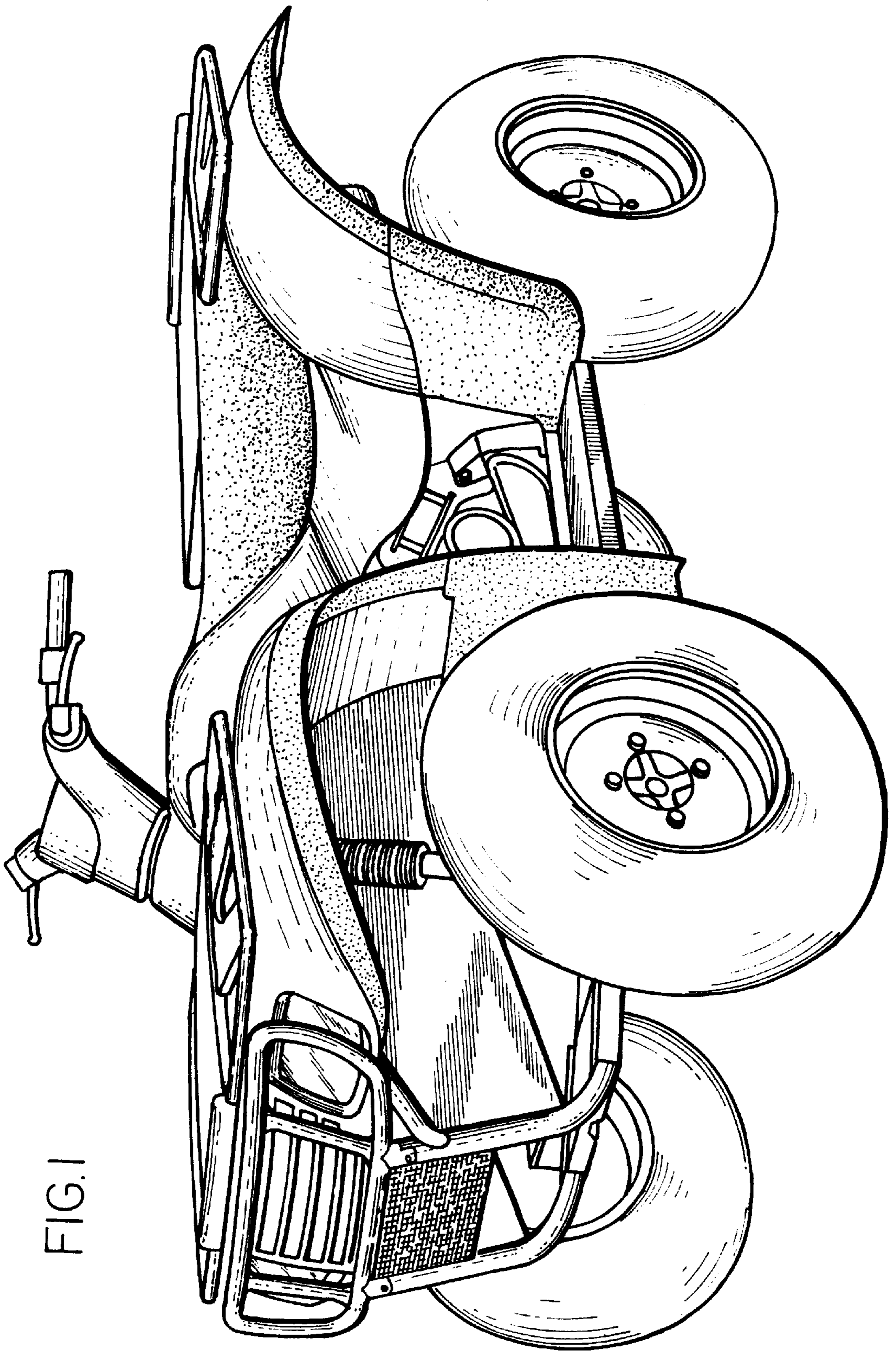

FIG. 1

FIG. 2

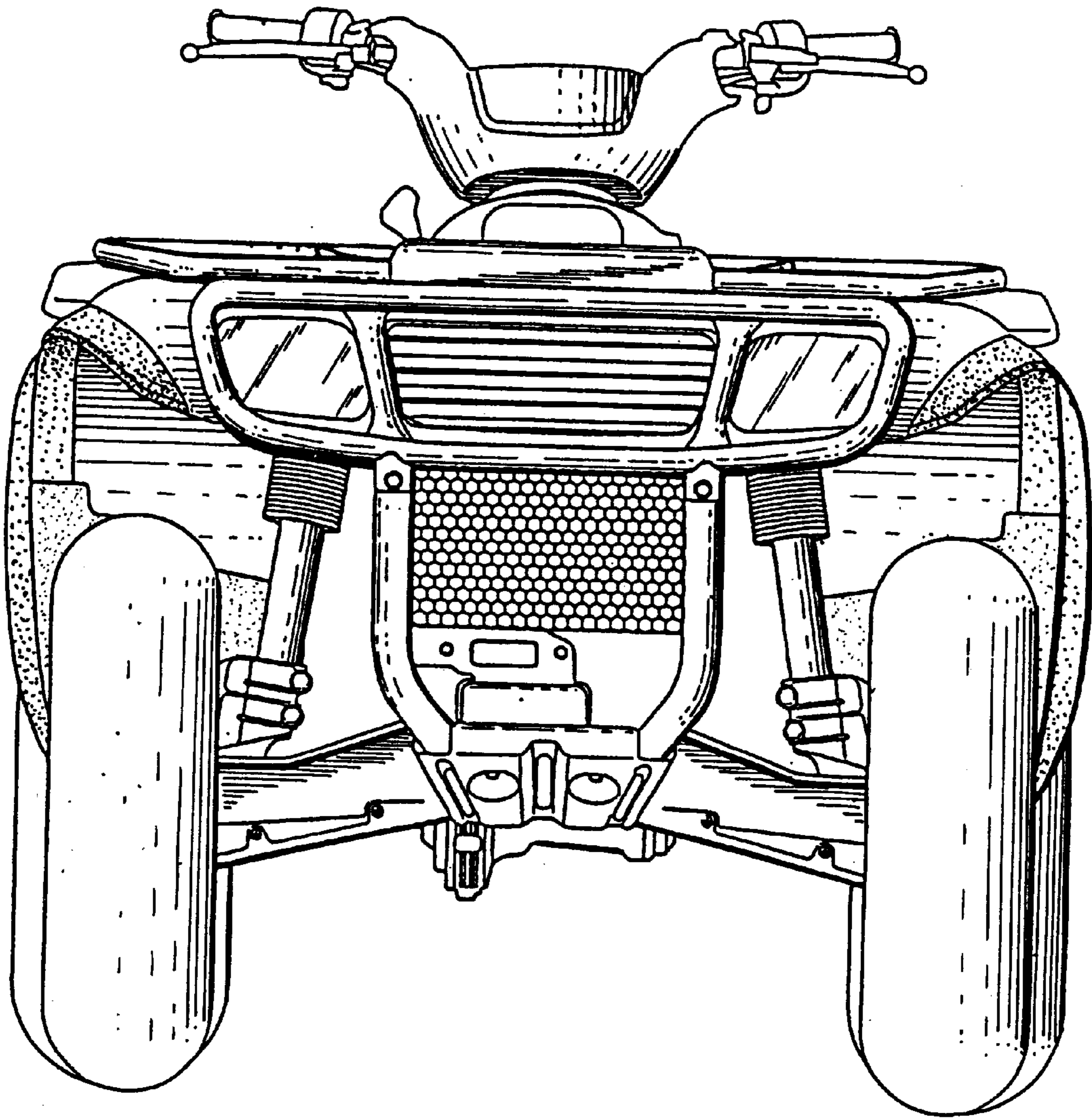

FIG. 3

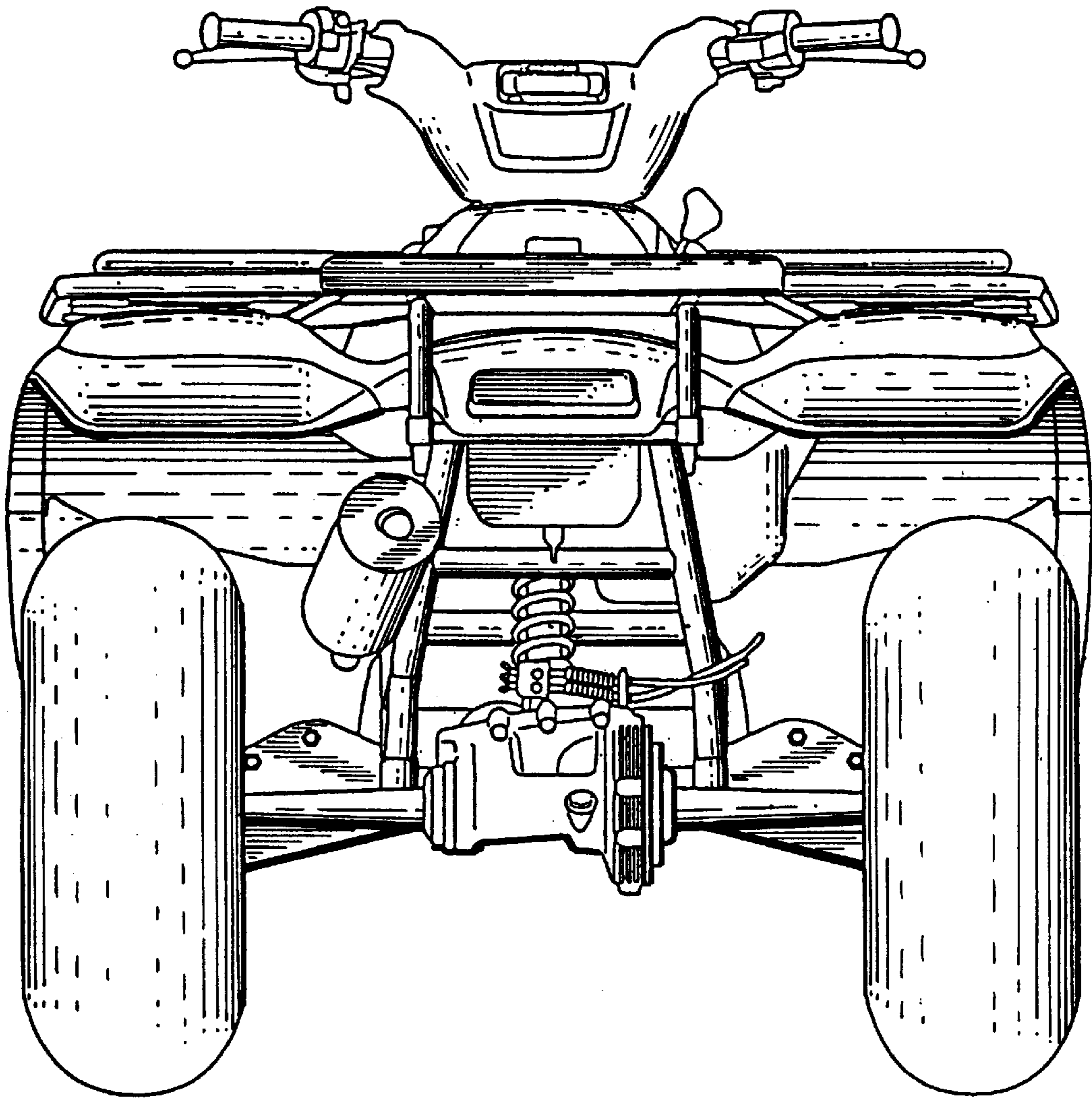

FIG.4

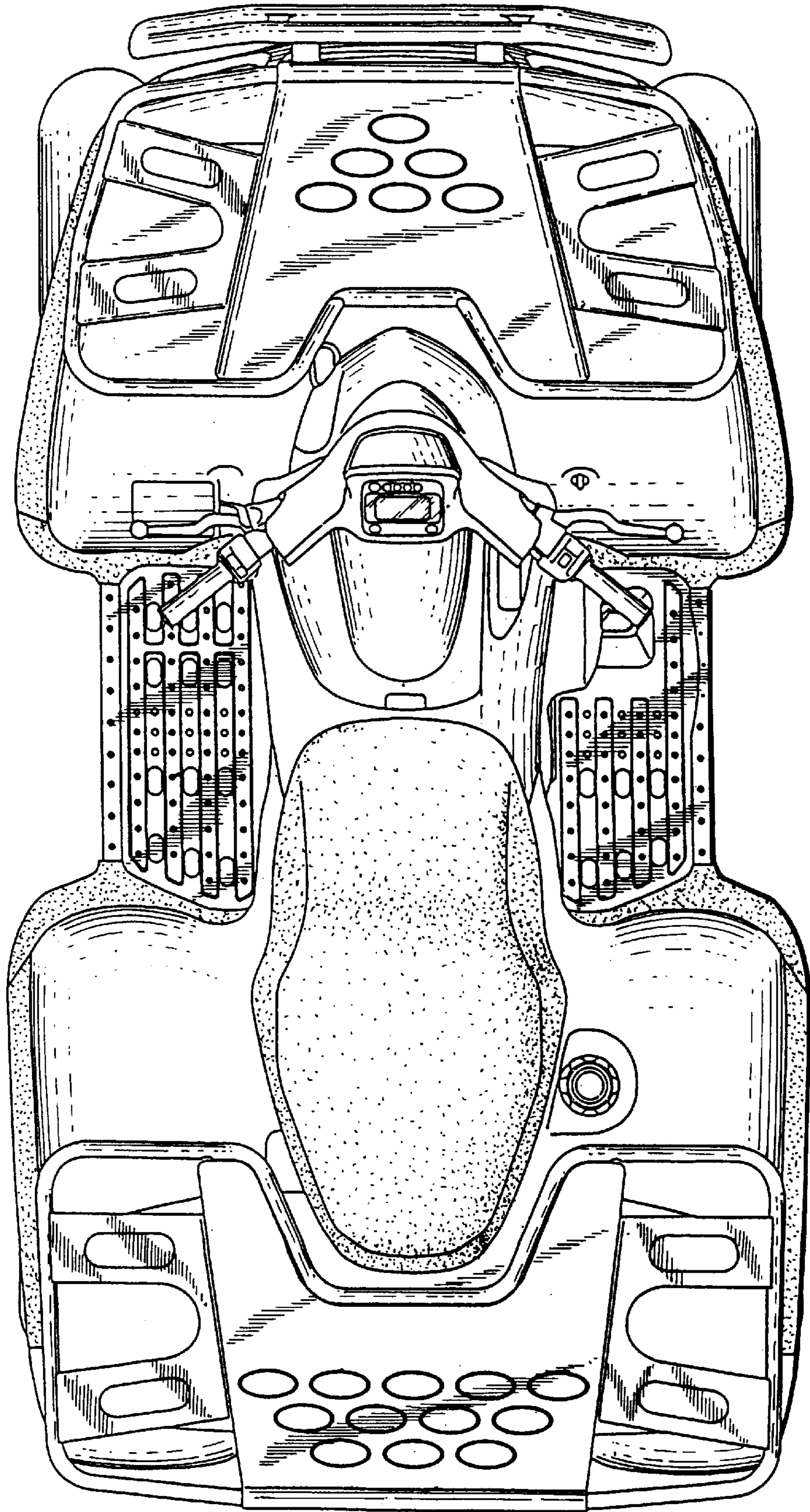
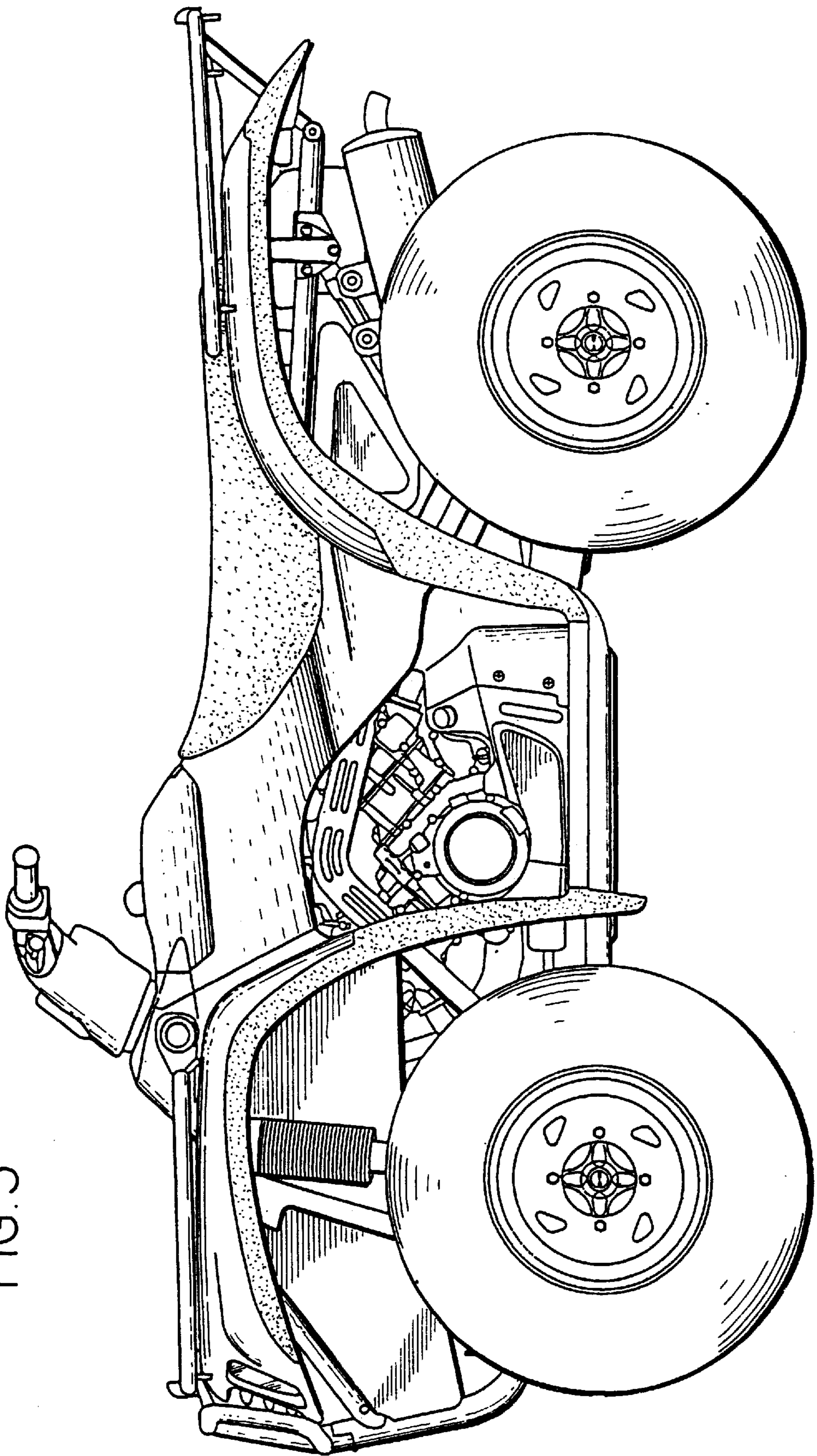

FIG. 5



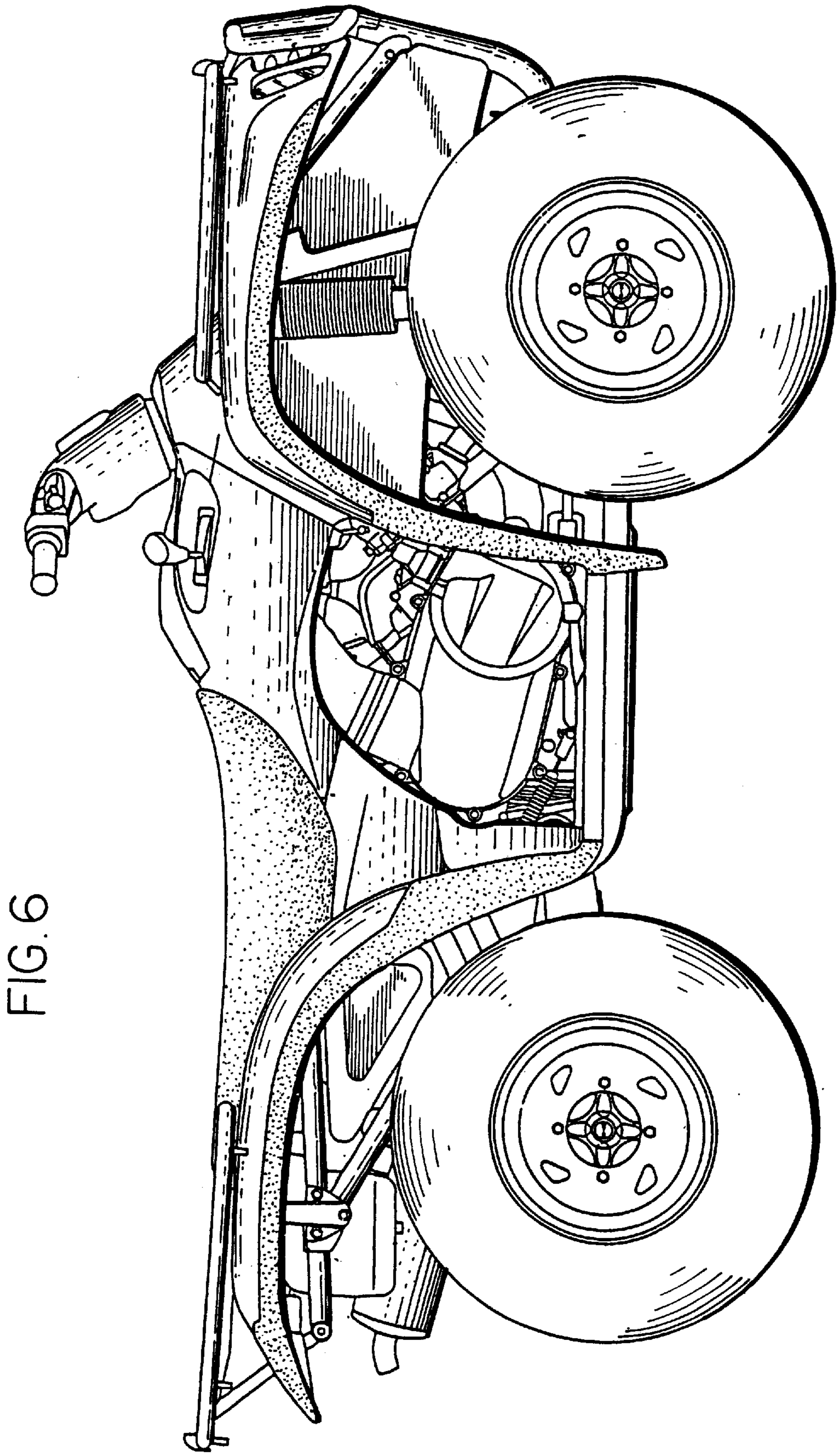

FIG. 6