



US00D429254S

**United States Patent** [19]  
**Bisschop**

[11] **Patent Number: Des. 429,254**

[45] **Date of Patent: \*\* Aug. 8, 2000**

[54] **LIFTER BORE REINFORCEMENT BRACE FOR AUTOMOBILE ENGINES**

[76] Inventor: **David B. Bisschop**, 758 N. Batavia, Unit "J", Orange, Calif. 92868

[\*\*] Term: **14 Years**

[21] Appl. No.: **29/104,886**

[22] Filed: **May 13, 1999**

[51] **LOC (7) Cl.** ..... **15-01**

[52] **U.S. Cl.** ..... **D15/5**

[58] **Field of Search** ..... D15/5; 74/569; 123/90.35, 90.48, 90.5, 90.55

[56] **References Cited**

**U.S. PATENT DOCUMENTS**

D. 387,066 12/1997 Cheek, Sr. .... D15/5

*Primary Examiner*—Ralf Seifert  
*Attorney, Agent, or Firm*—Willie Krawitz

[57] **CLAIM**

The ornamental design for a lifter bore reinforcement brace for automobile engines, as shown and described.

**DESCRIPTION**

FIG. 1 is a top plan view of a lifter bore reinforcement brace for automobile engines, showing my design; FIG. 2 is a front elevation view thereof; FIG. 3 is a rear elevation view thereof; FIG. 4 is a right side elevation view thereof; FIG. 5 is a left side elevation view thereof; FIG. 6 is a bottom plan view thereof; FIG. 7 is a top plan view of a second embodiment of a lifter bore reinforcement brace for automobile engines similar to FIGS. 1-7; FIG. 8 is a front elevation view of FIG. 7; FIG. 9 is a rear elevation view of FIG. 7; FIG. 10 is a right side elevation view of FIG. 7; FIG. 11 is a left side elevation view of FIG. 7; and, FIG. 12 is a bottom plan view of FIG. 7.

The broken line showing in FIGS. 1-5 and 7-11 is illustrative of environmental structure only and forms no part of the claimed design.

**1 Claim, 2 Drawing Sheets**

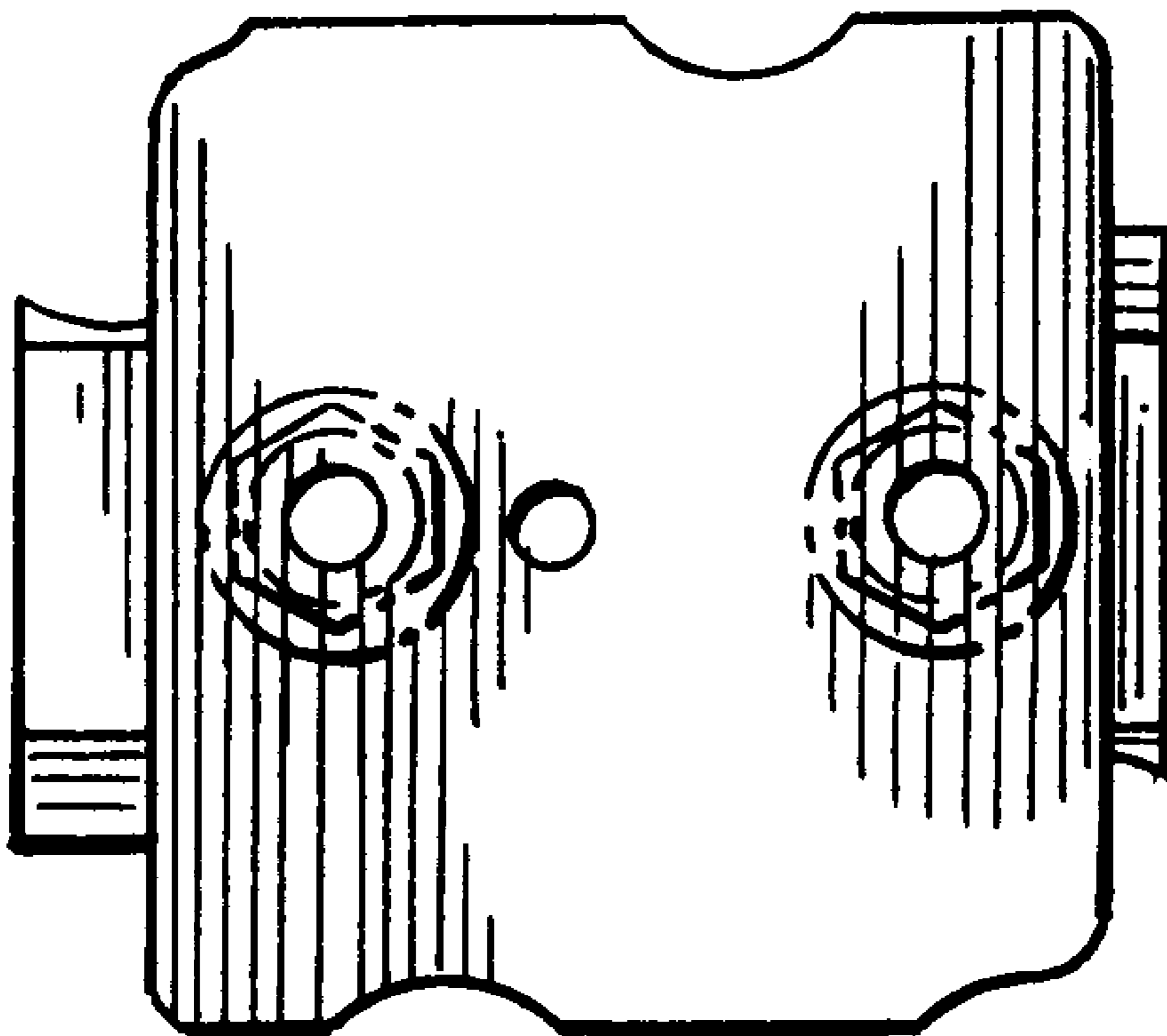

*FIG. 1*

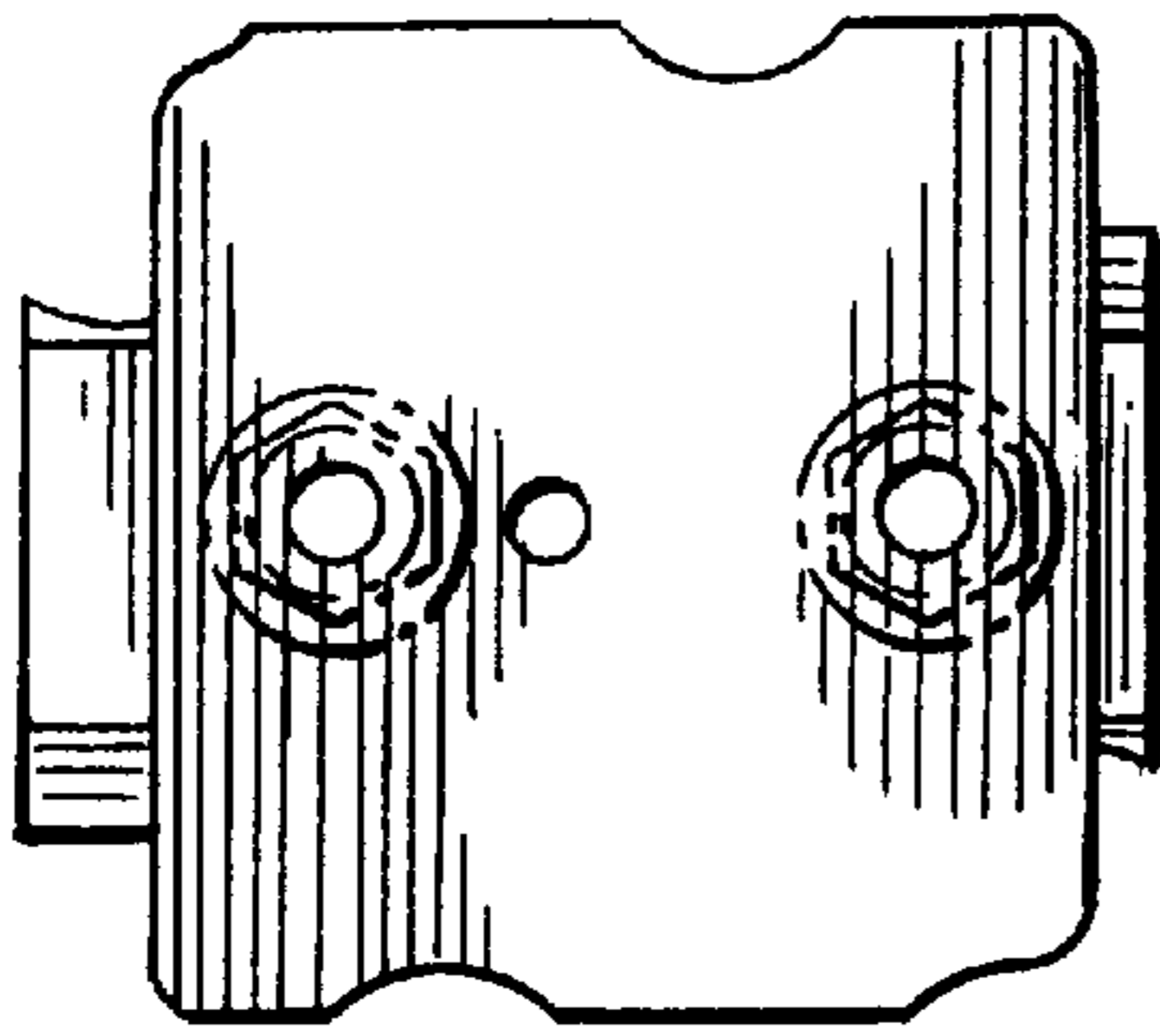

*FIG. 4*

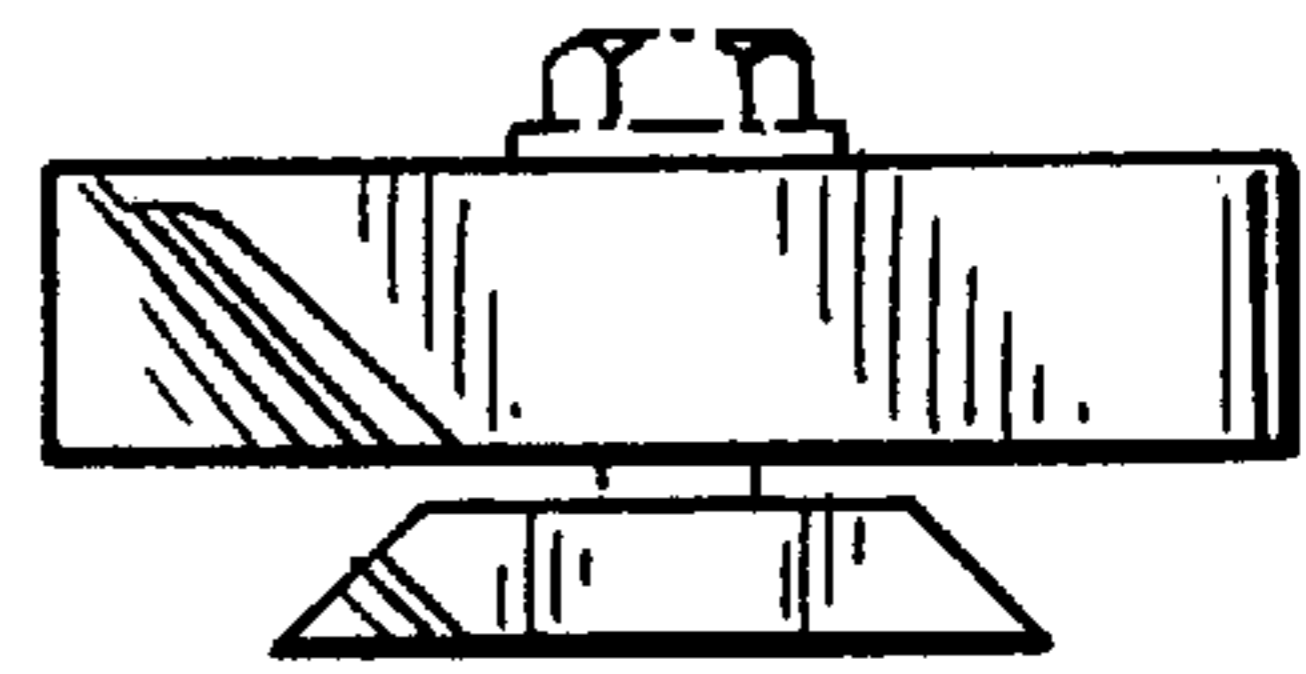

*FIG. 2*

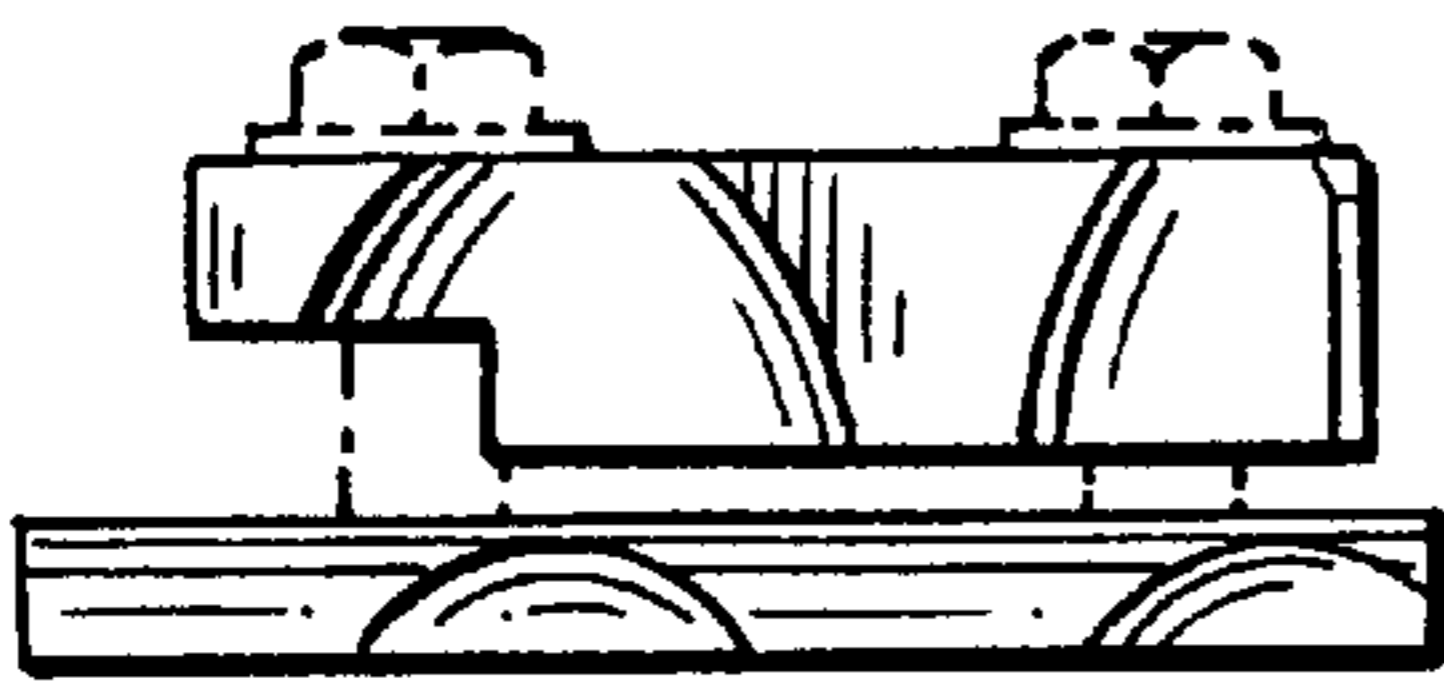

*FIG. 5*

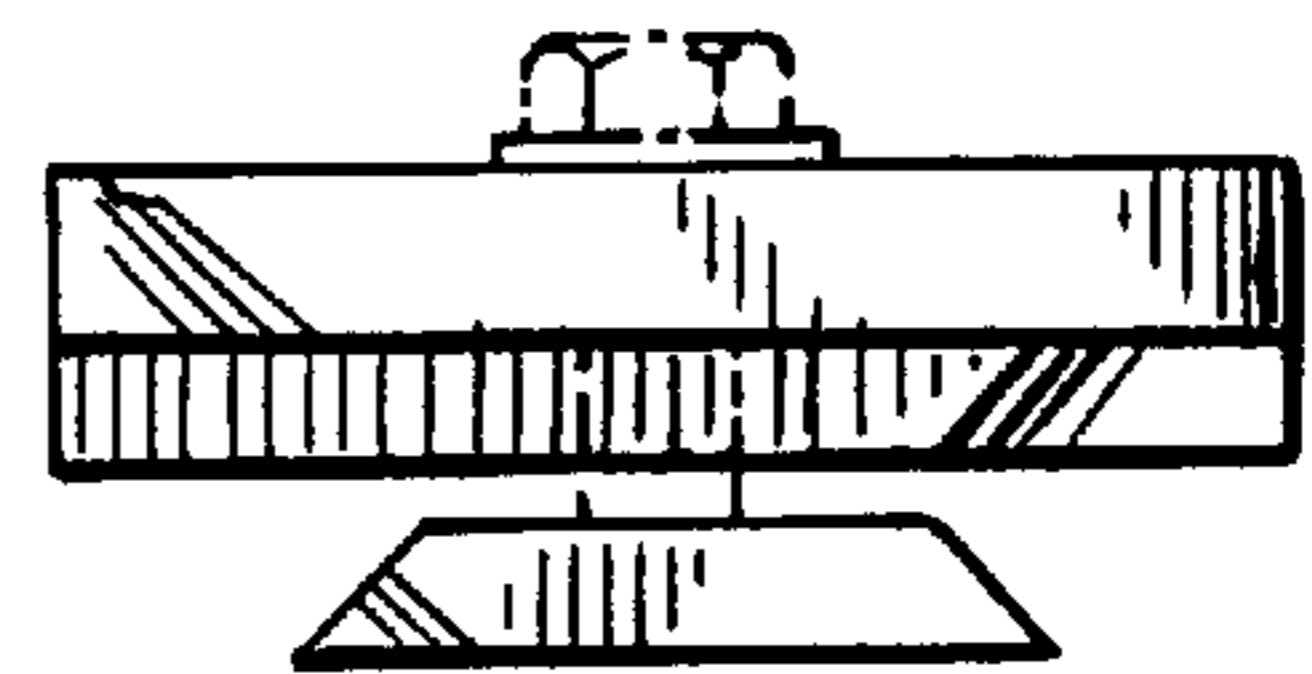

*FIG. 3*

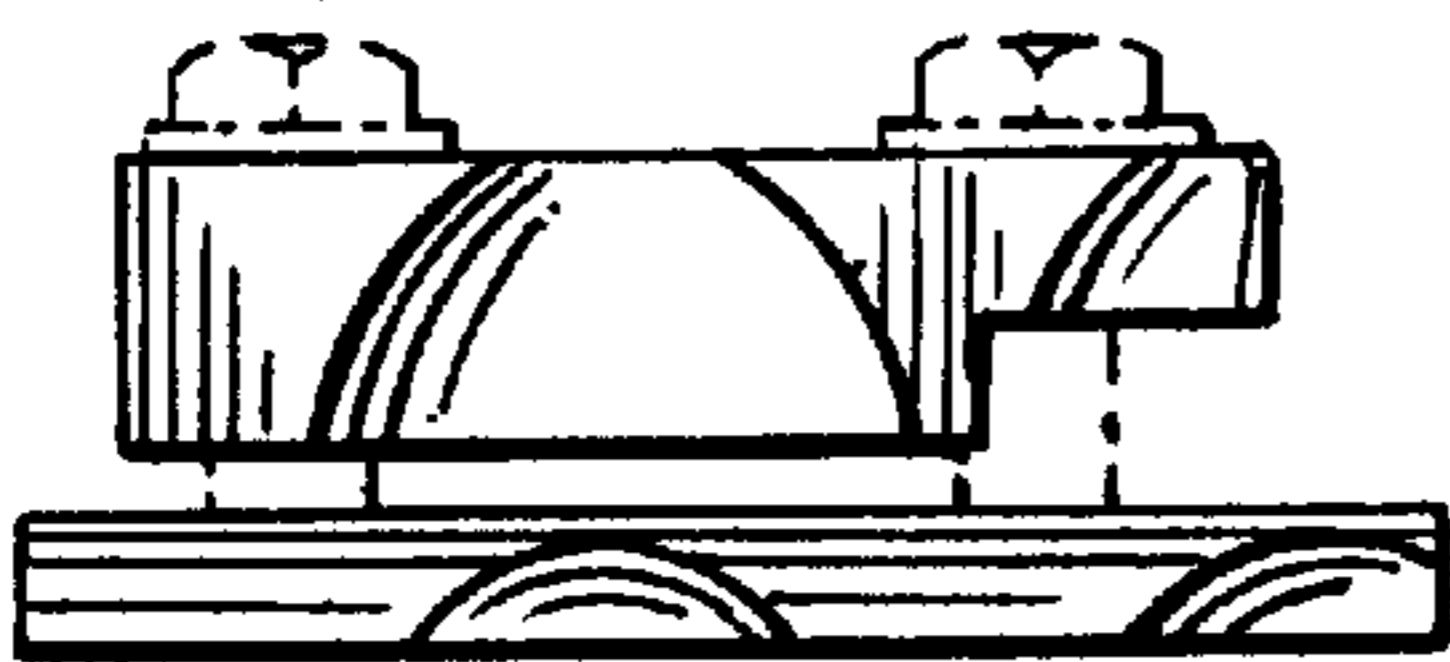

*FIG. 6*

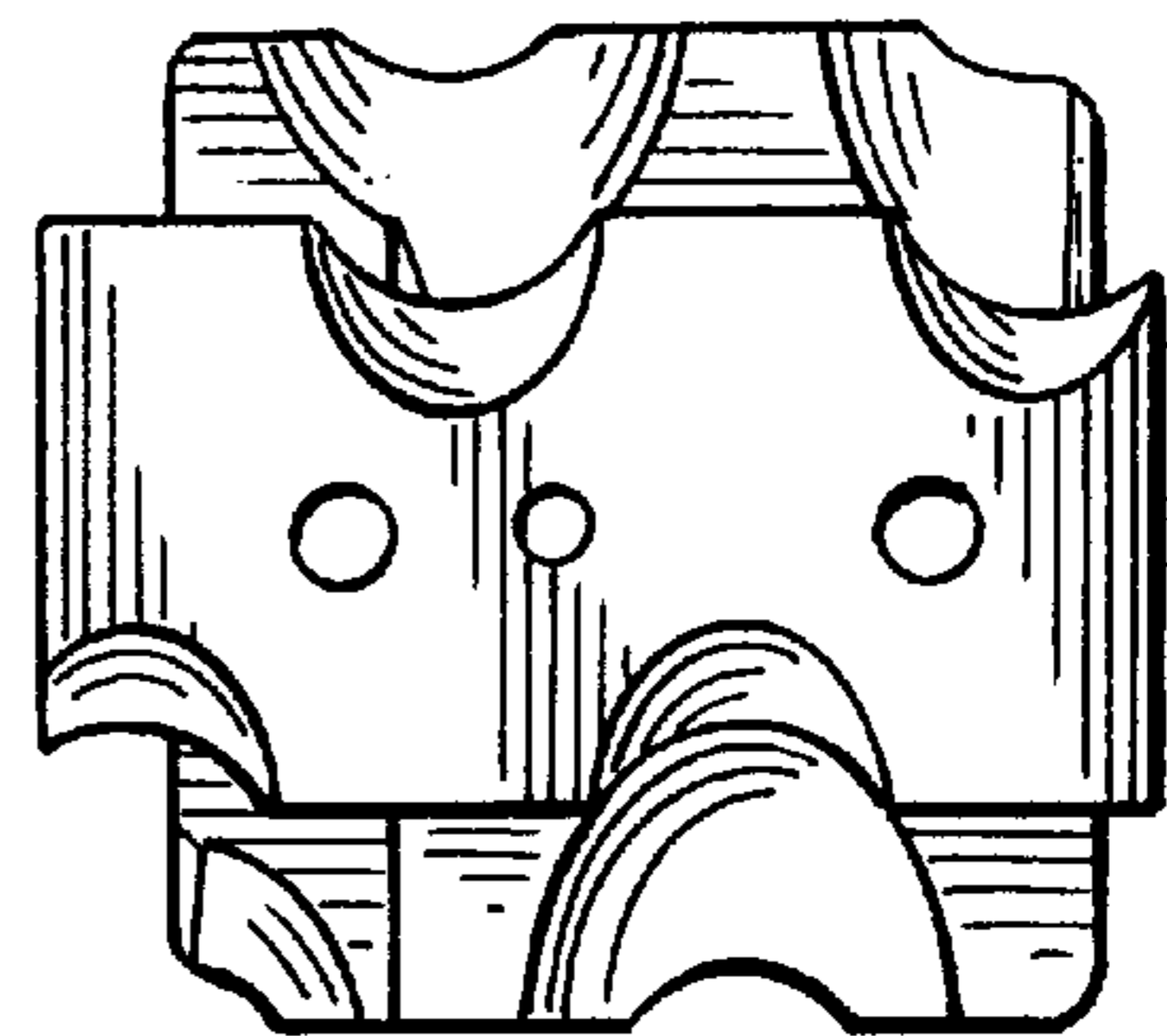

*FIG. 7*

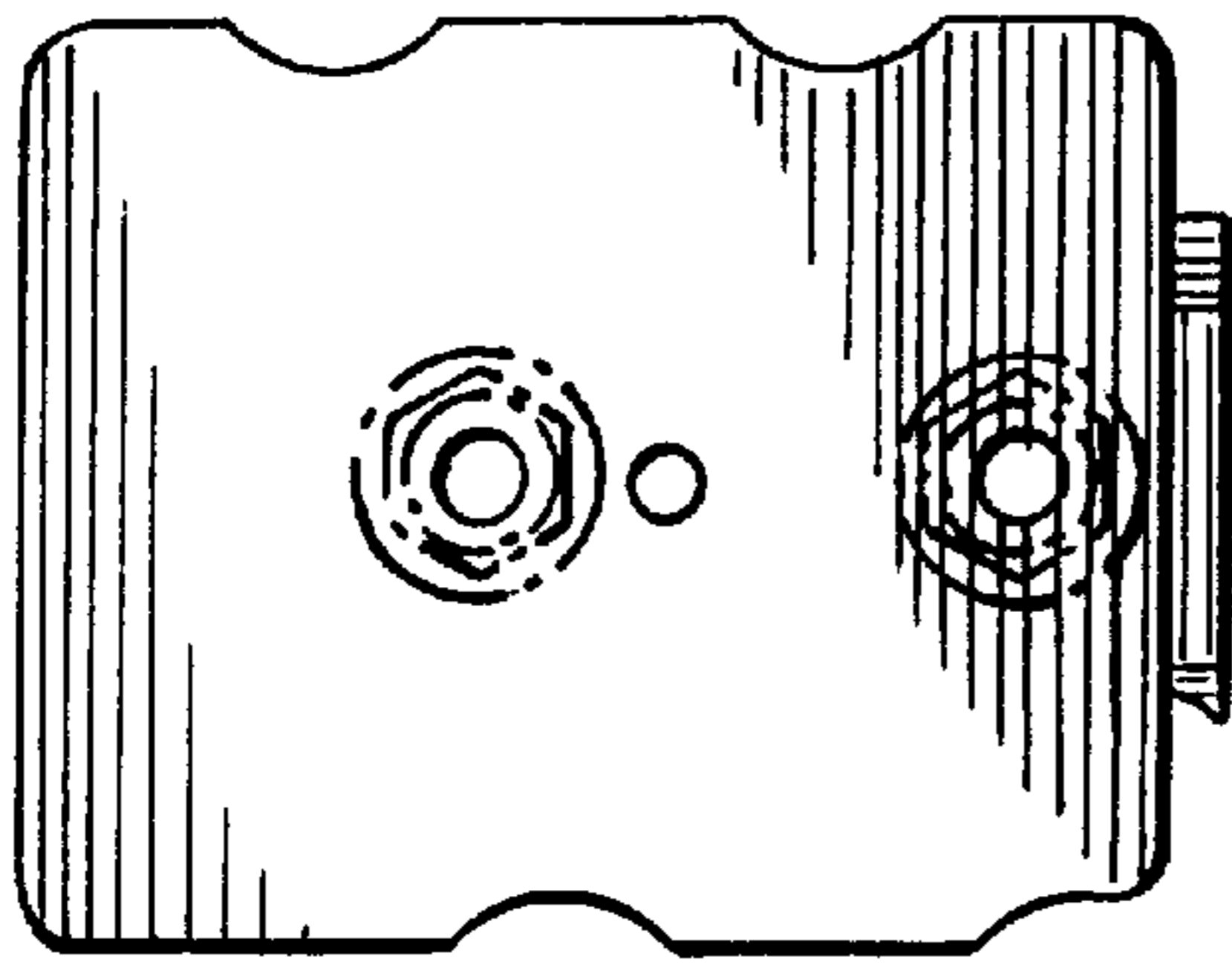

*FIG. 10*

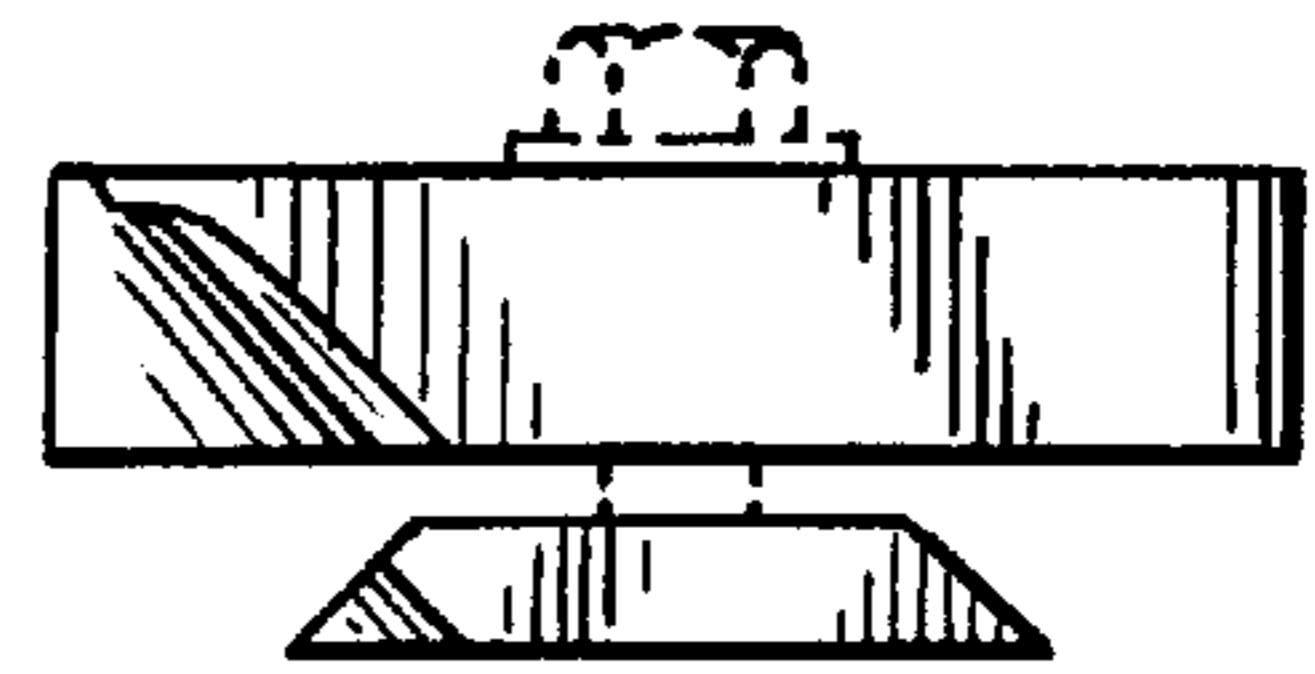

*FIG. 8*

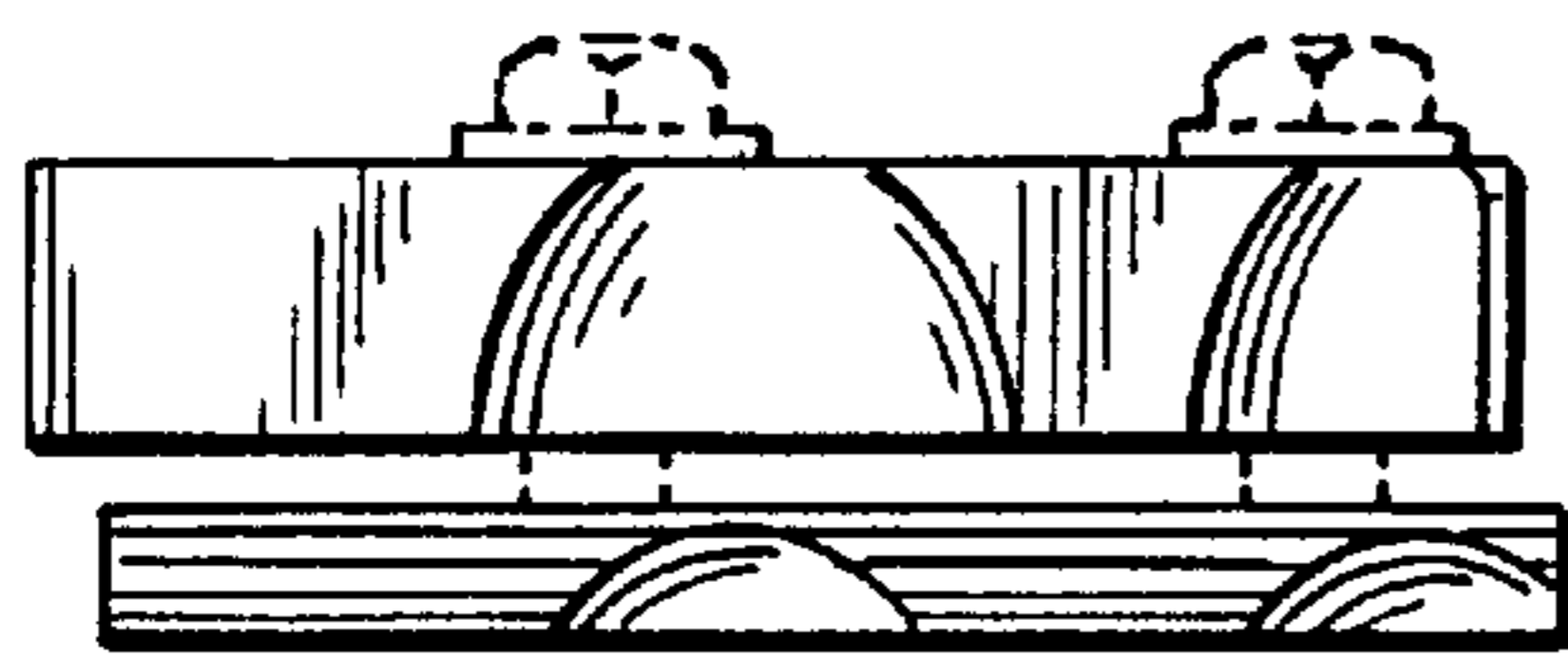

*FIG. 11*

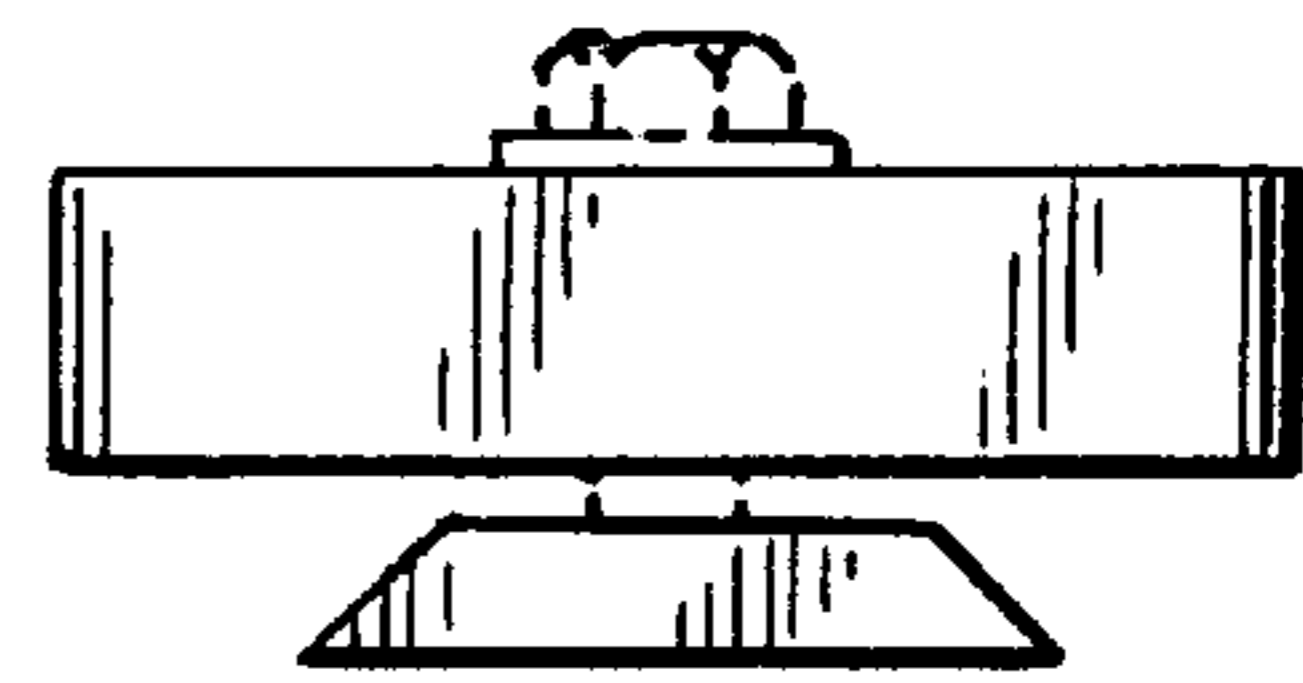

*FIG. 9*

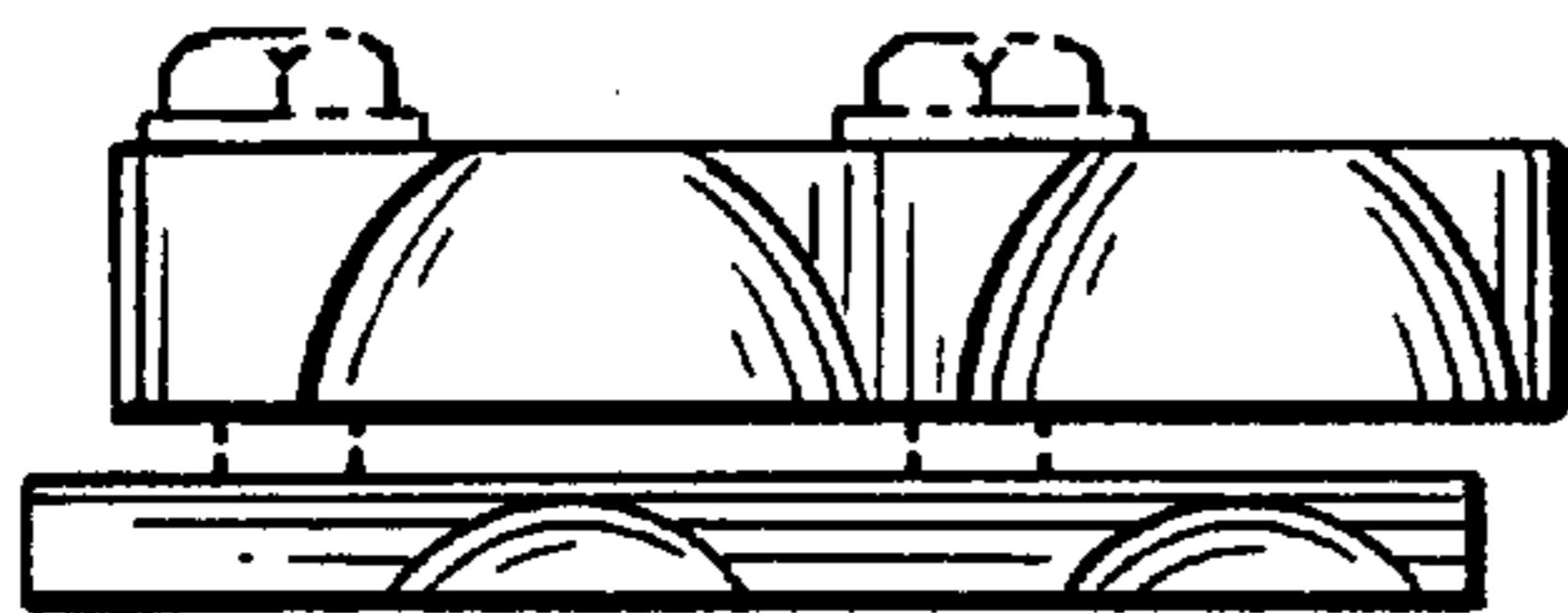

*FIG. 12*

