



US00D429216S

United States Patent [19] Hemphill

[11] Patent Number: **Des. 429,216**

[45] Date of Patent: **** Aug. 8, 2000**

[54] **MOTORCYCLE STARTER MOTOR**

Attorney, Agent, or Firm—Leonard Tachner

[76] Inventor: **Lewis Hemphill**, 20310 Fuero Dr.,
Walnut, Calif. 91789

[57] **CLAIM**

The ornamental design for a motorcycle starter motor, as shown and described.

[**] Term: **14 Years**

DESCRIPTION

[21] Appl. No.: **29/113,440**

FIG. 1 is a bottom view of a preferred embodiment of the present invention;

[22] Filed: **Nov. 4, 1999**

FIG. 2 is a top view of a preferred embodiment of the invention;

[51] **LOC (7) Cl.** **13-01**

[52] **U.S. Cl.** **D13/113; D12/114**

FIG. 3 is a right-side view of a preferred embodiment of the invention;

[58] **Field of Search** **D12/110, 114;**
D13/113; D15/1, 3, 5; 123/185.14, 179;
74/7 A, 7 C, 7 E; 310/83, 89; 180/219;
280/288.4; 290/48

FIG. 4 is an inverted left-side view of a preferred embodiment of the present invention;

[56] **References Cited**

U.S. PATENT DOCUMENTS

D. 347,619	6/1994	VanHorn et al.	D13/113
D. 408,010	4/1999	Sato et al.	D13/113
5,035,151	7/1991	Isozumi	74/7 A
5,045,737	9/1991	Yamauchi	310/89
6,006,617	12/1999	Pawlik	74/7 A

FIG. 5 is a front view of a preferred embodiment of the present invention;

FIG. 6 is a rear view of a preferred embodiment of the present invention;

FIG. 7 is a bottom view of a second embodiment of the present invention; and,

FIG. 8 is a rear view of a second embodiment of the present invention, the only difference being the changes in contour on the rear cover.

Primary Examiner—Alan P. Douglas

Assistant Examiner—Linda Brooks

1 Claim, 4 Drawing Sheets

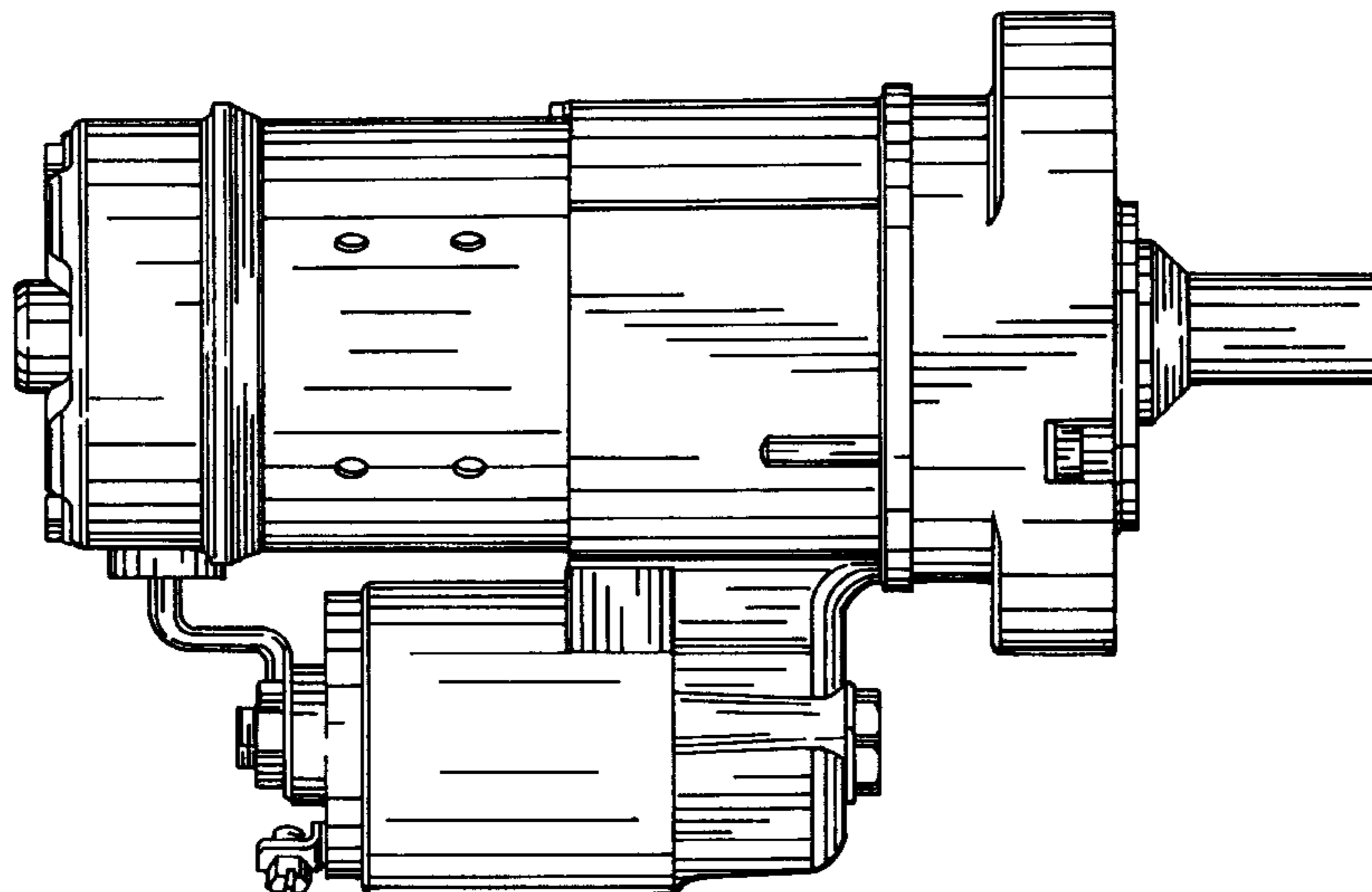
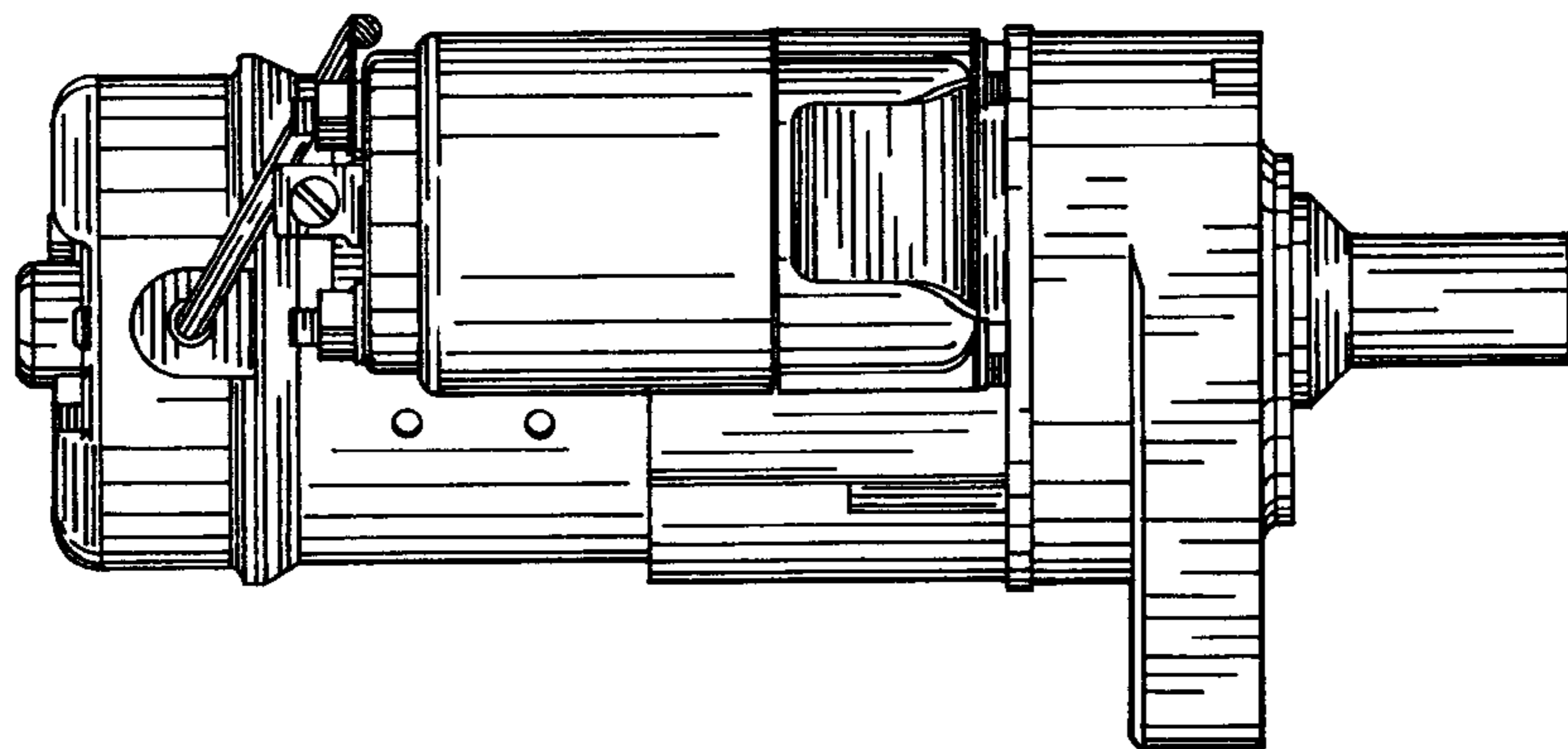

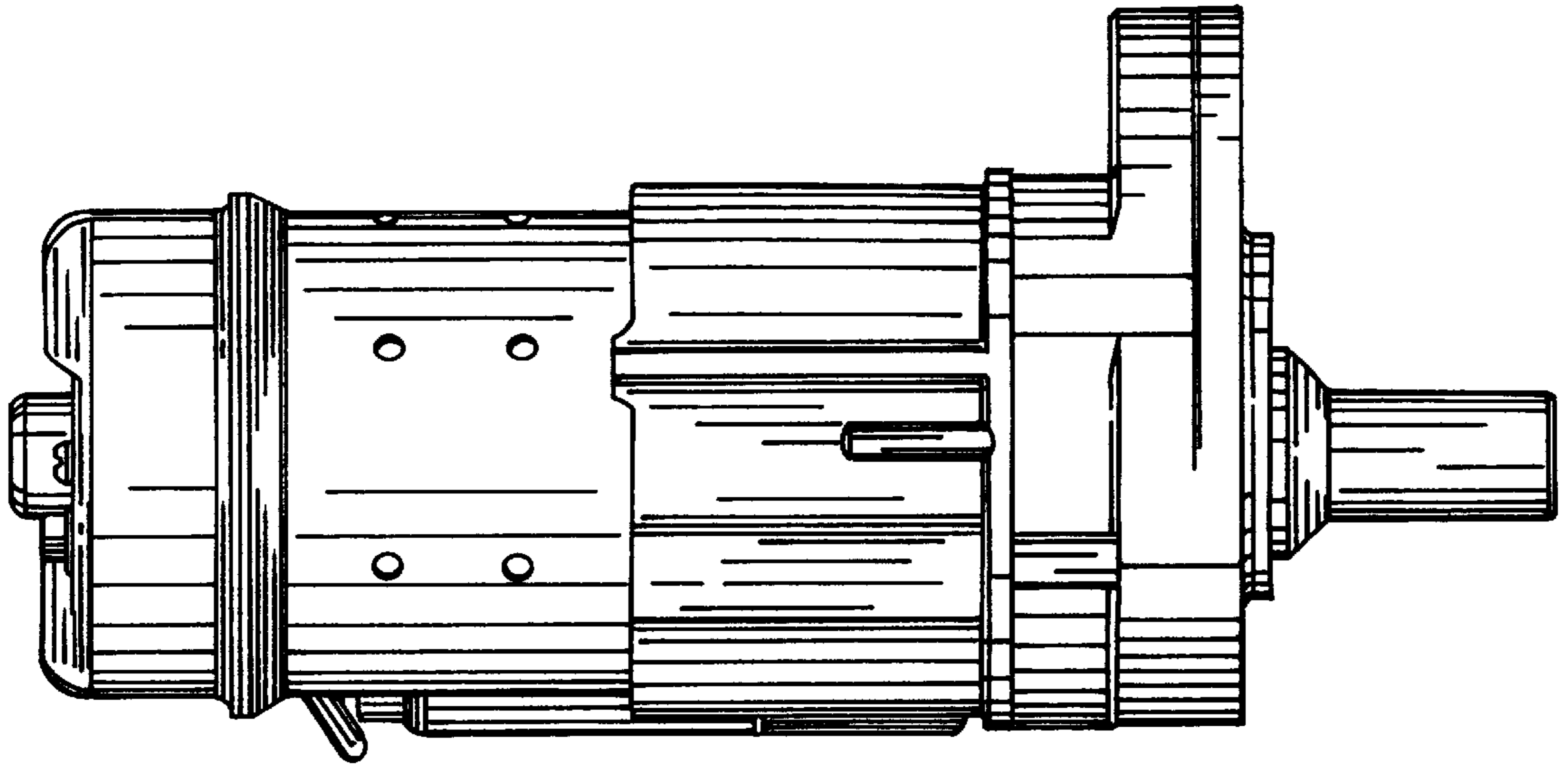

FIG. 1

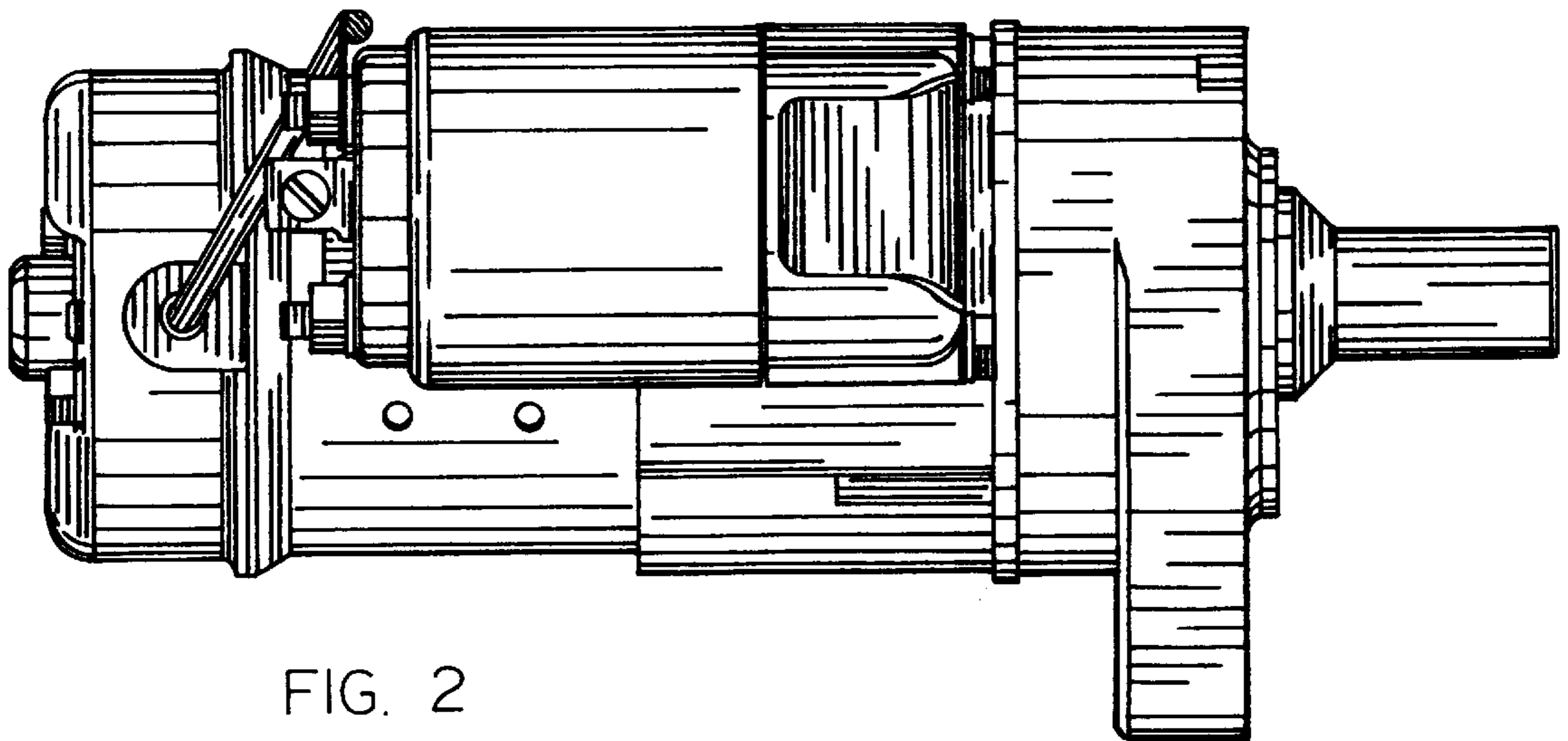

FIG. 2

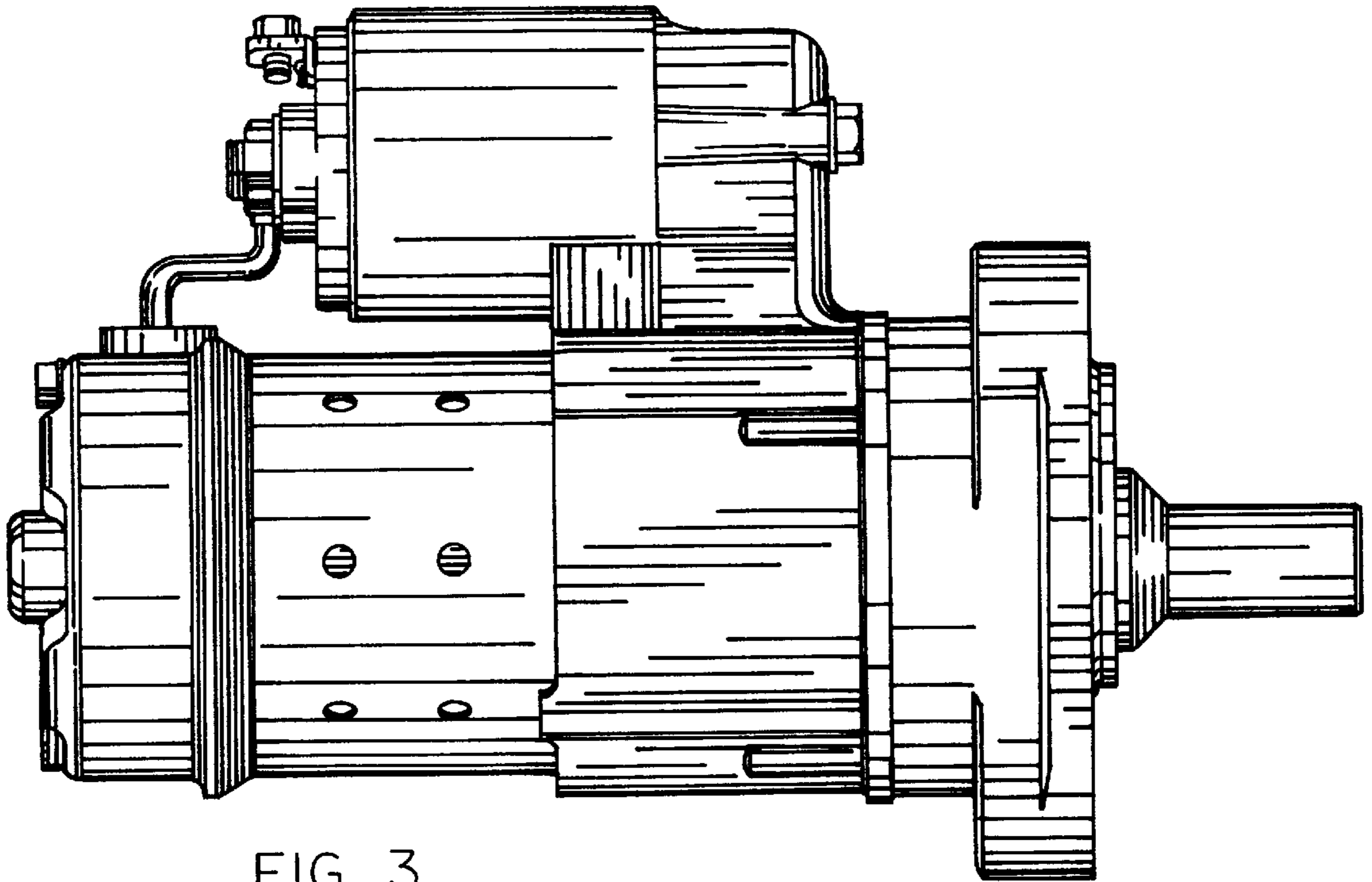

FIG. 3

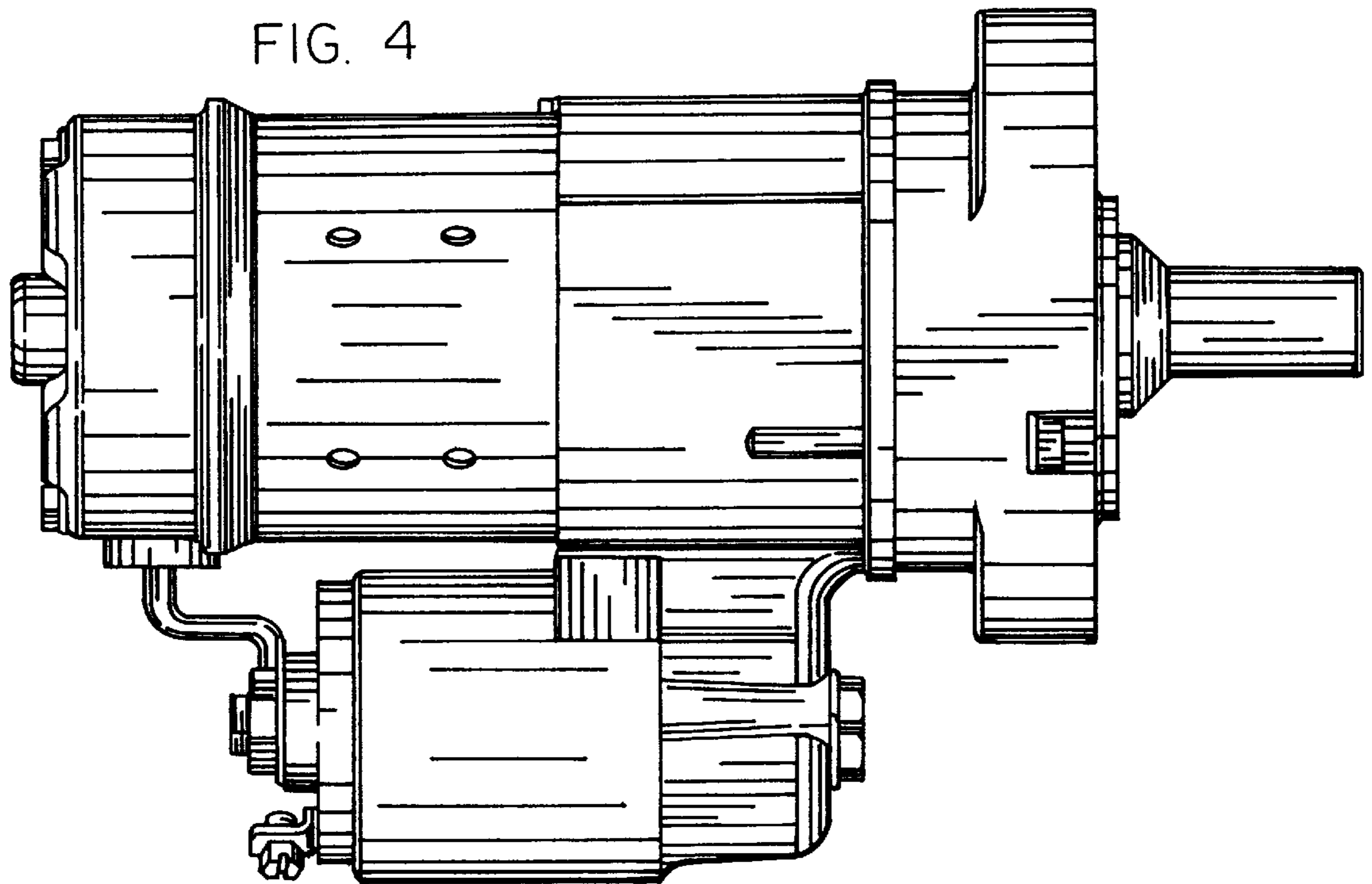

FIG. 4

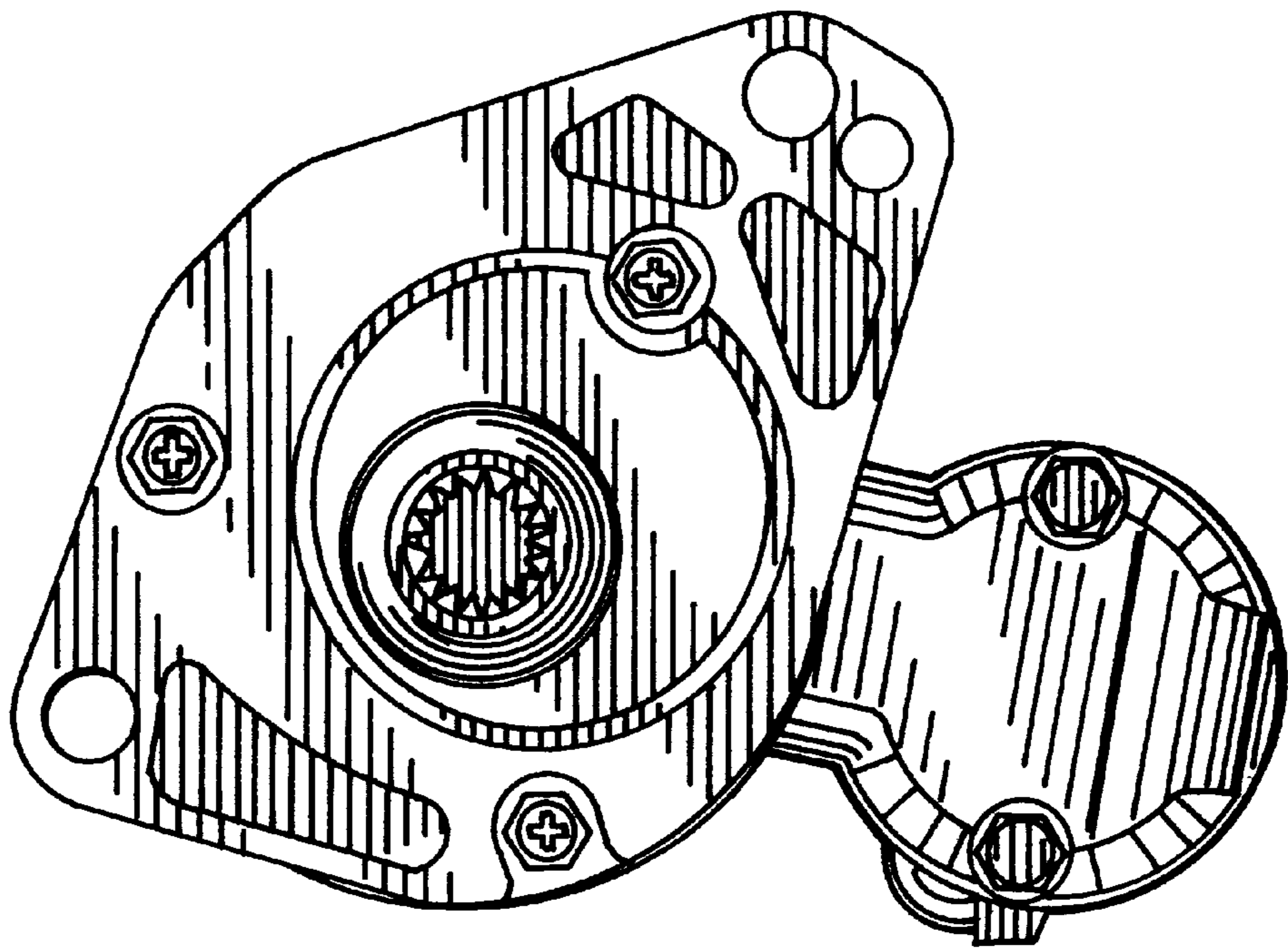

FIG. 5

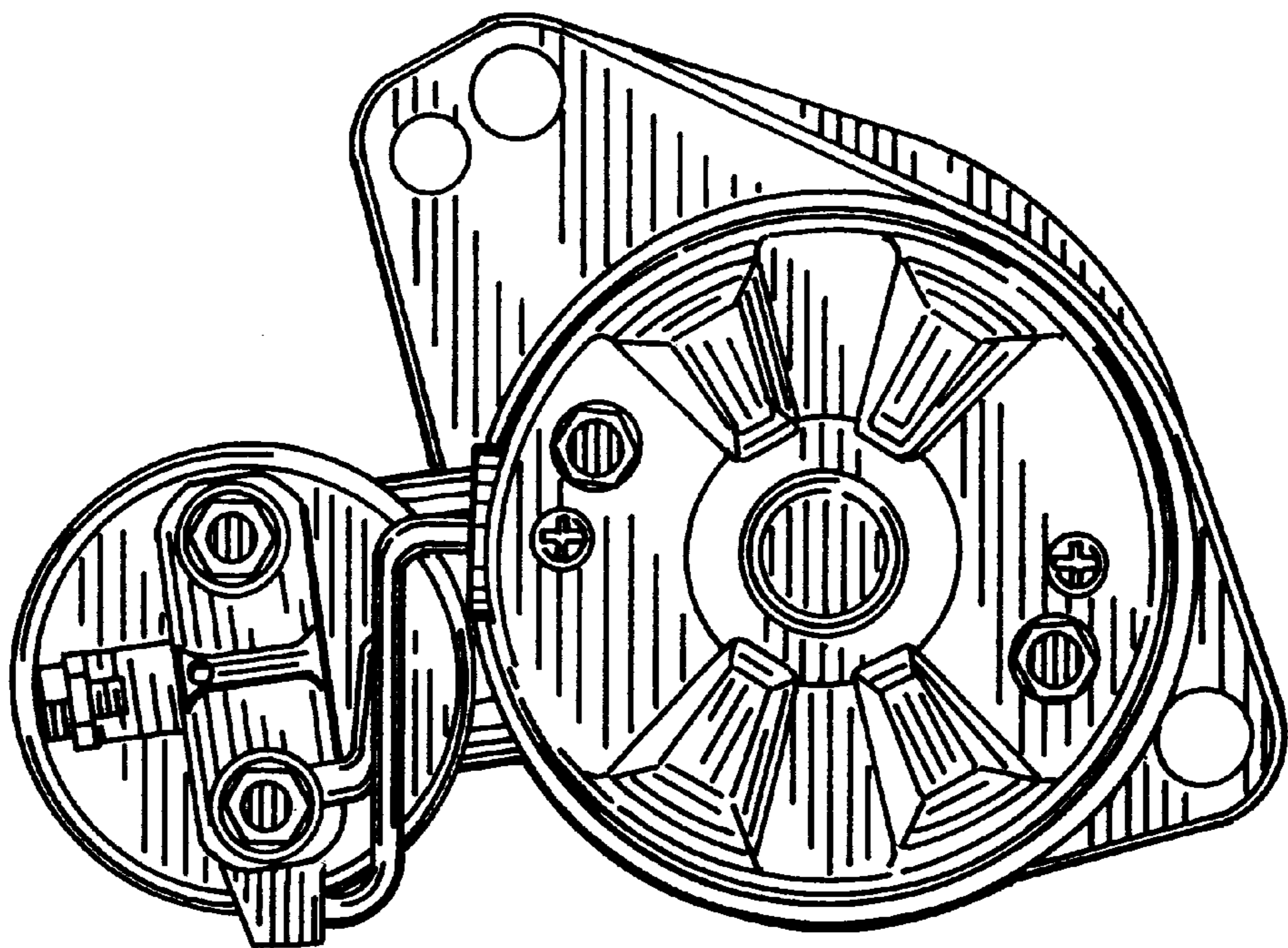

FIG. 6

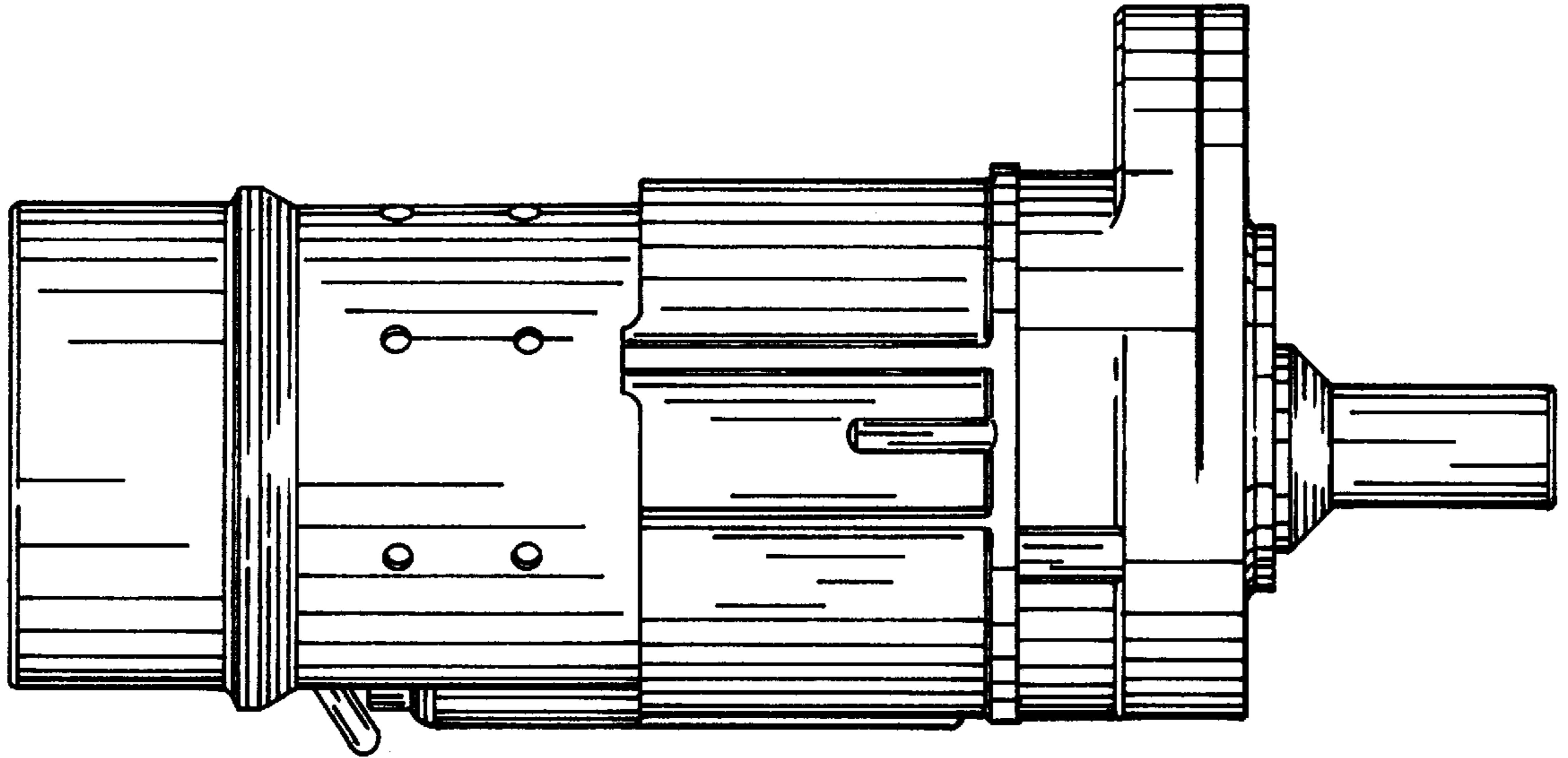

FIG. 7

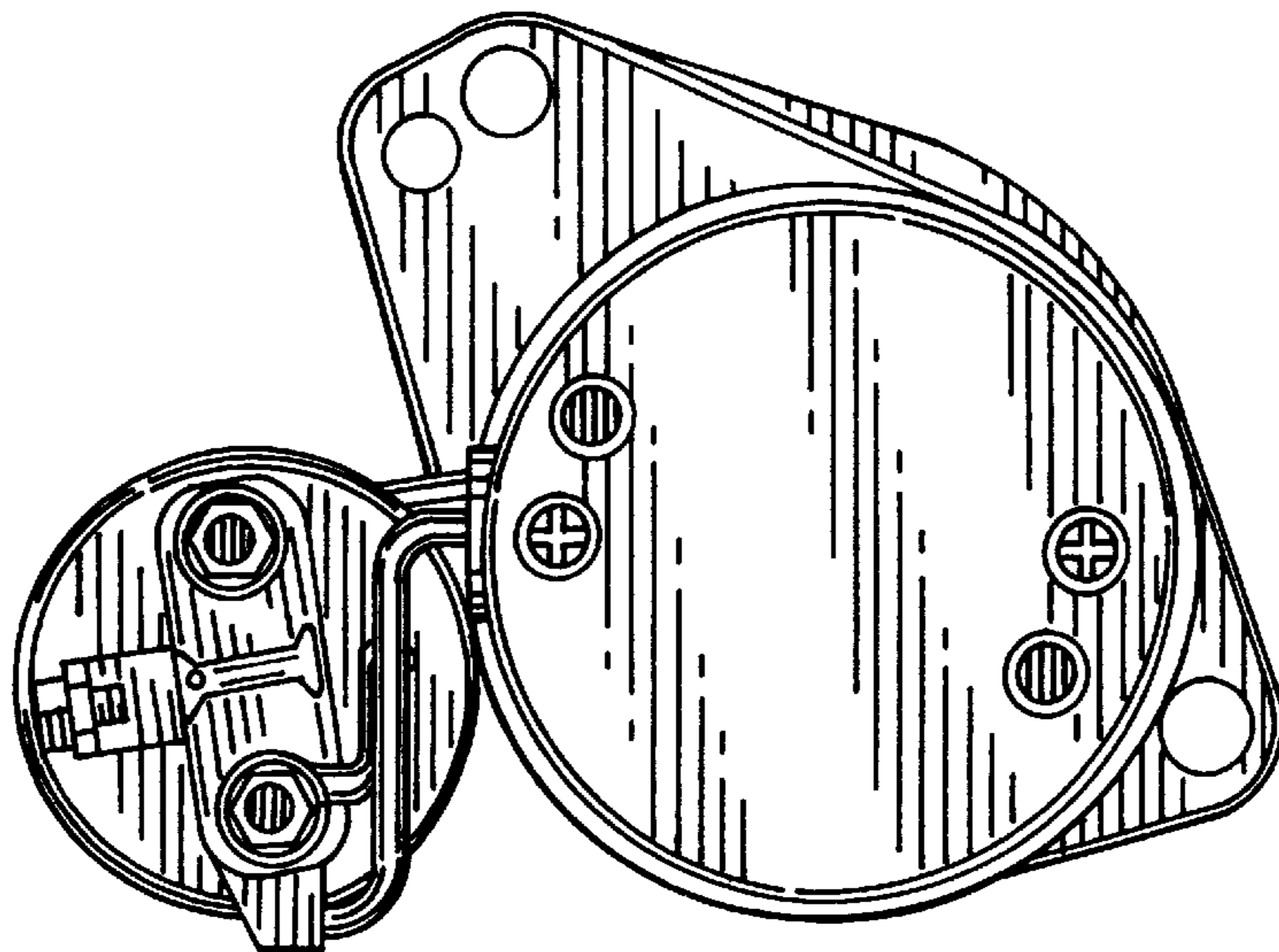

FIG. 8