



US00D429209S

United States Patent [19] Inchaurregui

[11] Patent Number: **Des. 429,209**

[45] Date of Patent: **** Aug. 8, 2000**

[54] **VEHICLE ACCESSORY CONTROL
CONSOLE**

[75] Inventor: **Rory D. Inchaurregui**, Loomis, Calif.

[73] Assignee: **Inch's Tooling & Machining**, Loomis, Calif.

[**] Term: **14 Years**

[21] Appl. No.: **29/113,951**

[22] Filed: **Nov. 15, 1999**

[51] **LOC (7) Cl.** **12-16**

[52] **U.S. Cl.** **D12/415**

[58] **Field of Search** D12/415, 400,
D12/416, 419-425; D14/137, 124, 217,
299, 157, 265; 296/37.1, 37.8-37.16; D3/313;
D6/473; 108/44; 224/400, 42.11, 539, 541-542,
548, 556, 926, 311, 540, 547

[56] **References Cited**

U.S. PATENT DOCUMENTS

D. 213,447	3/1969	Small	D14/265
D. 218,438	8/1970	Shook	D12/425
D. 219,965	2/1971	Boothe	D12/423
D. 222,357	10/1971	Locher	D12/415 X
D. 233,428	10/1974	Hestand	D12/415
D. 246,969	1/1978	Mease	D12/415
D. 248,636	7/1978	Stanley	D12/415
D. 279,329	6/1985	Dzak	D12/415

D. 279,426	7/1985	Dzak	D12/415
D. 311,450	10/1990	Burns	D12/425
D. 363,916	11/1995	Johnson	D12/415
D. 371,109	6/1996	Schlattl	D12/425
D. 382,534	8/1997	Green	D12/415
D. 419,519	1/2000	Whidbee	D12/415
2,934,391	4/1960	Bohnett	312/293.2
3,827,772	8/1974	Johnson	312/7.1

Primary Examiner—Stacia Cadmus
Attorney, Agent, or Firm—Heisler & Associates

[57] **CLAIM**

The ornamental design for a vehicle accessory control console, as shown and described.

DESCRIPTION

FIG. 1 is a perspective view of the vehicle accessory control console, showing my new design;
FIG. 2 is a right side view thereof, the left side view being a mirror image;
FIG. 3 is a top plan view thereof;
FIG. 4 is a bottom plan view thereof;
FIG. 5 is an auxiliary view of the console taken along lines 5—5 of FIG. 2;
FIG. 6 is a front elevation view thereof; and,
FIG. 7 is a rear elevation view thereof.
The broken lines in FIG. 1 are for purposes of illustration only and form no part of the claimed design.

1 Claim, 3 Drawing Sheets

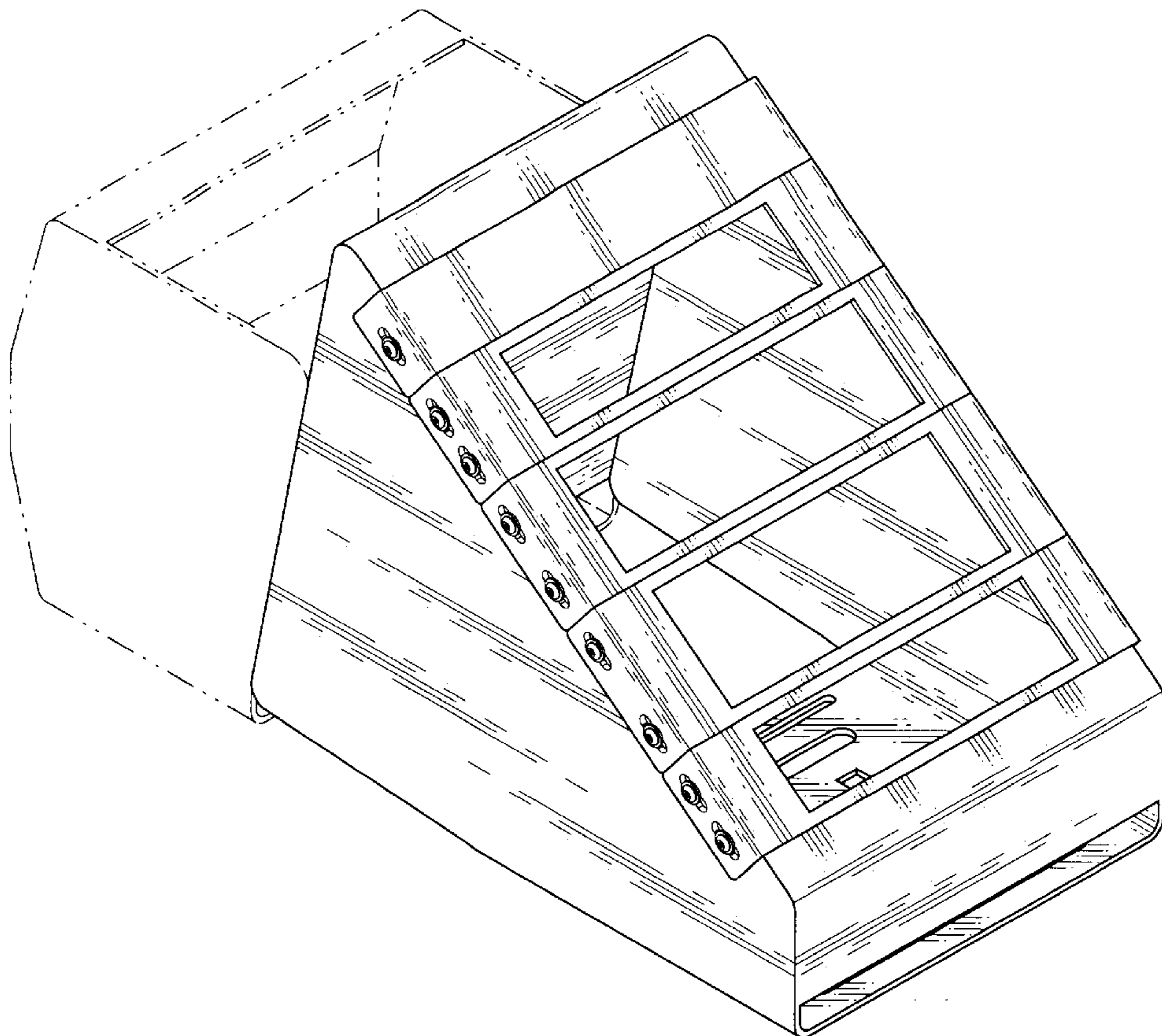

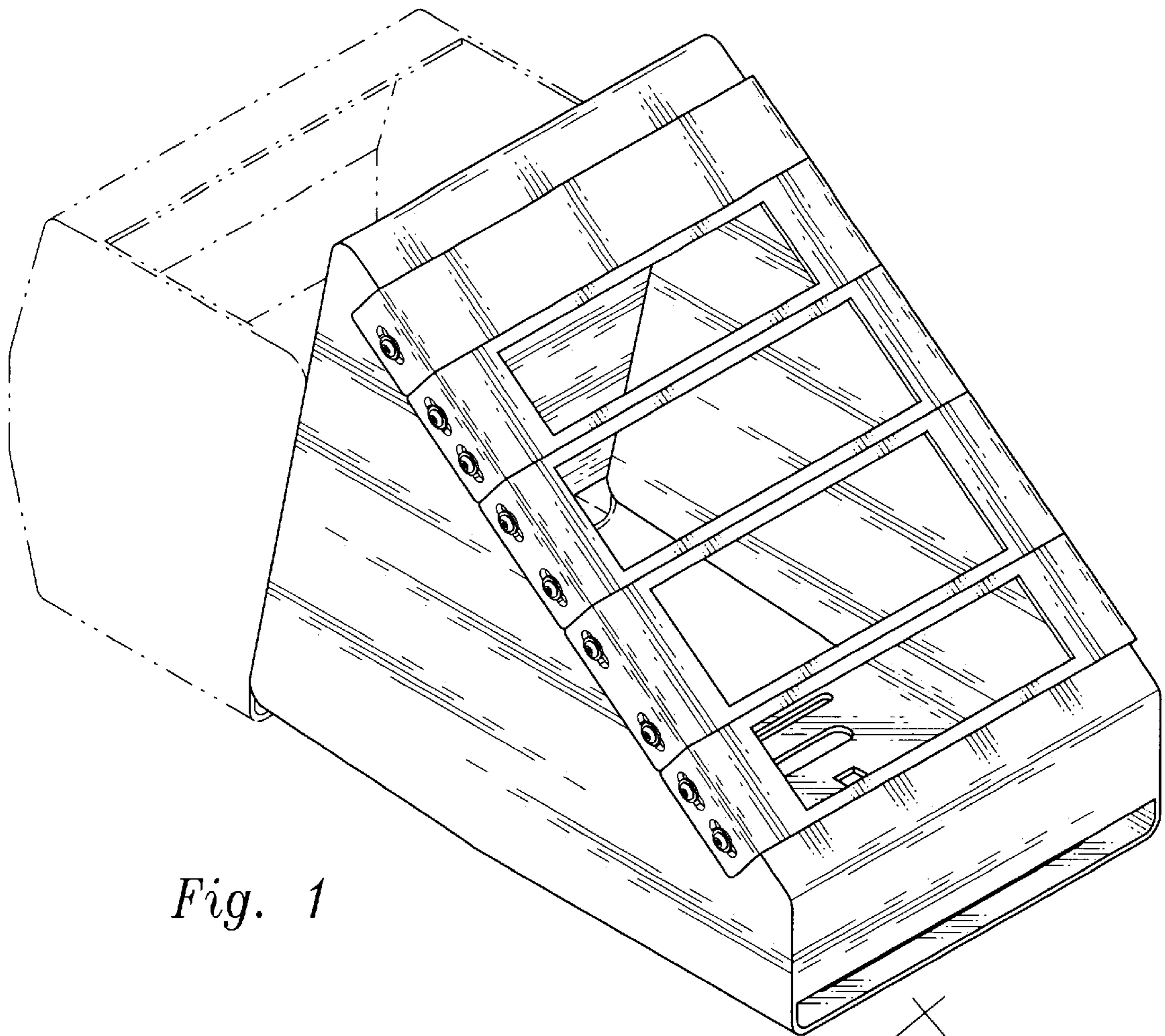

Fig. 1

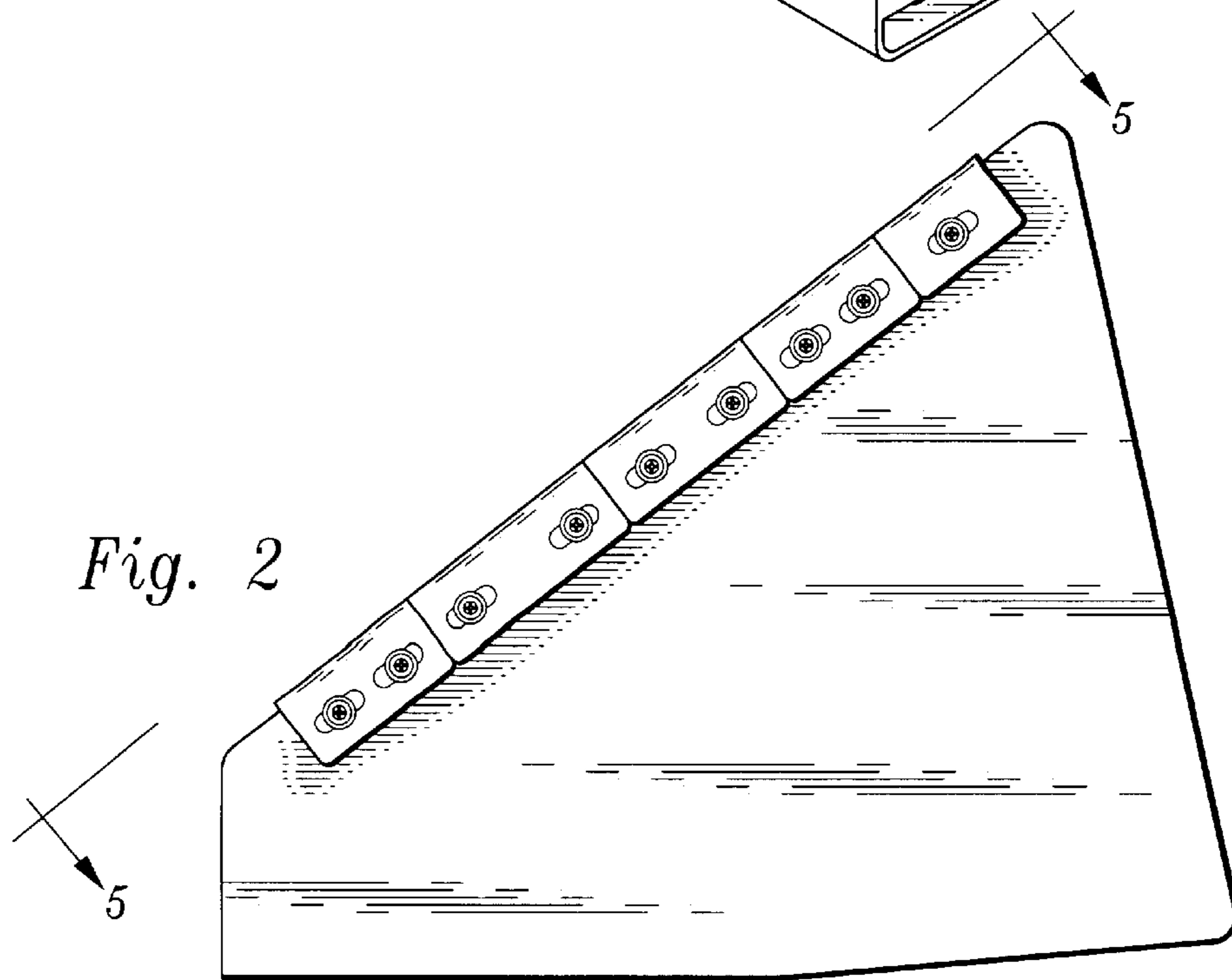

Fig. 2

Fig. 3

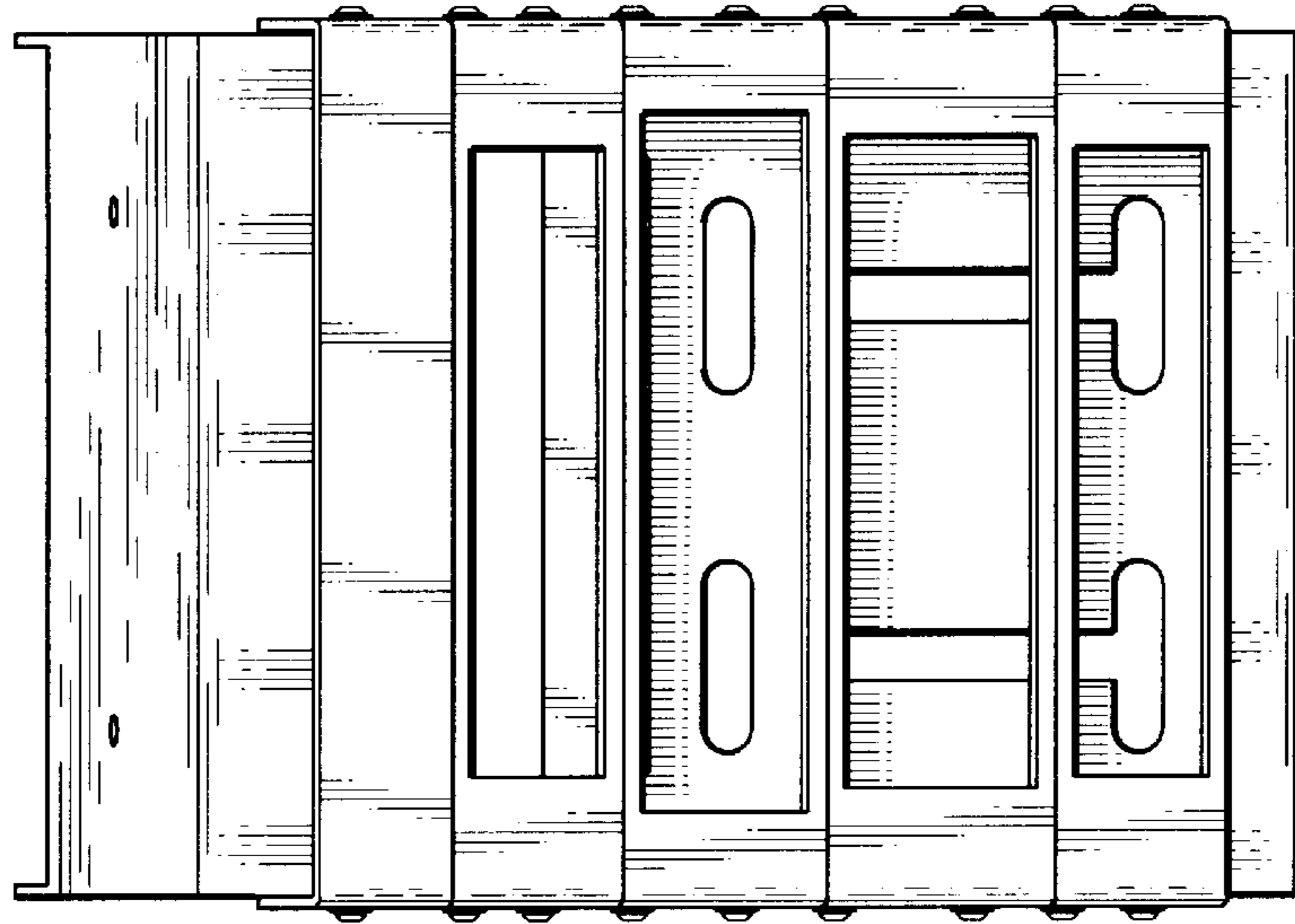

Fig. 4

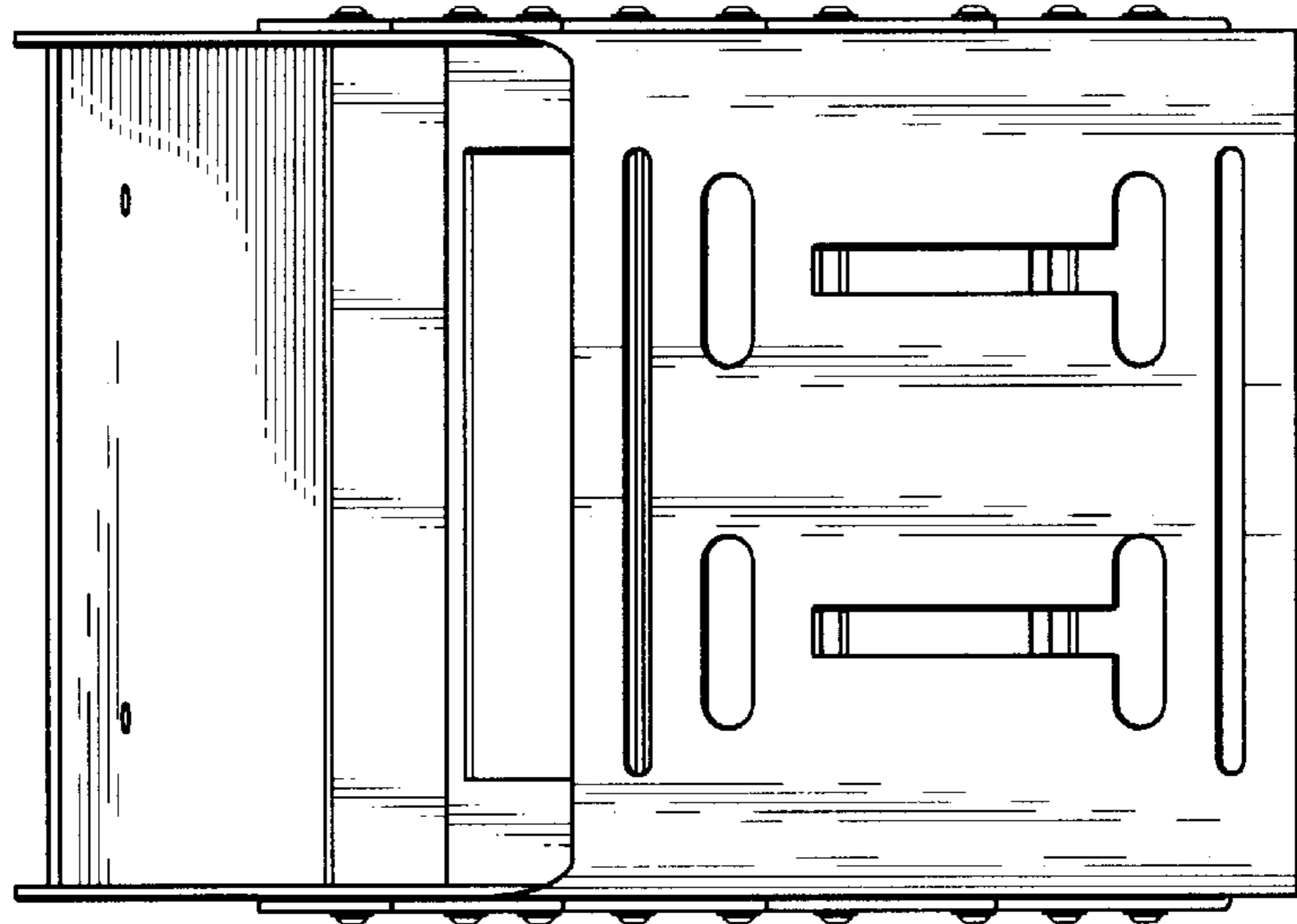
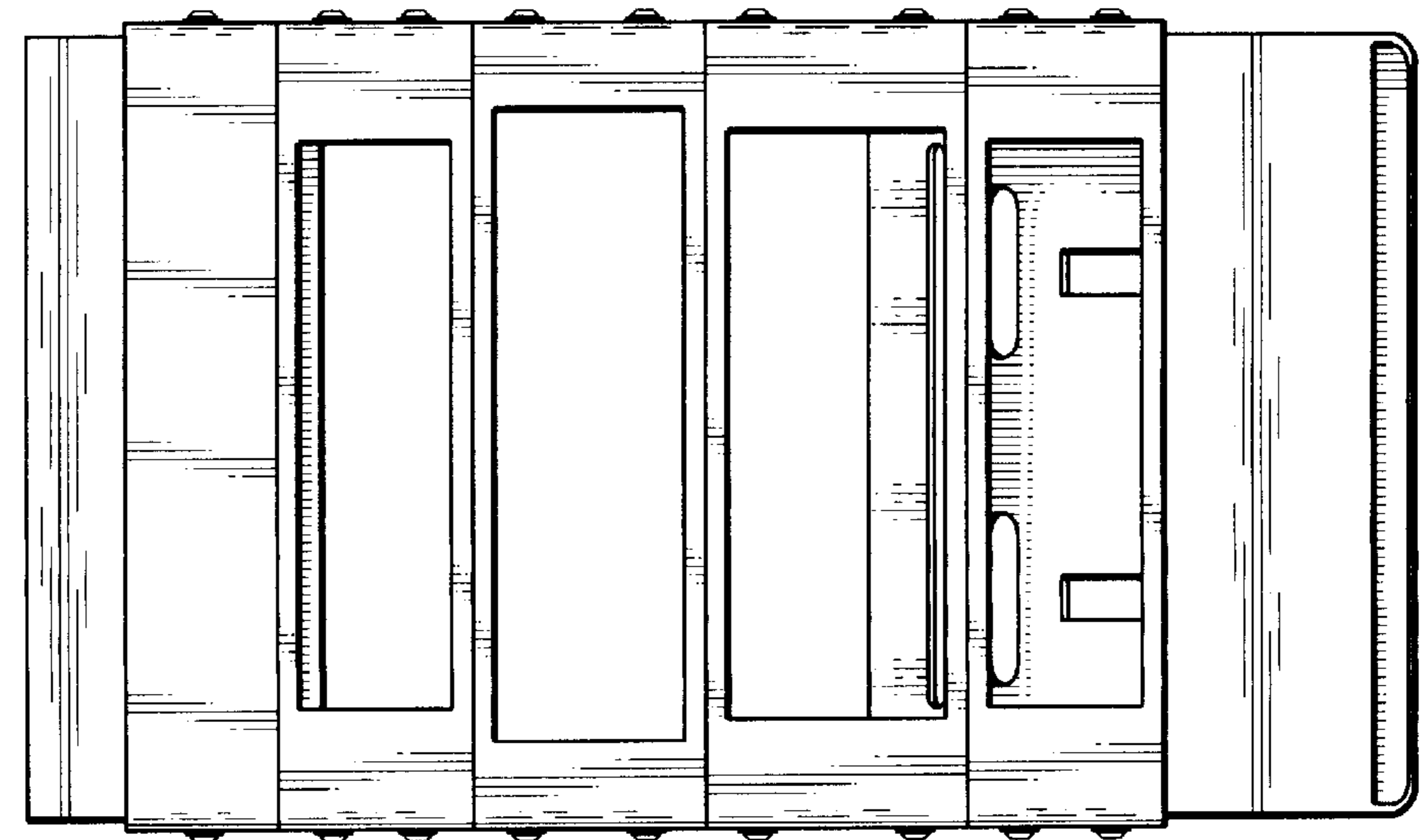

Fig. 5



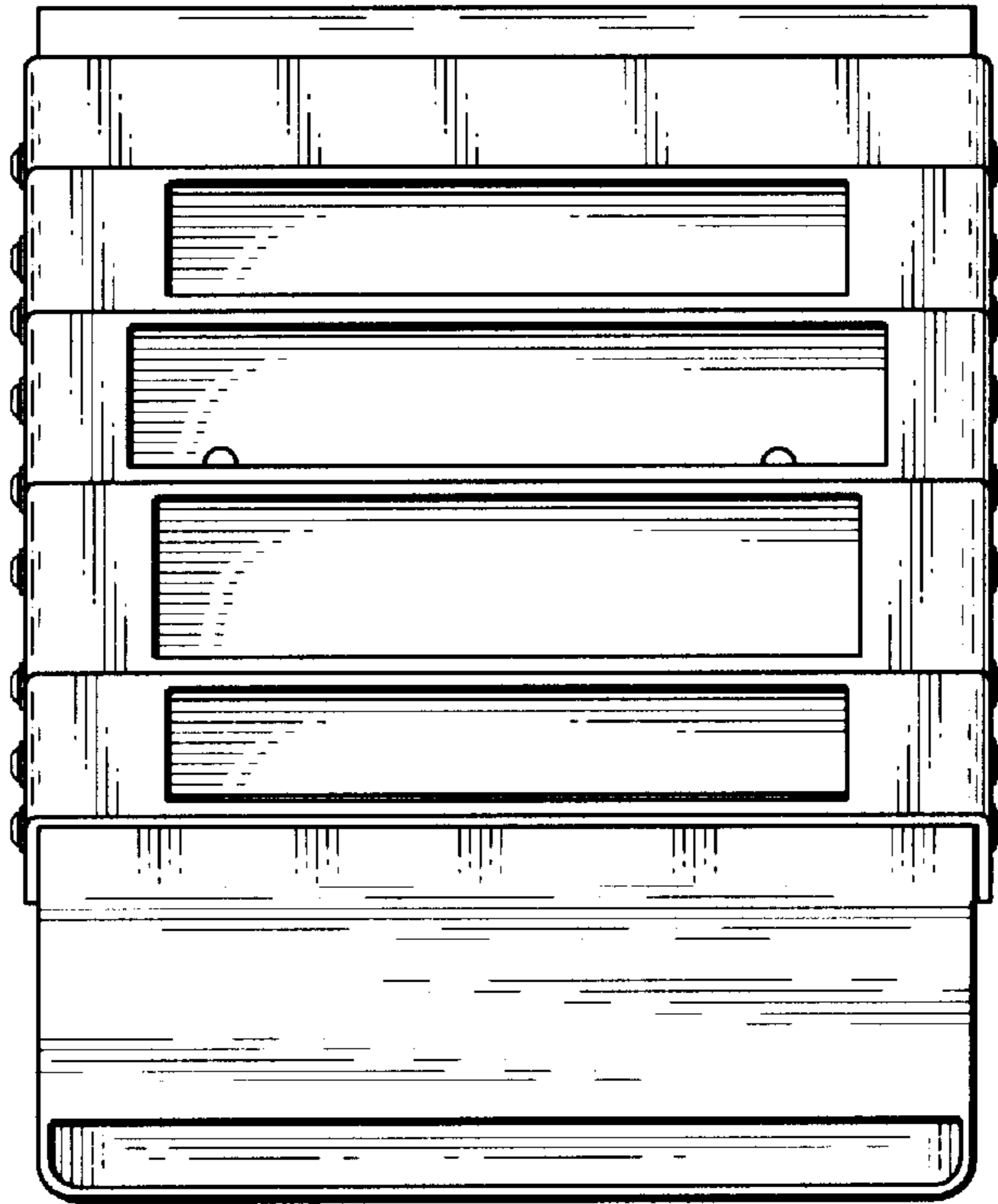

Fig. 6

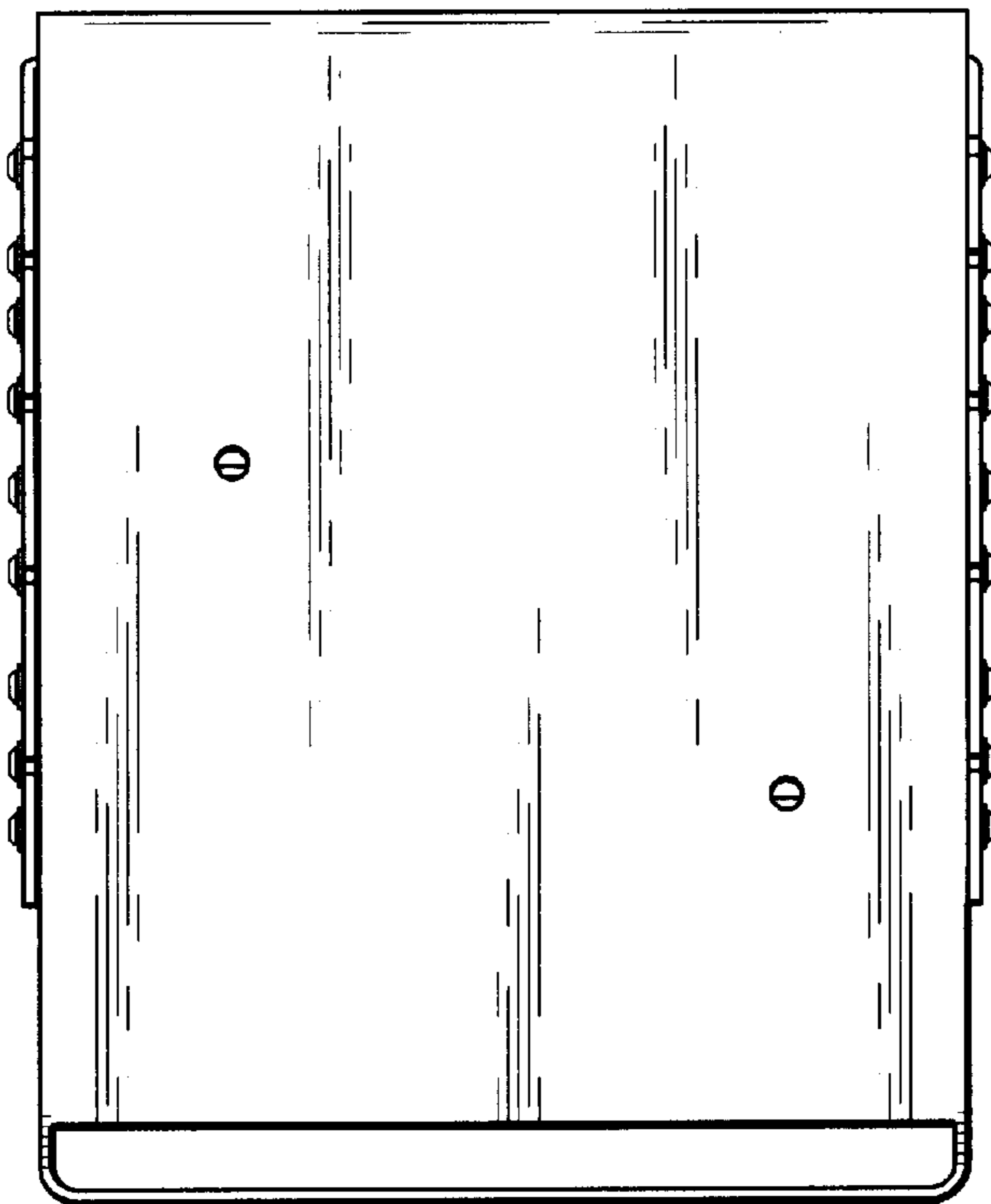

Fig. 7