



US00D429203S

United States Patent [19] Fink

[11] **Patent Number: Des. 429,203**

[45] **Date of Patent: ** Aug. 8, 2000**

[54] **VEHICLE PANEL**

[75] Inventor: **Michael L. Fink**, Steinegg-Neuhausen, Germany

[73] Assignee: **DaimlerChrysler AG**, Germany

[**] Term: **14 Years**

[21] Appl. No.: **29/108,677**

[22] Filed: **Aug. 3, 1999**

[30] **Foreign Application Priority Data**

Mar. 2, 1999 [DE] Germany 499 01 061

[51] **LOC (7) Cl.** **12-16**

[52] **U.S. Cl.** **D12/195**

[58] **Field of Search** D12/190, 195,
D12/192, 400; 296/191, 187, 180.1, 193,
196-197, 70

[56] **References Cited**

U.S. PATENT DOCUMENTS

D. 289,891 5/1987 Bielby D12/190

D. 329,632 9/1992 Masters D12/195 X
D. 333,118 2/1993 Stauffer D12/190
D. 386,458 11/1997 Smith D12/190
D. 399,465 10/1998 Saleen D12/195 X

Primary Examiner—Doris V. Coles
Assistant Examiner—Stacia Cadmus
Attorney, Agent, or Firm—Evenson, McKeown, Edwards & Lenahan, P.L.L.C.

[57] **CLAIM**

The ornamental design for a vehicle panel, as shown and described.

DESCRIPTION

FIG. 1 is a perspective view of a vehicle panel according to my novel design;

FIG. 2 is an enlarged front view of the vehicle panel according to my novel design; and,

FIG. 3 is an enlarged top view of the vehicle panel according to my novel design.

The dash lines shown depict environment and are not part of my claimed design.

1 Claim, 2 Drawing Sheets

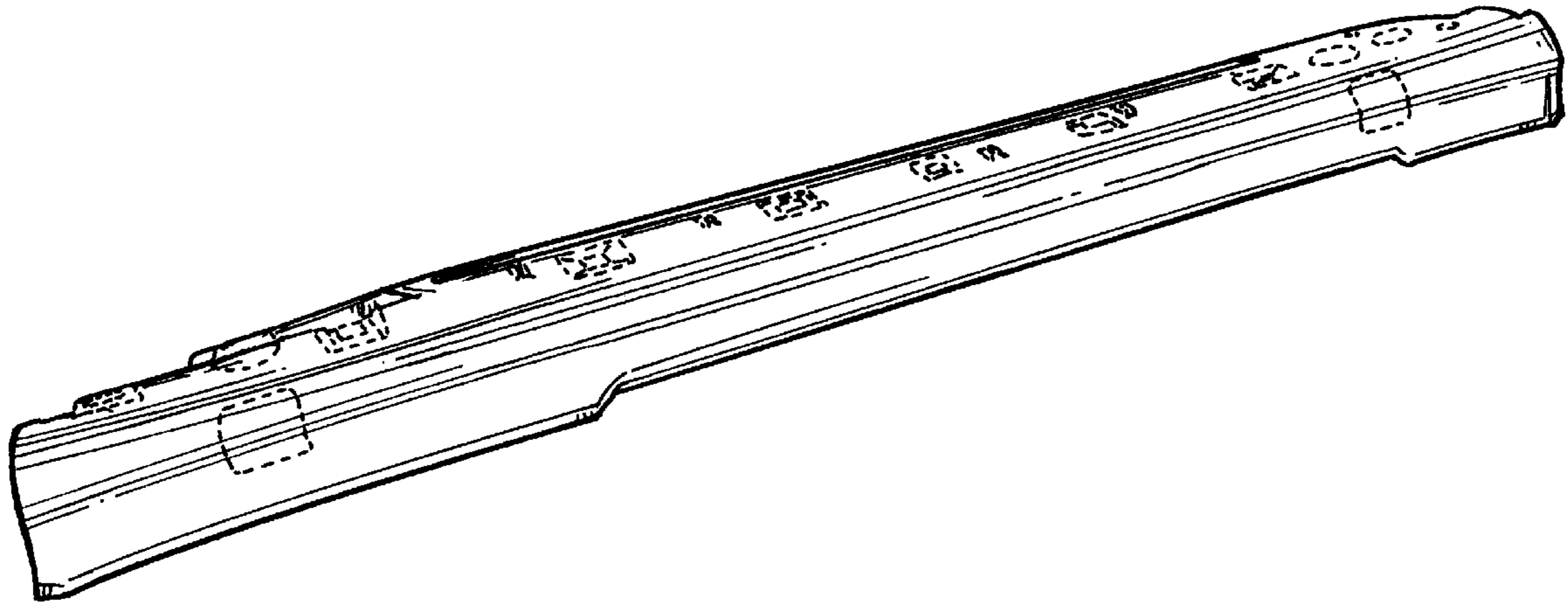

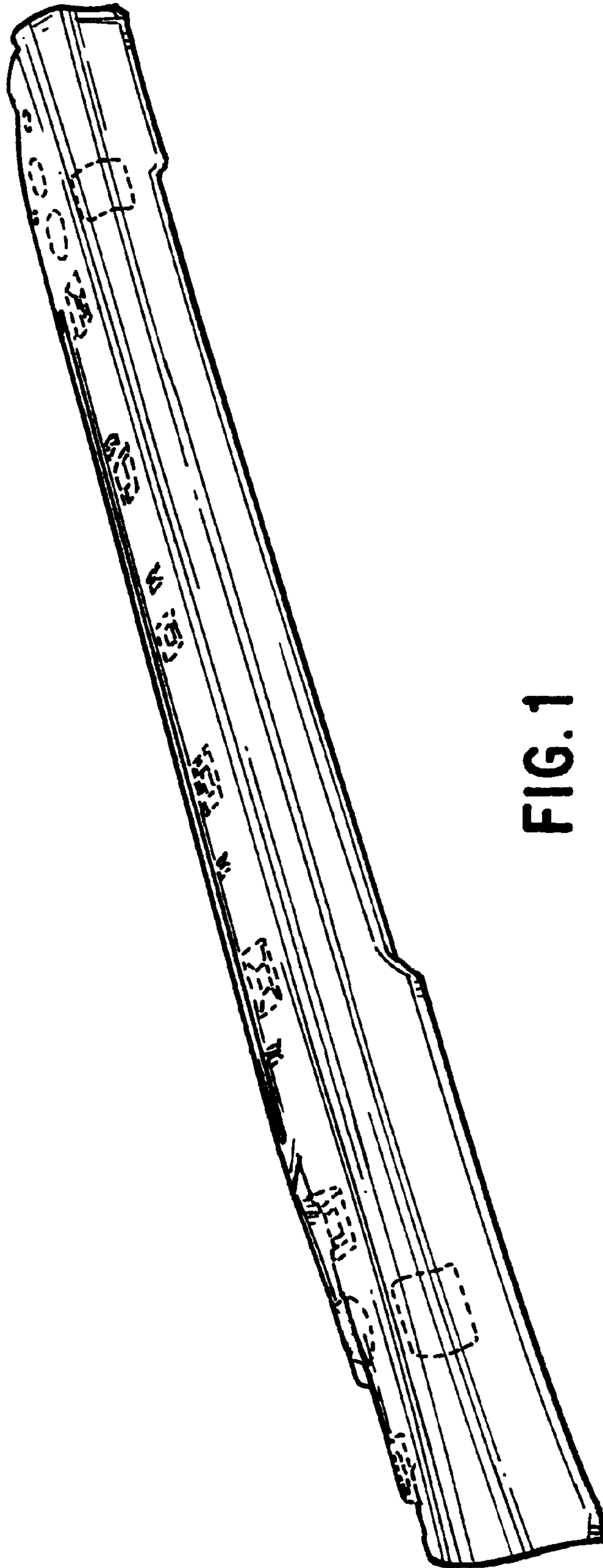

FIG. 1

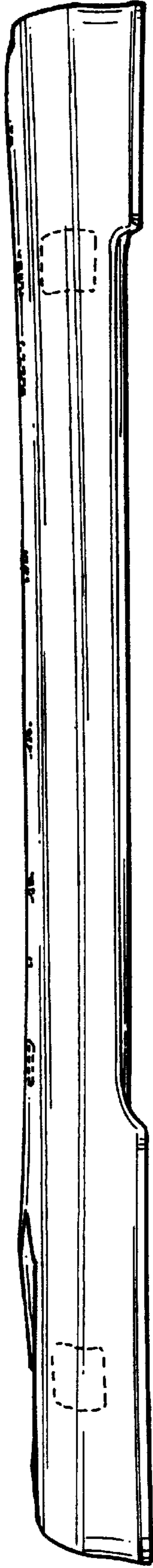

FIG. 2

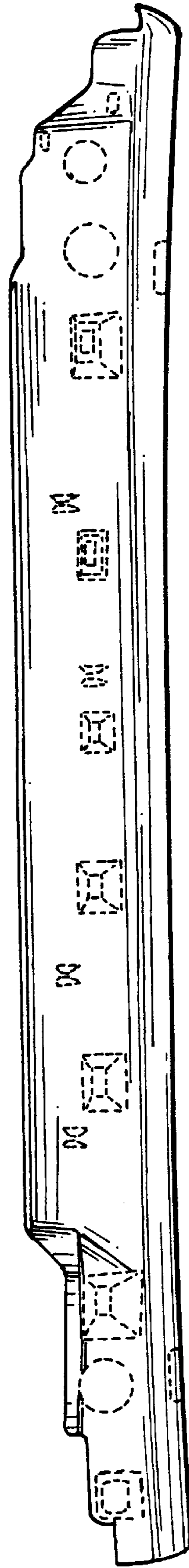

FIG. 3