



US00D429176S

United States Patent [19]
Dicks, Sr.

[11] **Patent Number: Des. 429,176**
[45] **Date of Patent: ** Aug. 8, 2000**

[54] **DRIVEWAY MARKER**

DESCRIPTION

[75] Inventor: **Cyril Dicks, Sr.**, Ancaster, Canada
[73] Assignee: **Top Tape & Label Ltd.**, Ancaster, Canada
[**] Term: **14 Years**
[21] Appl. No.: **29/091,109**
[22] Filed: **Jul. 23, 1998**
[30] **Foreign Application Priority Data**
Jun. 9, 1998 [CA] Canada 98-1411
[51] **LOC (7) Cl.** **10-05**
[52] **U.S. Cl.** **D10/109; D20/41**
[58] **Field of Search** D20/10, 11, 40,
D20/41, 42; 40/541, 588, 591, 592, 624;
362/811, 812

[56] **References Cited**

U.S. PATENT DOCUMENTS

D. 399,260 10/1998 Thimote D10/109
D. 399,262 10/1998 Turner D10/109
D. 399,776 10/1998 Hernandez et al. D10/109
D. 400,593 11/1998 Schmidt D10/109

Primary Examiner—Marcus A. Jackson
Attorney, Agent, or Firm—Ingrid Schmidt

[57] **CLAIM**

The ornamental design for a driveway marker, as shown and described.

FIG. 1 is a right side elevation view of a driveway marker, showing a first embodiment of my new design, the left side elevation view being a mirror image thereof;
FIG. 2 is a front elevation view thereof;
FIG. 3 is a back elevation view thereof;
FIG. 4 is a top plan view thereof;
FIG. 5 is a front elevation view of a second embodiment thereof;
FIG. 6 is a front elevation view of a third embodiment thereof;
FIG. 7 is a back elevation view of a fourth embodiment thereof;
FIG. 8 is a front elevation view of a fifth embodiment thereof;
FIG. 9 is a front elevation view of a sixth embodiment thereof;
FIG. 10 is a back elevation view of the embodiment shown in FIG. 9;
FIG. 11 is a top plan view of the embodiment shown in FIG. 9; and
FIG. 12 is a right side elevation view of the embodiment shown in FIG. 9, the left side elevation being a mirror image thereof.
The portions of the drawings shown in broken lines in FIGS. 1 to 7 indicate surrounding structure comprising a supporting post, which does not form part of the design. The characteristic feature of the design resides in the honeycomb shape of the driveway marker.

1 Claim, 3 Drawing Sheets

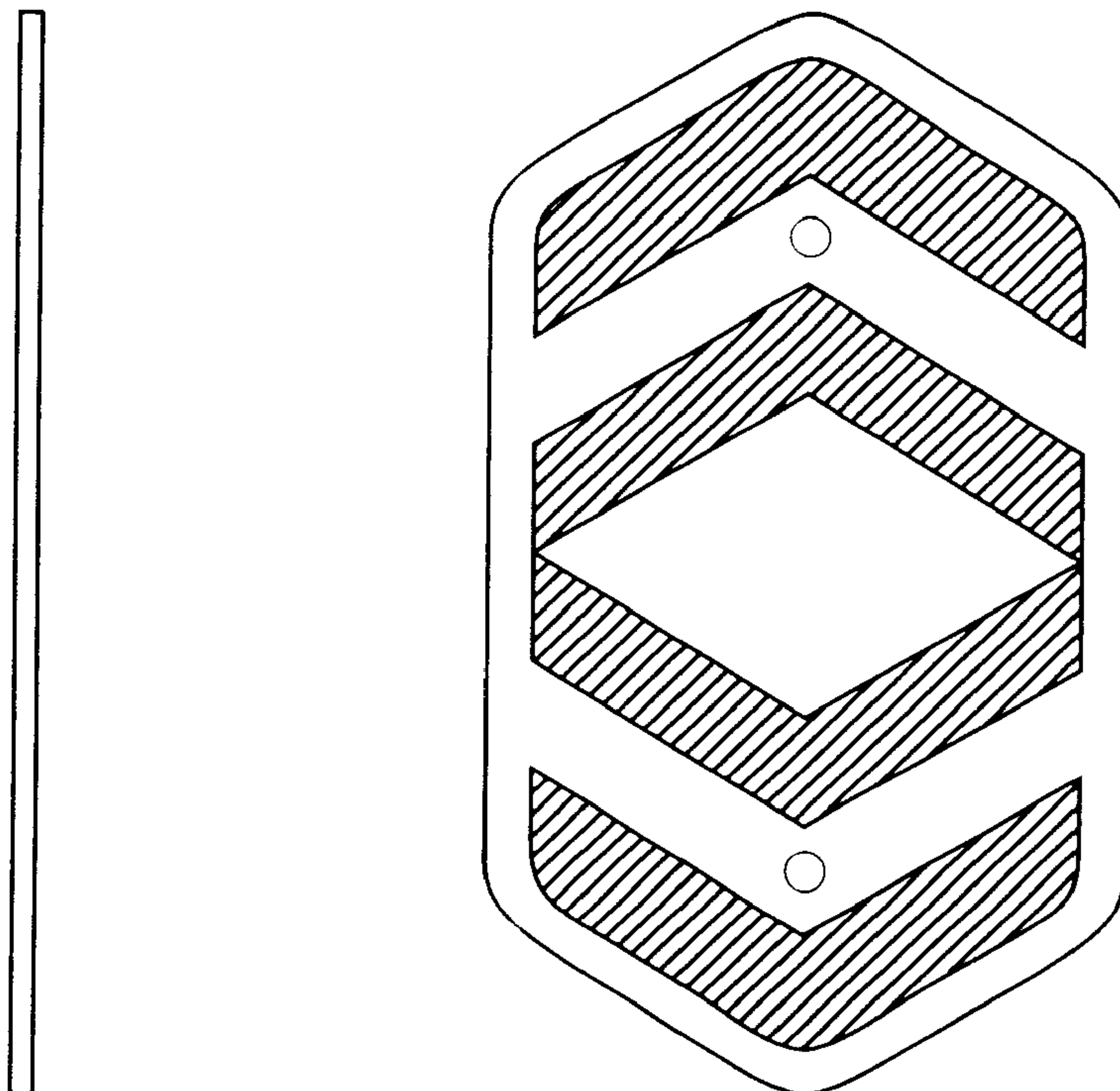

Fig. 1



Fig. 2

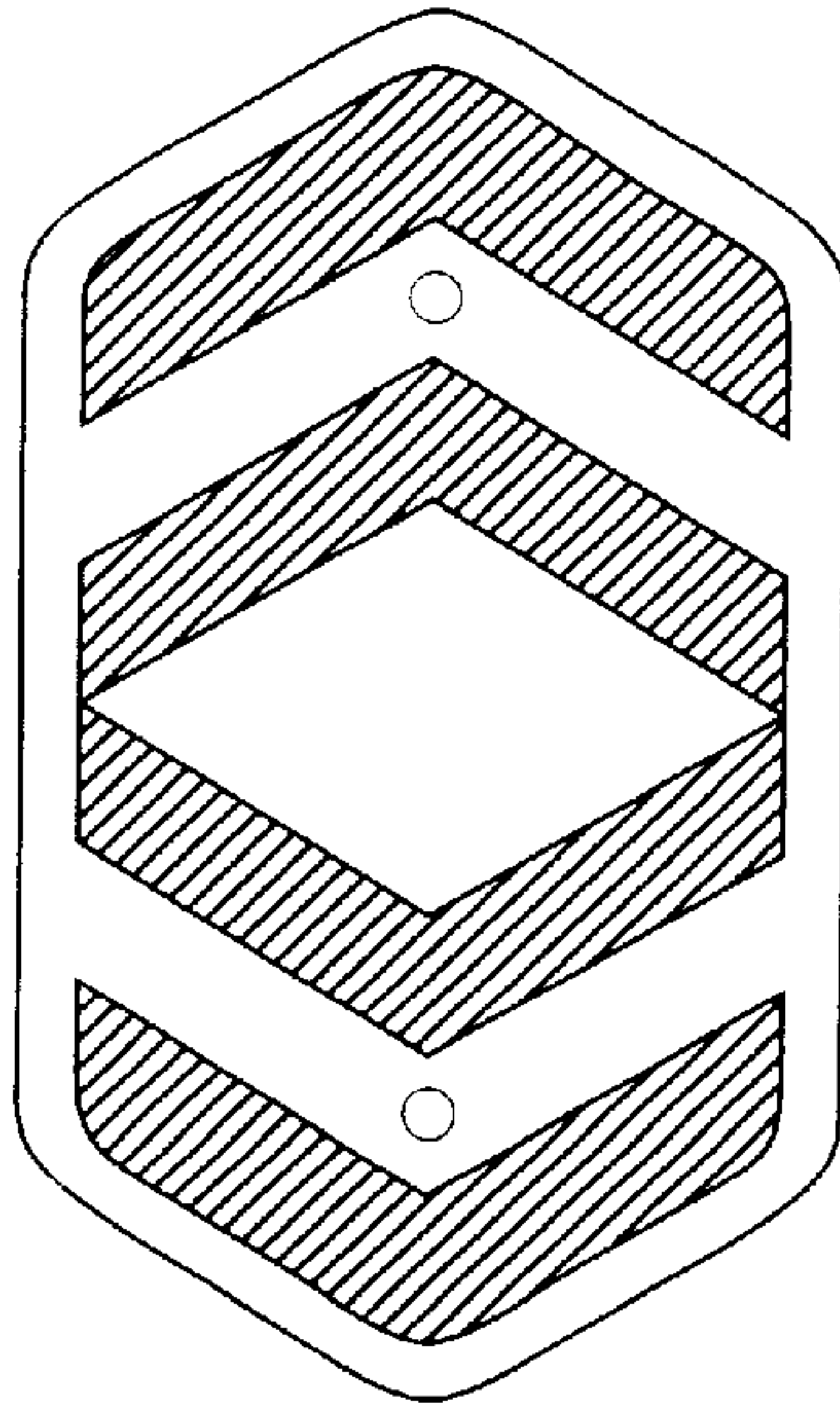

Fig. 3

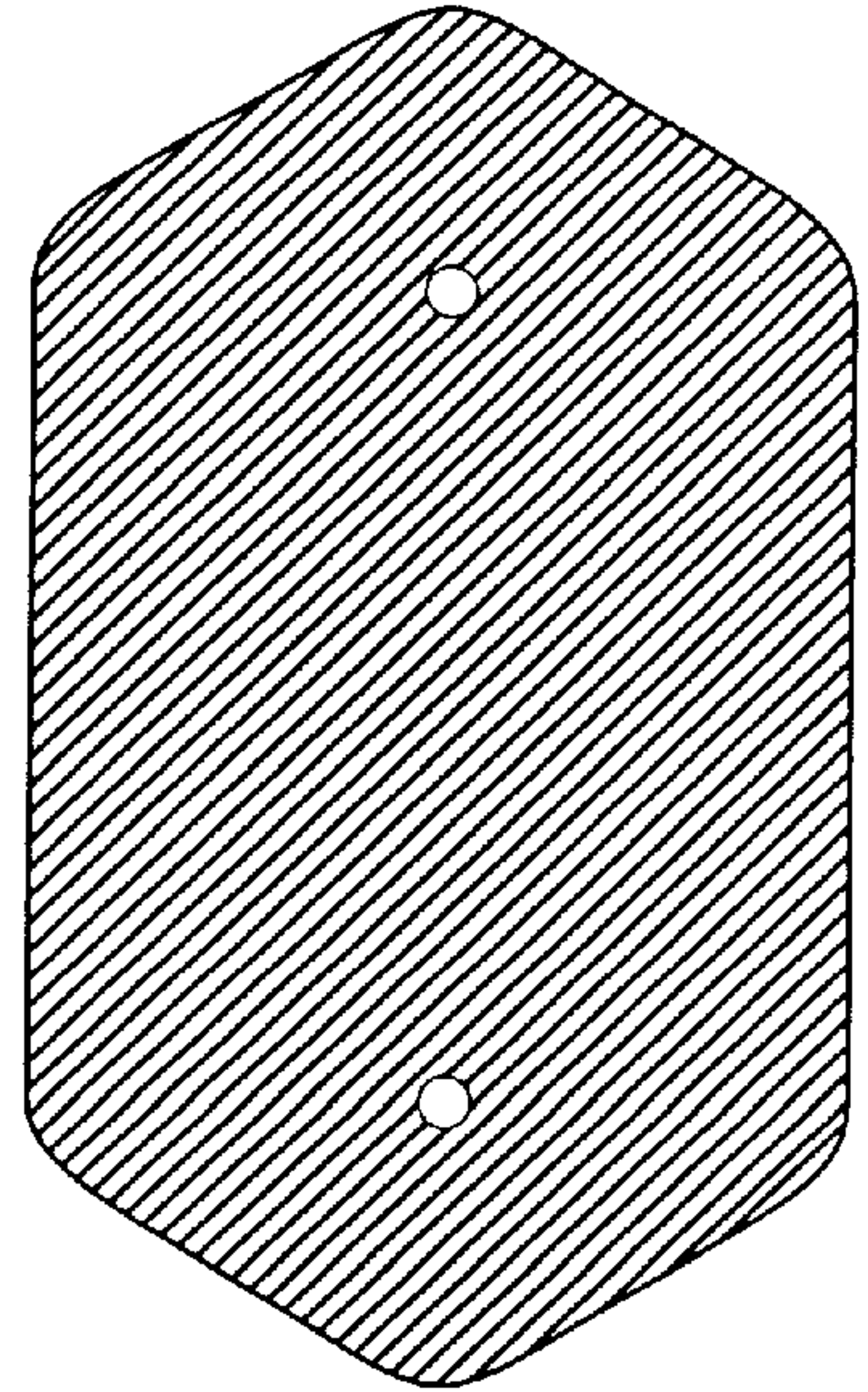

Fig. 4

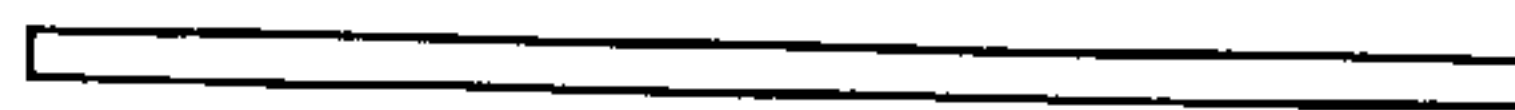

Fig. 5

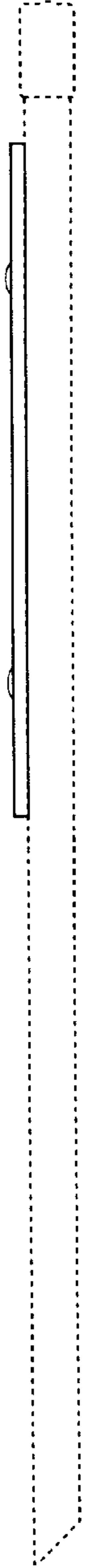

Fig. 6

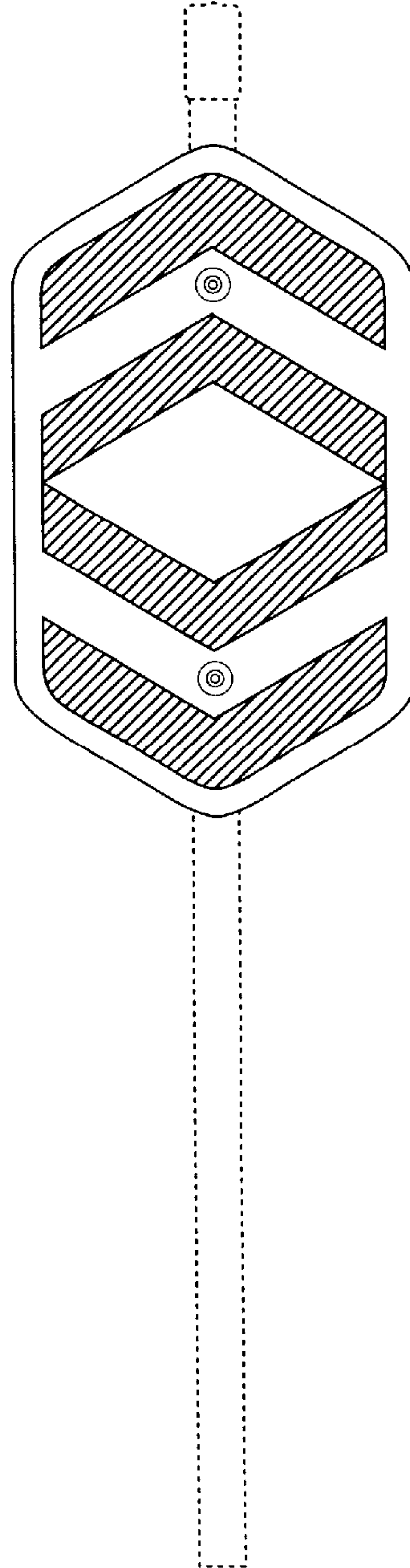

Fig. 7

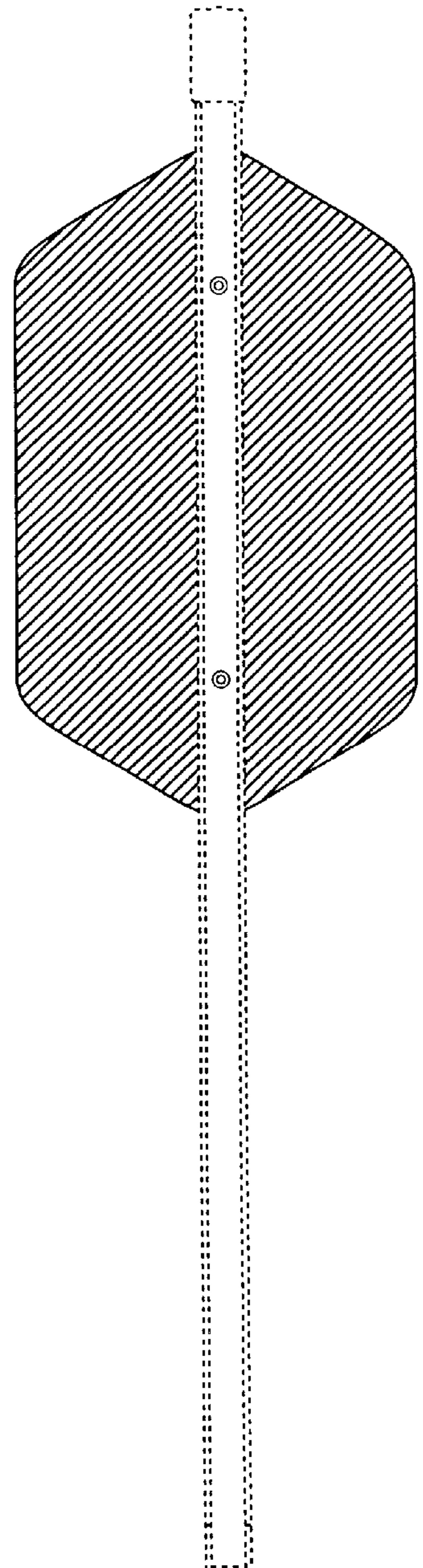

Fig. 8



Fig. 9

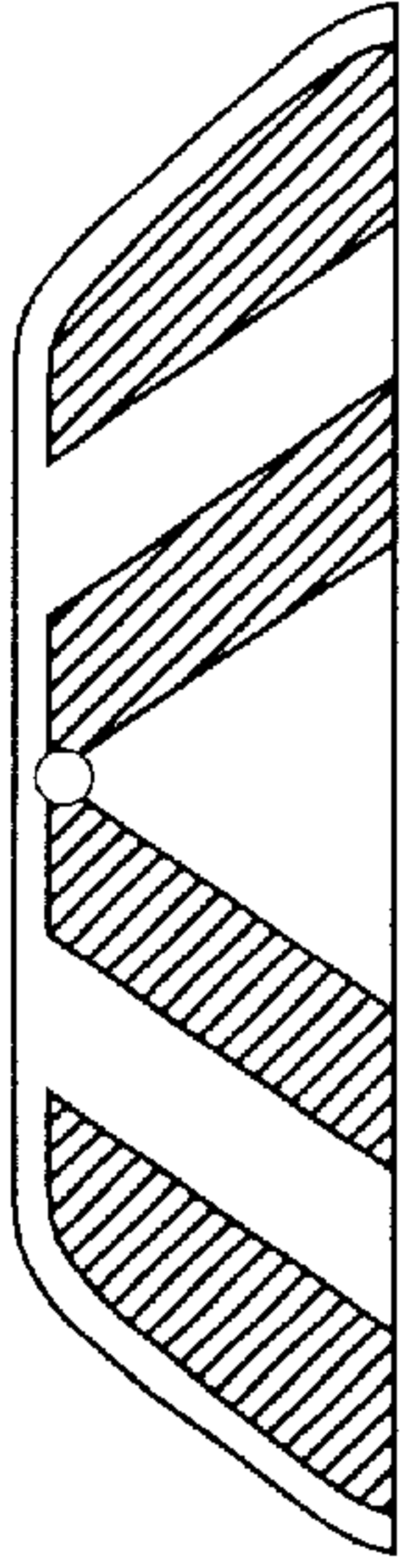

Fig. 10

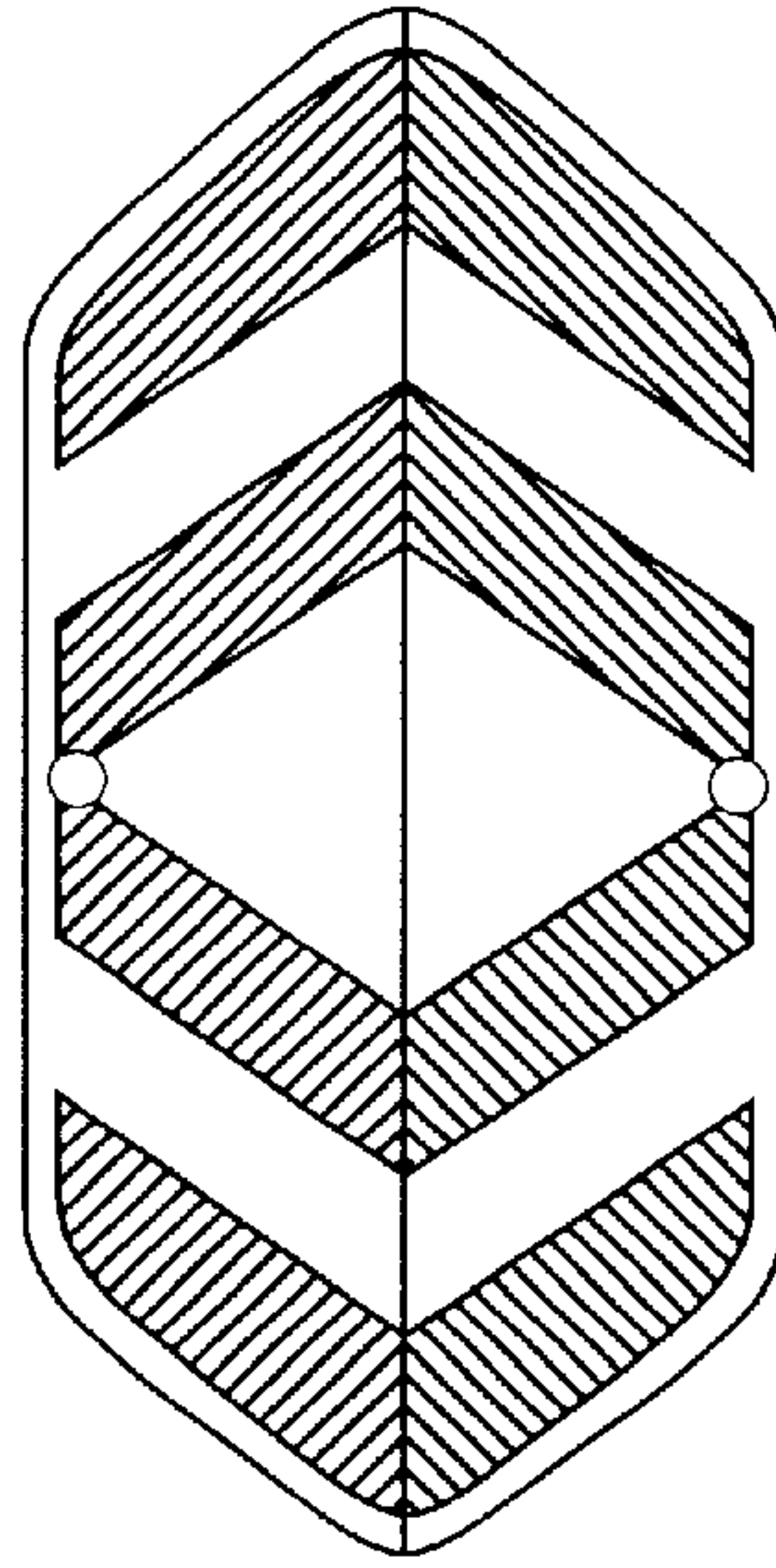

Fig. 11

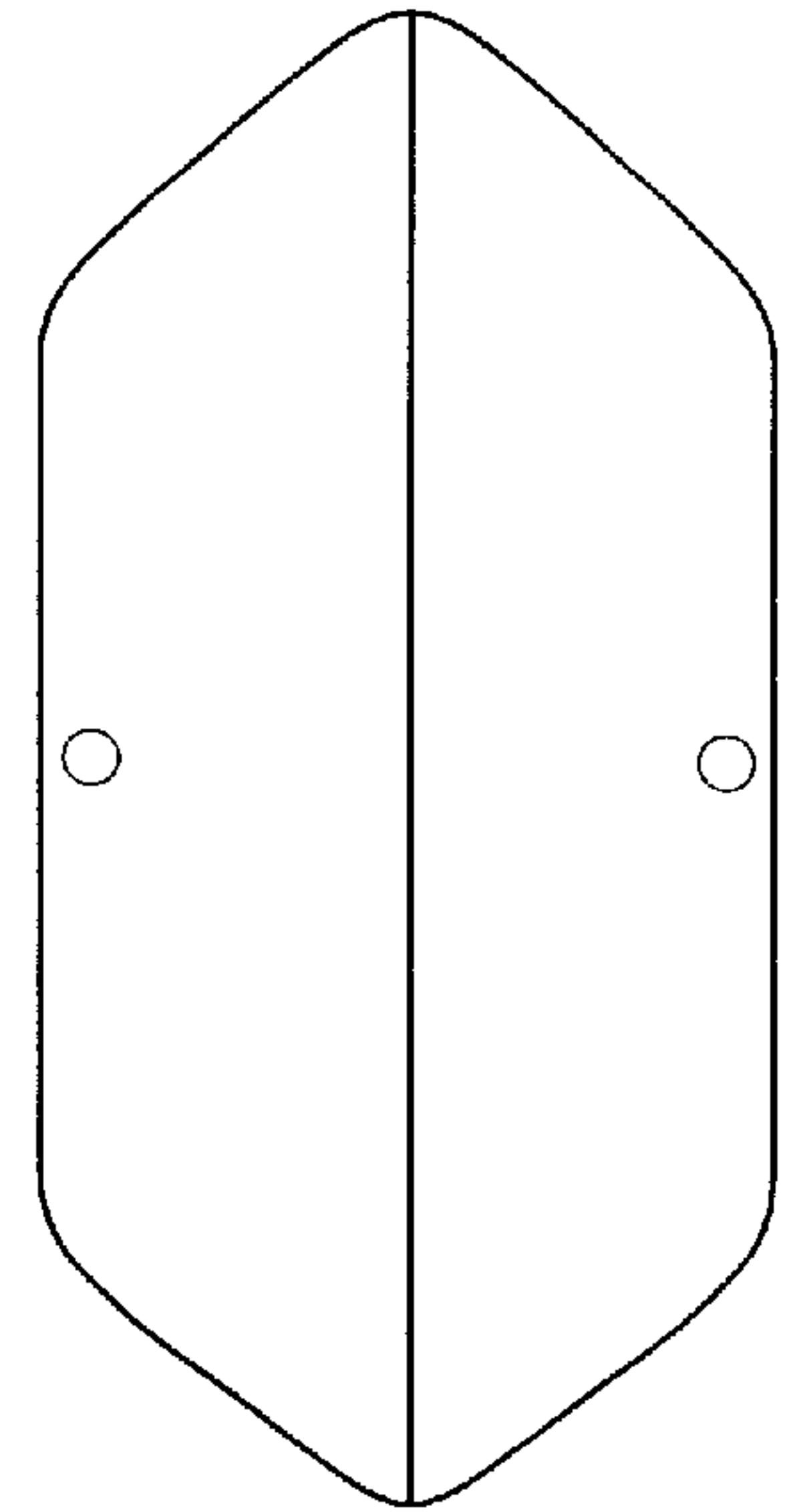

Fig. 12

