



US00D429141S

United States Patent [19]

Antonucci et al.

[11] Patent Number: **Des. 429,141**

[45] Date of Patent: **** Aug. 8, 2000**

[54] **COMPRESSION LATCH**

[75] Inventors: **Jeffrey L. Antonucci**, Norton, United Kingdom; **Thomas Weuthen**, Erkelenz, Germany

[73] Assignee: **Southco, Inc.**, Concordville, Pa.

[**] Term: **14 Years**

[21] Appl. No.: **29/106,896**

[22] Filed: **Jun. 23, 1999**

[51] **LOC (7) Cl.** **08-07**

[52] **U.S. Cl.** **D8/331**

[58] **Field of Search** D8/330, 331-346, D8/356; 70/431, 466, 448, 449, 162; 292/57, 80, 95, 121, 137, 163, 177, DIG. 11, DIG. 12; 174/153 G

[56] **References Cited**

U.S. PATENT DOCUMENTS

D. 343,782	2/1994	Gromotka et al.	D8/331
D. 357,396	4/1995	Ziemer et al.	D8/331
D. 361,711	8/1995	Plumley	D8/356
D. 364,329	11/1995	Ziemer et al.	D8/331
D. 406,748	3/1999	Byrne	D8/356
3,055,691	9/1962	Kessel	70/449
3,841,674	10/1974	Bisbing et al.	292/175

4,230,351	10/1980	Bisbing	292/223
4,693,503	9/1987	Bisbing	292/210
4,880,261	11/1989	Bisbing	292/7
5,064,228	11/1991	Bisbing	292/54
5,267,762	12/1993	Gromotka	292/229
5,409,272	4/1995	McCormack	292/66
5,934,716	8/1999	Koveal et al.	292/175

OTHER PUBLICATIONS

Southco Handbook 48NA—pp. F4-F5, and L6-L7.

Primary Examiner—Susan J. Lucas

Assistant Examiner—Jennifer Rivard

Attorney, Agent, or Firm—Paul & Paul

[57] **CLAIM**

The ornamental design for a compression latch, as shown and described.

DESCRIPTION

FIG. 1 is a top, right side perspective view of a compression latch showing our new design; FIG. 2 is a left side elevation view thereof, the right side being a mirror image of the right side; FIG. 3 is a top plan view thereof; FIG. 4 is a front elevation view thereof; FIG. 5 is an enlarged bottom plan view thereof; and, FIG. 6 is an enlarged rear elevation view thereof.

1 Claim, 2 Drawing Sheets

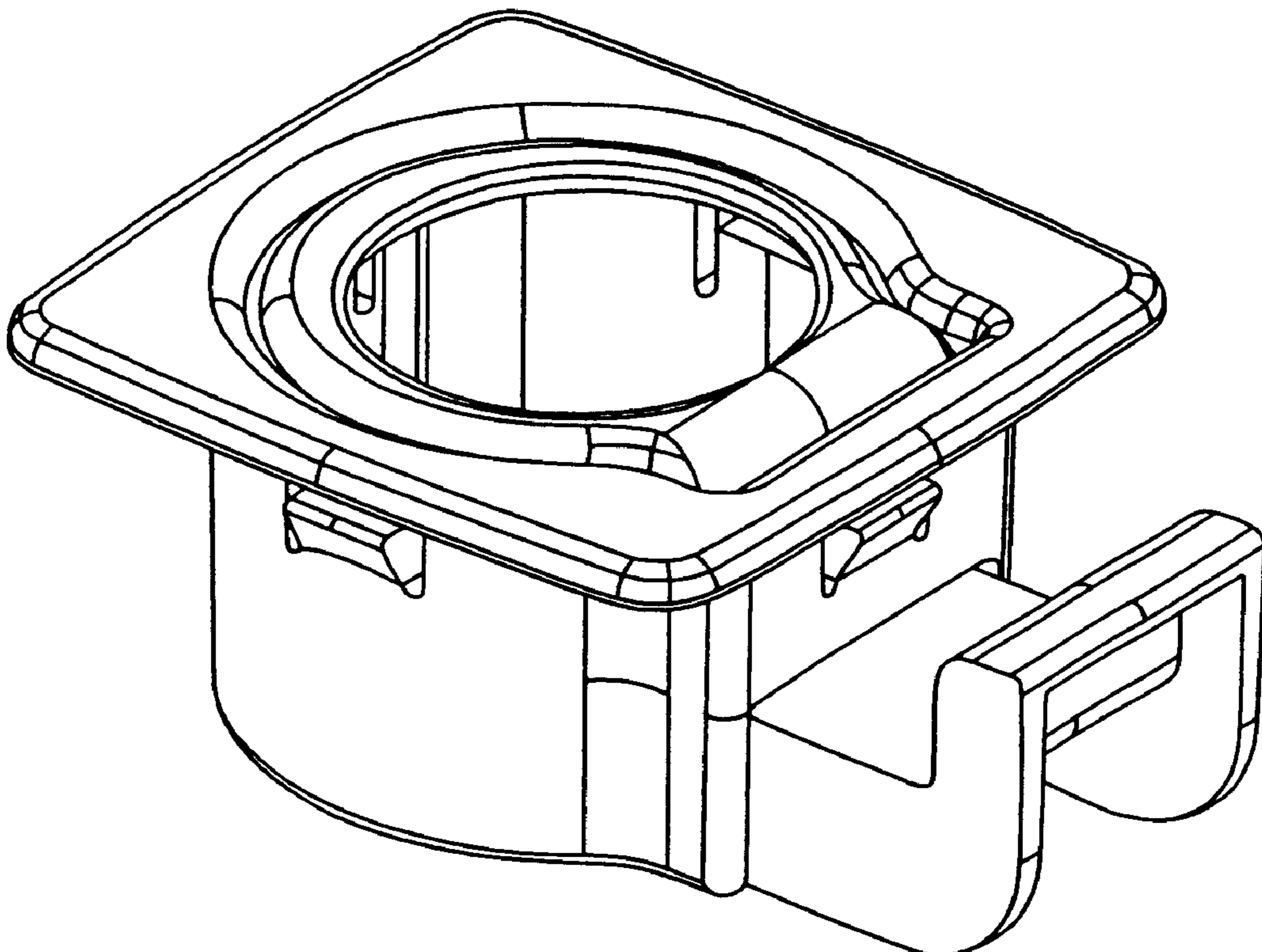

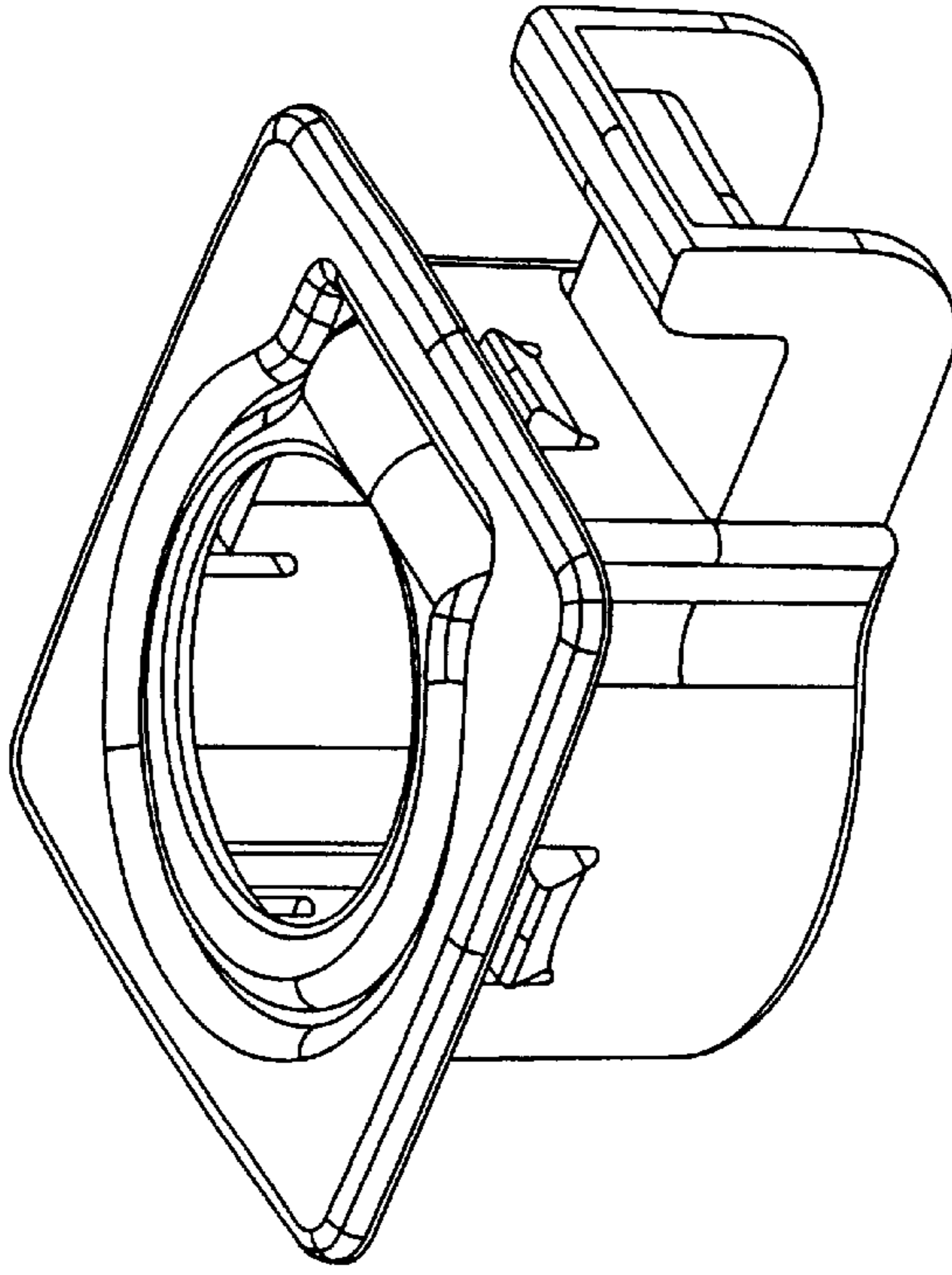

FIG. 1

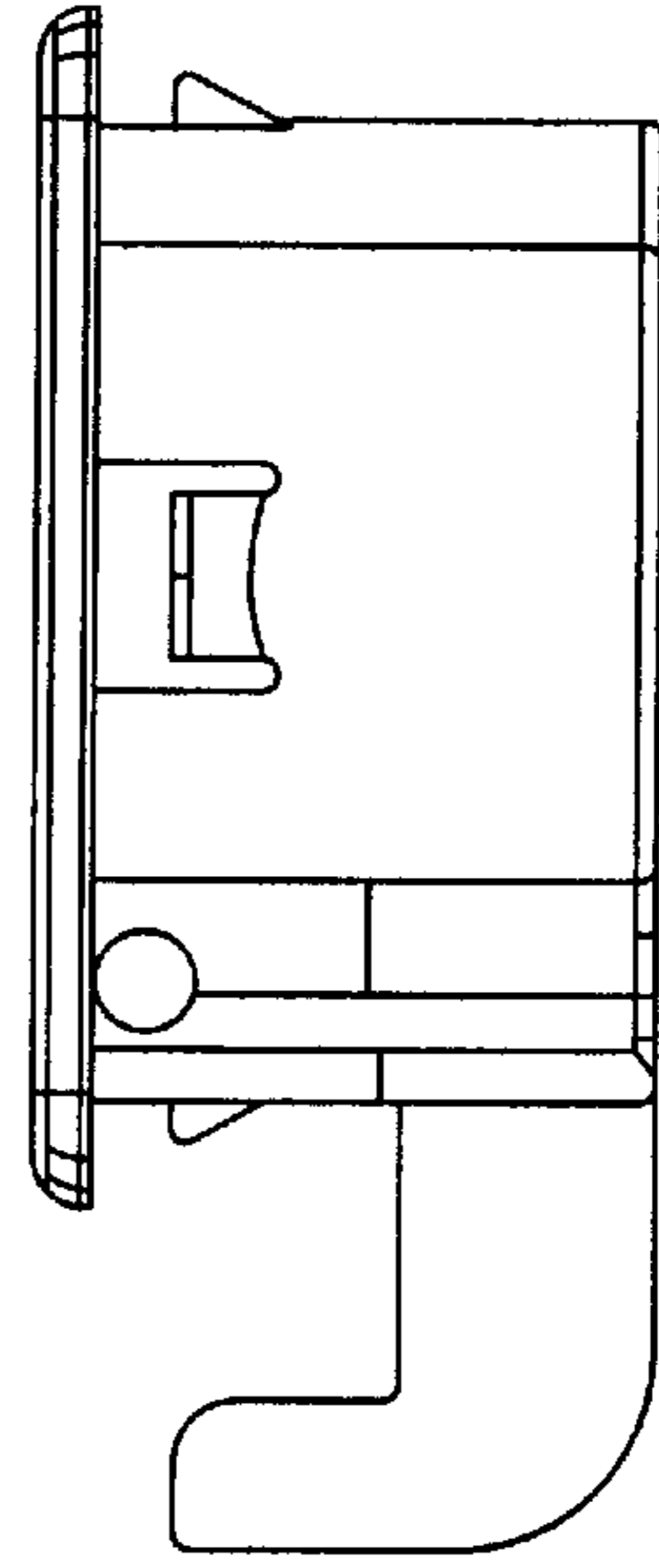

FIG. 2

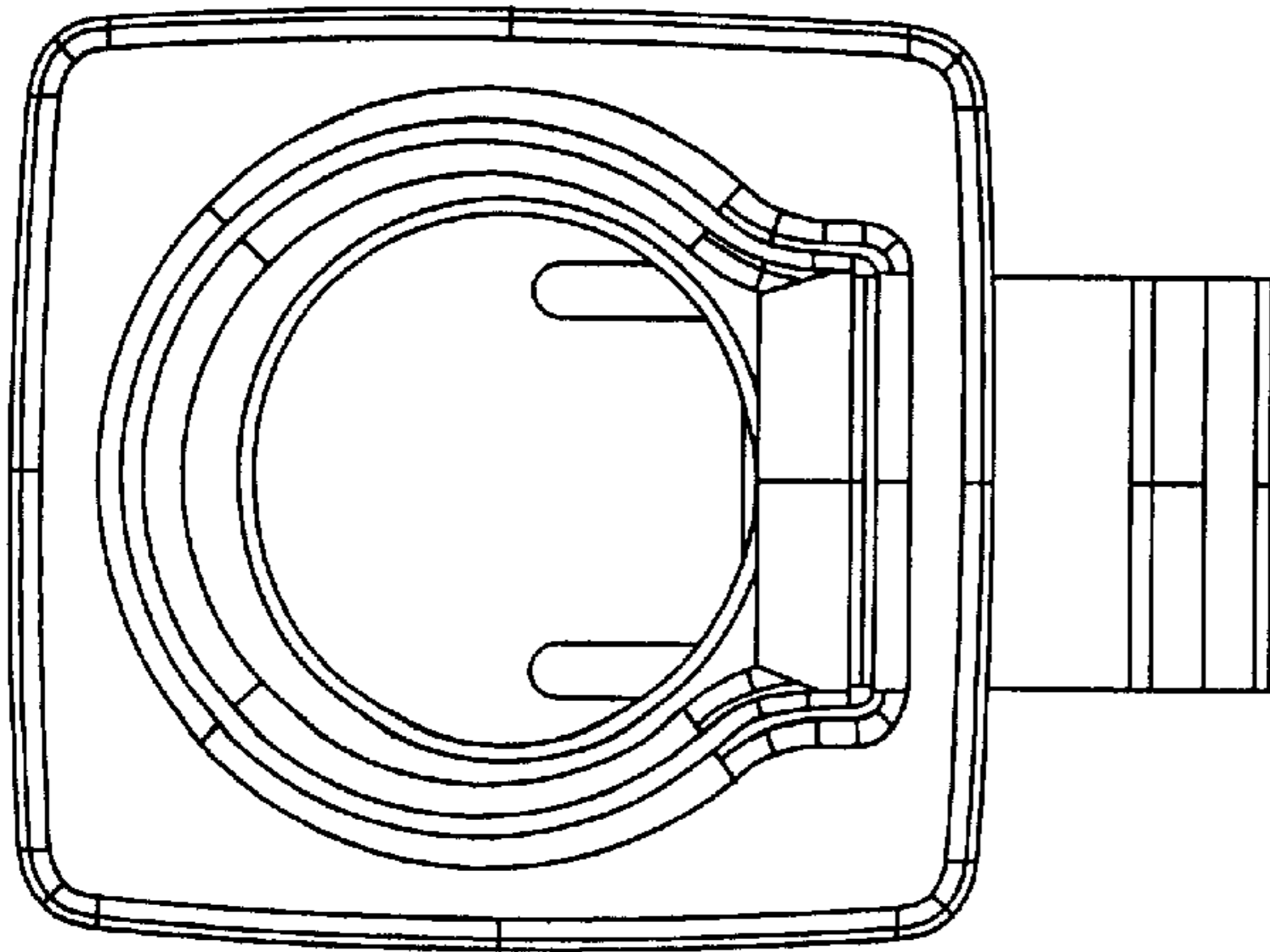

FIG. 3

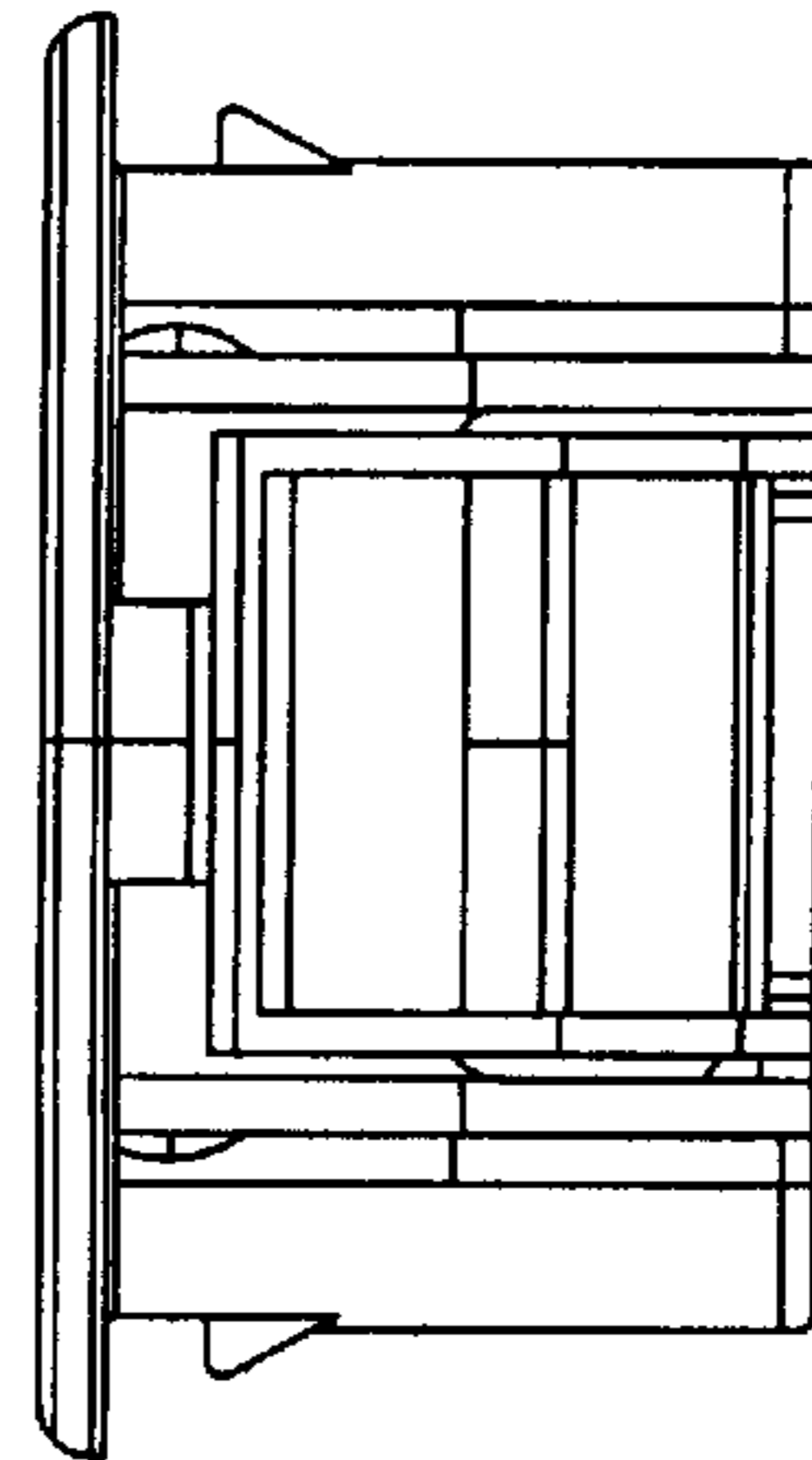

FIG. 4

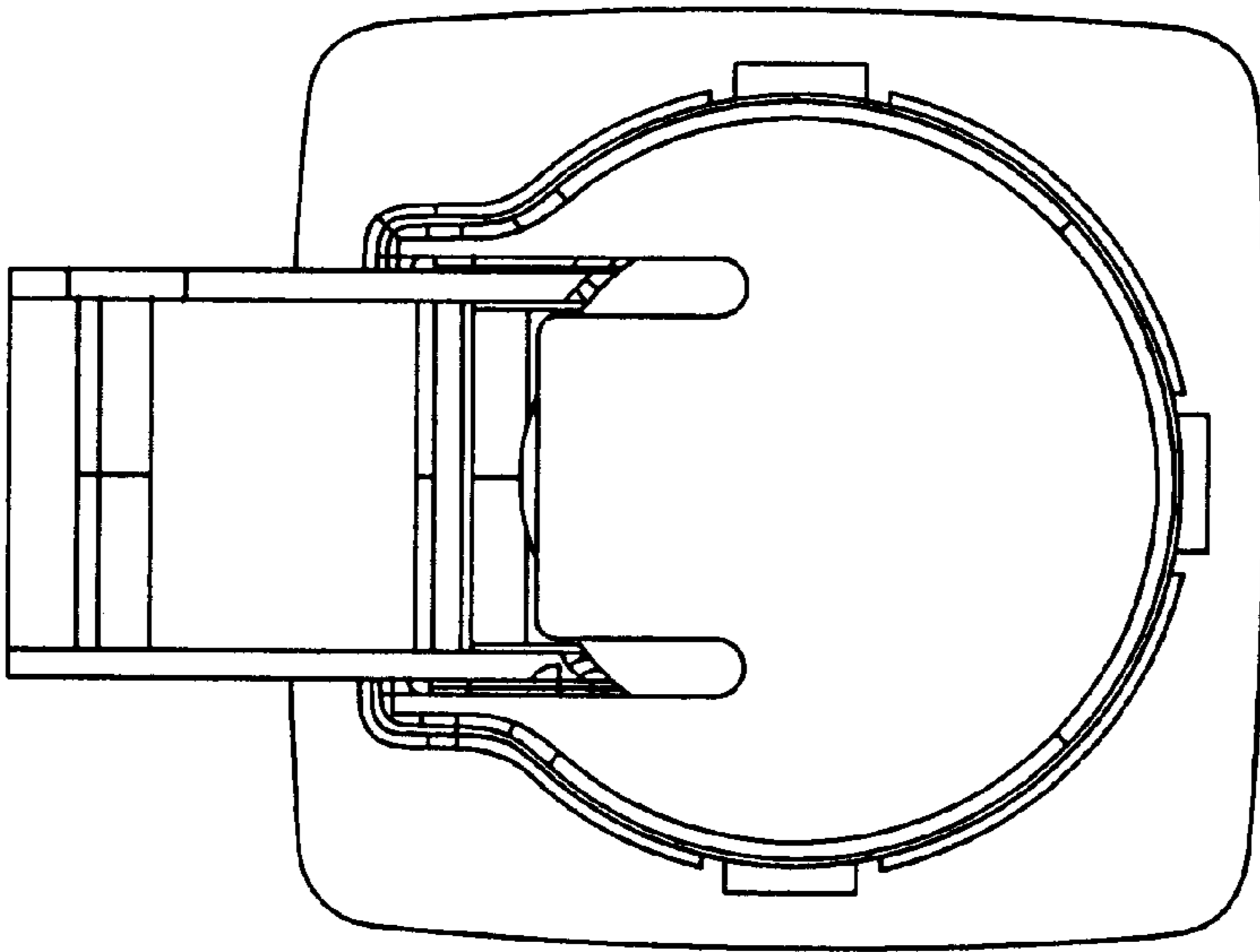

FIG. 5

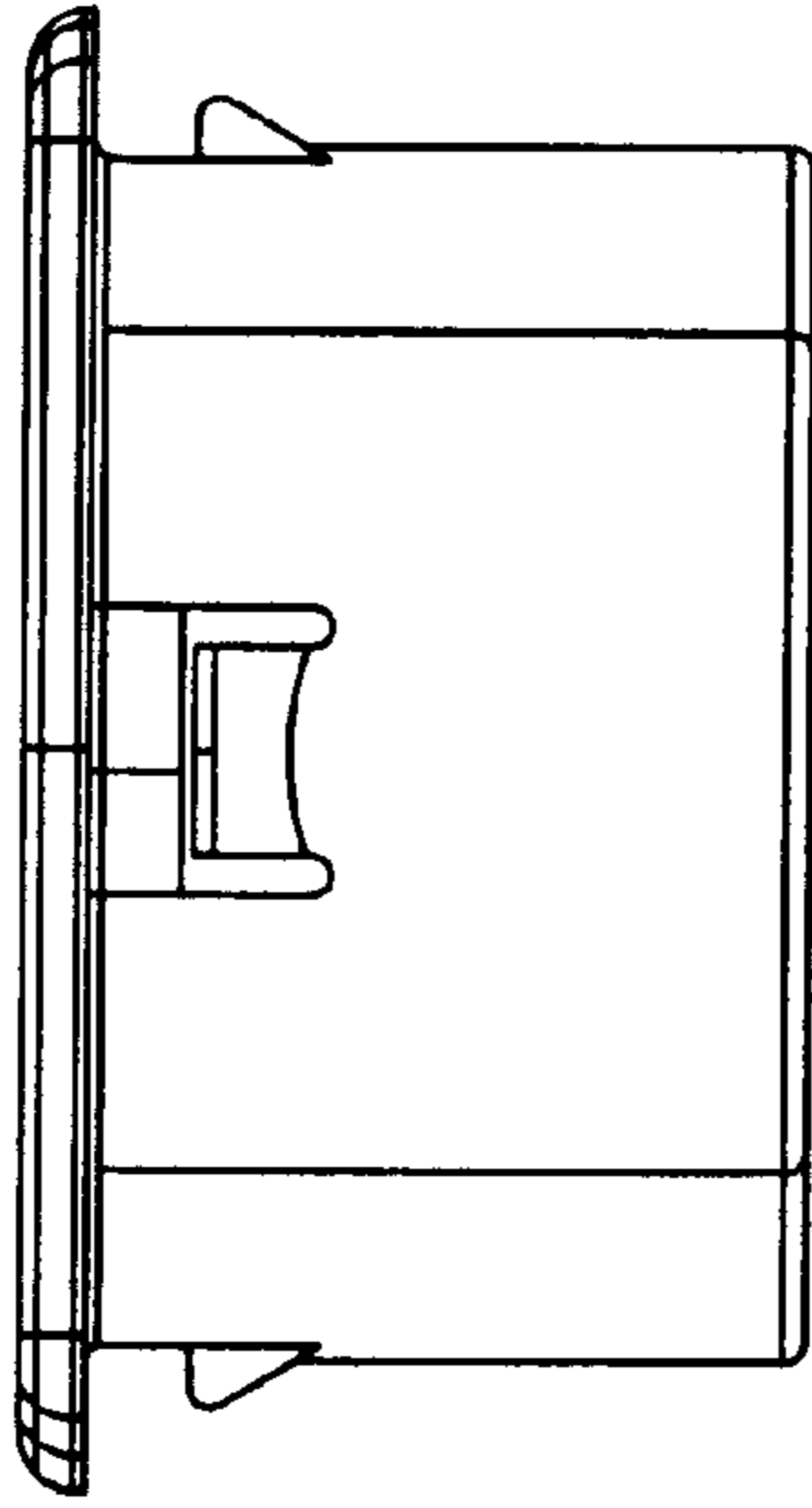

FIG. 6