



US00D429088S

United States Patent [19]

[11] Patent Number: Des. 429,088

Lechman

[45] Date of Patent: ** *Aug. 8, 2000

[54] MODULAR TRAPEZOIDAL CLASSROOM DESK

[75] Inventor: John N. Lechman, Effingham, Ill.

[73] Assignee: Nova Solutions, Inc., Effingham, Ill.

[*] Notice: This patent is subject to a terminal disclaimer.

[**] Term: 14 Years

[21] Appl. No.: 29/089,125

[22] Filed: Jun. 8, 1998

[51] LOC (7) Cl. 06-04

[52] U.S. Cl. D6/423

[58] Field of Search D6/422-428; 108/60, 108/64, 111; 312/194, 195, 196, 203, 223.3

[56] References Cited

U.S. PATENT DOCUMENTS

D. 329,551	9/1992	Lechman	D6/422
D. 335,047	4/1993	Lechman et al.	D6/422
D. 335,782	5/1993	Lechman et al.	D6/422
D. 342,396	12/1993	Lechman et al.	D6/422
D. 346,913	5/1994	Lechman et al.	D6/427
D. 372,601	8/1996	Roberts et al.	D6/422
2,871,073	1/1959	Swanson	108/64 X
5,572,935	11/1996	Schairbaum	108/50
5,651,594	7/1997	Lechman	312/194
5,655,822	8/1997	Roberts et al.	312/194
5,740,743	4/1998	Schairbaum	108/25
5,964,164	10/1999	Lechman	108/109

Primary Examiner—Cathron B. Matta
Attorney, Agent, or Firm—Olson & Hierl, Ltd.

[57] CLAIM

The ornamental design for a modular trapezoidal classroom desk, as shown and described.

DESCRIPTION

The computer monitor and the computer keyboard shown in broken lines in selected ones of the accompanying drawings do not form a part of the modular desk design of my invention.

FIG. 1 is a perspective view of the modular trapezoidal classroom desk of my invention;

FIG. 2 is a top plan view of the medial classroom desk of FIG. 1 with the respective left and right opposite side bottom shelves in place and with the left and right back side doors in their closed positions, the medial desk being shown alone for completeness of illustration;

FIG. 3 is a left side (relative to FIG. 1) elevational view of the medial classroom desk of FIG. 2 with the left side bottom shelf in place;

FIG. 4 is a right side (relative to FIG. 1) elevational view of the medial classroom desk of FIG. 2 with the right side bottom shelf in place;

FIG. 5 is a front side (relative to FIG. 1) elevational view of the medial classroom desk of FIG. 2 with the opposite left and right side bottom shelves in and with the left and right back side doors in their closed positions;

FIG. 6 is a back side (relative to FIG. 1) elevational view of the medial classroom desk of FIG. 2 with the left and right back side doors in their closed positions, and with respective opposite left and right side bottom shelves in place;

FIG. 7 is a bottom plan view of the medial classroom desk of FIG. 2 with the opposite left and right side bottom shelves in place and with the left and right back doors in their closed positions;

FIG. 8 is a top plan view of the left classroom desk of FIG. 1, but with the right side bottom shelf removed, the left desk being shown alone for completeness of illustration;

FIG. 9 is a right side (relative to FIG. 1) elevational view of the left classroom desk of FIG. 8 with the right side bottom shelf removed;

FIG. 10 is a left side (relative to FIG. 1) elevational view of the left classroom desk of FIG. 8;

FIG. 11 is a front side (relative to FIG. 1) elevational view of the left classroom desk of FIG. 8 with the right bottom shelf removed and with the left and right back side doors in their respective closed positions;

FIG. 12 is a back side (relative to FIG. 1) elevational view of the left classroom desk of FIG. 8 with the left and right back side doors in their closed positions, and with the right bottom shelf removed;

FIG. 13 is a bottom plan view of the left classroom desk of FIG. 8 with the left bottom shelf in place and the right bottom shelf removed and with the left and right back side doors in their respective closed positions;

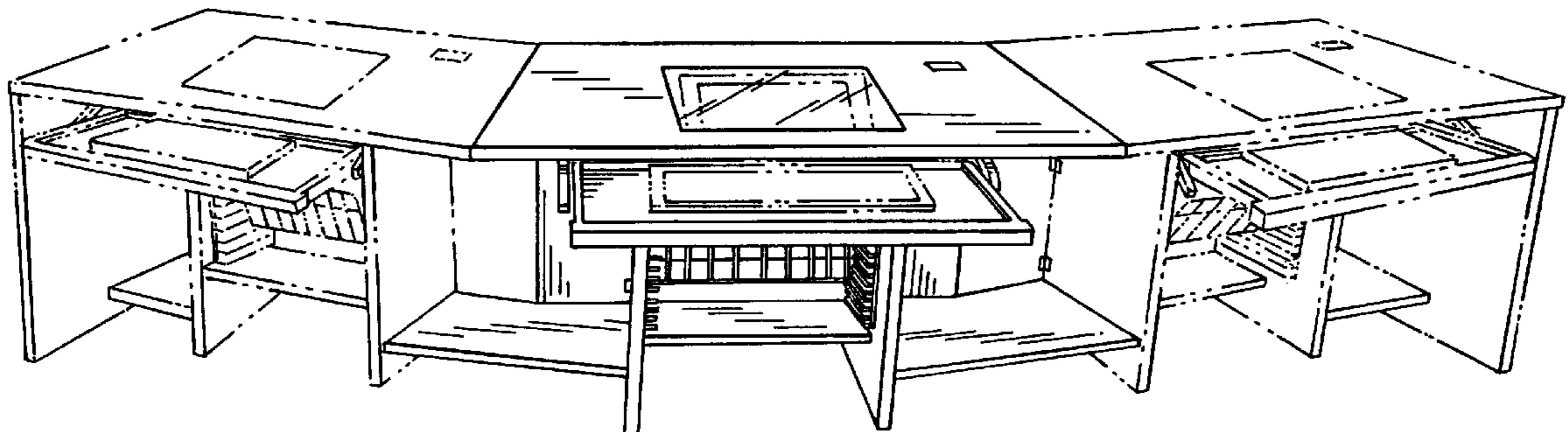

FIG. 14 is a top plan view of the right classroom desk of FIG. 1, but with the left side bottom shelf removed, the right desk being shown alone for completeness of illustration;

FIG. 15 is a left side (relative to FIG. 1) elevational view of the right classroom desk of FIG. 14 with the left side bottom shelf removed;

FIG. 16 is a right side (relative to FIG. 1) elevational view of the right classroom desk of FIG. 14;

FIG. 17 is a front side (relative to FIG. 1) elevational view of the right classroom desk of FIG. 14, with the left side bottom shelf removed and with the left and right back side doors in their respective closed positions;

FIG. 18 is a back side (relative to FIG. 1) elevational view of the right classroom desk of FIG. 14 with the right and left back side doors in closed positions, and with the left bottom shelf removed;

FIG. 19 is a bottom plan view of the right classroom desk of FIG. 14 with the left bottom shelf removed and right bottom shelf in place and with the left and right back side doors in their closed positions;

FIG. 20 is a view similar to FIG. 2 but with the respective left and right side doors in their open positions;

FIG. 21 is a view similar to FIG. 4 but with the right side door in its open position;

FIG. 22 is a view similar to FIG. 3 with the left side door in its open position;

FIG. 23 is a view similar to FIG. 5 but with the left and right back side doors in their open positions;

FIG. 24 is a view similar to FIG. 6 but with the left and right back side doors in their open positions;

FIG. 25 is a view similar to FIG. 7 but with the left and right back side doors in their open positions;

FIG. 26 is a view similar to FIG. 8 but with the left and right back side doors in their open positions;

FIG. 27 is a view similar to FIG. 9 but with the left and right back side doors in their open positions;

FIG. 28 is a view similar to FIG. 10 but with the left and right back side doors in their open positions;

FIG. 29 is a view similar to FIG. 11 but with the left and right back side doors in their open positions;

FIG. 30 is a view similar to FIG. 12 but with the left and right back side doors in their open positions;

FIG. 31 is a view similar to FIG. 13 but with the left and right back side doors in their open positions;

FIG. 32 is a view similar to FIG. 14 but with the left and right back side doors in their open positions;

FIG. 33 is a view similar to FIG. 15 but with the left and right back side doors in their open positions;

FIG. 34 is a view similar to FIG. 16 but with the left and right back side doors in their open positions;

FIG. 35 is a view similar to FIG. 17 but with the left and right back side doors in their open positions; and,

FIG. 36 is a view similar to FIG. 18 but with the left and right back side doors in their open positions.

1 Claim, 9 Drawing Sheets

FIG. 1

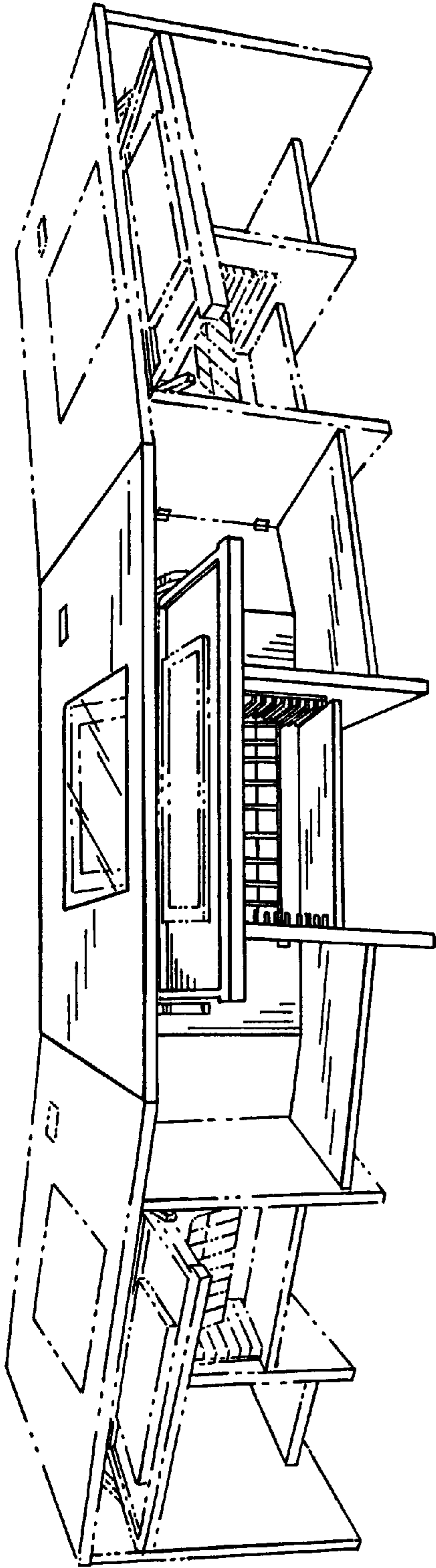

FIG. 2

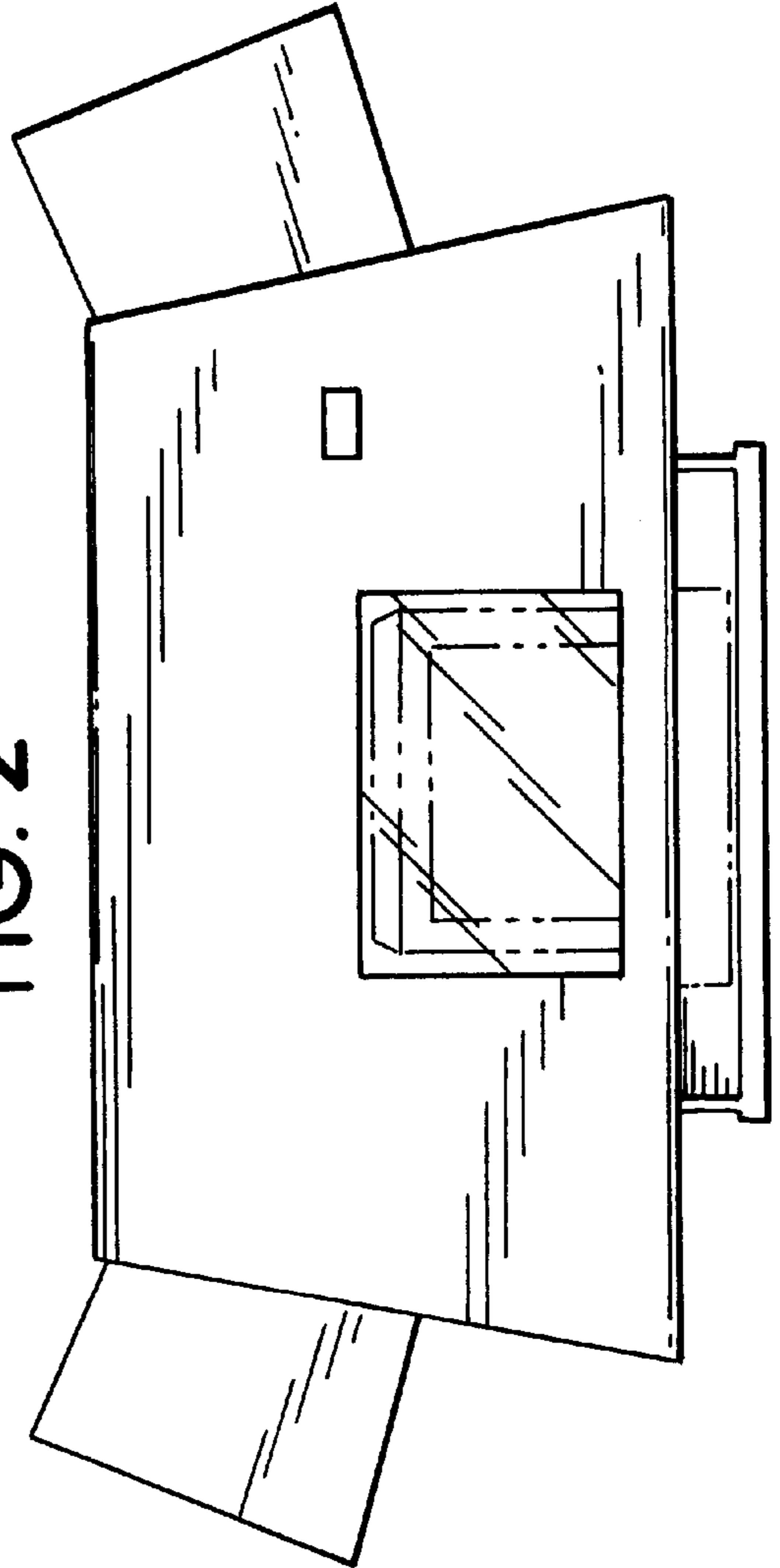

FIG. 3

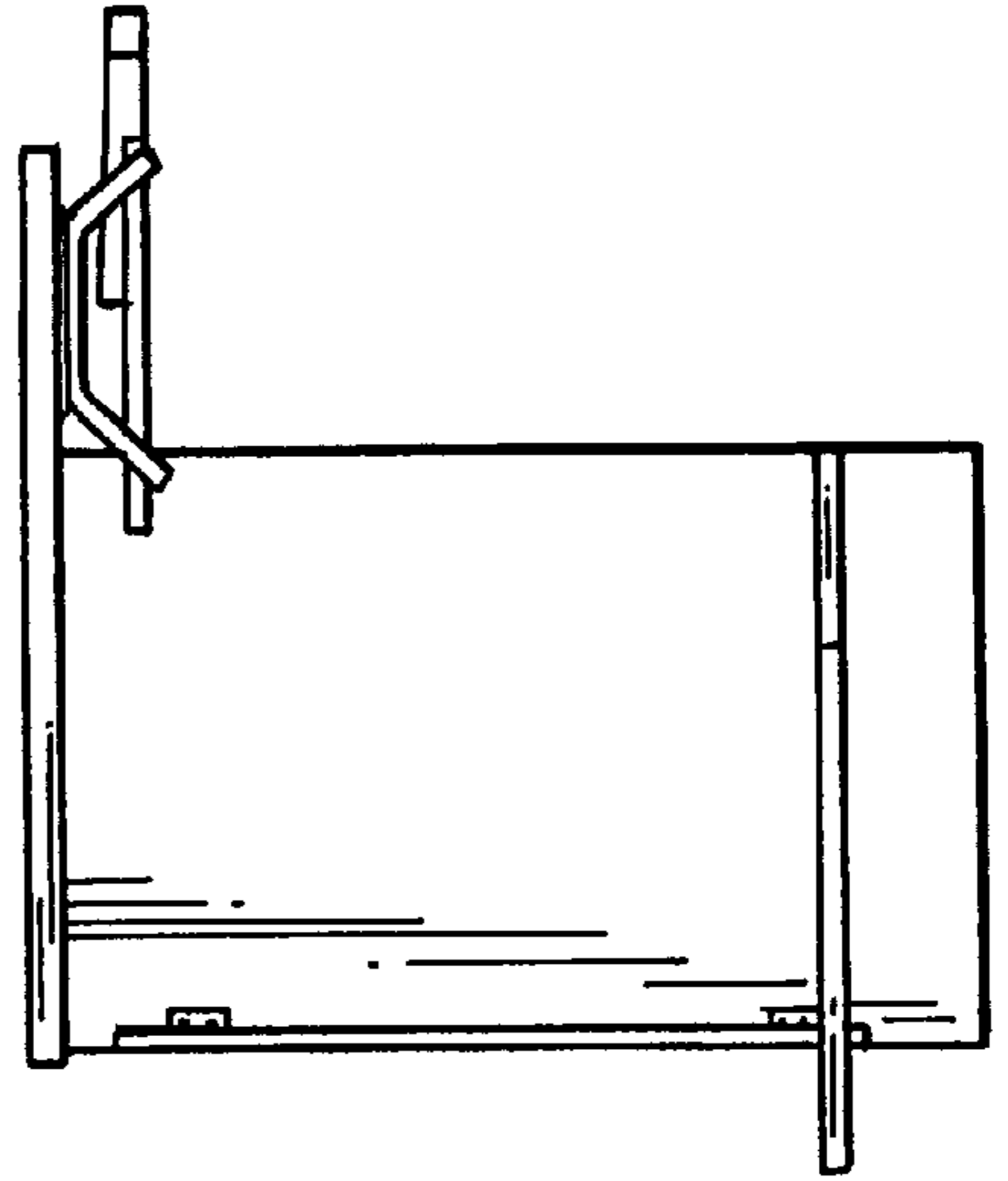

FIG. 4

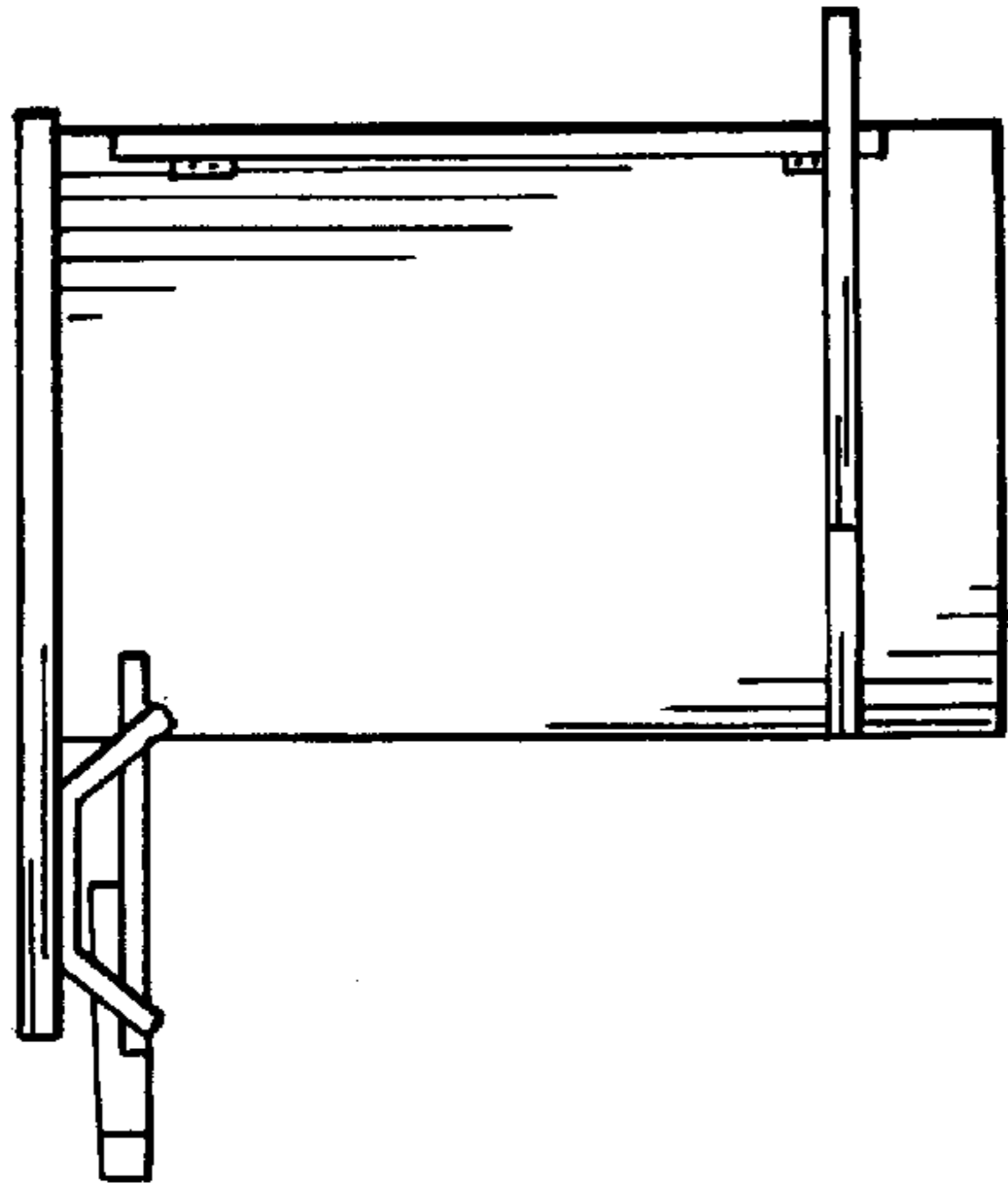

FIG. 5

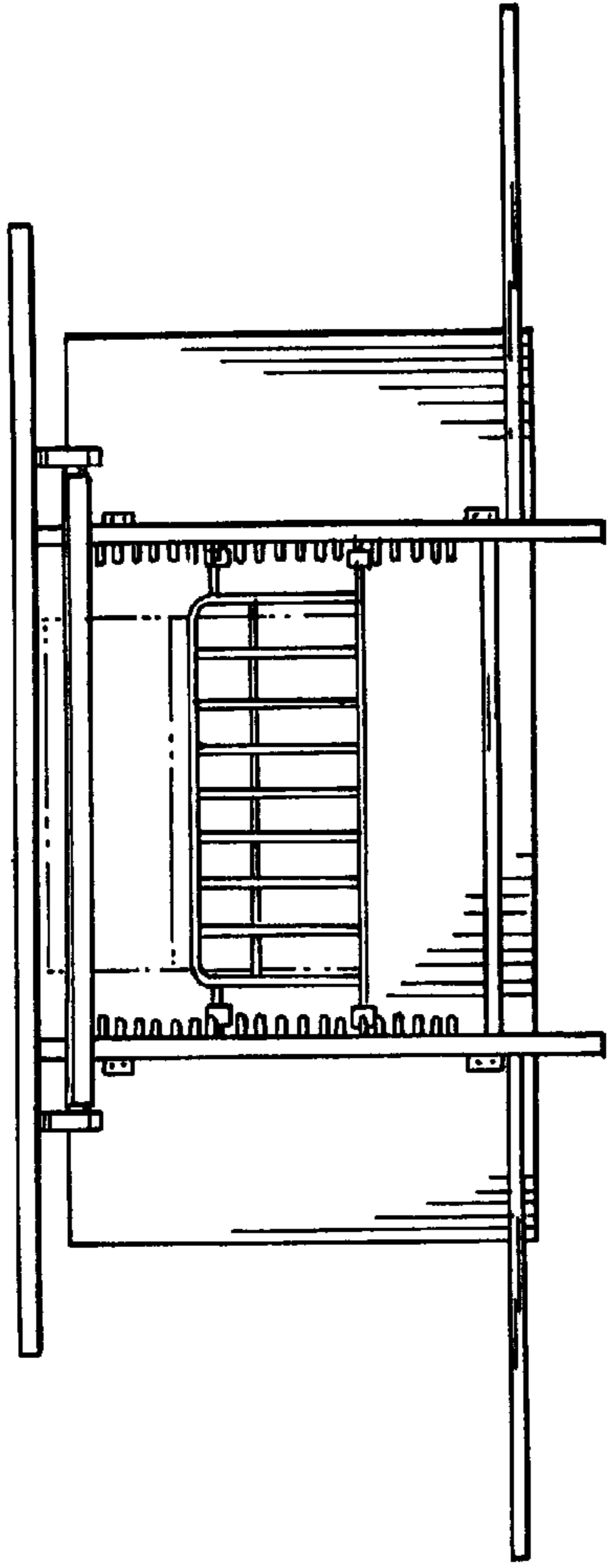

FIG. 7

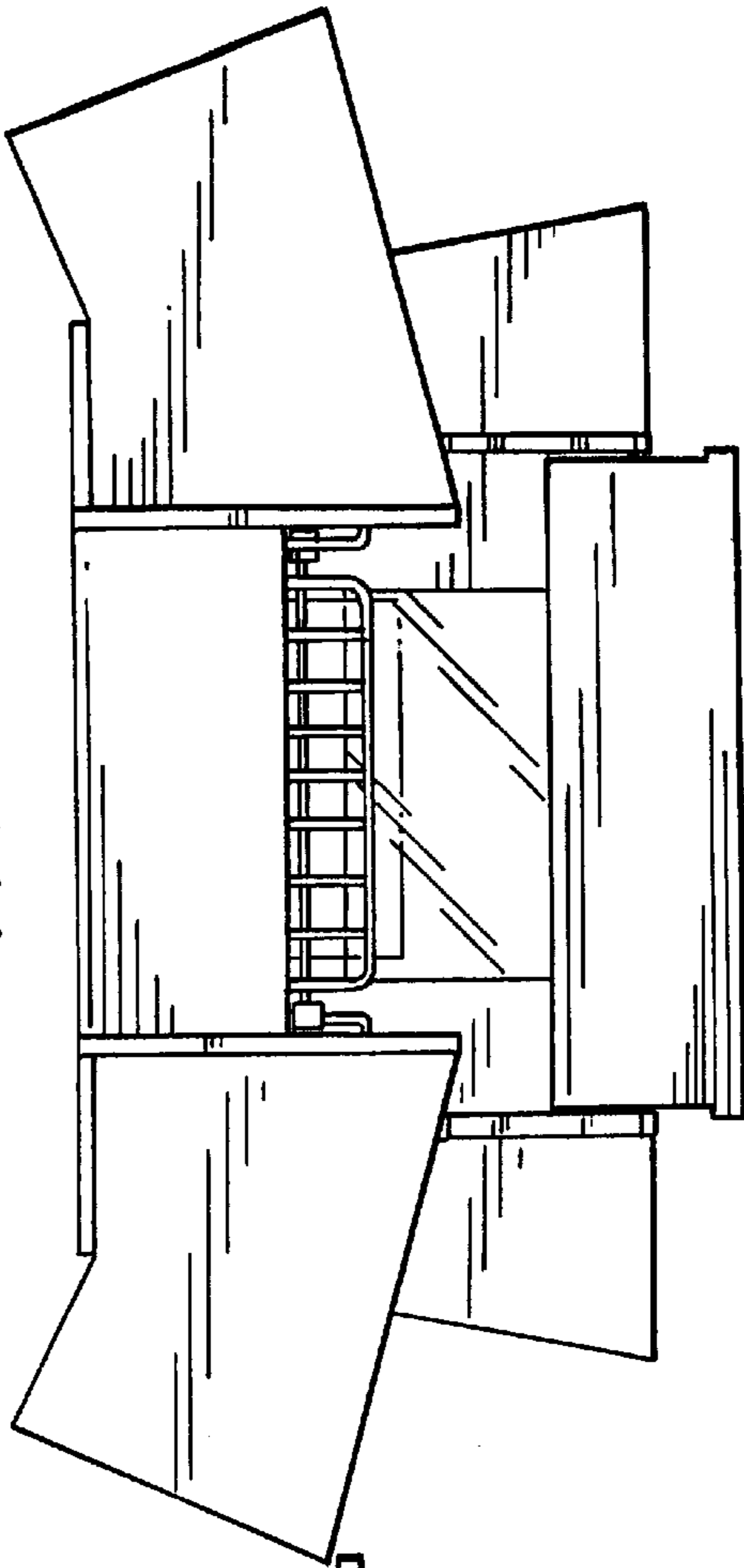

FIG. 6

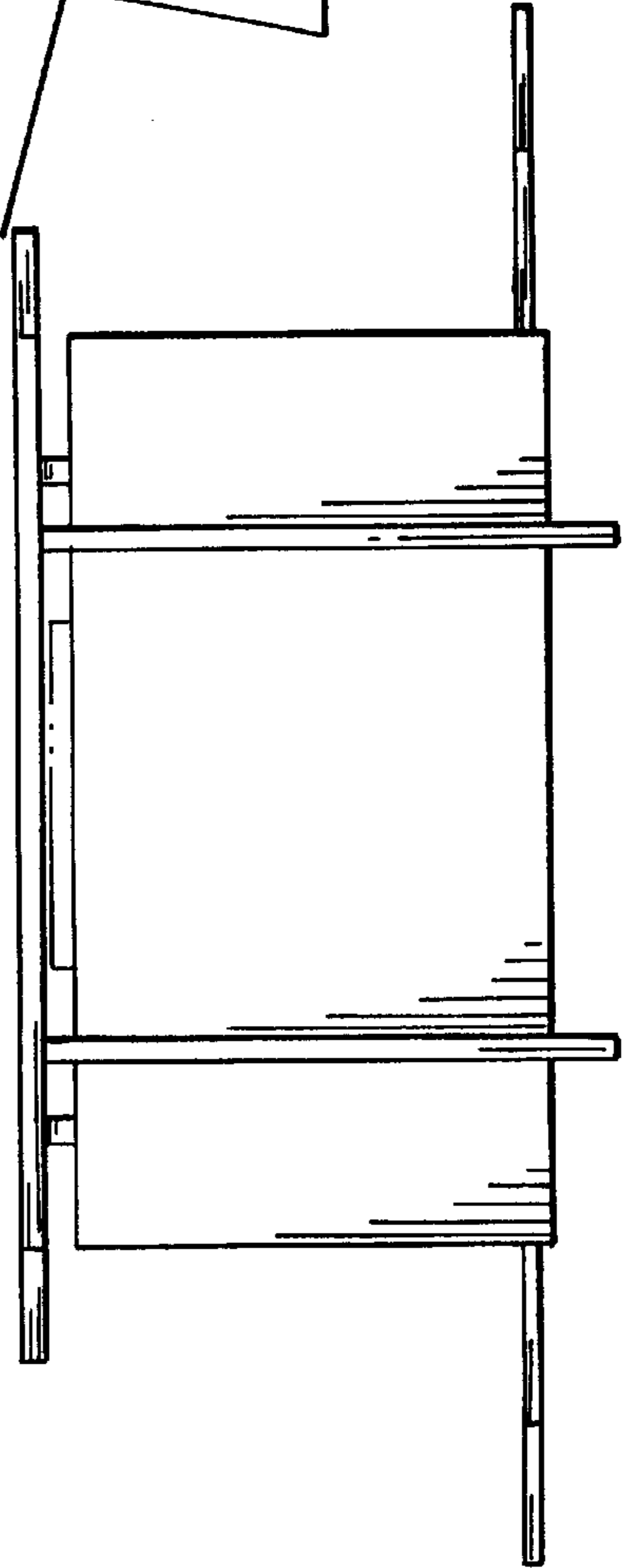

FIG. 9

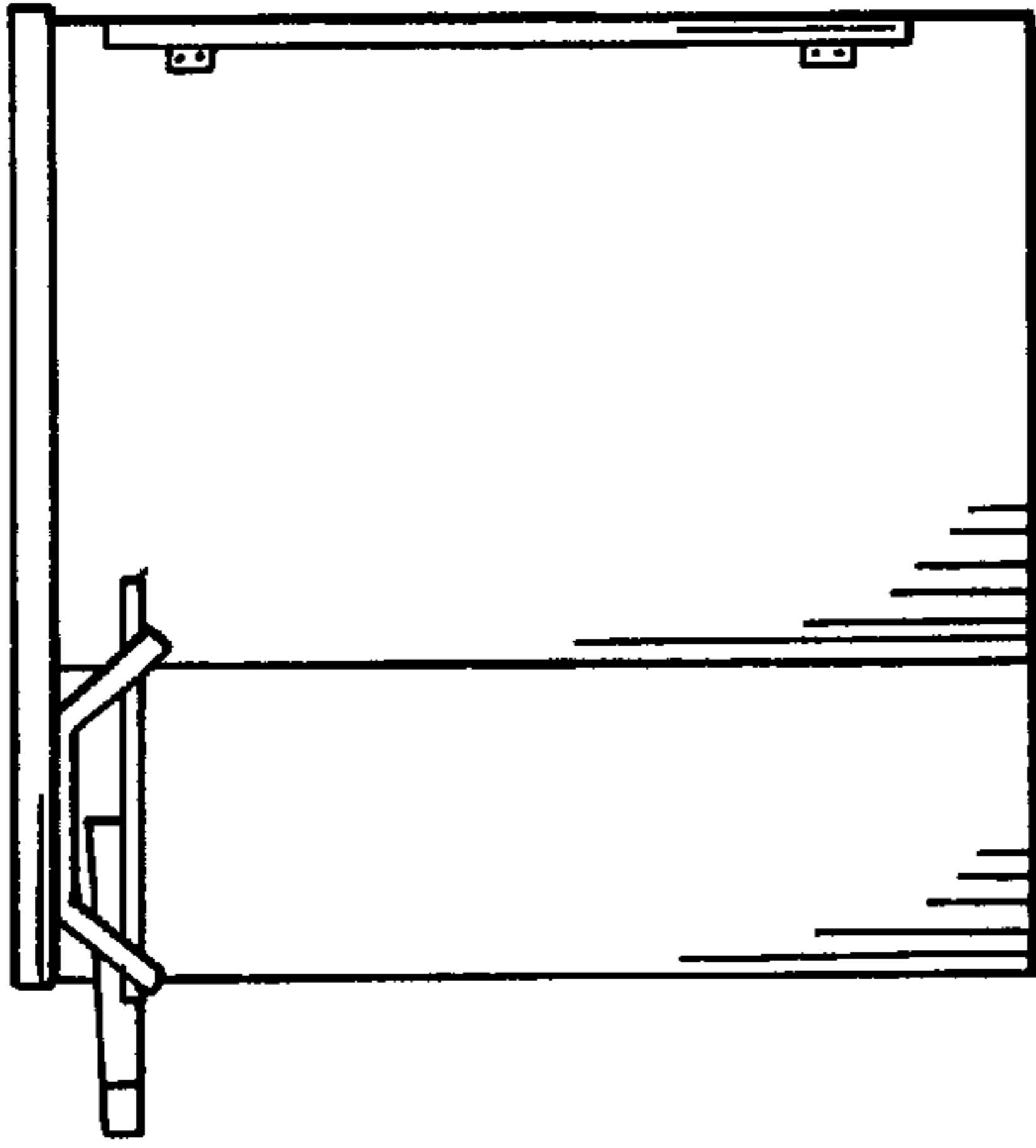

FIG. 8

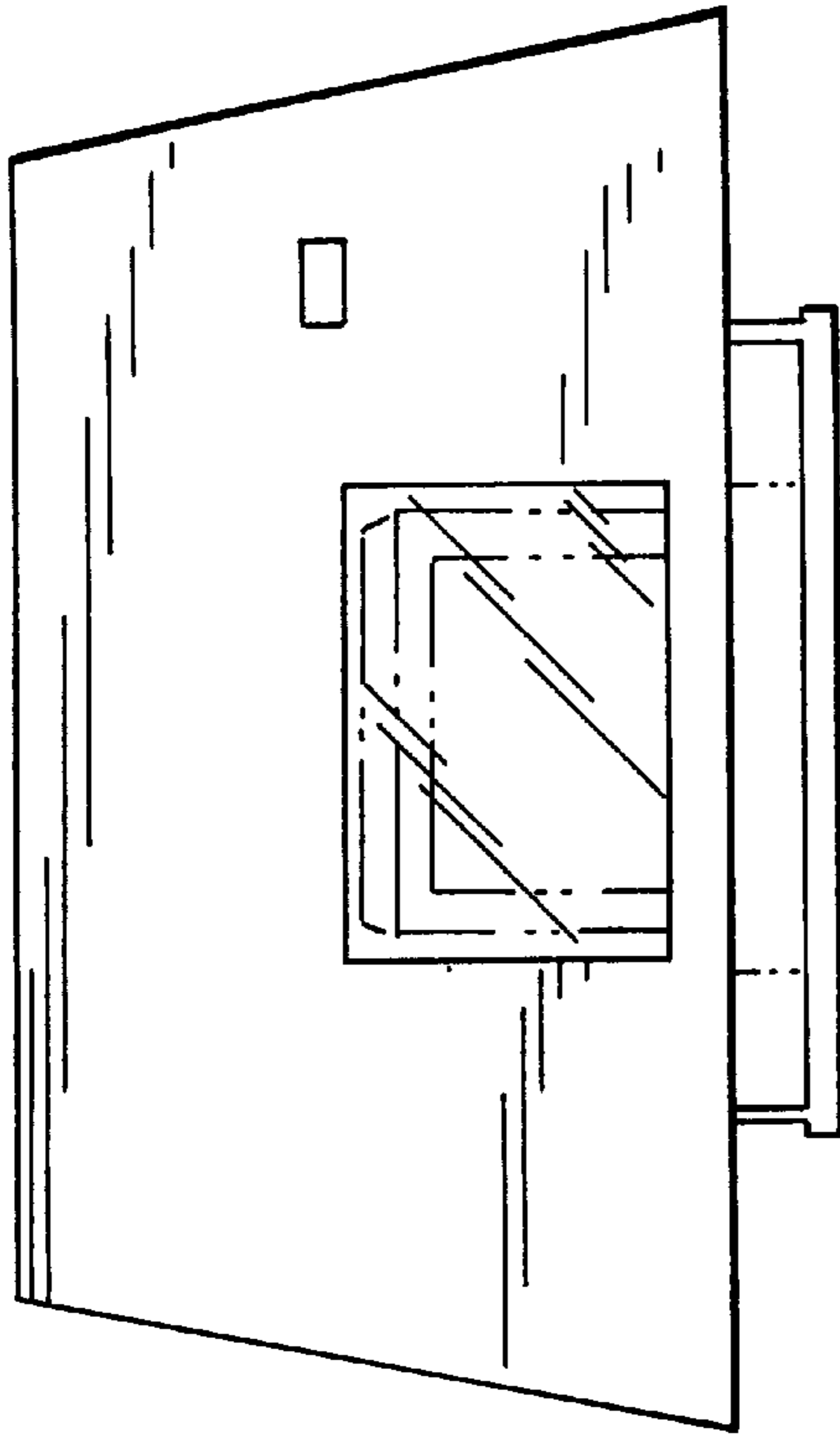

FIG. 11

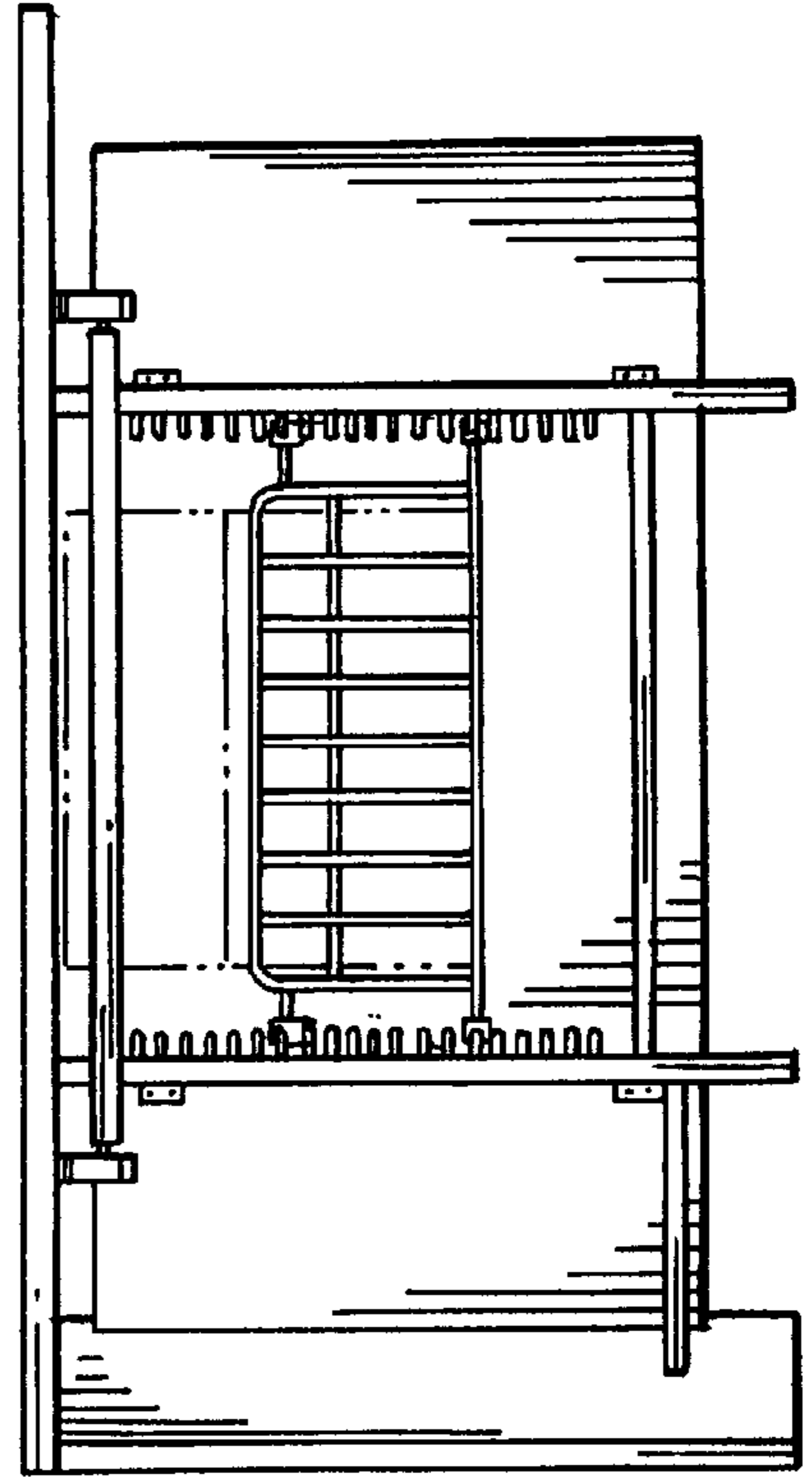

FIG. 10

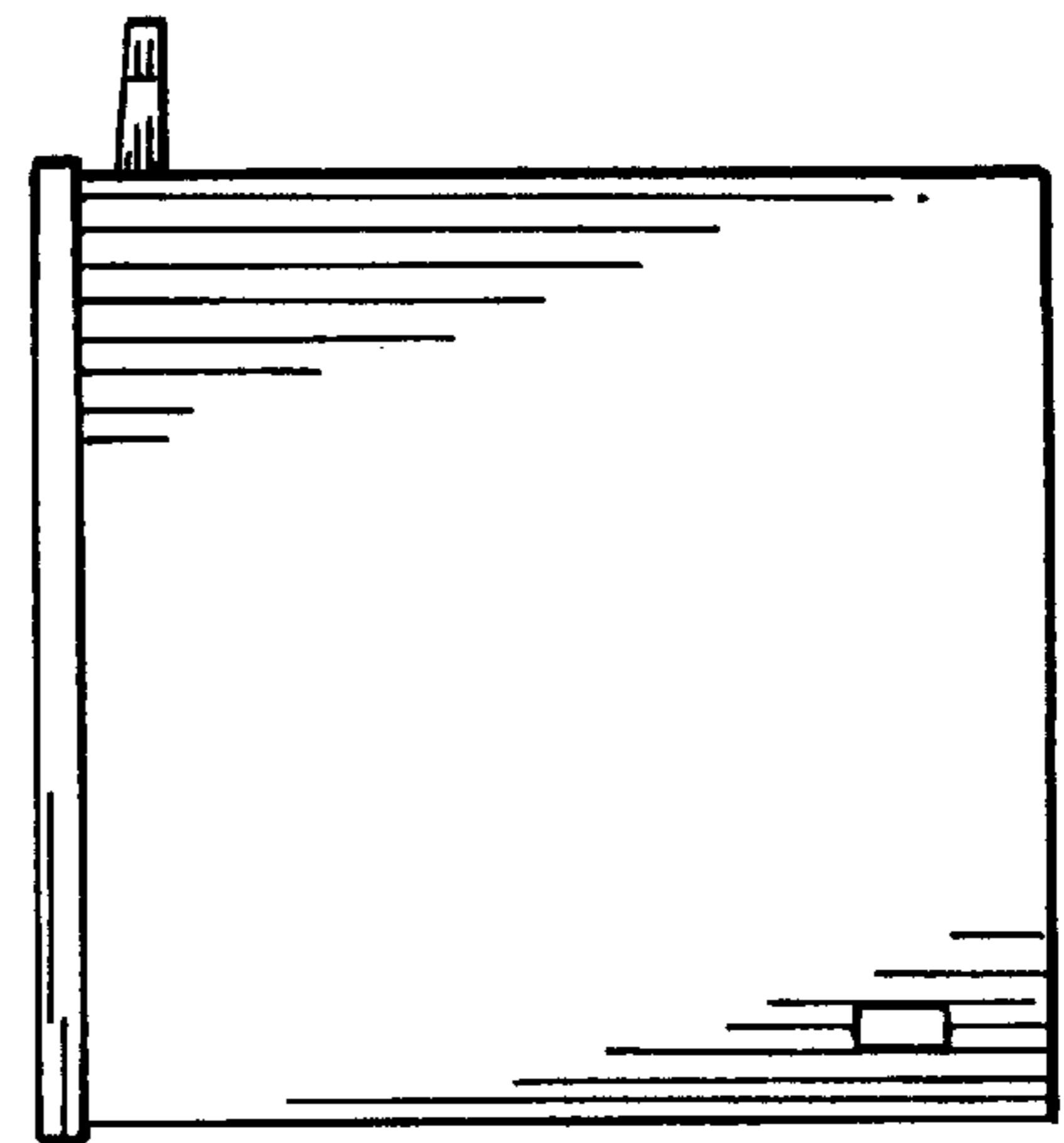

FIG. 12

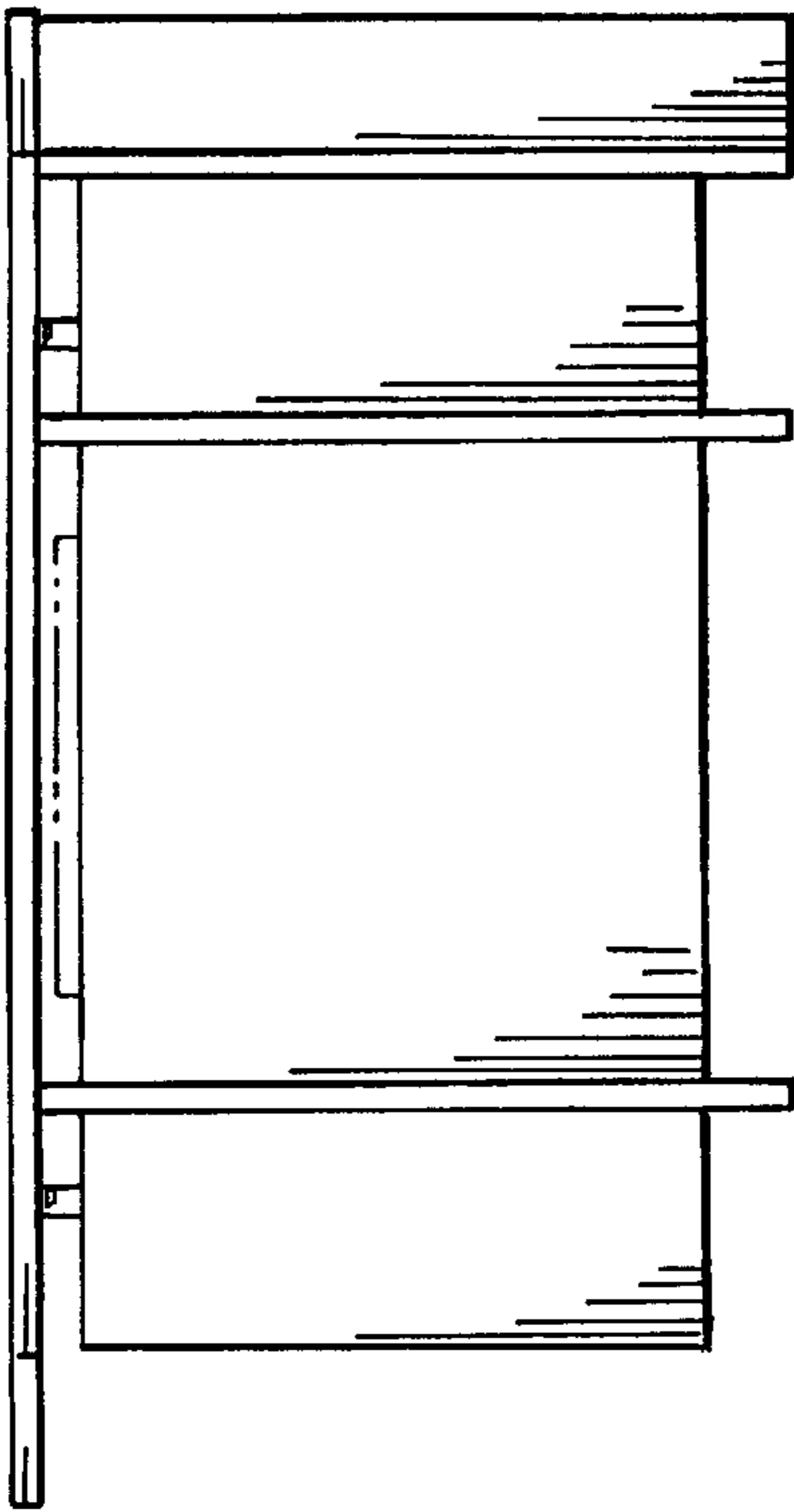

FIG. 13

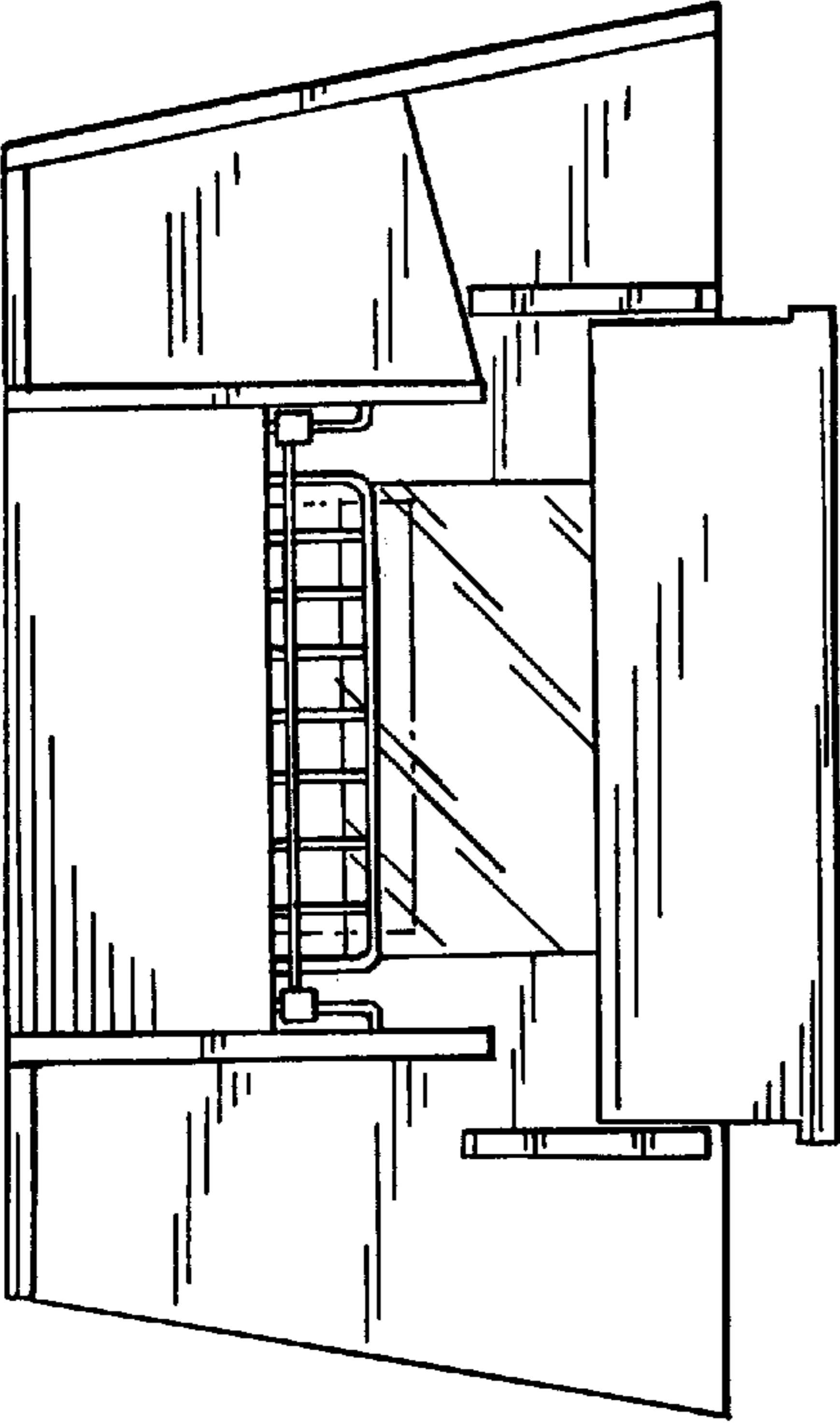

FIG. 14

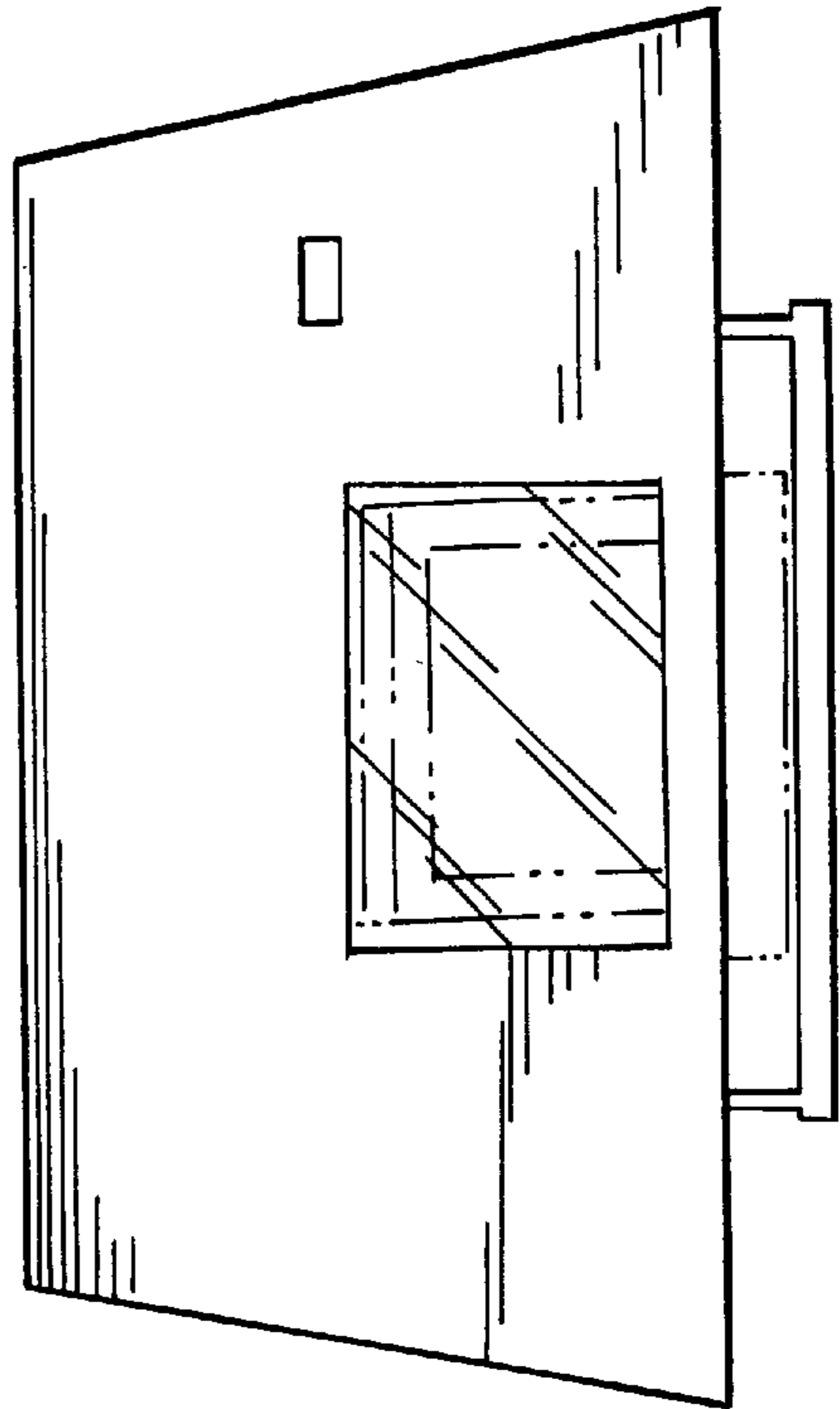

FIG. 15

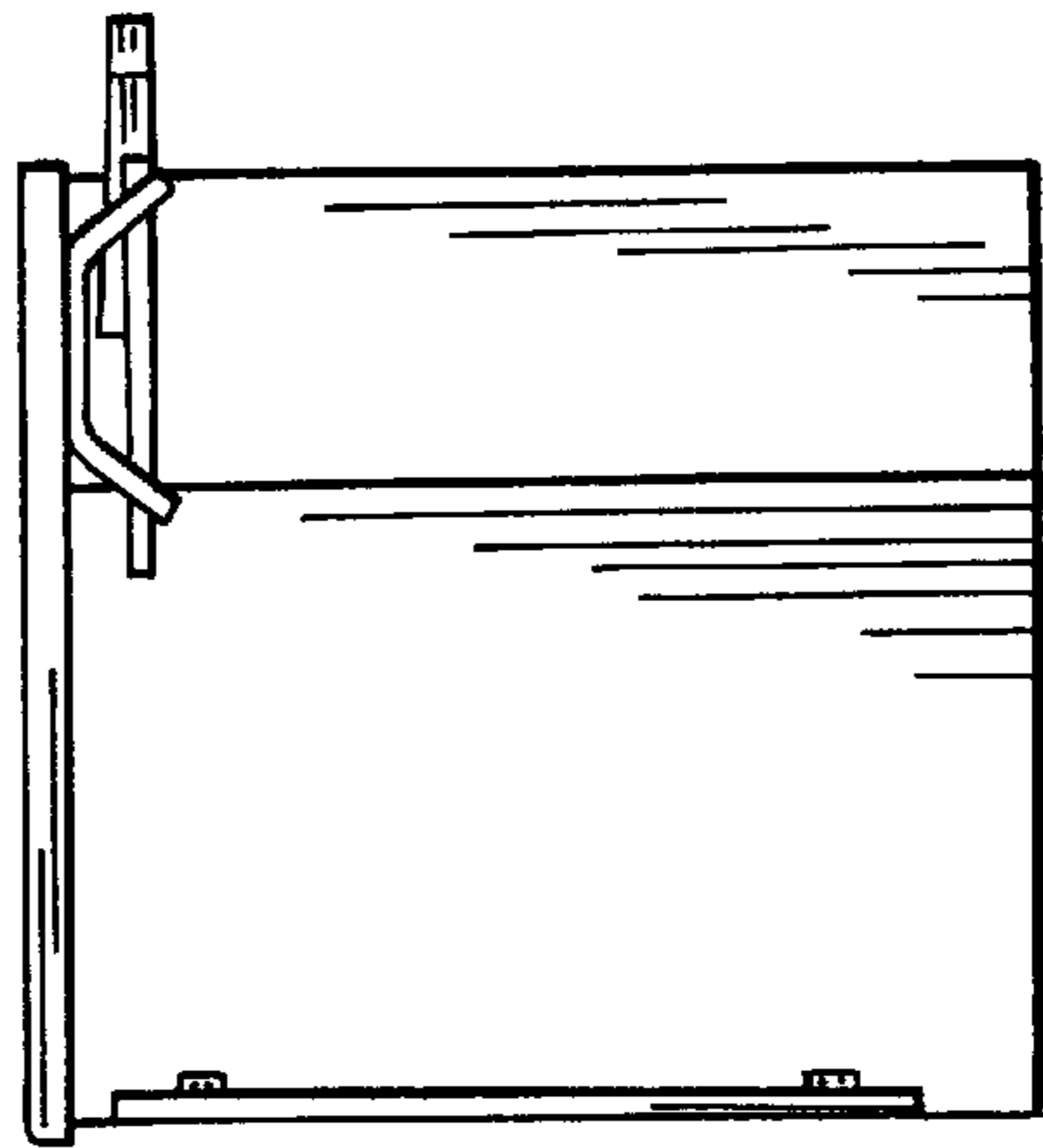

FIG. 16

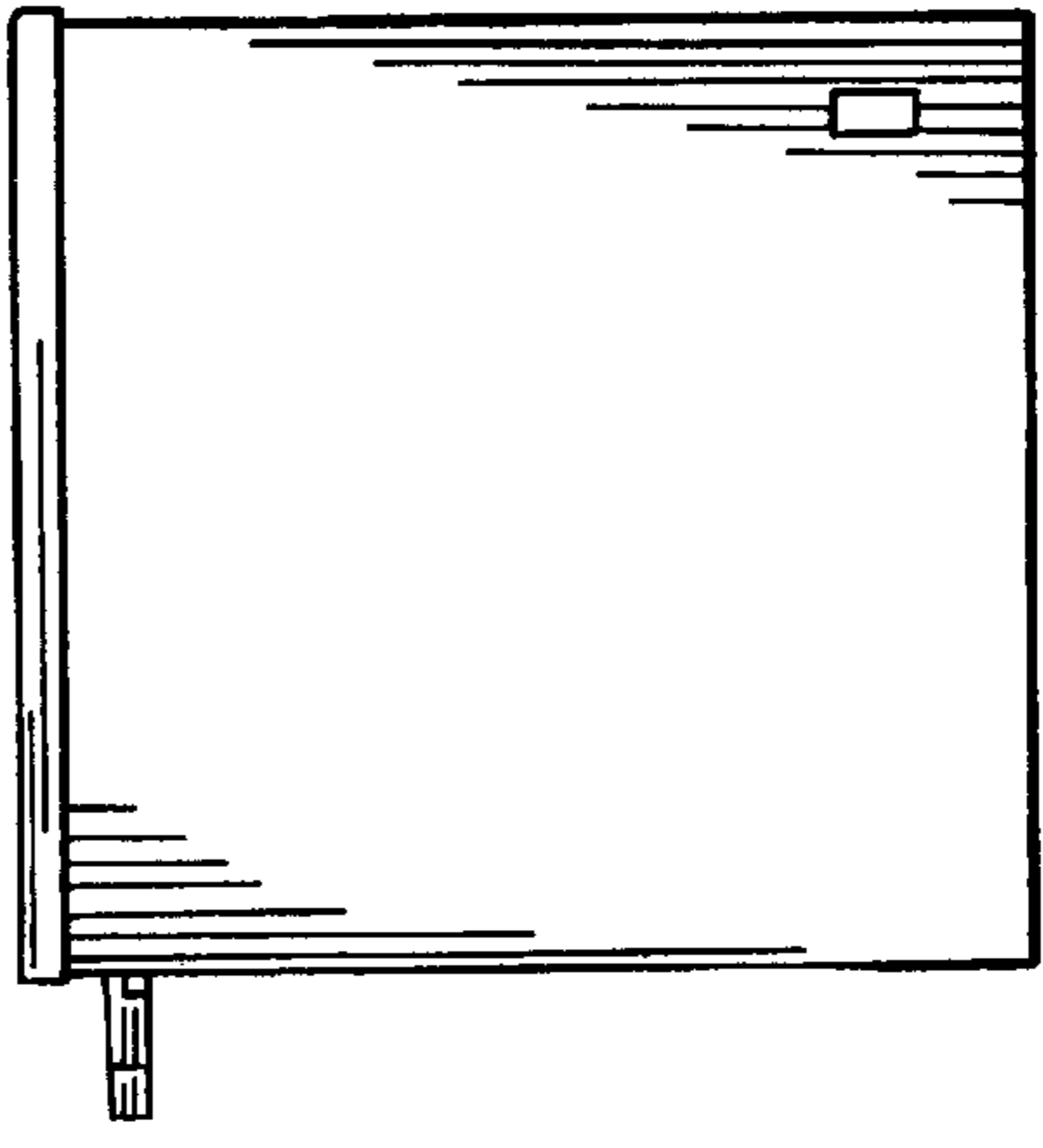

FIG. 18

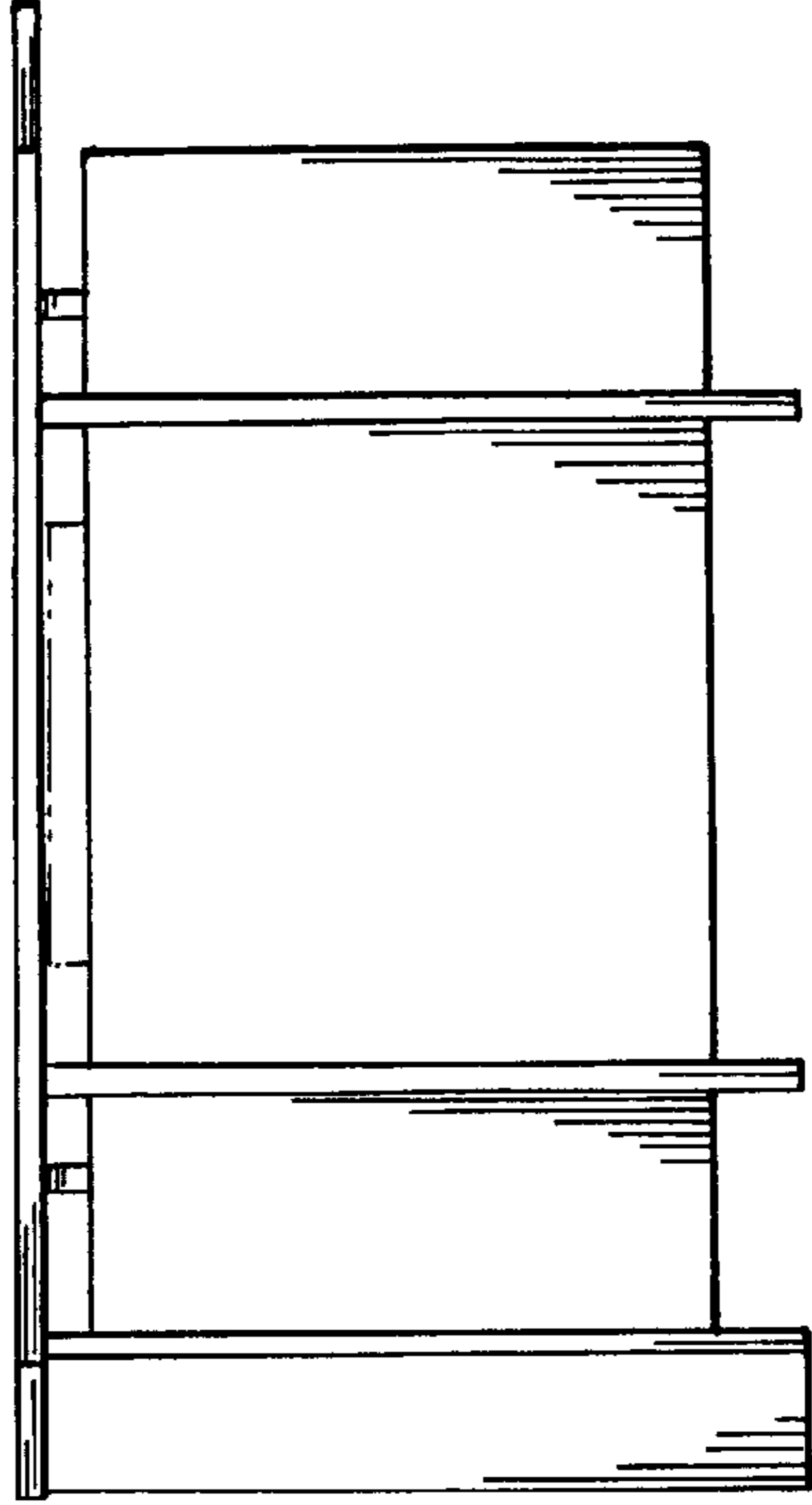

FIG. 17

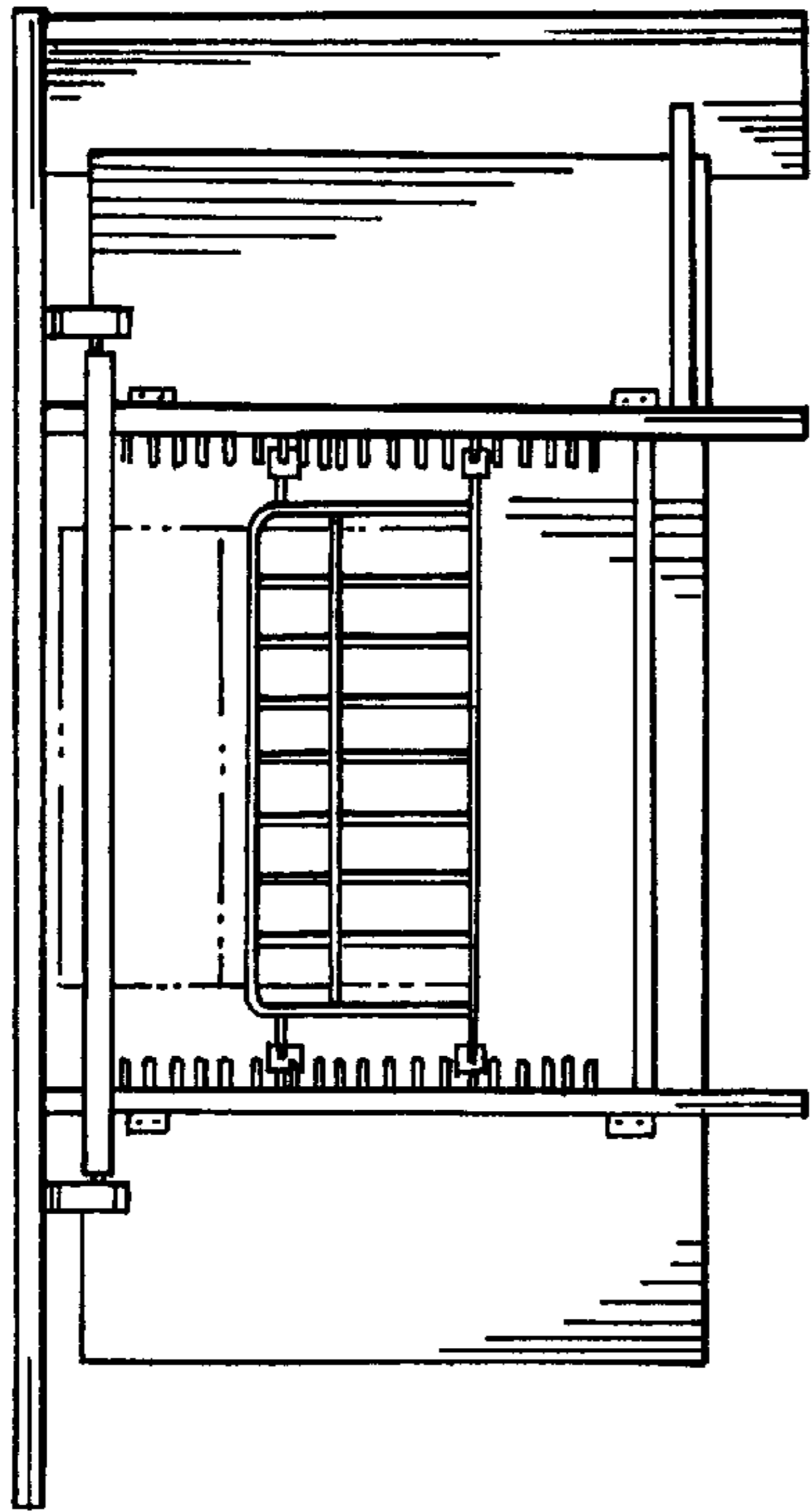

FIG. 20

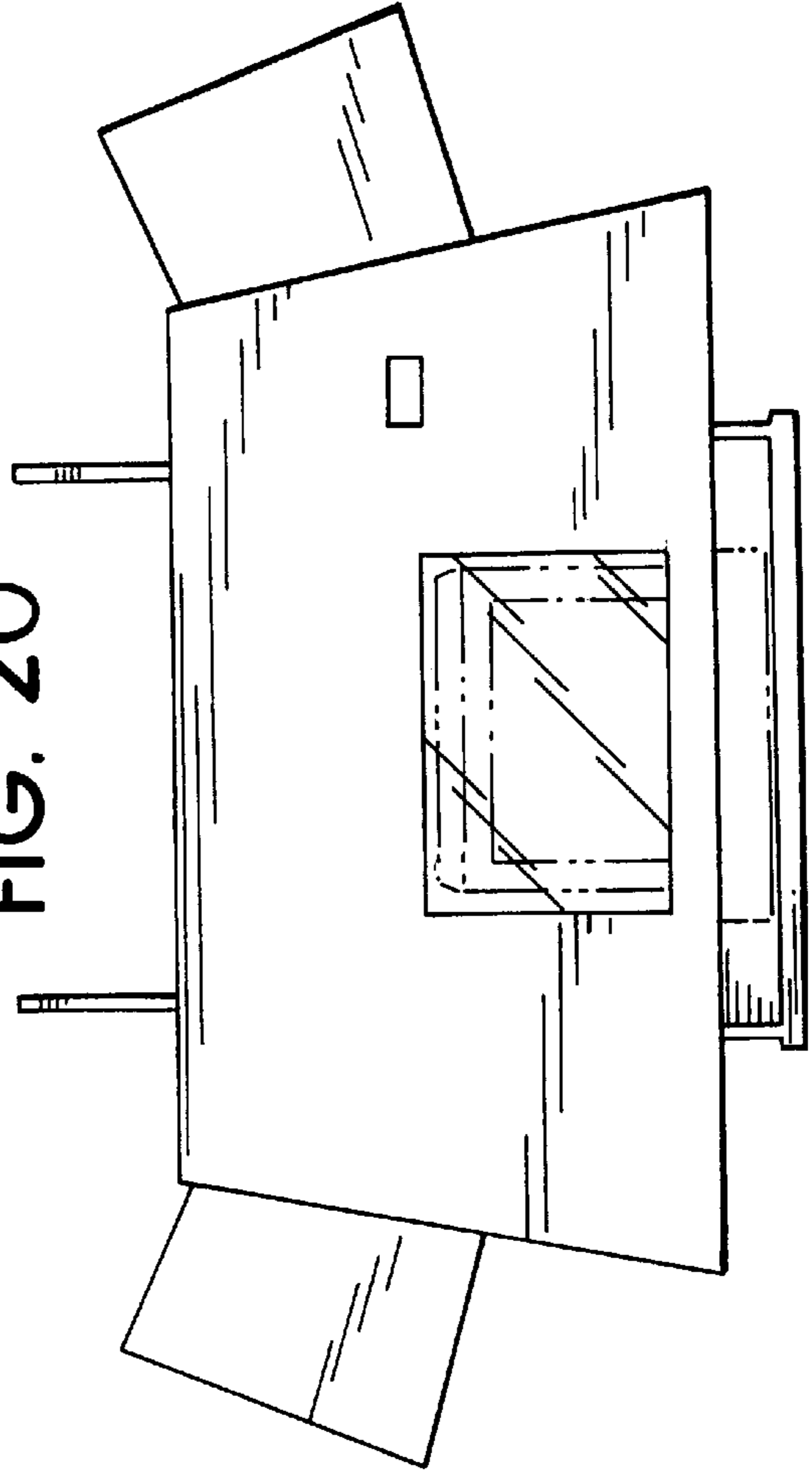

FIG. 19

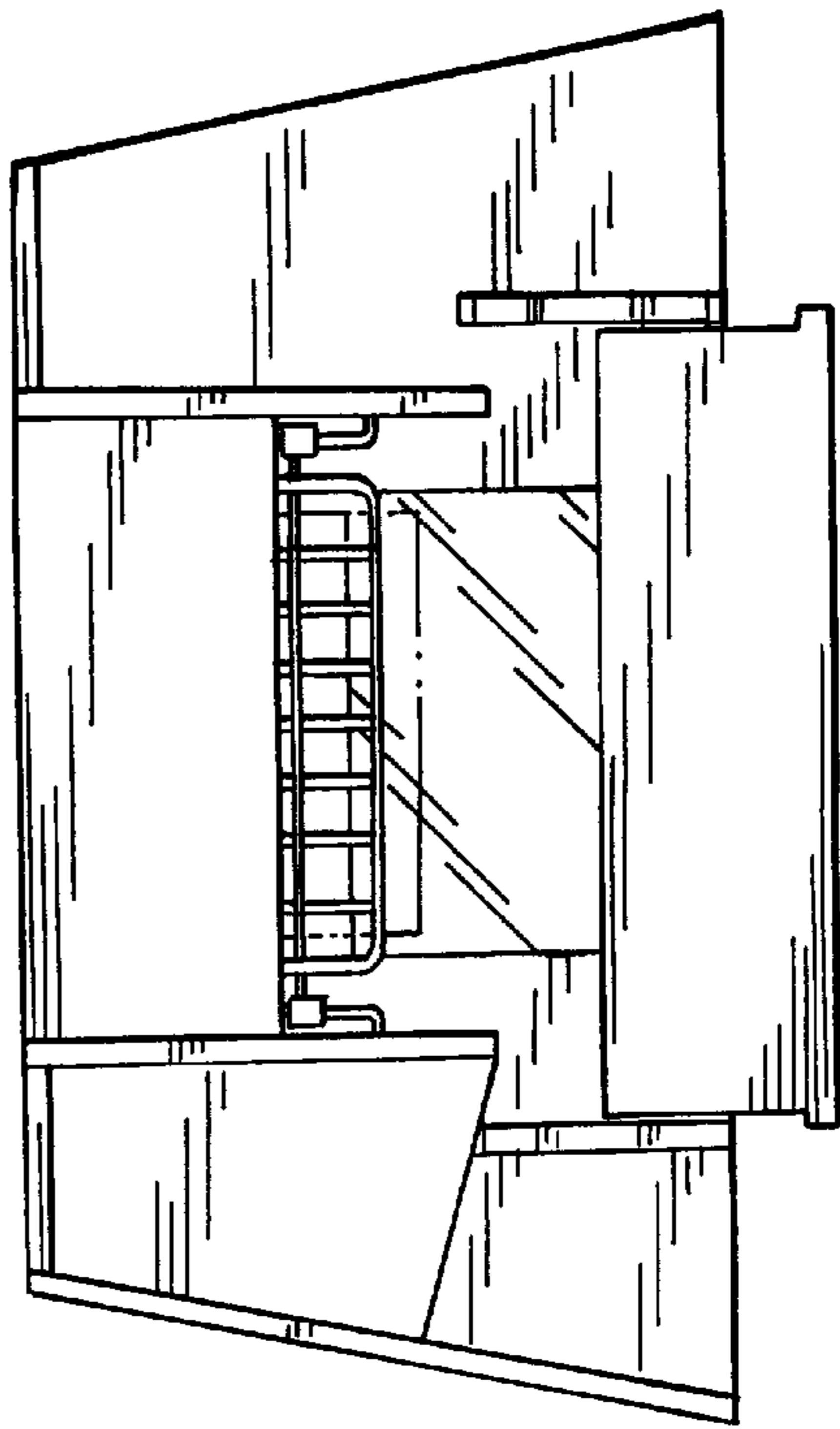

FIG. 22

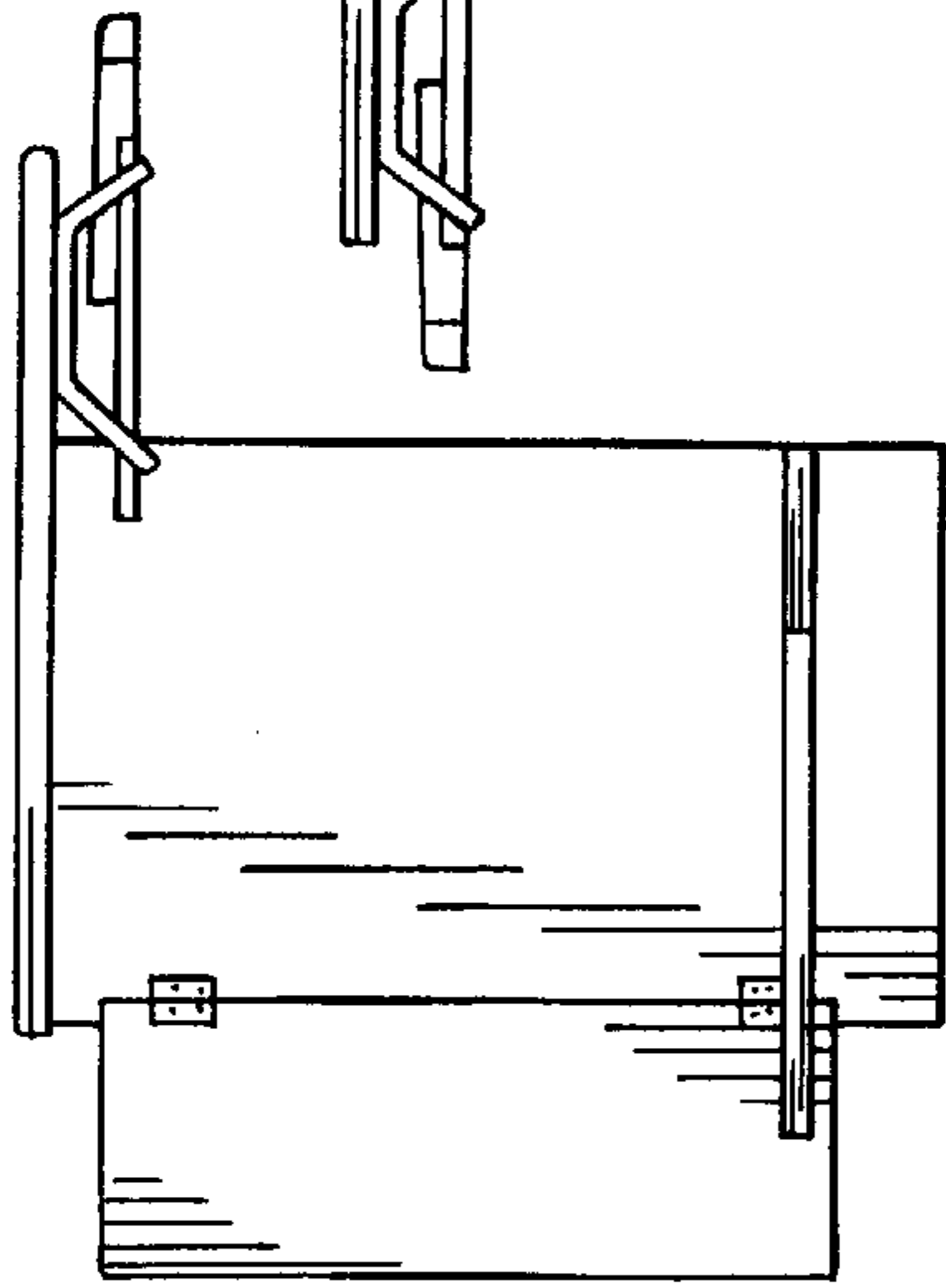

FIG. 21

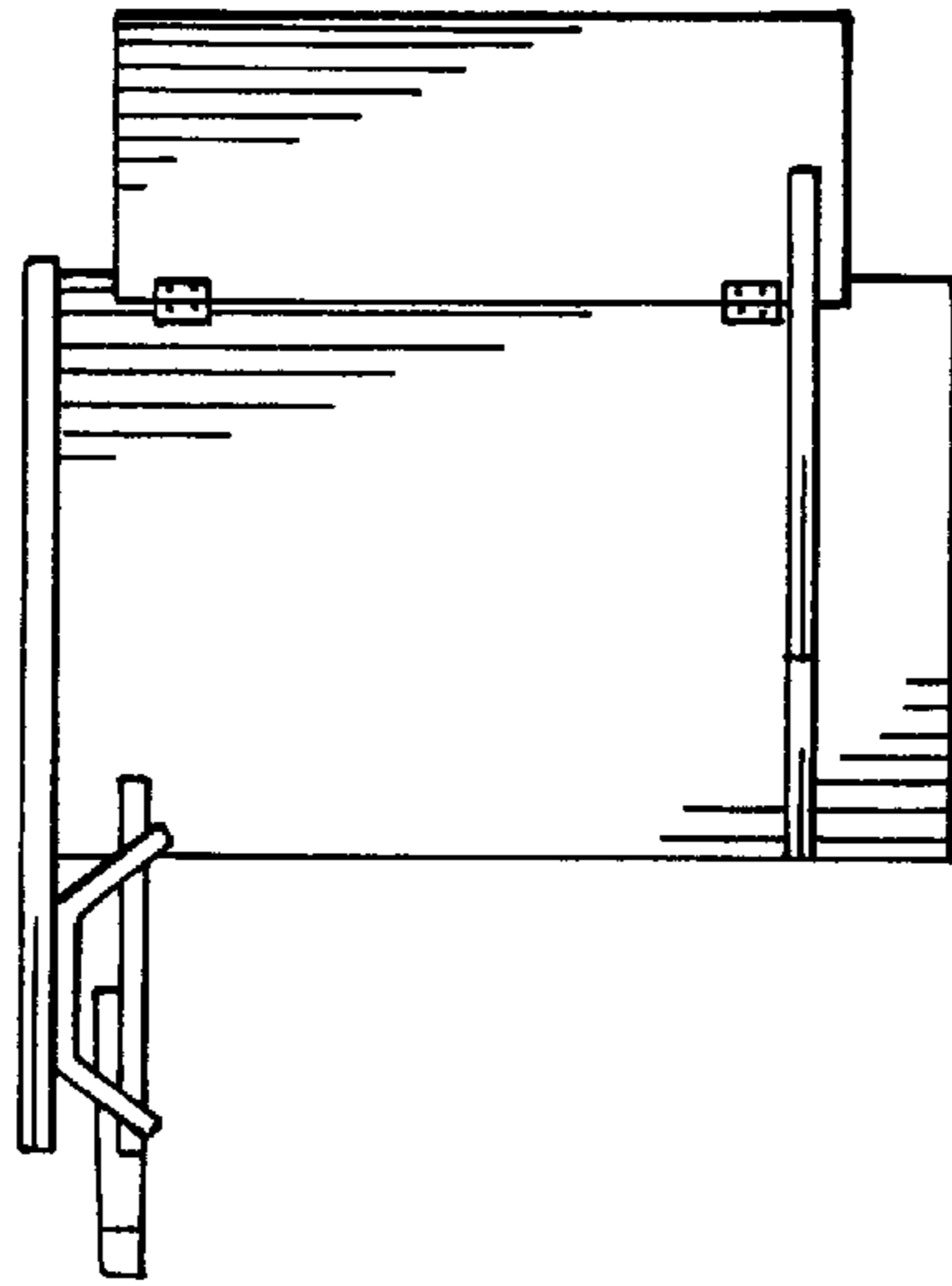

FIG. 23

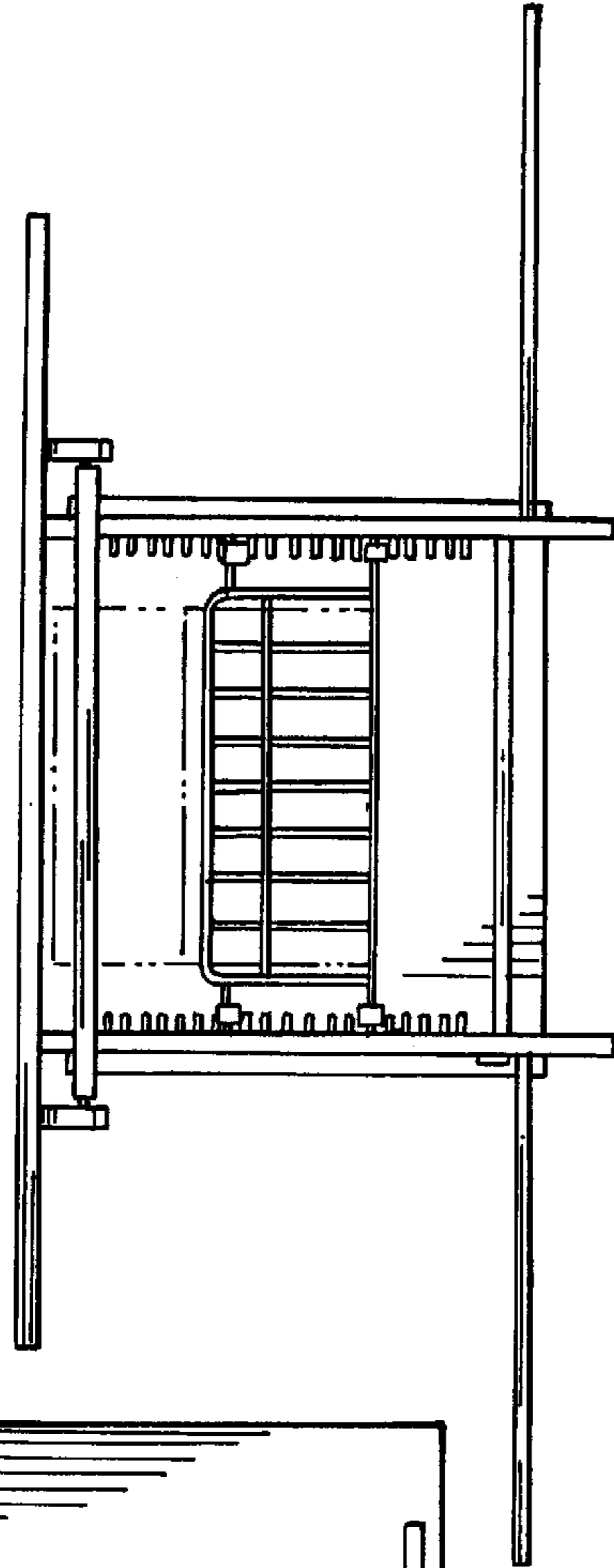

FIG. 24

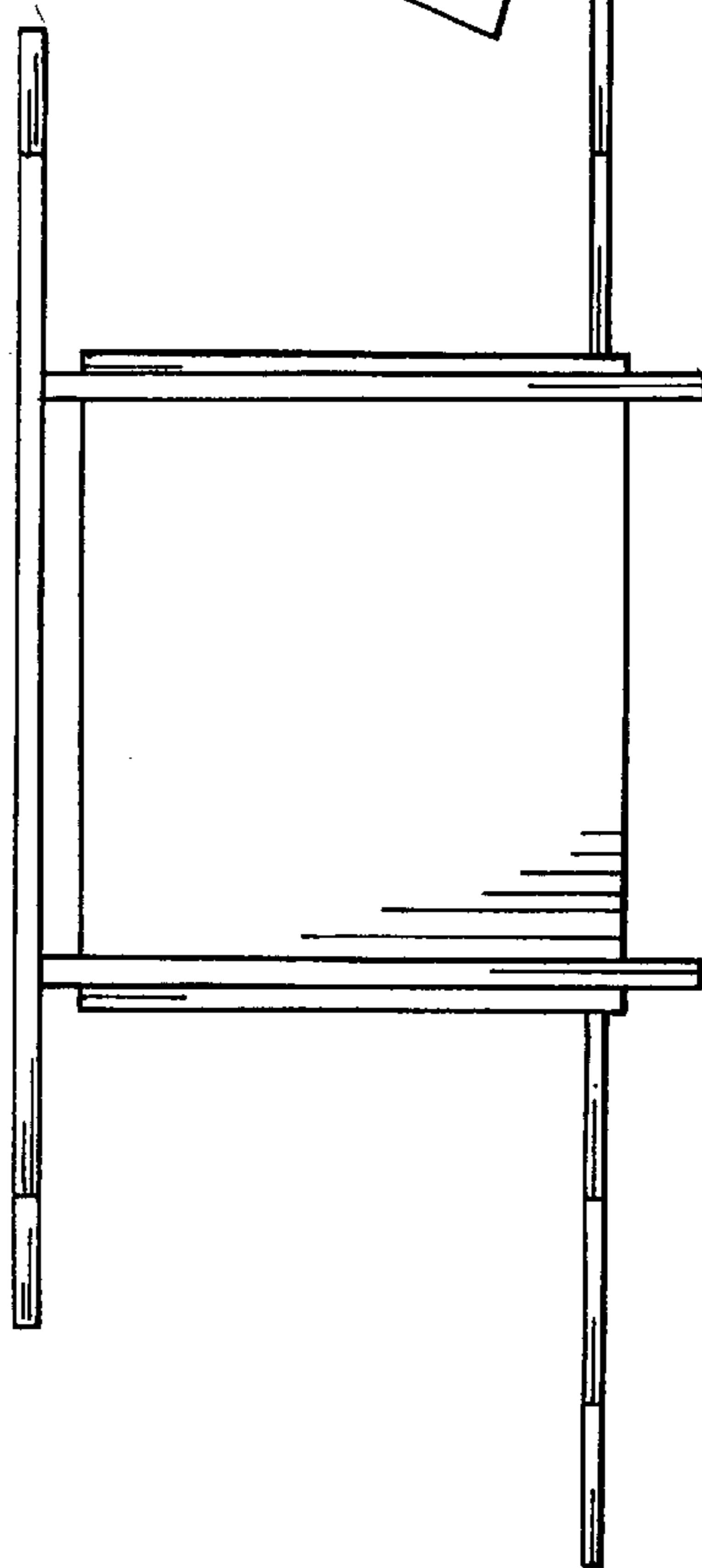
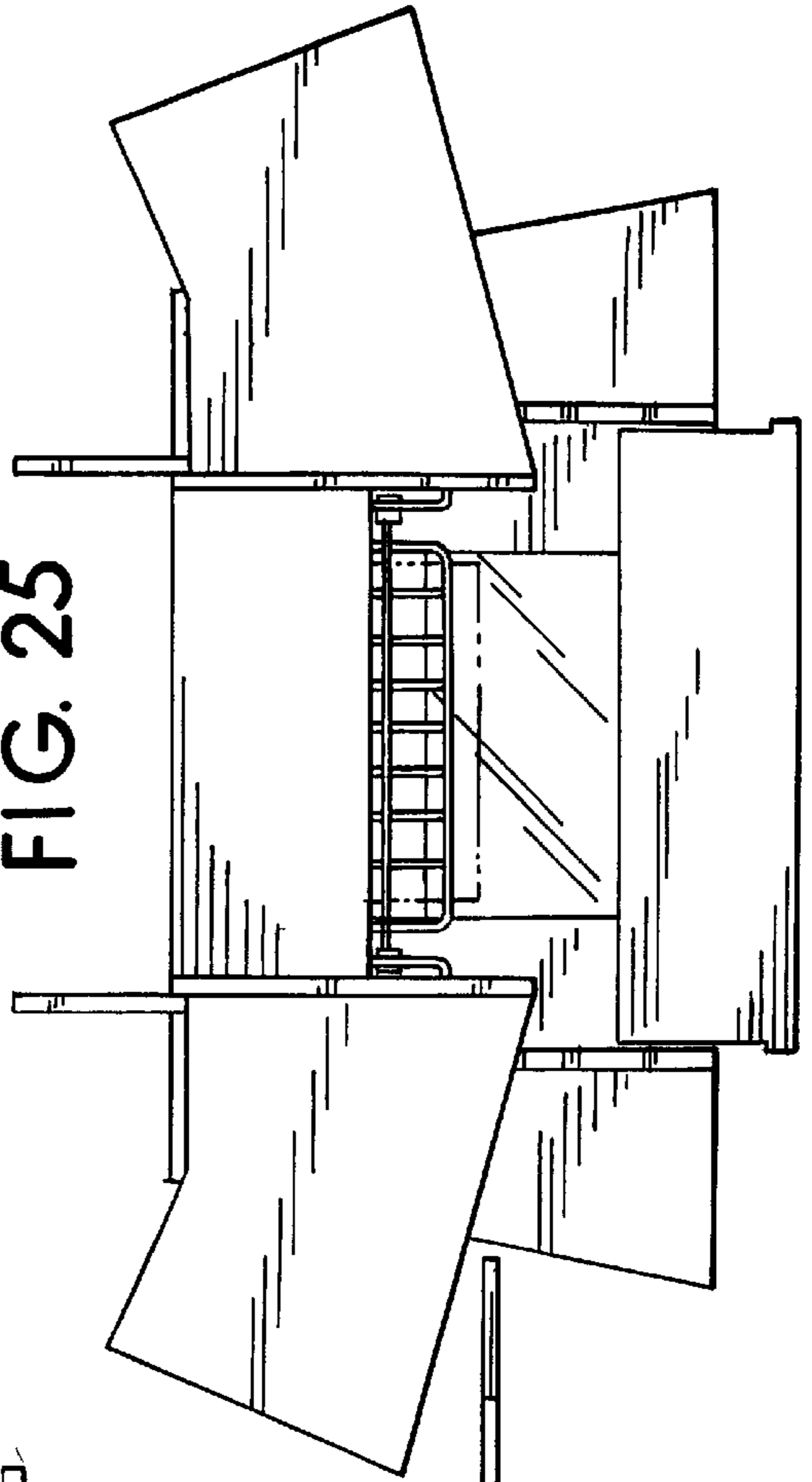
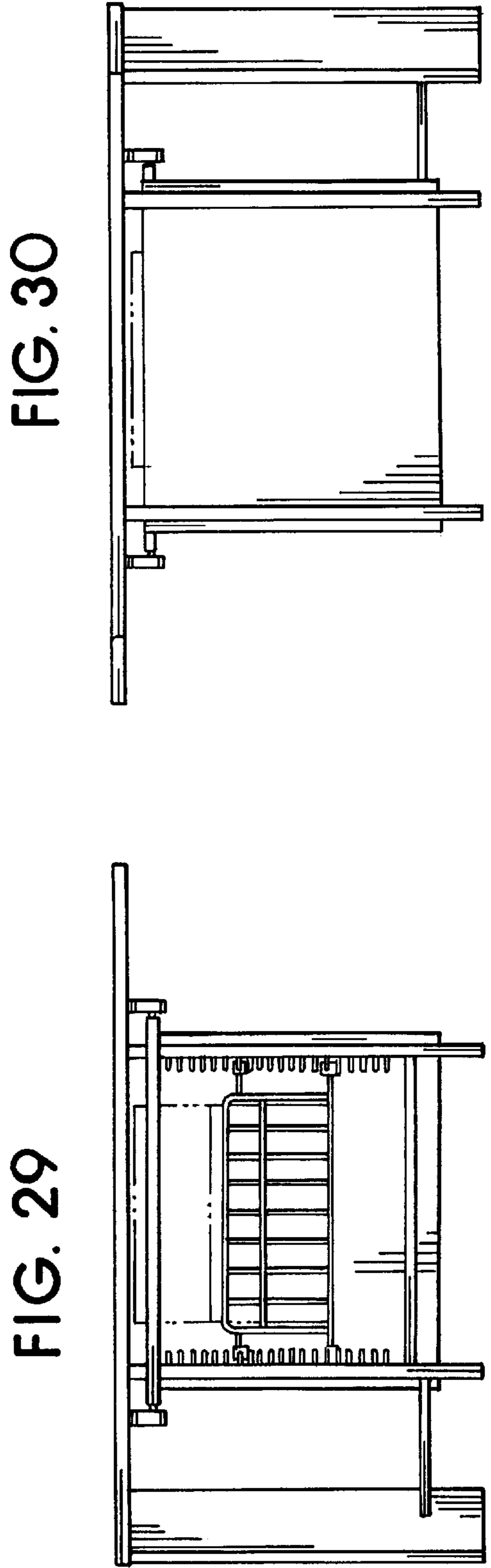
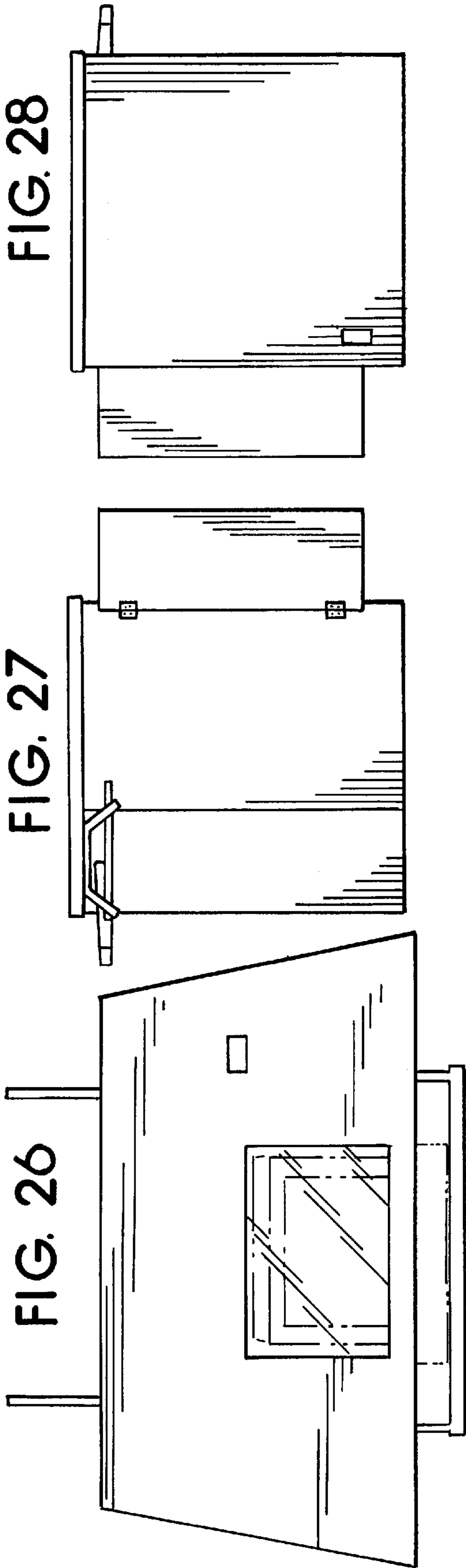

FIG. 25





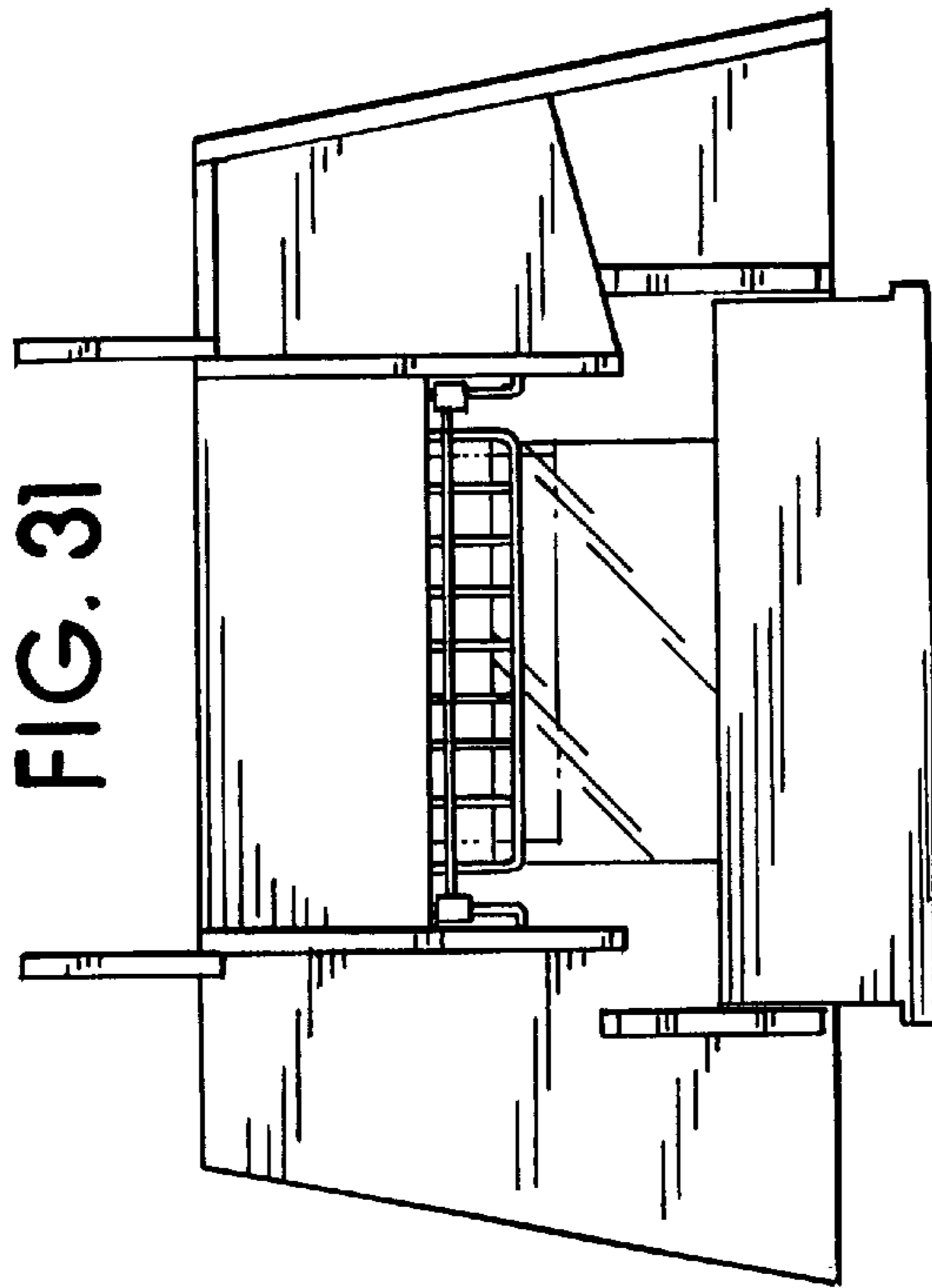
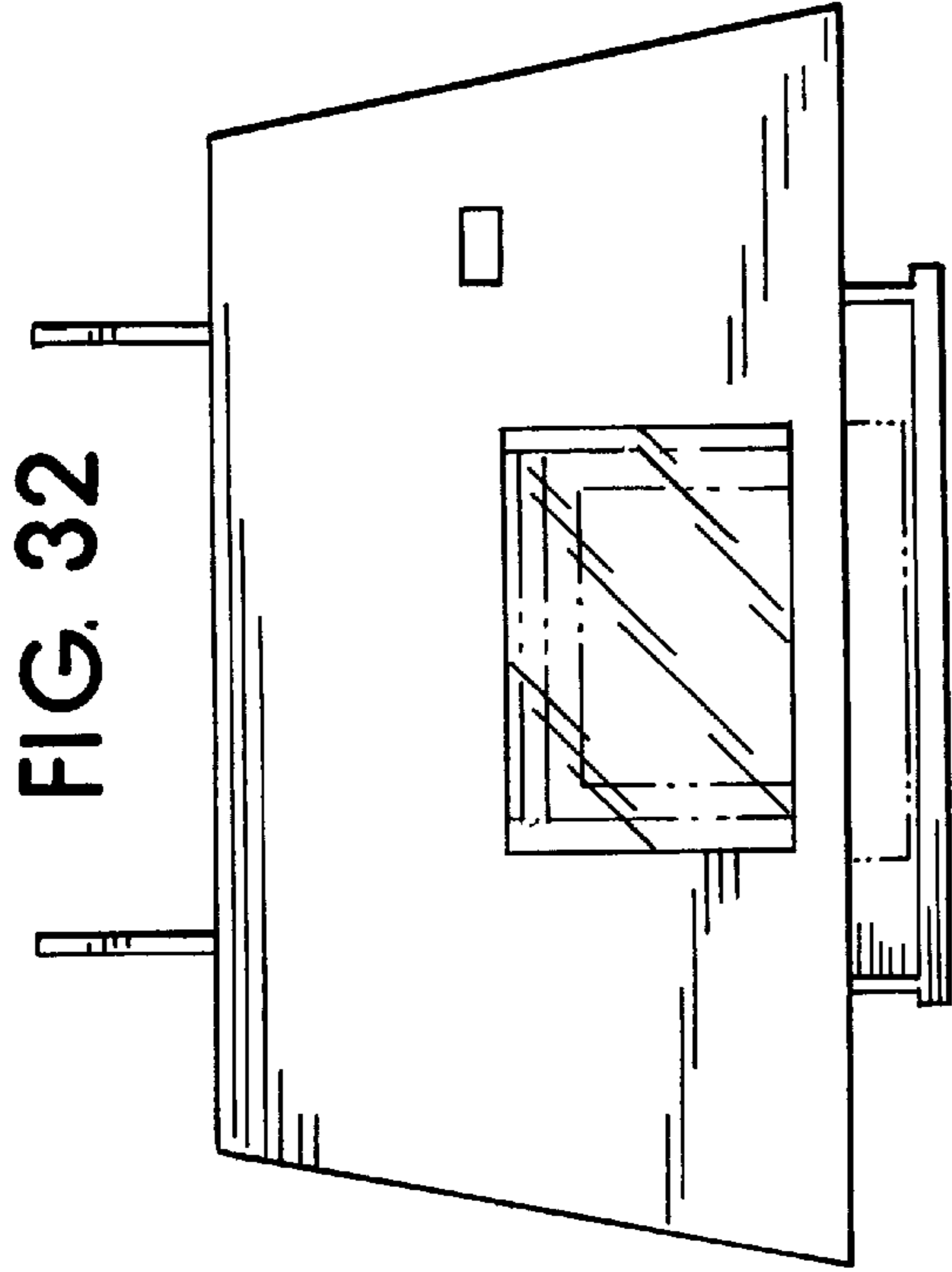

FIG. 35

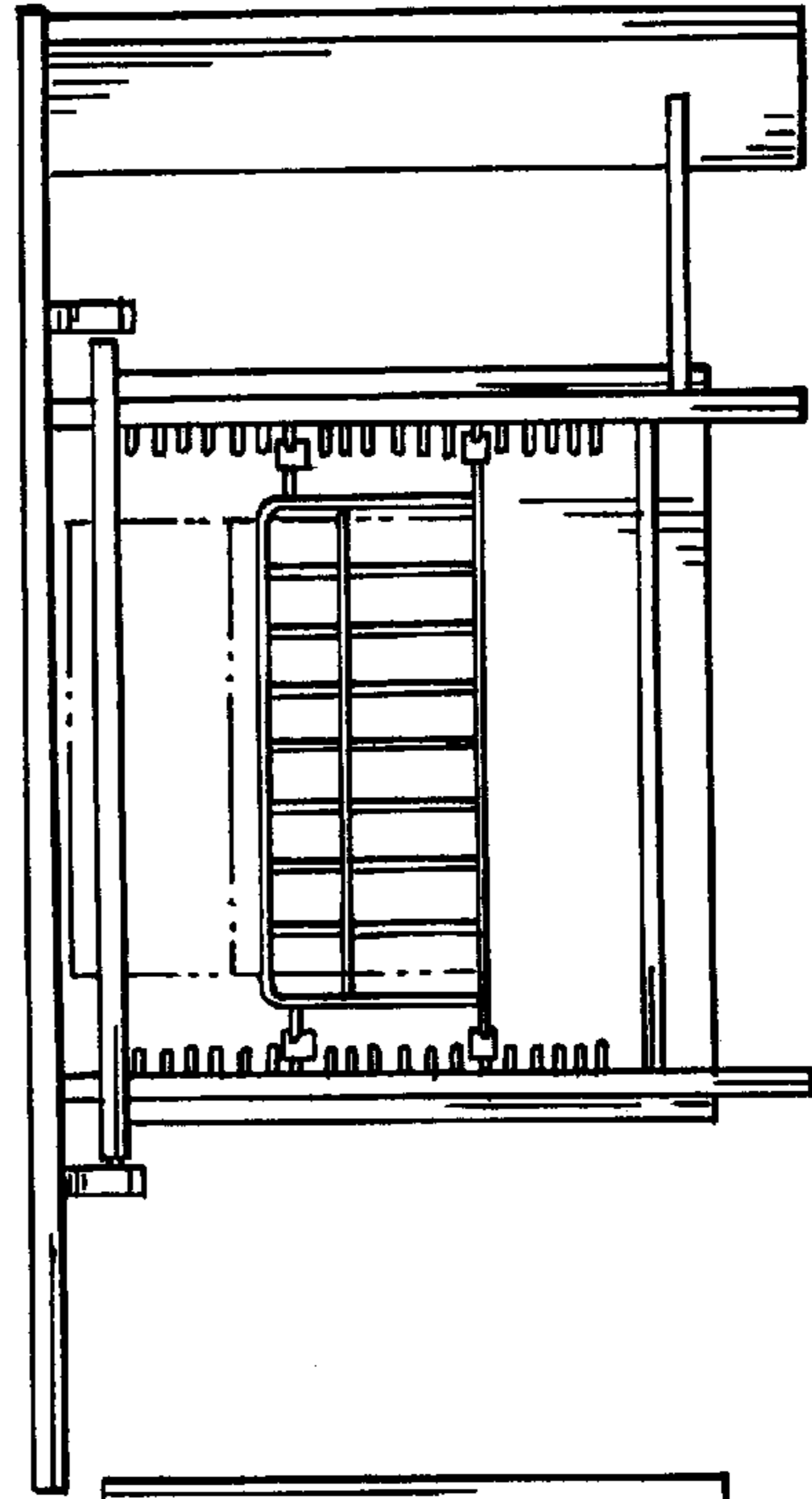

FIG. 34

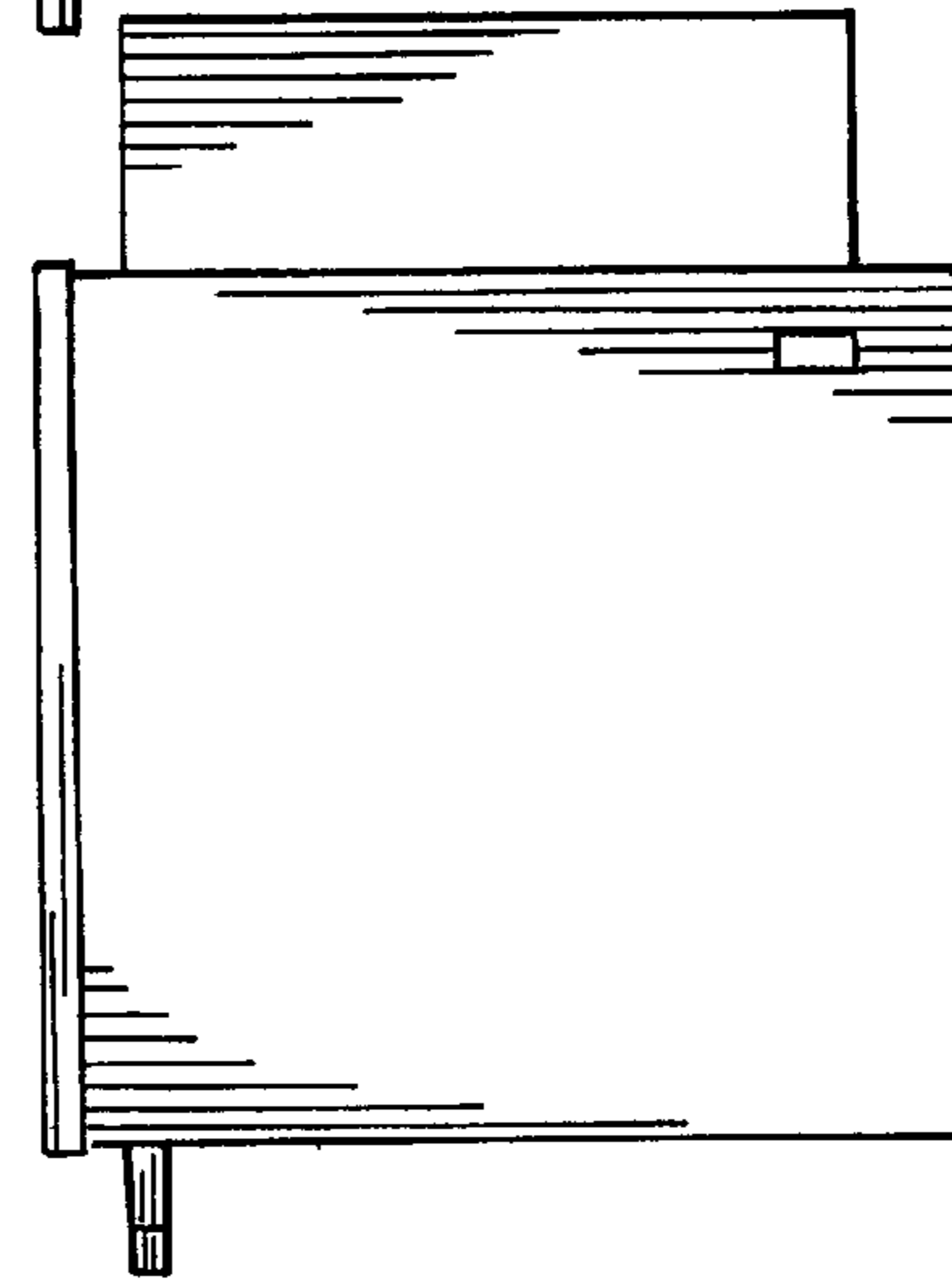

FIG. 33

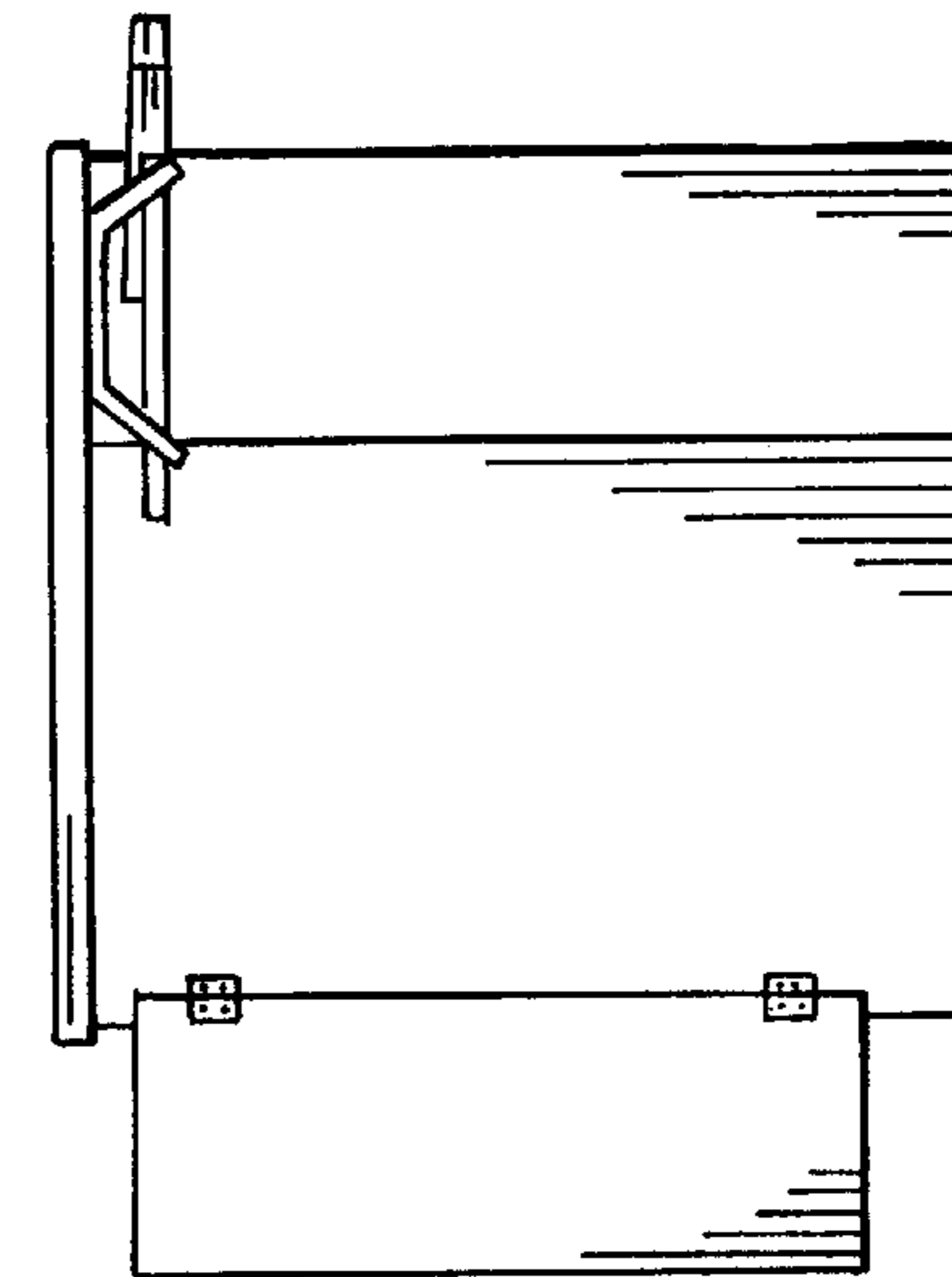

FIG. 36

