



US00D428978S

United States Patent [19]

Ito et al.

[11] **Patent Number: Des. 428,978**

[45] **Date of Patent: ** Aug. 1, 2000**

[54] **COMPRESSOR FOR A VEHICLE AIR CONDITIONER**

4,505,649 3/1985 Masuda et al. .
4,526,524 7/1985 Kondo et al. .

[75] Inventors: **Koichi Ito; Tomoji Tarutani; Yasunori Ueda; Rieko Harada; Kiyomi Okuda**, all of Kariya; **Hironobu Takeda**, Nissin; **Satoko Yokoyama**, Kariya, all of Japan

Primary Examiner—Lisa Lichtenstein
Attorney, Agent, or Firm—Morgan & Finnegan, L.L.P.

[73] Assignee: **Kabushiki Kaisha Toyoda Jidoshokki Seisakusho**, Kariya, Japan

[57] **CLAIM**

The ornamental design for a compressor for a vehicle air conditioner, as shown and described.

[**] Term: **14 Years**

DESCRIPTION

[21] Appl. No.: **29/099,608**

FIG. 1 is a front elevational view of a compressor for a vehicle air conditioner showing our new design;

[22] Filed: **Jan. 25, 1999**

FIG. 2 is a rear elevational view thereof;

Related U.S. Application Data

[62] Division of application No. 29/062,161, Nov. 8, 1996, Pat. No. Des. 417,266.

FIG. 3 is a top plan view thereof;

FIG. 4 is a bottom plan view thereof;

[30] **Foreign Application Priority Data**

May 9, 1996 [JP] Japan 8-013755
Jun. 6, 1996 [JP] Japan 8-016840

FIG. 5 is a left side elevational view thereof;

FIG. 6 is a right side elevational view thereof;

[51] **LOC (7) Cl.** **12-16**

[52] **U.S. Cl.** **D23/325; D23/354**

[58] **Field of Search** 418/259, 63; **D23/325, D23/354**

FIG. 7 is a perspective view thereof on a reduced scale showing a location for mounting the compressor of FIG. 1;

FIG. 8 is a front perspective view of the compressor of FIG. 1; and,

FIG. 9 is a rear perspective view thereof.

The broken-line showing of environmental structure in FIG. 7 is for illustrative purposes only and forms no part of the claimed design.

[56] **References Cited**

U.S. PATENT DOCUMENTS

D. 356,862 3/1995 Ito et al. .

1 Claim, 4 Drawing Sheets

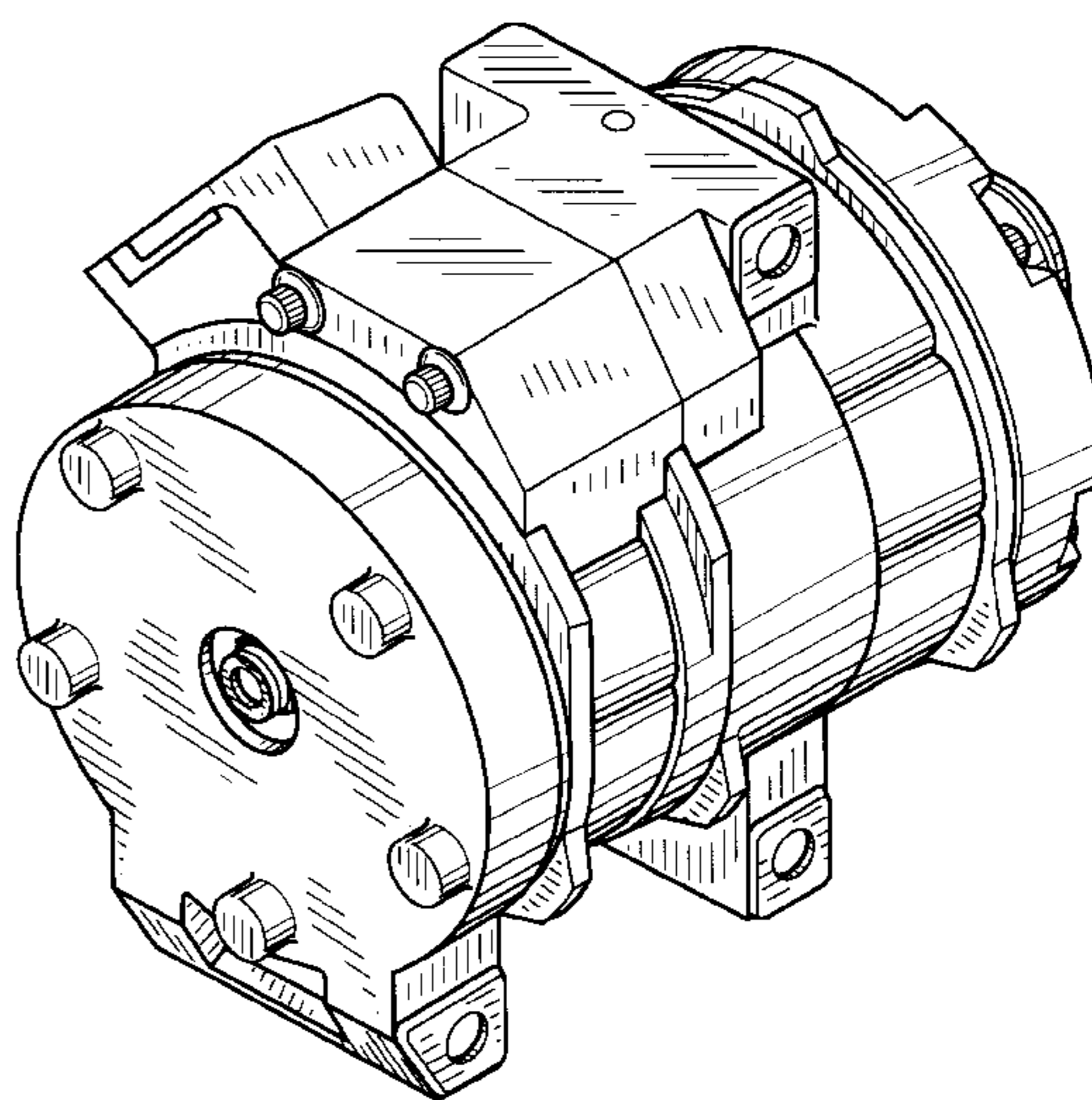
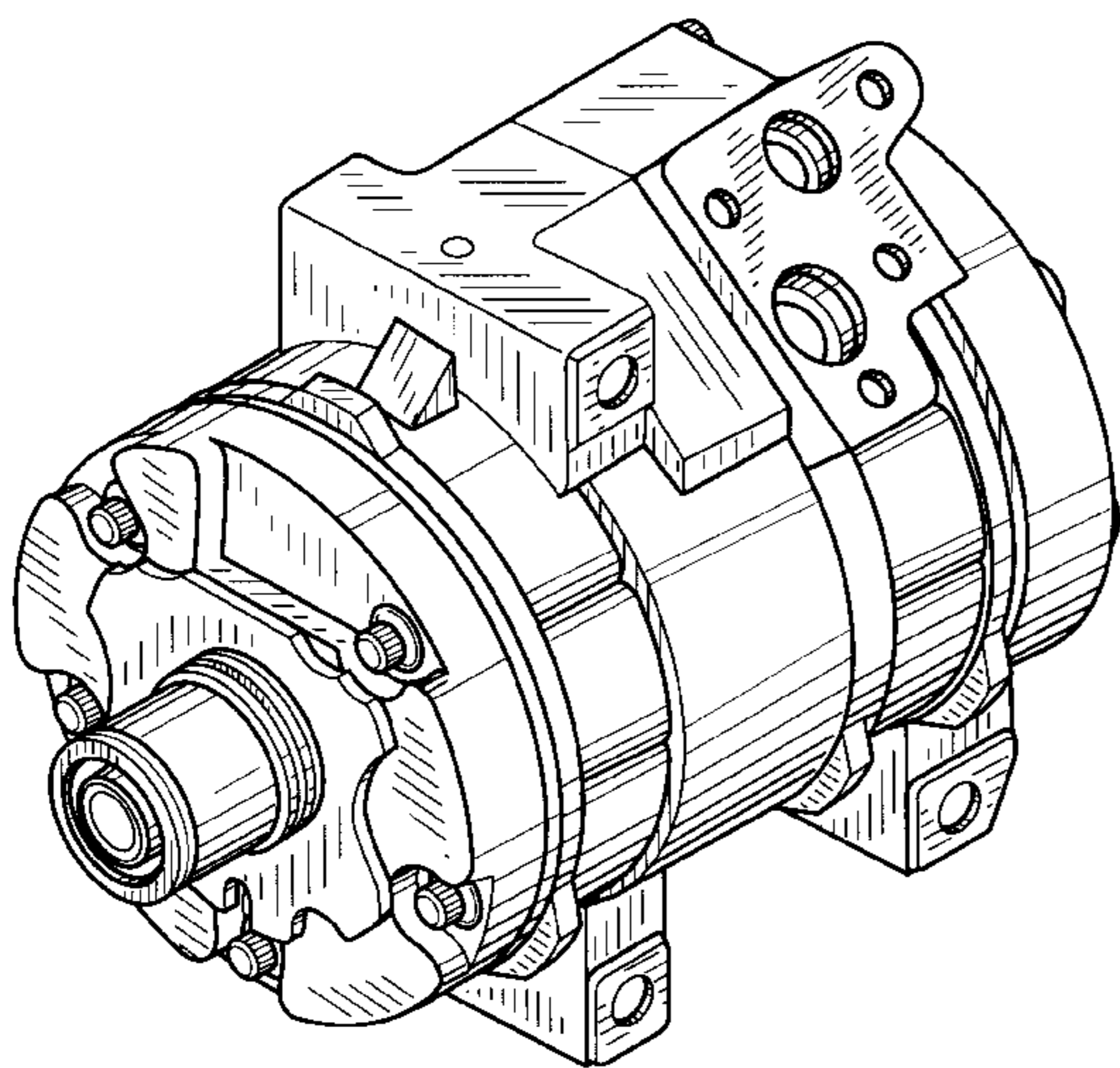

FIG. 1

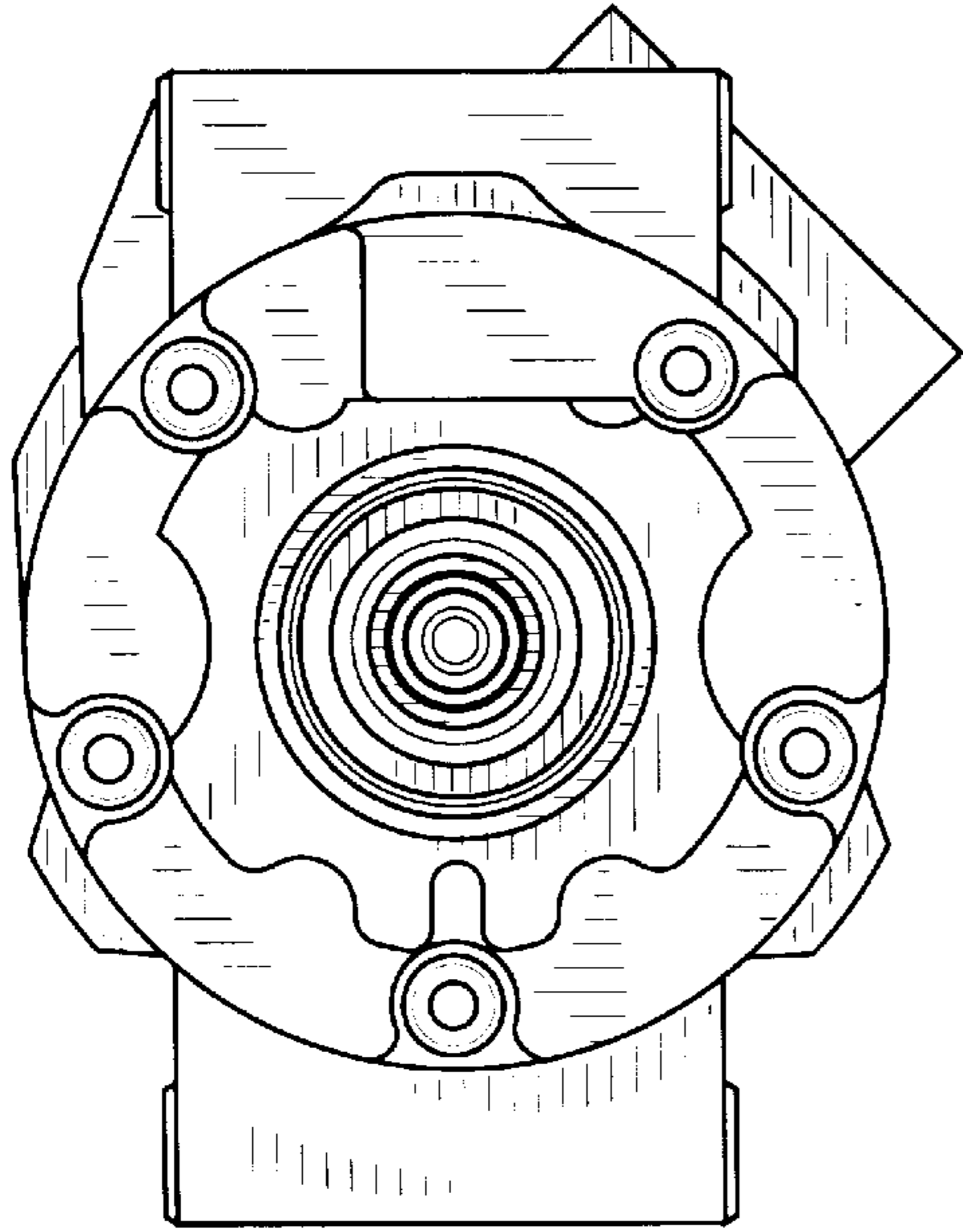

FIG. 2

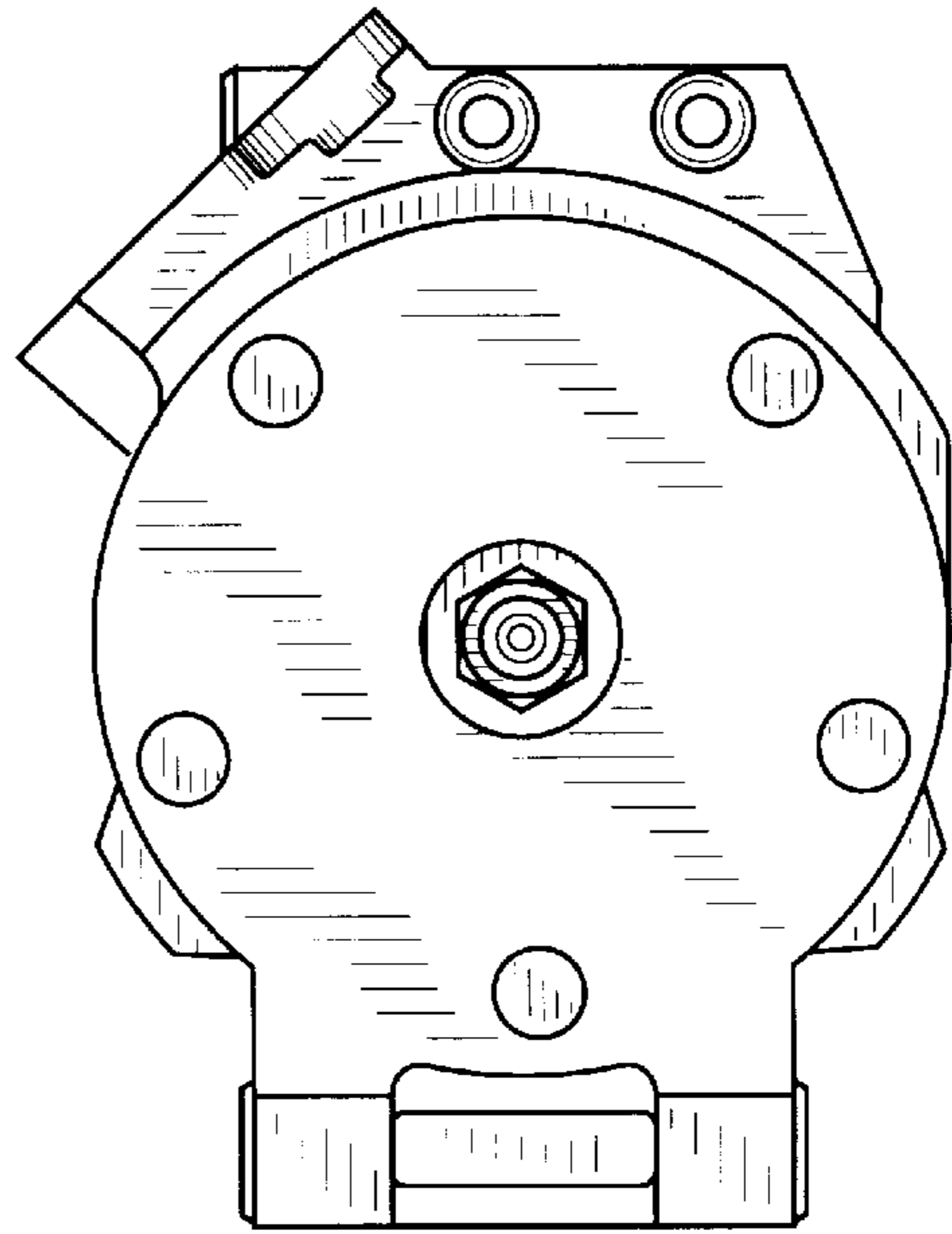

FIG. 3

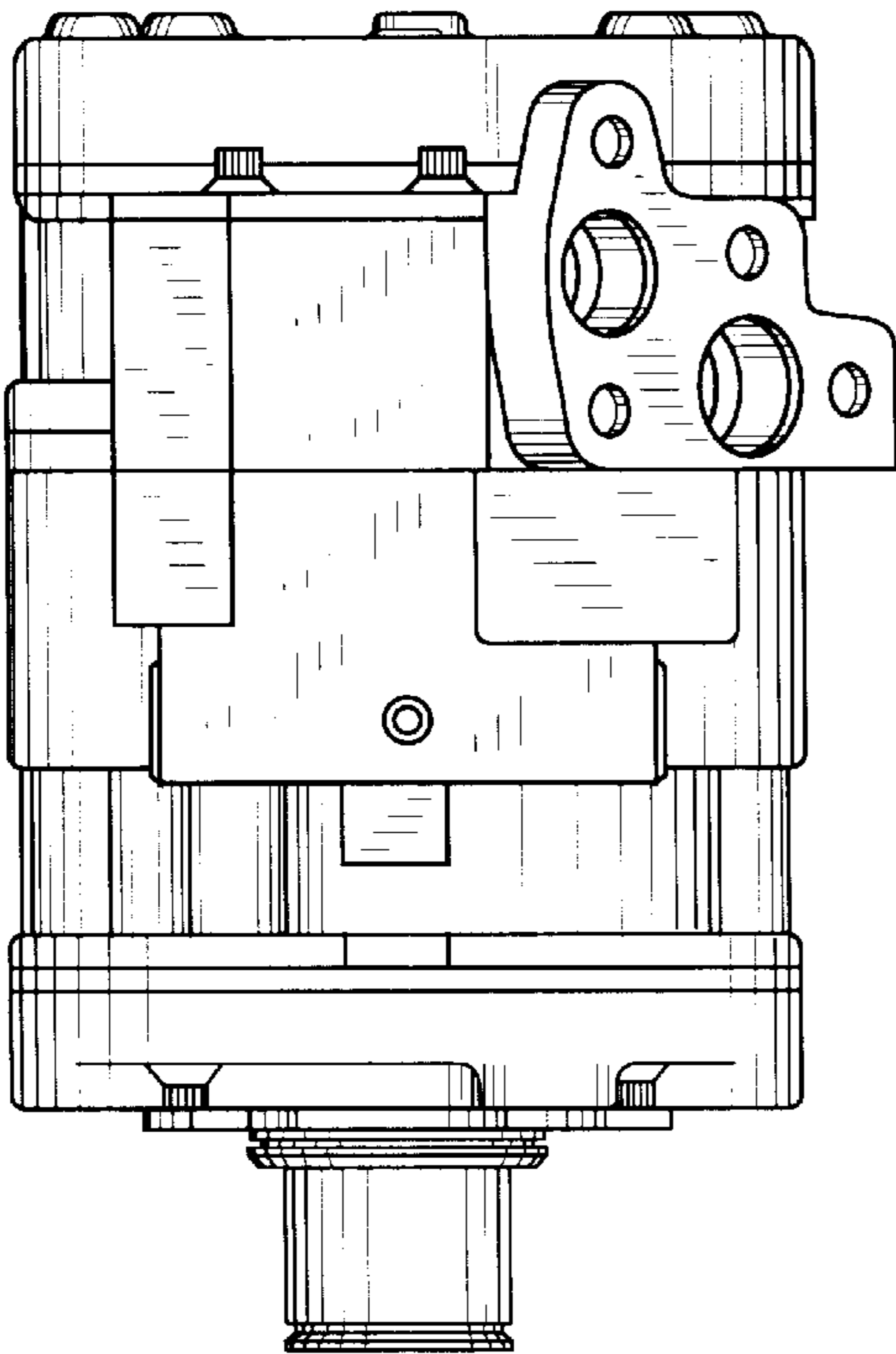

FIG. 4

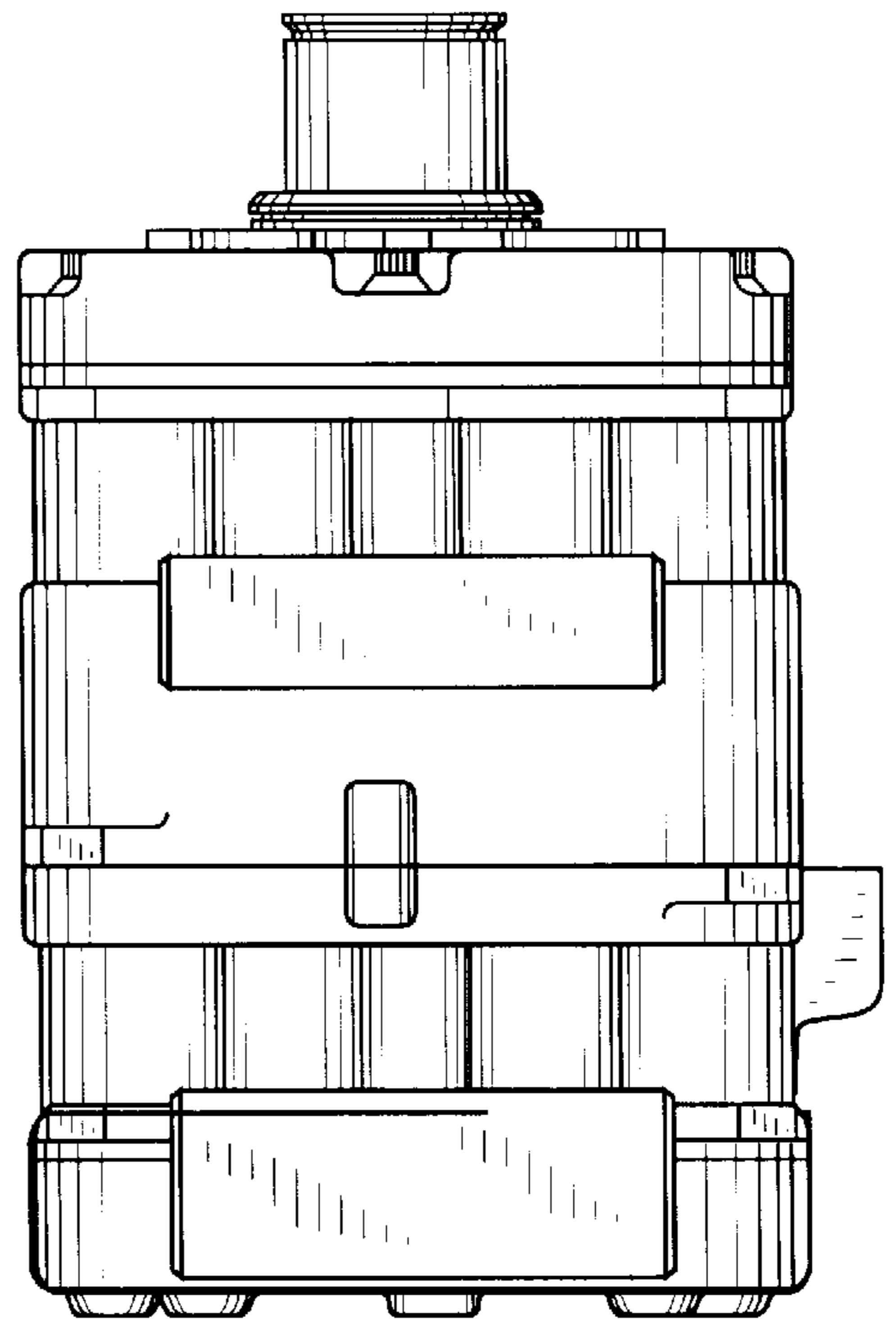

FIG. 5

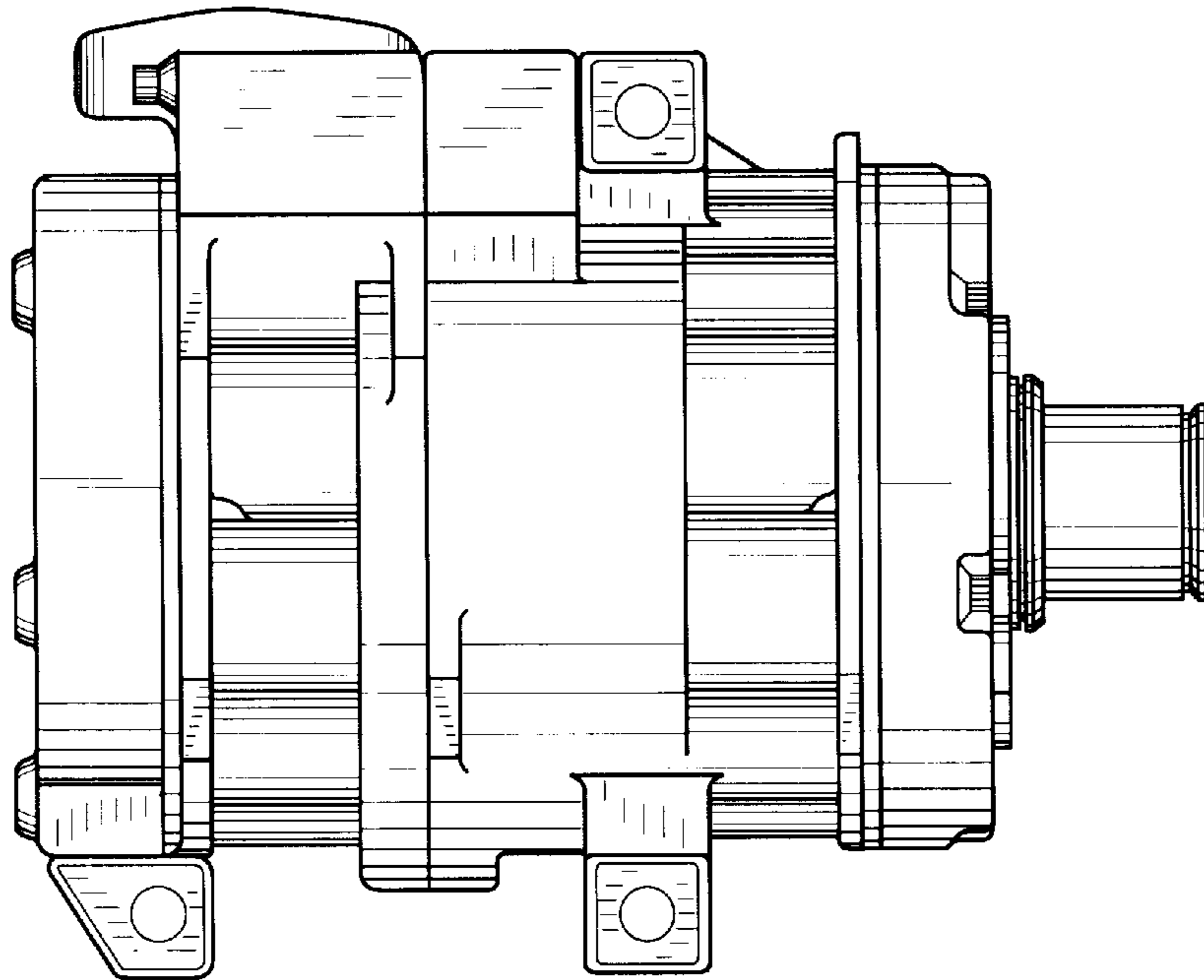

FIG. 6

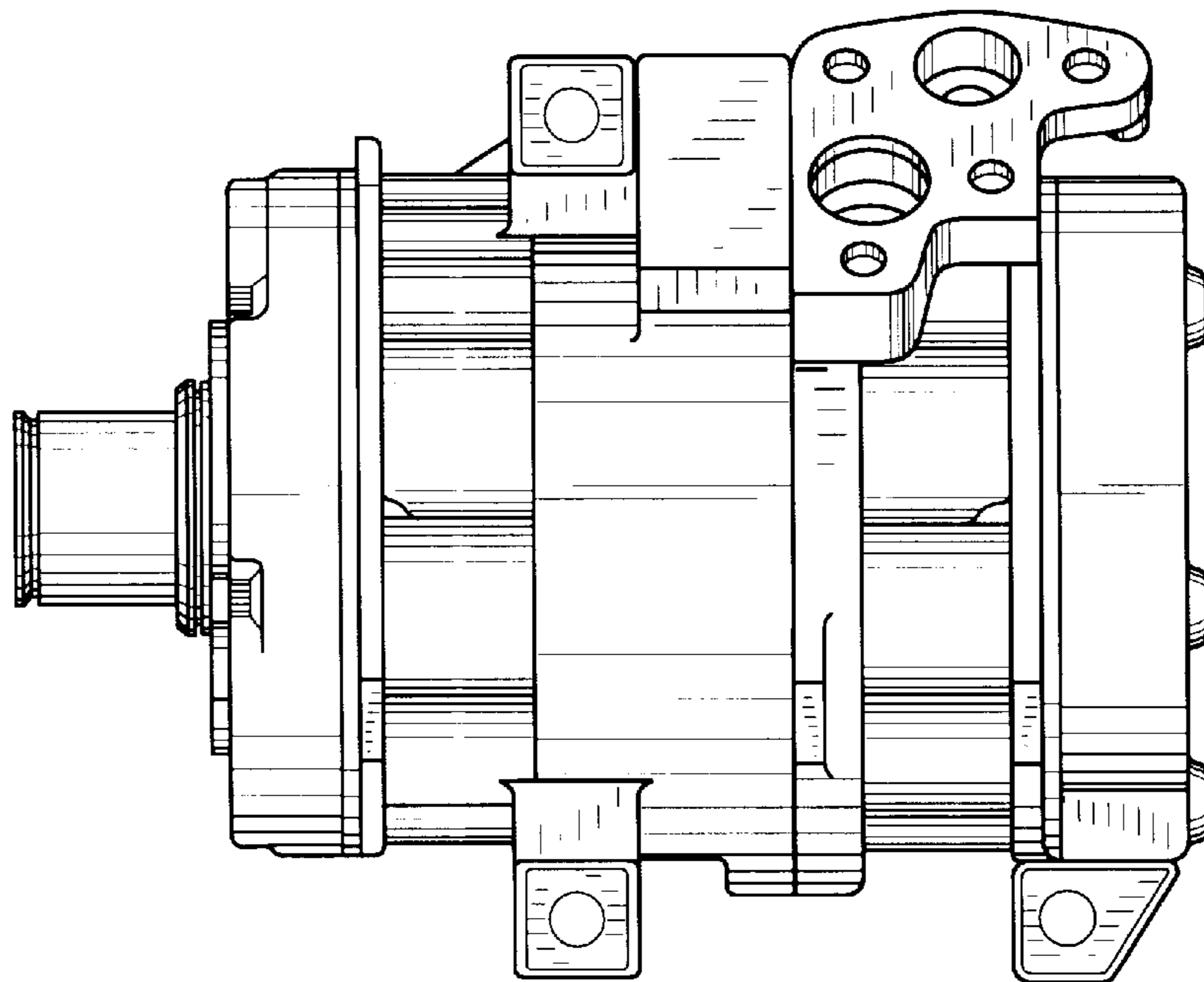

FIG. 7

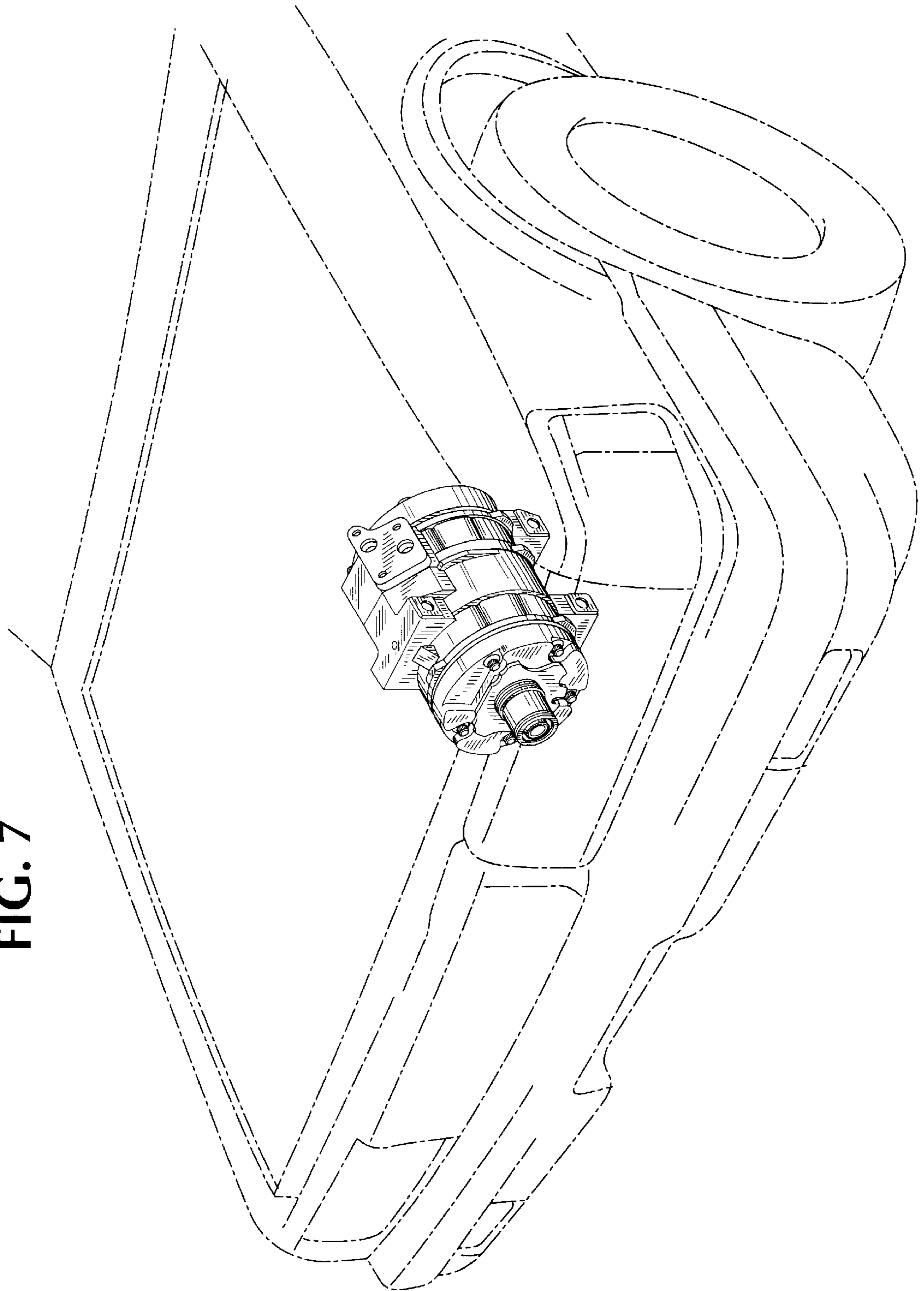

FIG. 8

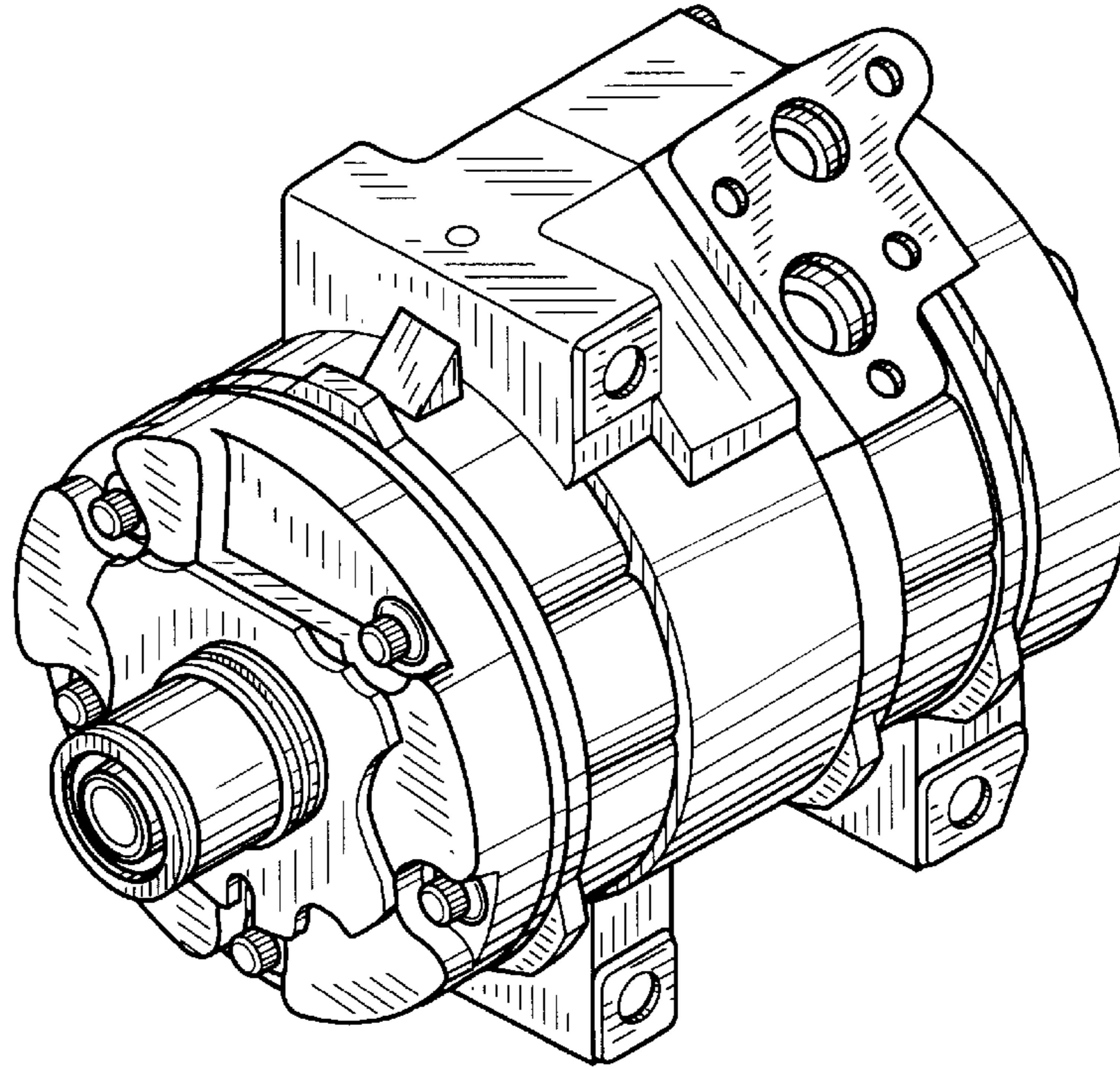

FIG. 9

