



US00D428789S

United States Patent [19]

McHenry et al.

[11] Patent Number: **Des. 428,789**

[45] Date of Patent: **** Aug. 1, 2000**

[54] **KNIFE HANDLE**

[75] Inventors: **William J. McHenry**, Wyoming; **Jason L. Williams**, West Greenwich, both of R.I.

[73] Assignee: **Mentor Group, L.L.C.**, Oregon City, Oreg.

[*] Notice: This patent is subject to a terminal disclaimer.

[**] Term: **14 Years**

[21] Appl. No.: **29/106,190**

[22] Filed: **Jun. 10, 1999**

[51] **LOC (7) Cl.** **08-03**

[52] **U.S. Cl.** **D8/99**

[58] **Field of Search** D8/98, 99, 100, D8/105, 107; 30/151, 152, 153, 154, 155, 156, 157, 158, 159, 160, 161, 162

[56] **References Cited**

U.S. PATENT DOCUMENTS

D. 336,232	6/1993	Thompson et al.	D8/99
D. 365,266	12/1995	Hasegawa	D8/99
D. 384,871	10/1997	McWillis	D8/99
D. 404,990	2/1999	Zowada	D8/99
D. 407,002	3/1999	Morton et al.	D8/99
D. 408,706	4/1999	Elishewitz	D8/99
D. 409,070	5/1999	Elishewitz	D8/98
5,060,379	10/1991	Neely	30/161
5,495,673	3/1996	Gardiner et al.	30/155
5,572,793	11/1996	Collins et al.	30/157

OTHER PUBLICATIONS

Fighting Knives magazine, p. 7, Benchmade knives, May 1996.

Fighting Knives magazine, p. 19, Elishewitz knife, May 1996.

Fighting Knives magazine, p. 39, Elishewitz and Crawford knives, May 1996.

Benchmade Knife Co., Inc. Model 401S—Panther Folding Knife, 1996.

Benchmade Knife Co., Inc. Model 501S—Monarch Folding Hunting Knife, 1996.

Benchmade Knife Co., Inc. 9000SBT—Automatic Knife, 1997.

Primary Examiner—Philip S. Hyder
Attorney, Agent, or Firm—Chernoff, Vilhauer, McClung & Stenzel, LLP

[57] **CLAIM**

The ornamental design for a knife handle, as shown and described.

DESCRIPTION

FIG. 1 is an isometric view from the upper right front of a knife handle showing our new design, wherein the broken-line depiction of a knife blade associated therewith is included merely for illustrative purposes and forms no part of our claimed design;

FIG. 2 is a right side elevational view of the knife handle shown in FIG. 1, the left side elevational view thereof being a mirror image of this view;

FIG. 3 is a top plan, or back, view of the knife handle shown in FIG. 2;

FIG. 4 is a bottom plan view thereof;

FIG. 5 is a rear, or butt, end elevational view thereof; and,

FIG. 6 is a front, or blade, end elevational view thereof.

1 Claim, 2 Drawing Sheets

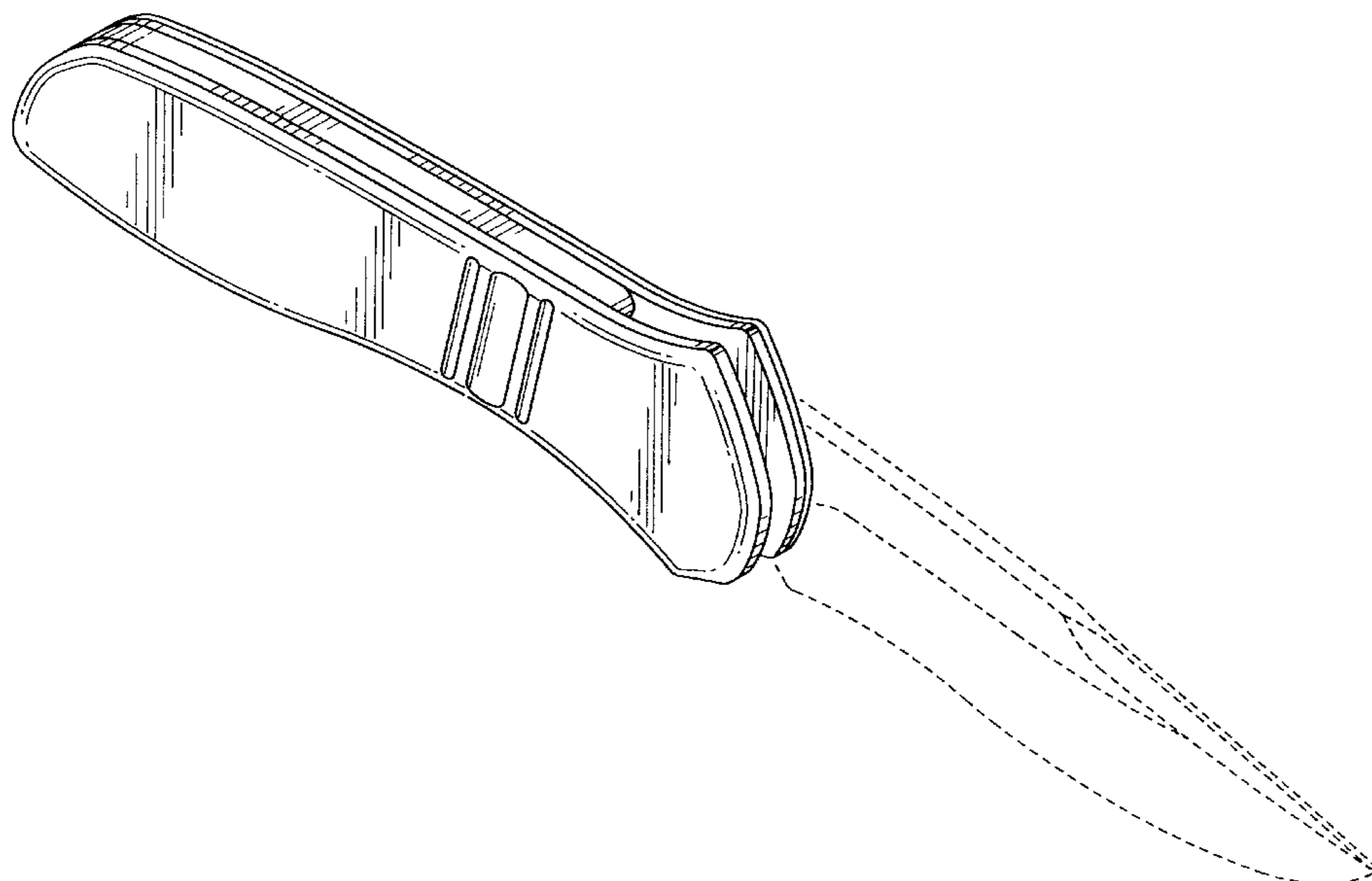

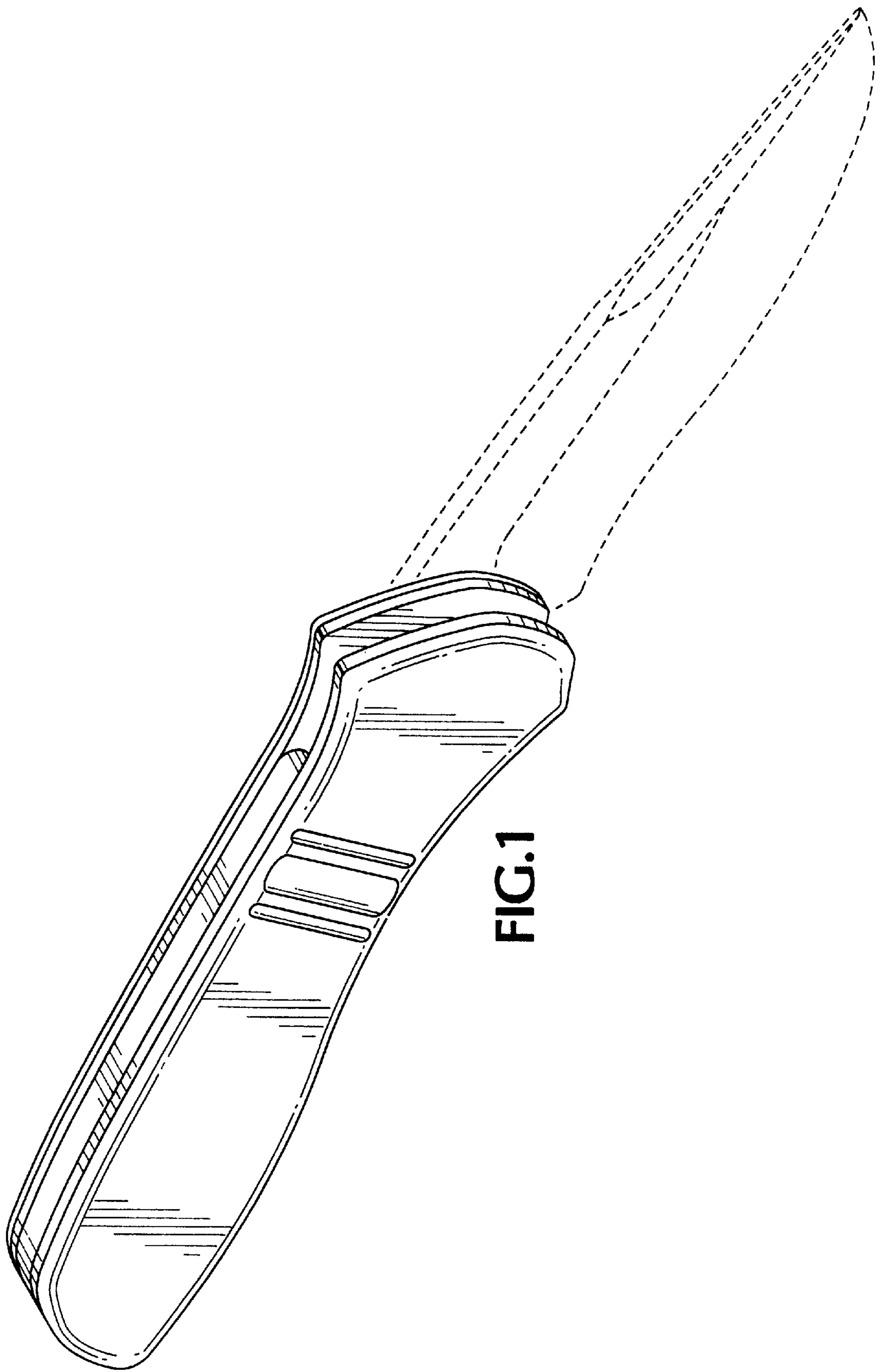

FIG. 1



FIG.3

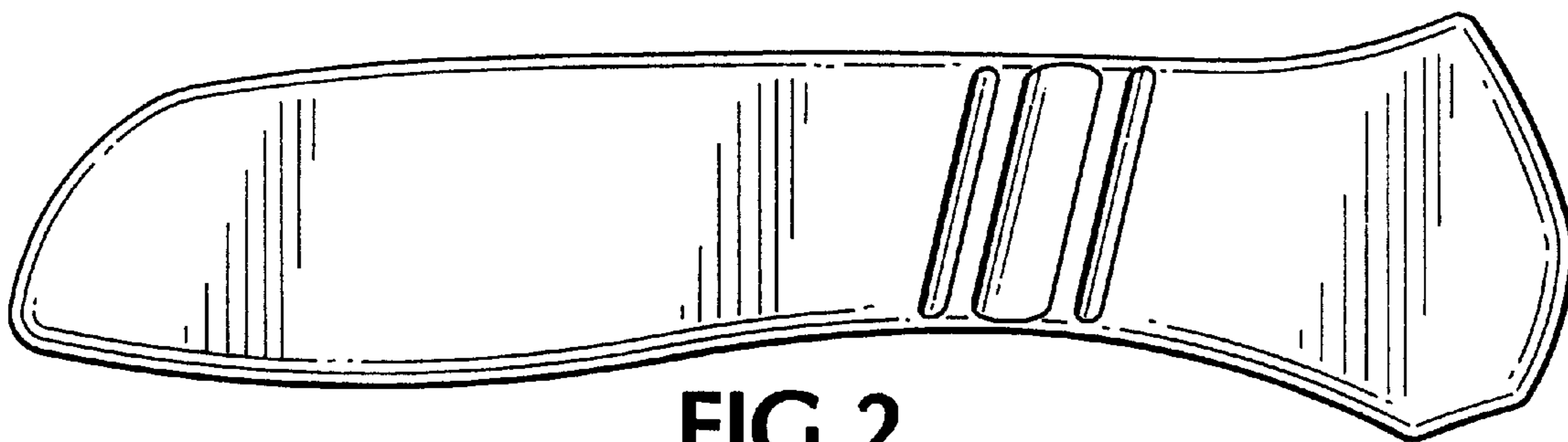

FIG.2

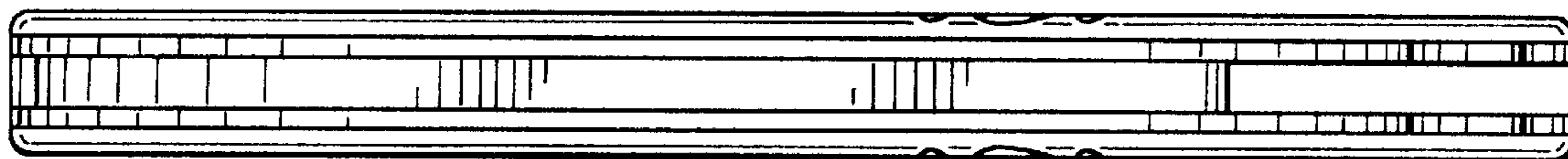

FIG.4

FIG.5

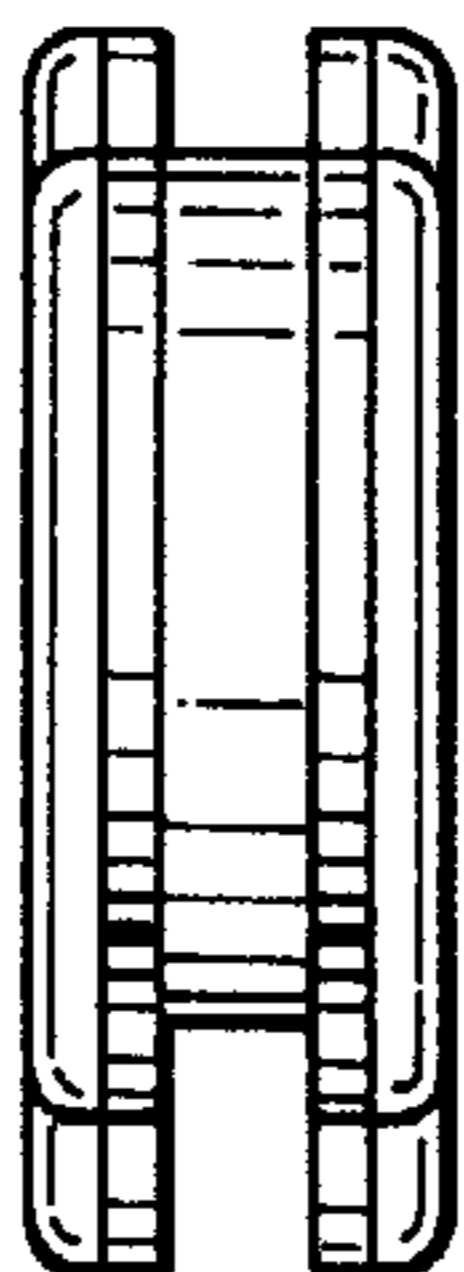

FIG.6

