



US00D428381S

**United States Patent** [19]  
**Hartmann et al.**

[11] **Patent Number: Des. 428,381**  
[45] **Date of Patent: \*\* Jul. 18, 2000**

[54] **SUPERSONIC BUSINESS JET**

5,740,984 4/1998 Morgenstern ..... 244/45 A  
5,842,666 12/1998 Gerhardt et al. .... 244/15

[75] Inventors: **Thomas M. Hartmann**, Canyon Country; **John M. Morgenstern**, Palmdale; **Daniel H. Sokol**, Canyon Country, all of Calif.

*Primary Examiner*—Kay H. Chin  
*Attorney, Agent, or Firm*—Robert A. Schruhl

[73] Assignee: **Lockheed Martin Corporation**, Palmdale, Calif.

[57] **CLAIM**

The ornamental design for a supersonic business jet, as shown.

[\*\*] Term: **14 Years**

**DESCRIPTION**

[21] Appl. No.: **29/093,380**

FIG. 1 is a top and right side perspective view of a supersonic business jet showing our new design;

[22] Filed: **Sep. 8, 1998**

FIG. 2 is a left side elevational view thereof;

[51] **LOC (7) Cl.** ..... **12-07**

[52] **U.S. Cl.** ..... **D12/332; D12/333; D12/341**

FIG. 3 is a top plan view thereof;

[58] **Field of Search** ..... **D12/319, 331,**

**D12/332, 333, 334, 336, 338, 340, 341,**

**342, 343; 244/15, 45 A, 45 R**

FIG. 4 is a bottom plan view thereof;

FIG. 5 is a front elevational view thereof; and,

FIG. 6 is a rear elevational view thereof.

[56] **References Cited**

**U.S. PATENT DOCUMENTS**

D. 278,700 5/1985 Powers et al. .... D12/342

**1 Claim, 5 Drawing Sheets**

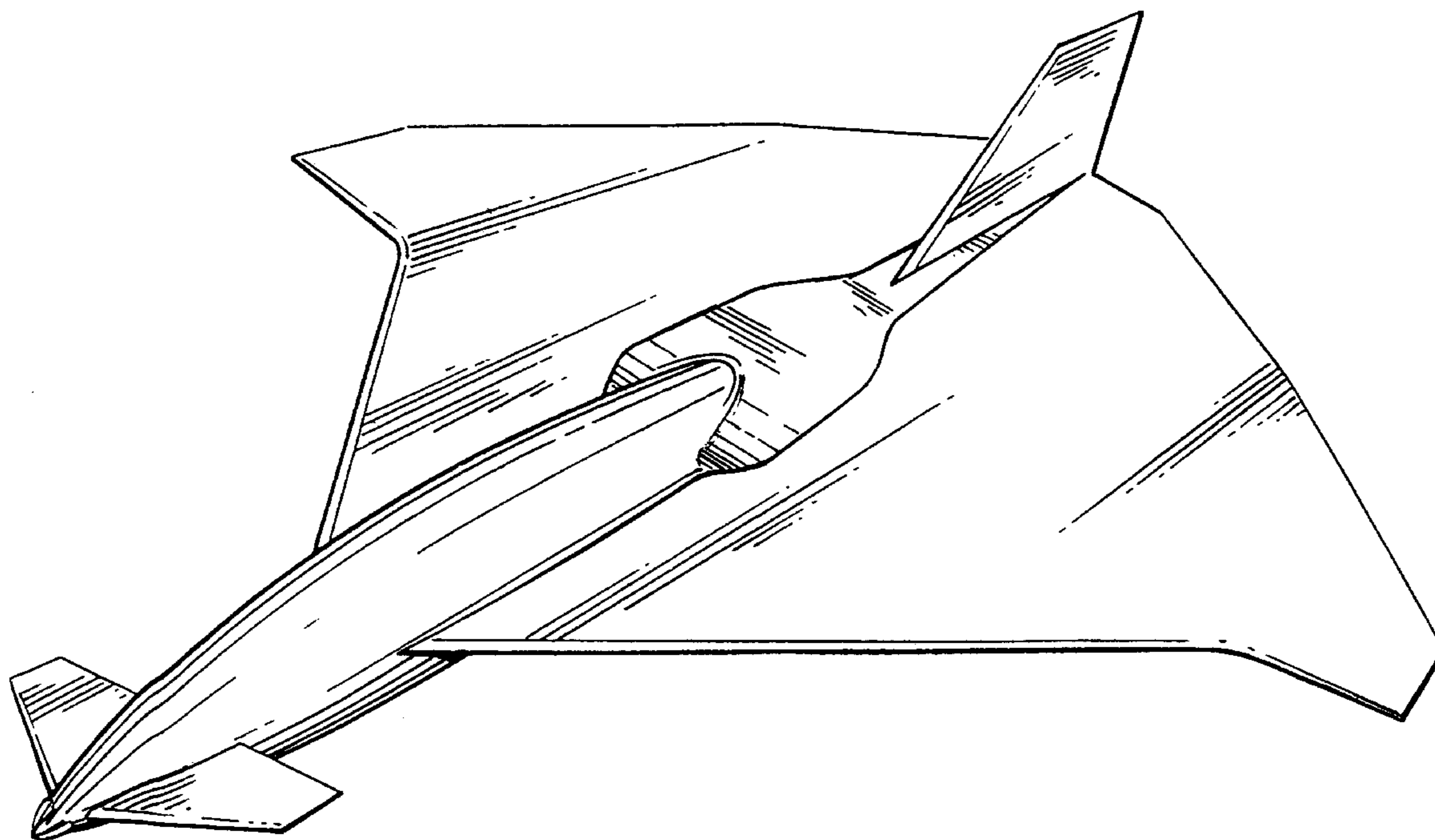

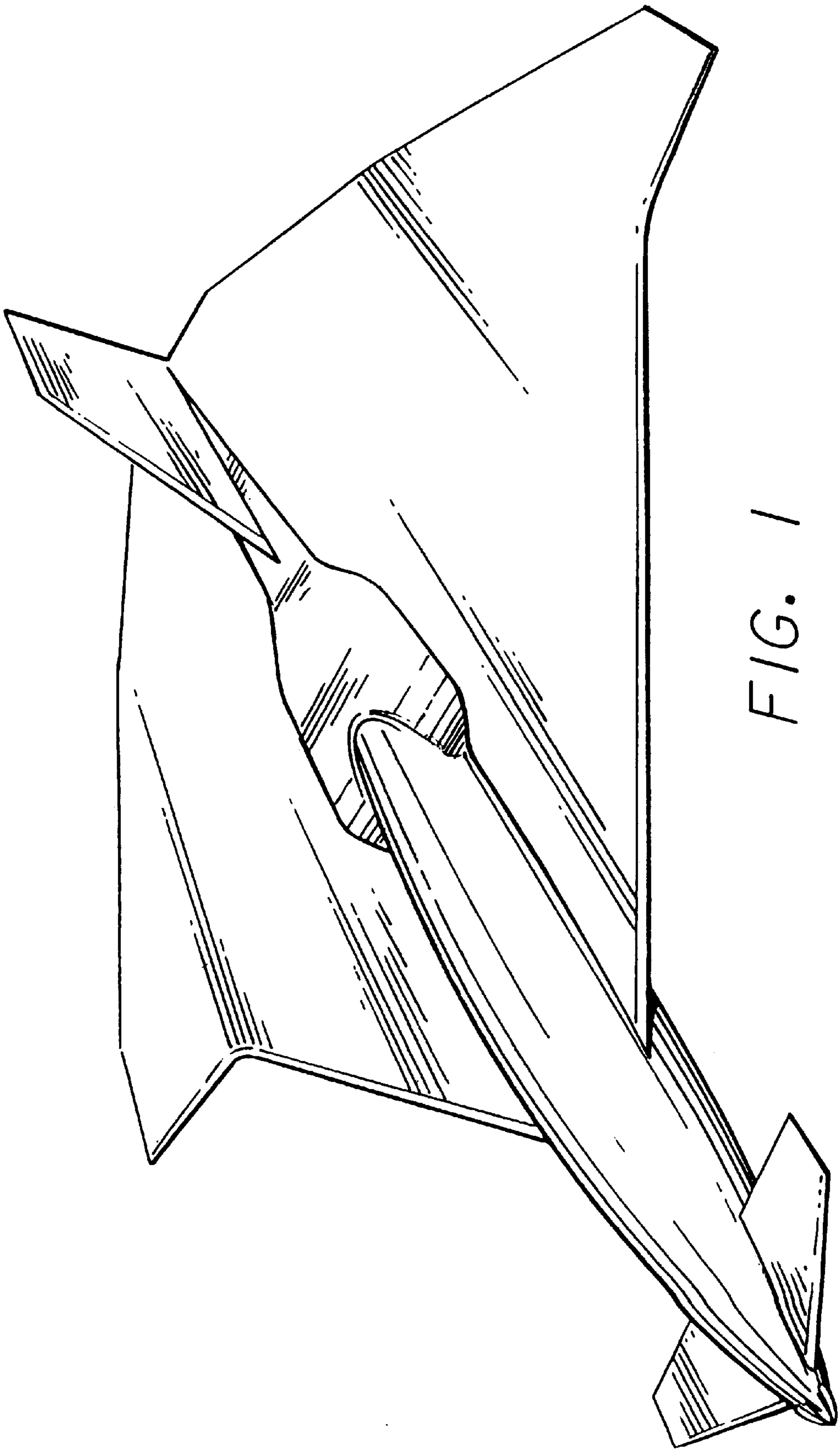

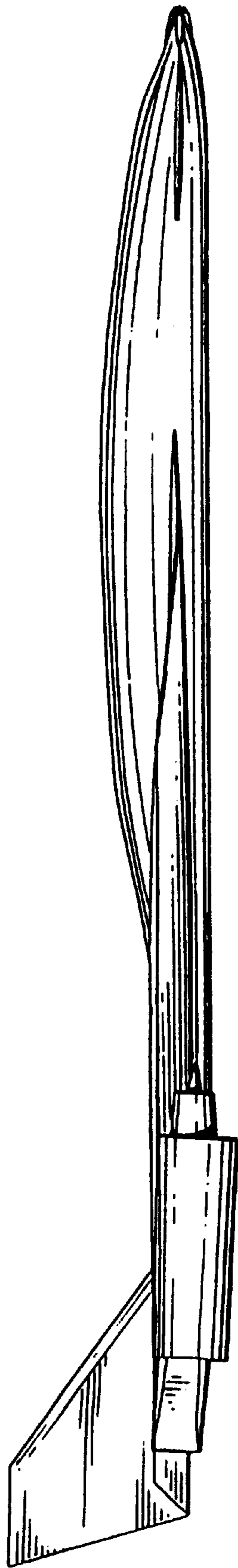

FIG. 2

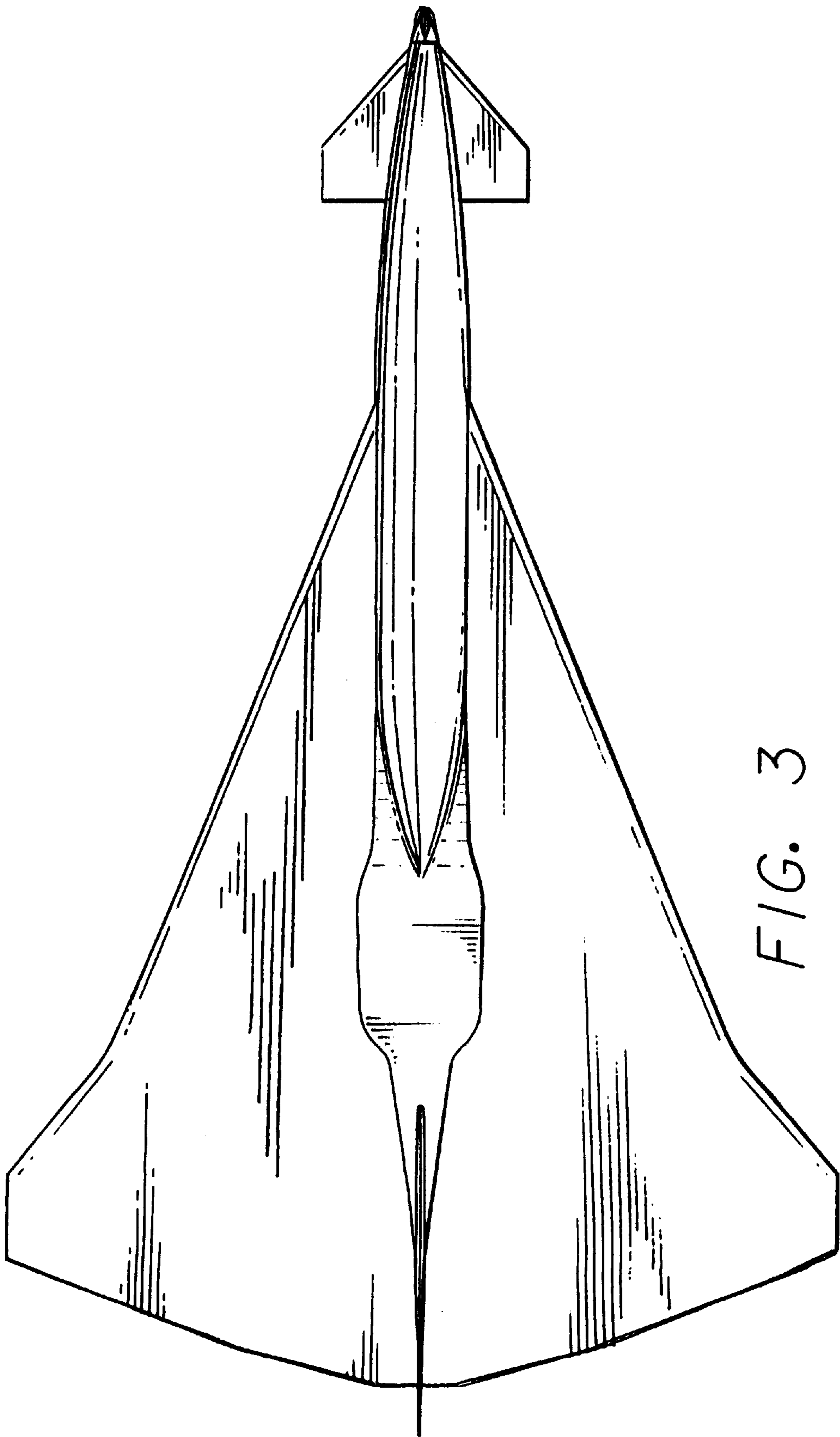

FIG. 3

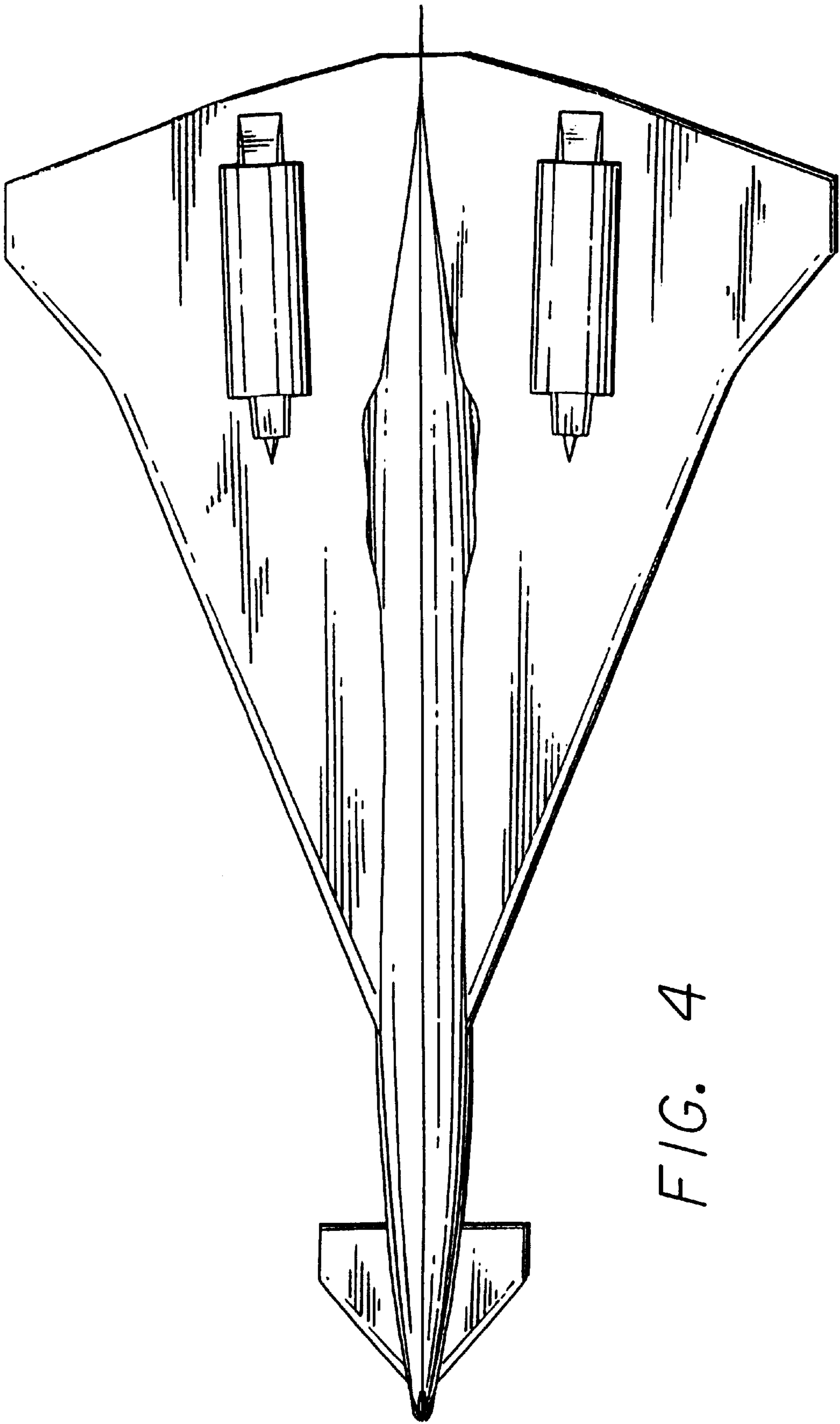

FIG. 4

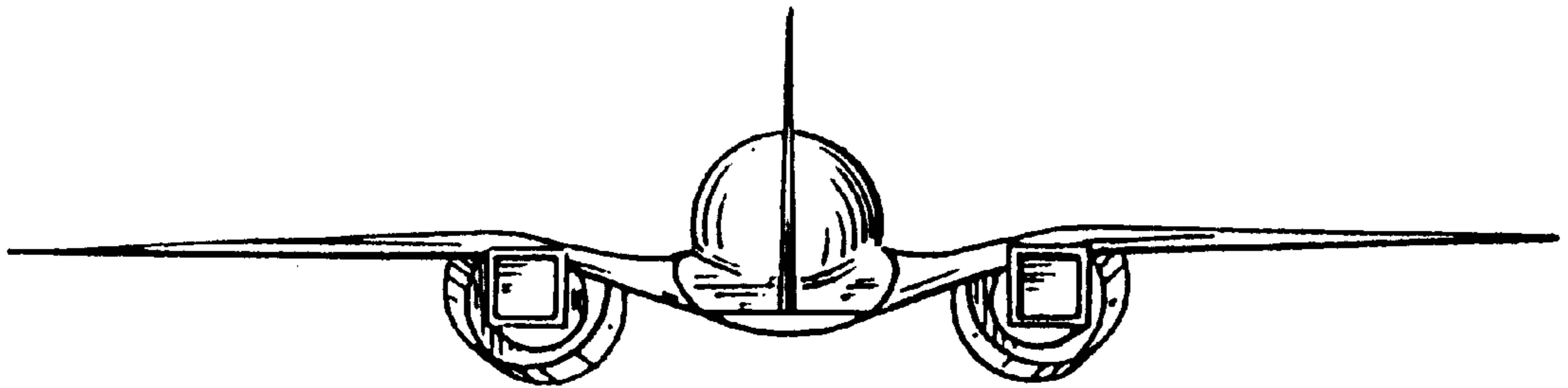

FIG. 5

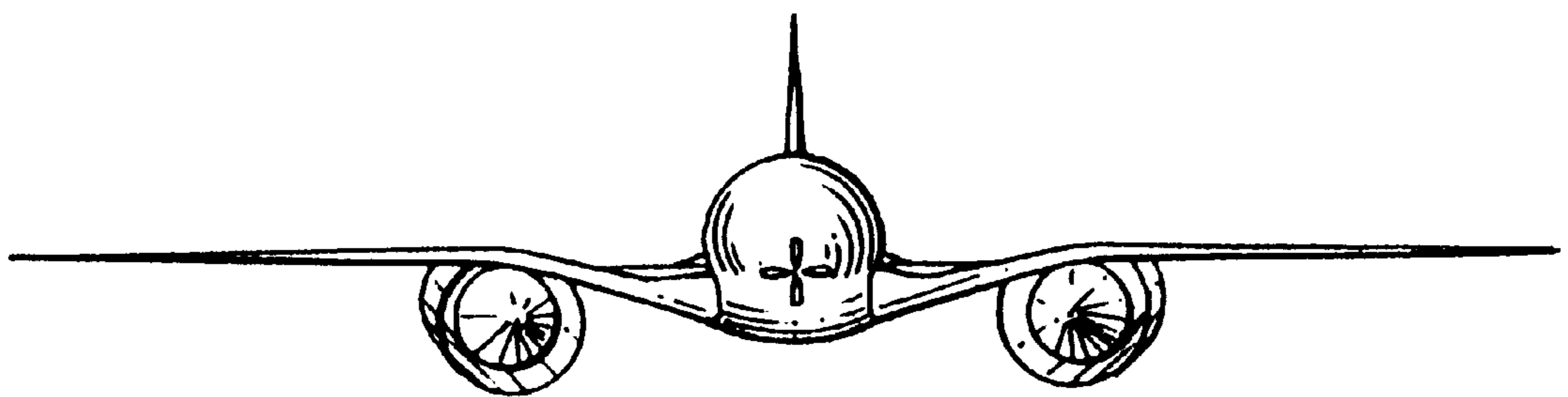

FIG. 6