



US00D428376S

United States Patent [19]

Sacco et al.

[11] **Patent Number: Des. 428,376**

[45] **Date of Patent: ** Jul. 18, 2000**

[54] **TRUNK LID FOR MOTOR VEHICLE**

D. 417,645 12/1999 Horbury et al. D12/196

[75] Inventors: **Bruno Sacco**, Sindelfingen; **Peter Pfeiffer**, Boeblingen, both of Germany

Primary Examiner—Melody N. Brown
Attorney, Agent, or Firm—Evenson, McKeown, Edwards & Lenahan, P.L.L.C.

[73] Assignee: **DaimlerChrysler AG**, Germany

[57] **CLAIM**

[**] Term: **14 Years**

The ornamental design for a trunk lid for motor vehicle, as shown and described.

[21] Appl. No.: **29/106,864**

[22] Filed: **Jun. 24, 1999**

DESCRIPTION

[30] **Foreign Application Priority Data**

FIG. 1 is a perspective view of a trunk lid for motor vehicle according to our novel design;
FIG. 2 is a top view of the trunk lid for motor vehicle according to our novel design;
FIG. 3 is a rear view of the trunk lid for motor vehicle according to our novel design;
FIG. 4 is a left view of the trunk lid for motor vehicle according to our novel design; and,
FIG. 5 is a right view of the trunk lid for motor vehicle according to our novel design.

Dec. 24, 1998 [DE] Germany 498 12 483

[51] **LOC (7) Cl.** **12-16**

[52] **U.S. Cl.** **D12/196**

[58] **Field of Search** D12/196, 90-92;
296/185

The broken lines shown in FIGS. 1, 3, 4 and 5 are shown for illustrative purposes only and form no part of the claimed design.

[56] **References Cited**

U.S. PATENT DOCUMENTS

- D. 323,137 1/1992 Georgia D12/196
- D. 375,315 11/1996 Noyashima D12/196
- D. 387,318 12/1997 Lagaay et al. D12/196
- D. 414,734 10/1999 Banyle D12/196

1 Claim, 3 Drawing Sheets

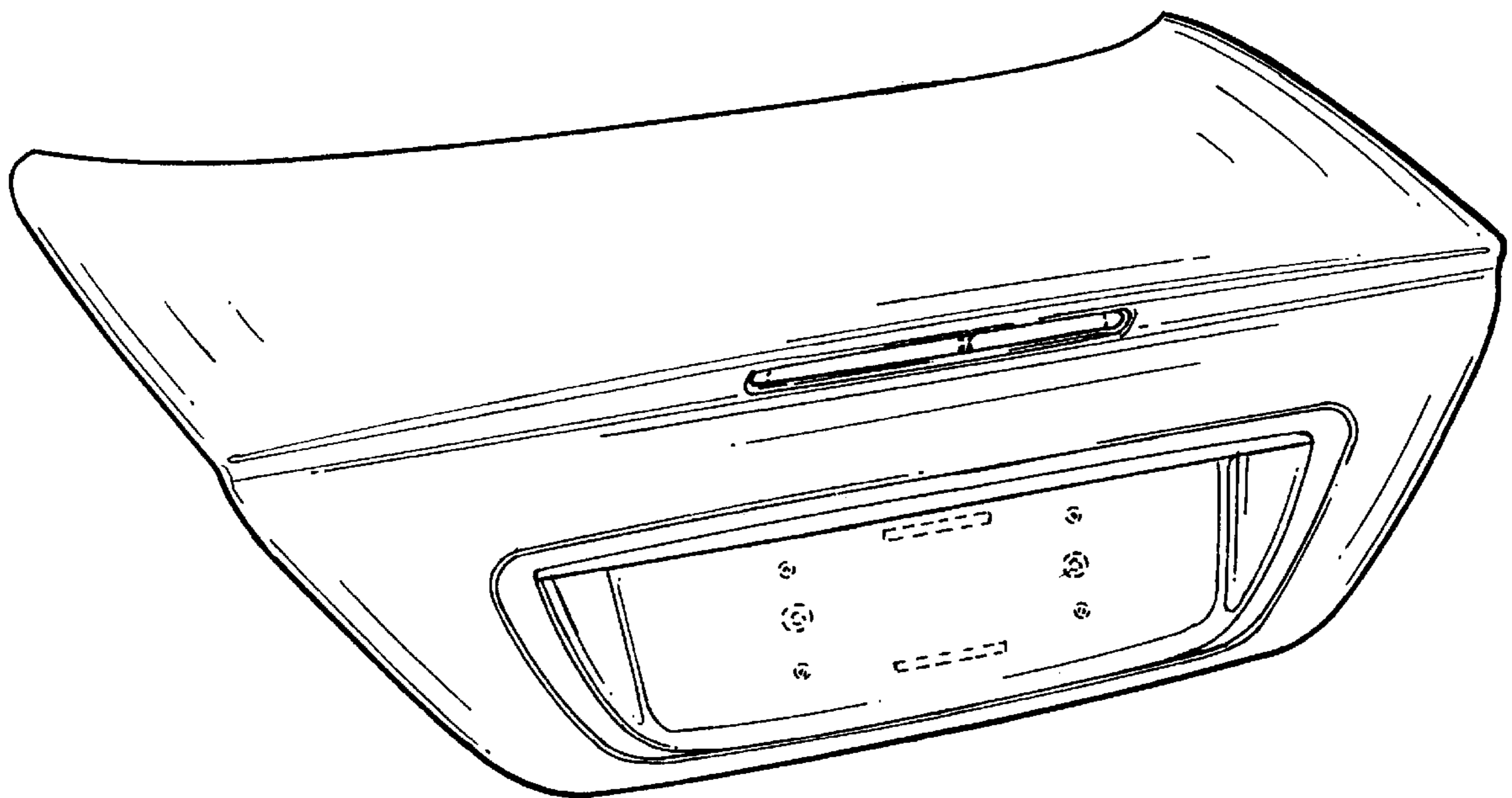

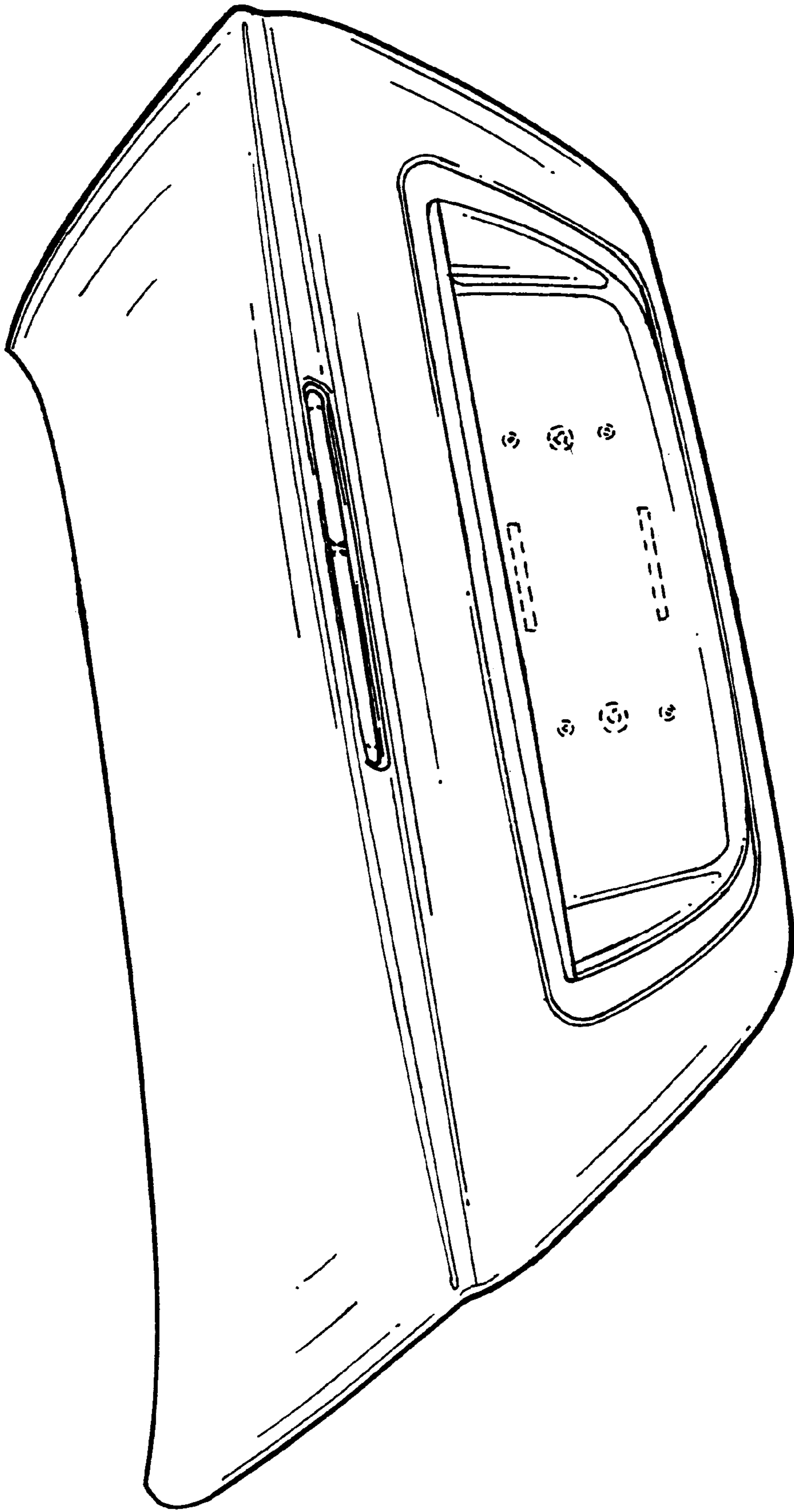

FIG. 1



FIG. 2

