



US00D428364S

United States Patent [19] Kirkpatrick

[11] Patent Number: Des. 428,364

[45] Date of Patent: ** Jul. 18, 2000

[54] **MOTORIZED VEHICLE**

[76] Inventor: **James R. Kirkpatrick**, 2235 Clement Ave., Alameda, Calif. 94501

[**] Term: **14 Years**

[21] Appl. No.: **29/088,304**

[22] Filed: **May 20, 1998**

[51] **LOC (7) Cl.** **12-11**

[52] **U.S. Cl.** **D12/112**

[58] **Field of Search** D12/112, 113, D12/118, 107; 280/267, 282, 259, 293

[56] **References Cited**

U.S. PATENT DOCUMENTS

| | | | | |
|------------|---------|---------|-------|---------|
| D. 162,540 | 3/1951 | Hsu | | D12/112 |
| D. 176,037 | 11/1955 | Rhoades | | D12/112 |
| D. 210,758 | 4/1968 | Binder | | D12/112 |
| D. 308,499 | 6/1990 | Berger | | D12/112 |
| D. 314,547 | 2/1991 | Kelly | | D12/112 |

Primary Examiner—Alan P. Douglas
Assistant Examiner—Linda Brooks
Attorney, Agent, or Firm—Chupa & Alberti, P.C.

[57] **CLAIM**

The ornamental design for a motorized vehicle, as shown.

DESCRIPTION

FIG. 1 is a right perspective view of a motorized vehicle in accordance with the teachings of the preferred embodiment of the invention;

FIG. 2 is a left perspective view of the motorized vehicle shown in FIG. 1;

FIG. 3 is a front view of the motorized vehicle shown in FIGS. 1 and 2;

FIG. 4 is a right side view of the motorized vehicle shown in FIGS. 1, 2, and 3; and,

FIG. 5 is an enlarged top view of the motorized vehicle shown in FIGS. 1, 2, 3, and 4.

1 Claim, 2 Drawing Sheets

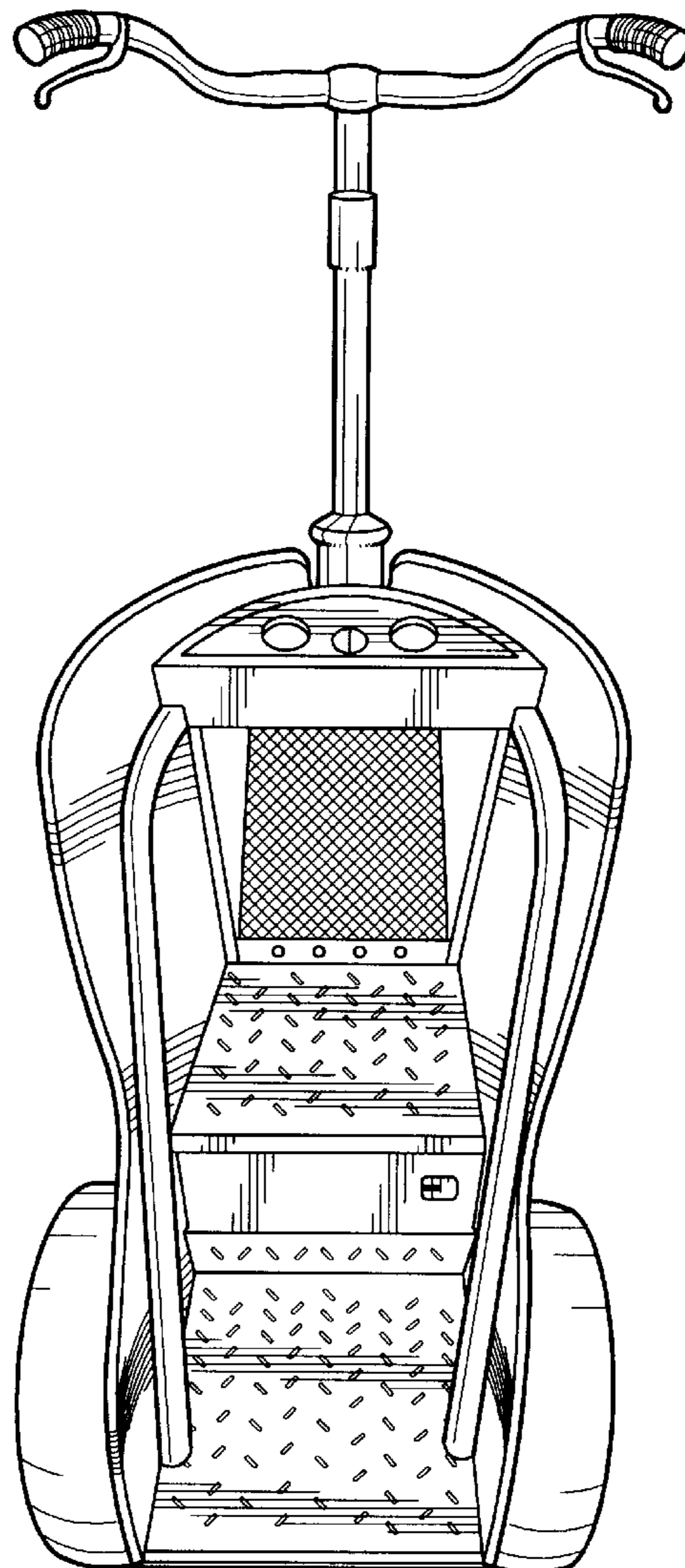
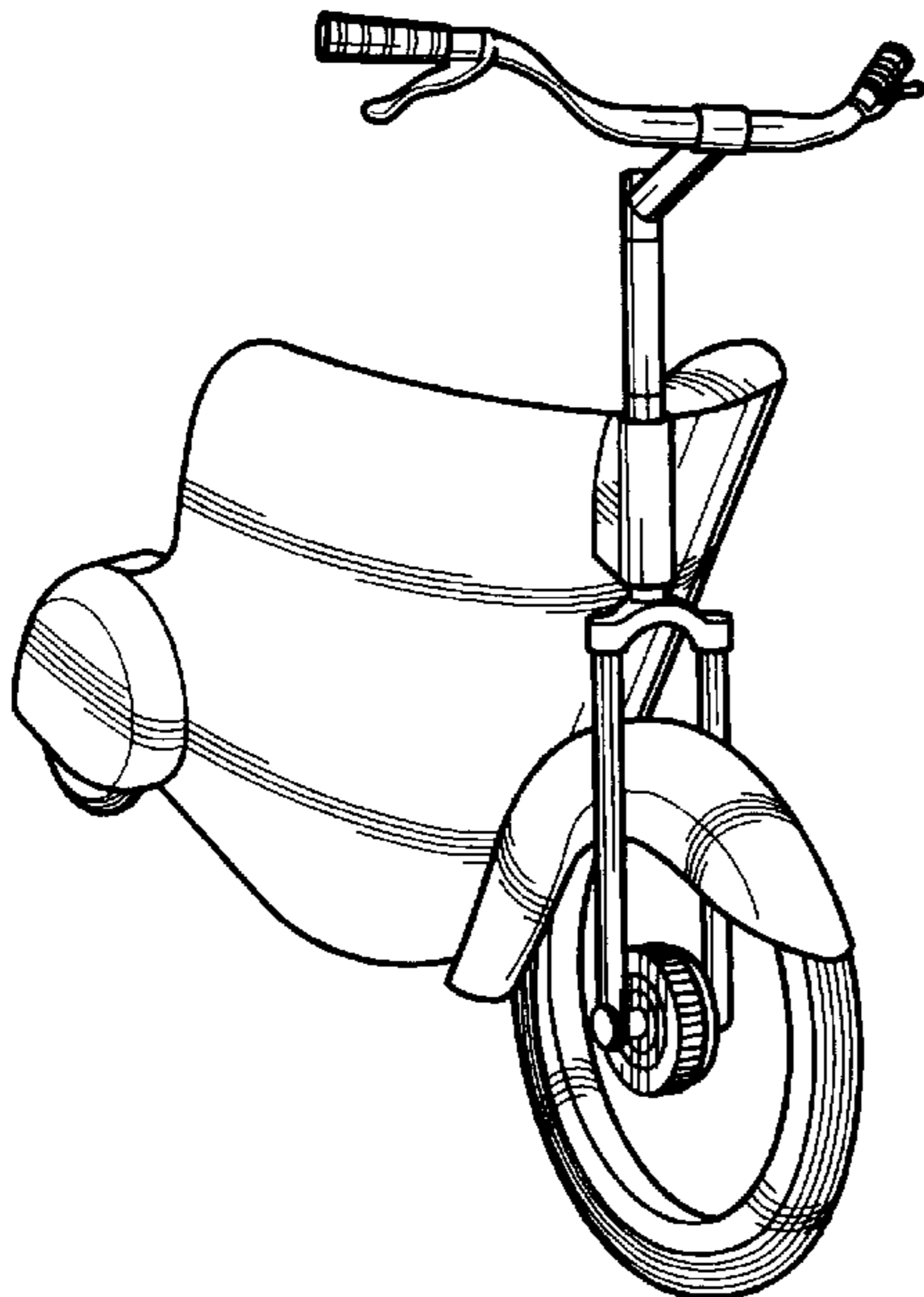

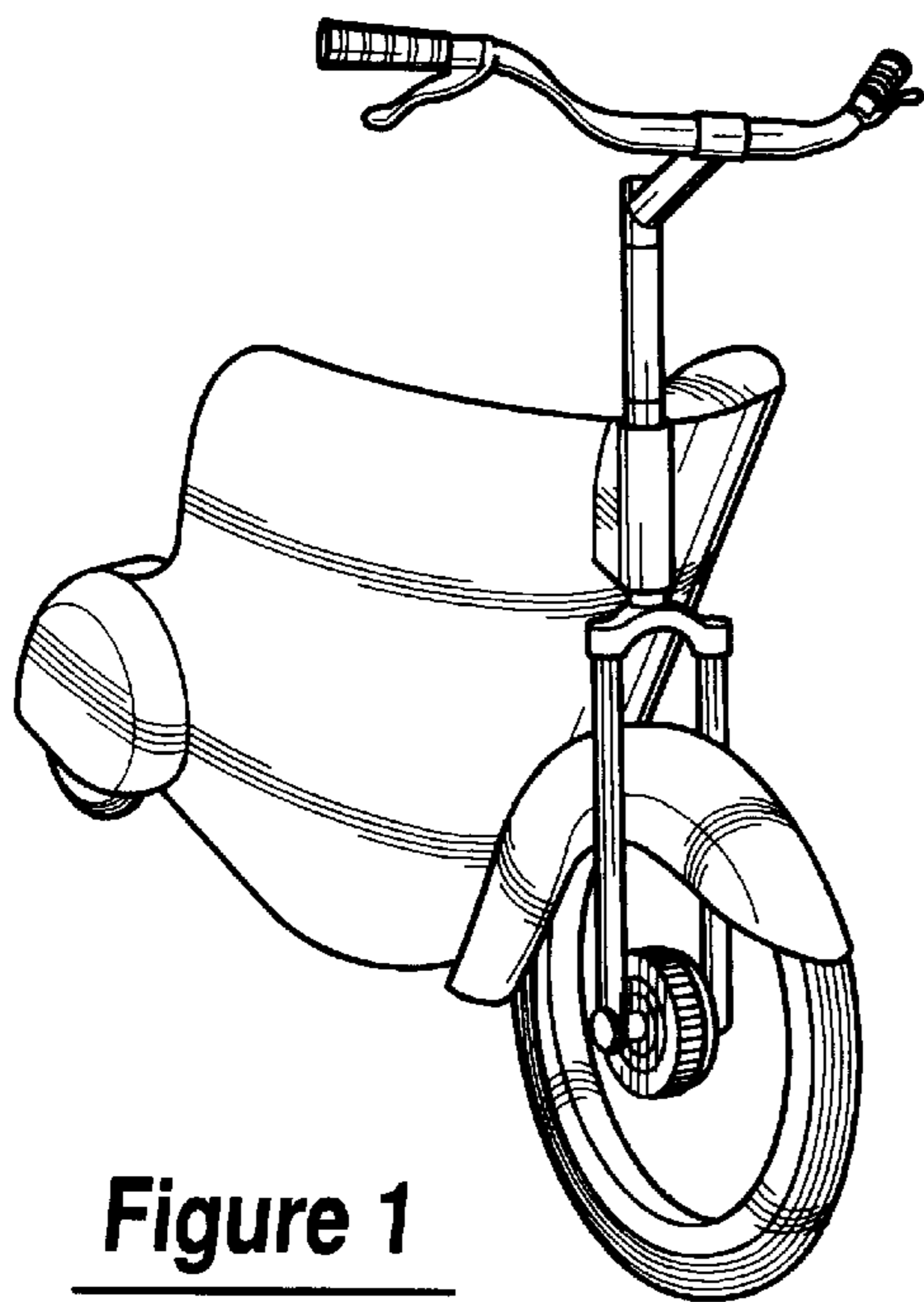

Figure 1

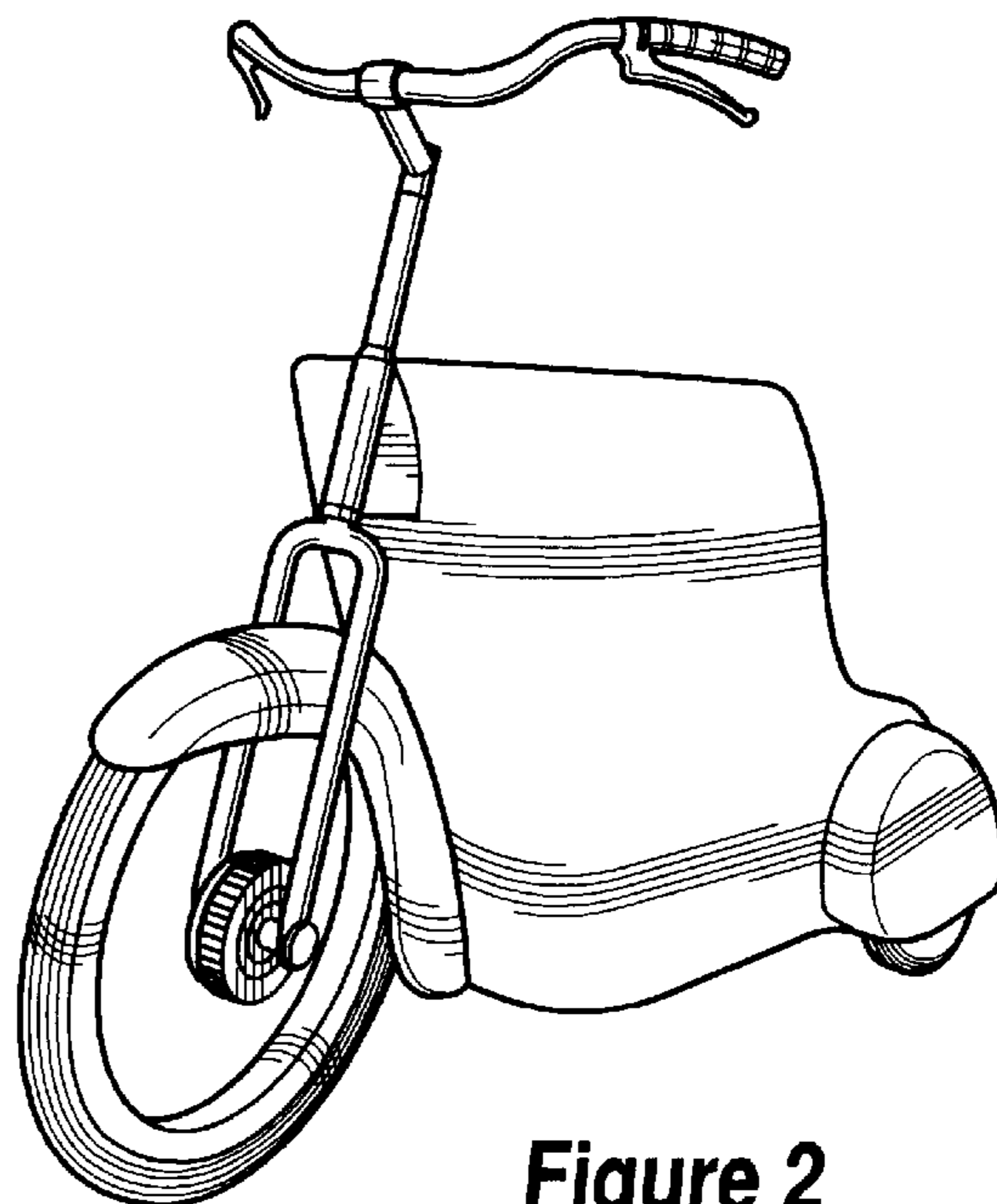

Figure 2

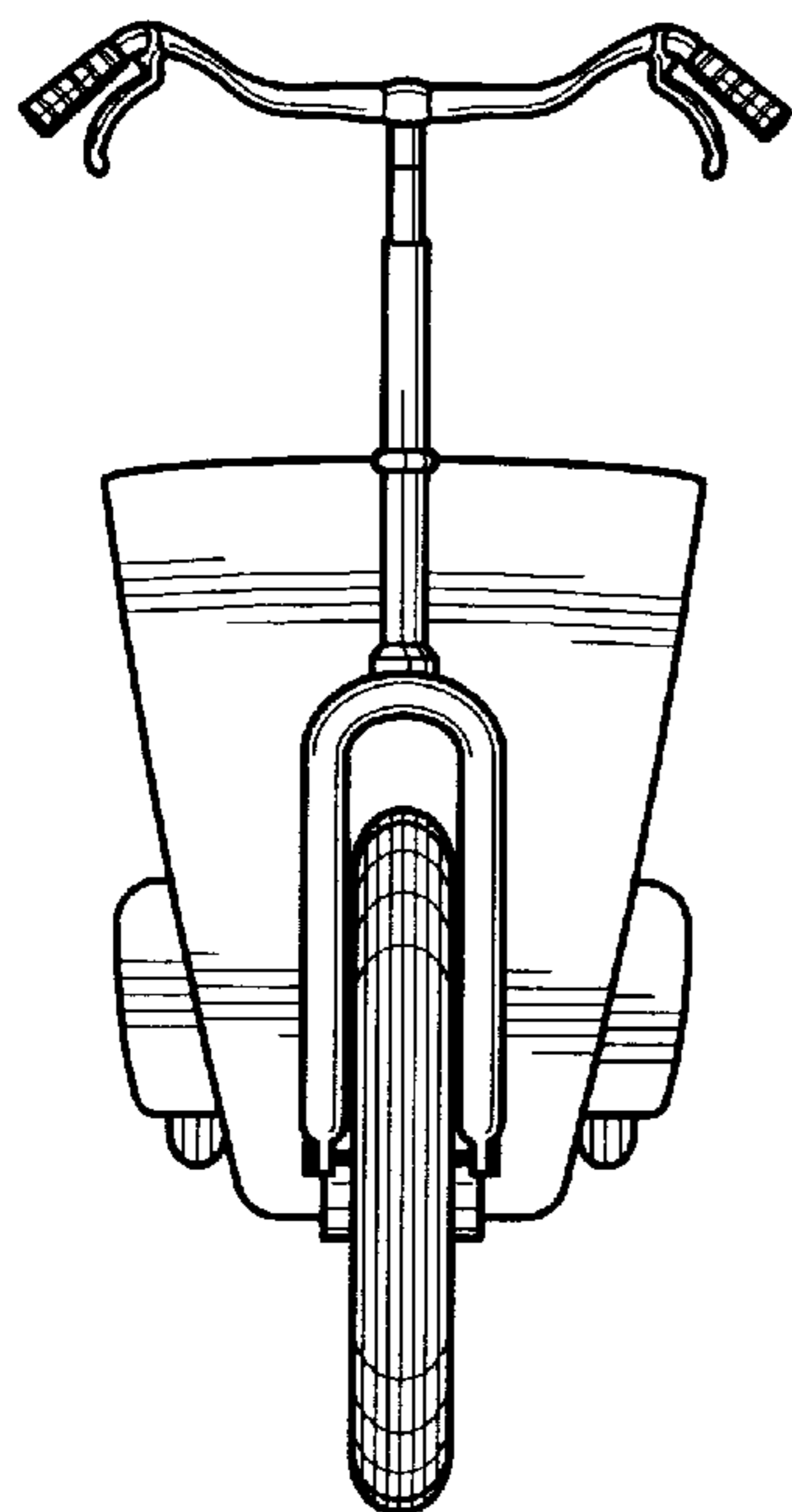

Figure 3

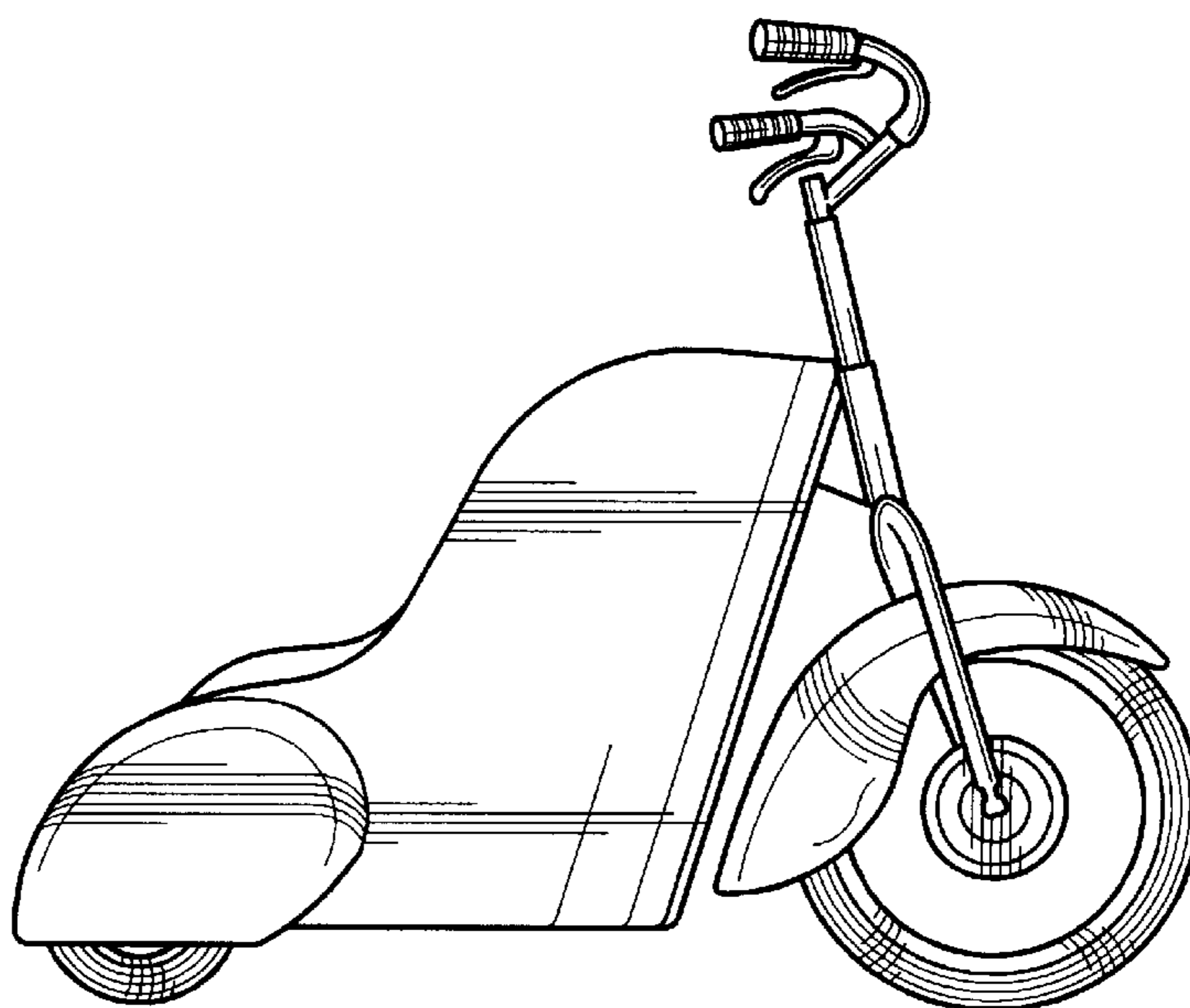

Figure 4

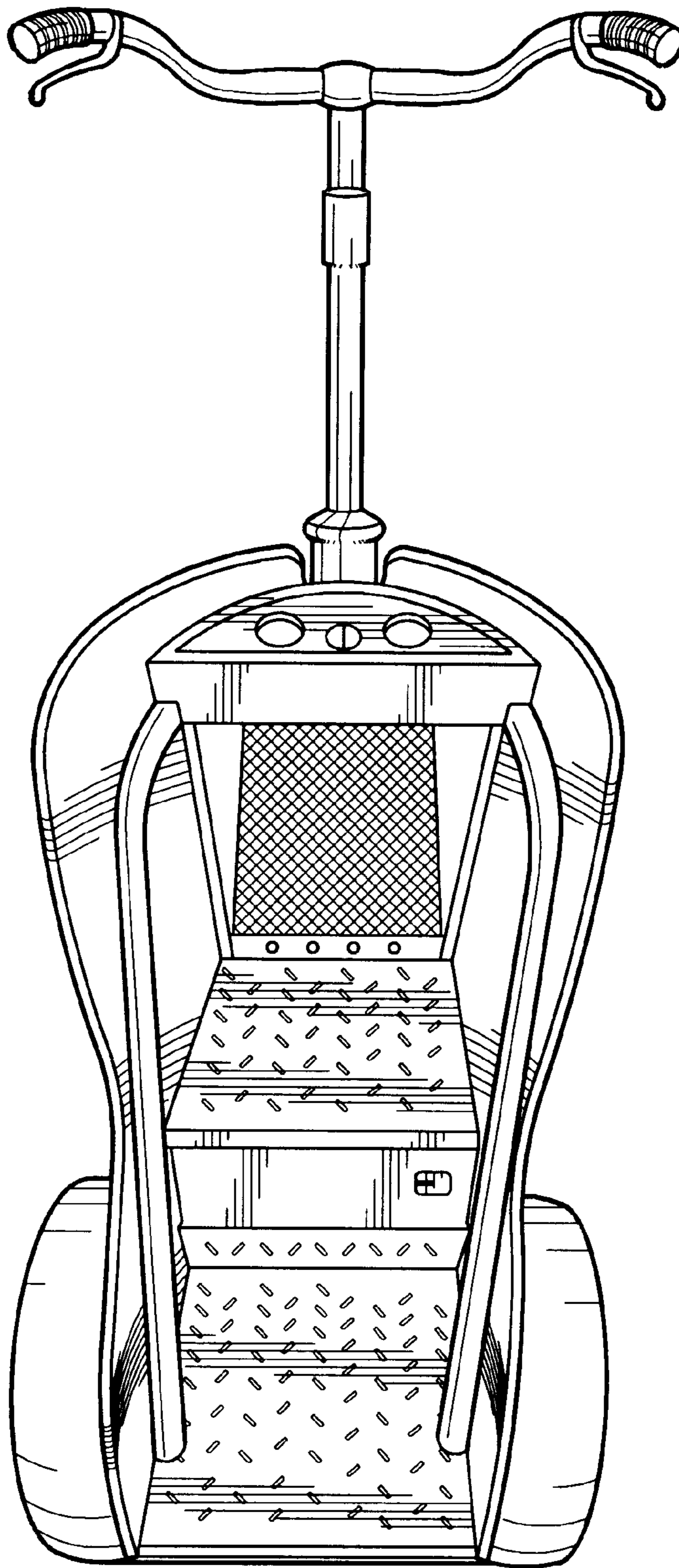

Figure 5