



US00D428022S

United States Patent [19]

[11] Patent Number: Des. 428,022

Altmann et al.

[45] Date of Patent: ** Jul. 11, 2000

[54] DASH COWL

OTHER PUBLICATIONS

[75] Inventors: Caryn M. Altmann, Buffalo Grove; Thomas M. Cameron, Waukegan; Eugene J. Golec, Mt. Prospect, all of Ill.; Jeffrey E. Hallgren, Menasha, Wis.; Hadyn H. Kerner, Ingleside, Ill.

John Deere "Firepower" Tractor, rec'd Mar. 1991.p. 32, Tractor panel.

Primary Examiner—Sandra L. Morris
Attorney, Agent, or Firm—Edward G. Fiorito

[73] Assignee: **Komatsu America International Company**, Vernon Hills, Ill.

[57] CLAIM

We claim the ornamental design for a dash cowl, as shown and described.

[**] Term: 14 Years

DESCRIPTION

[21] Appl. No.: 29/096,484

FIG. 1 is a perspective view illustrating the environment of a dash cowl, showing our new design; FIG. 2 is an enlarged left side perspective view thereof; FIG. 3 is an enlarged top plan view thereof; FIG. 4 is an enlarged bottom plan view thereof; FIG. 5 is an enlarged front elevational view thereof; FIG. 6 is an enlarged rear elevational view thereof; FIG. 7 is an enlarged right side elevational view thereof; and, FIG. 8 is an enlarged left side elevational view thereof. The elements shown in broken lines are for illustrative purposes only.

[22] Filed: Nov. 13, 1998

[51] LOC (7) Cl. 15-03

[52] U.S. Cl. D15/28

[58] Field of Search D12/415-424;
D14/100-102; D15/10, 22-26, 28, 30, 31;
180/90; 296/70; 362/30

[56] References Cited

U.S. PATENT DOCUMENTS

D. 326,662 6/1992 Holm et al. D15/17
4,447,860 5/1984 Stone et al. 362/30

1 Claim, 4 Drawing Sheets

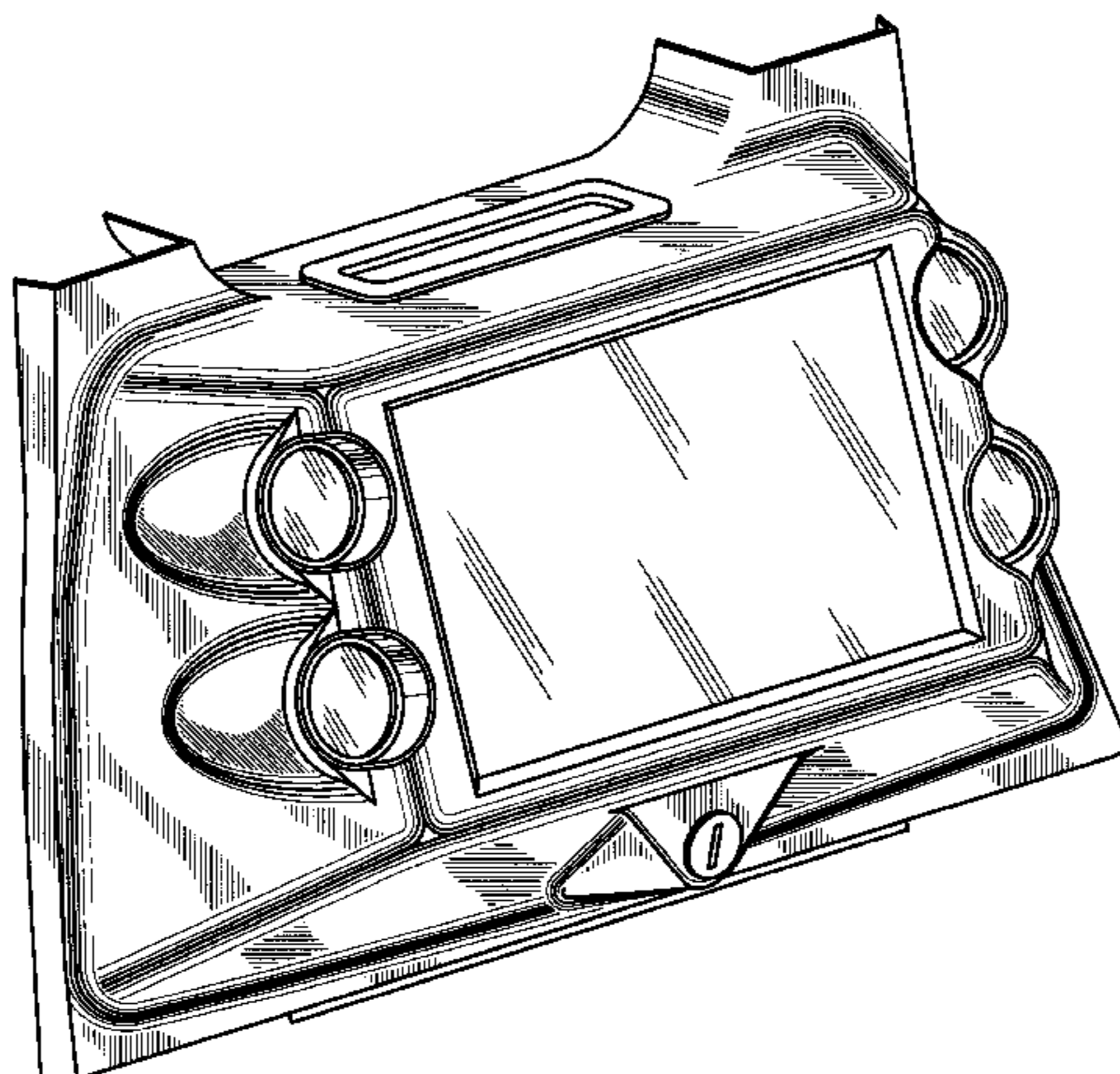
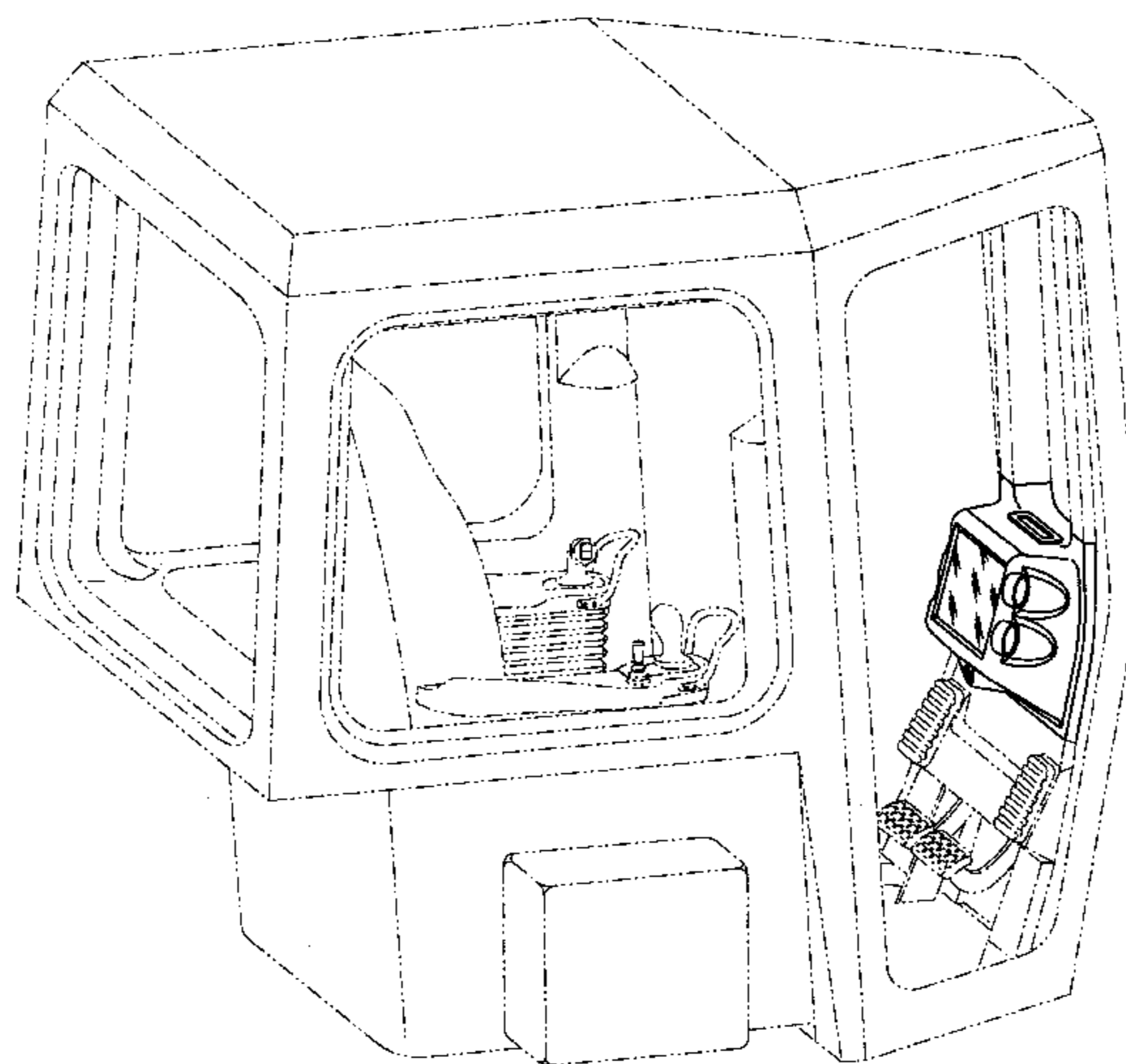

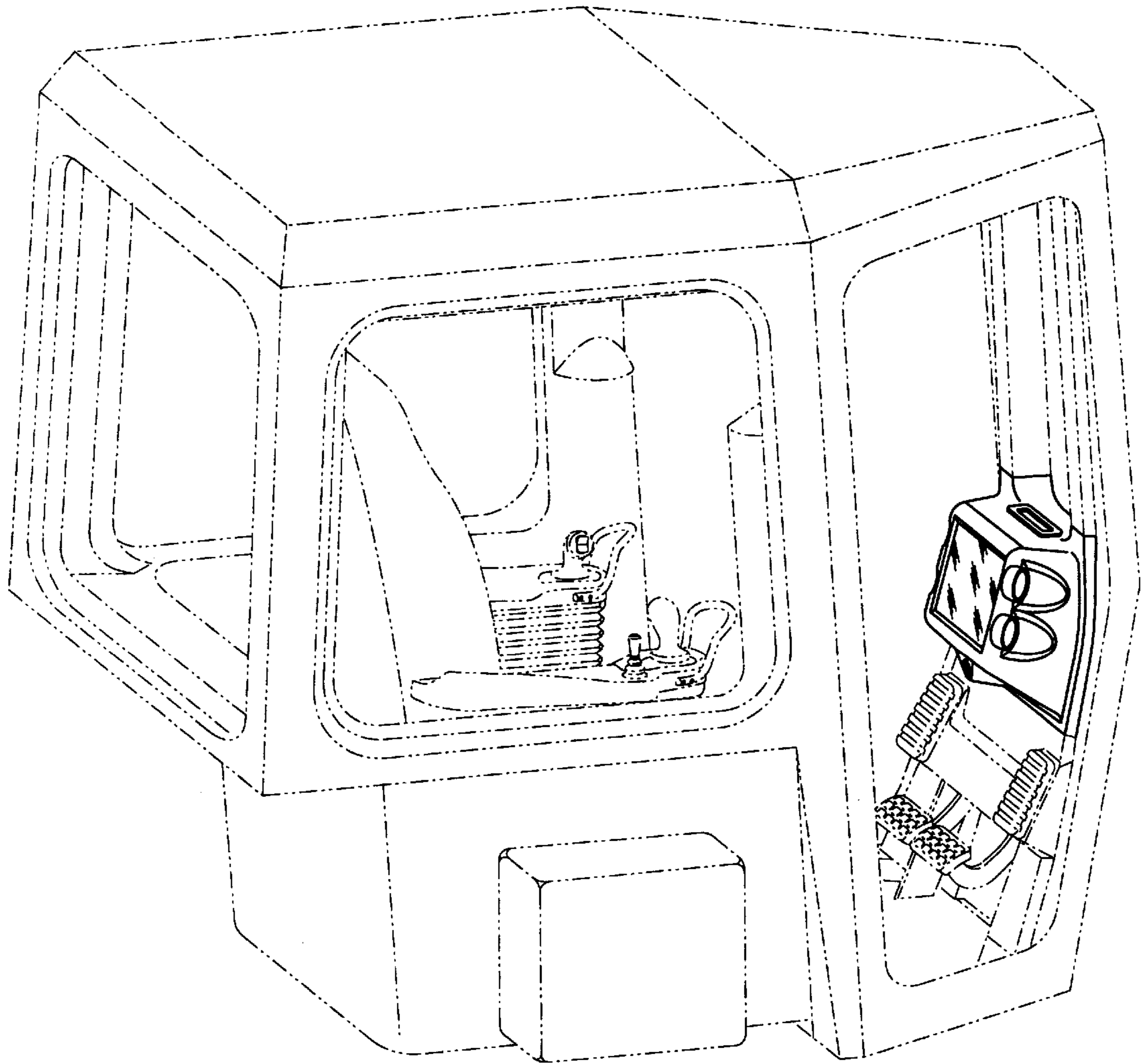

Fig.1

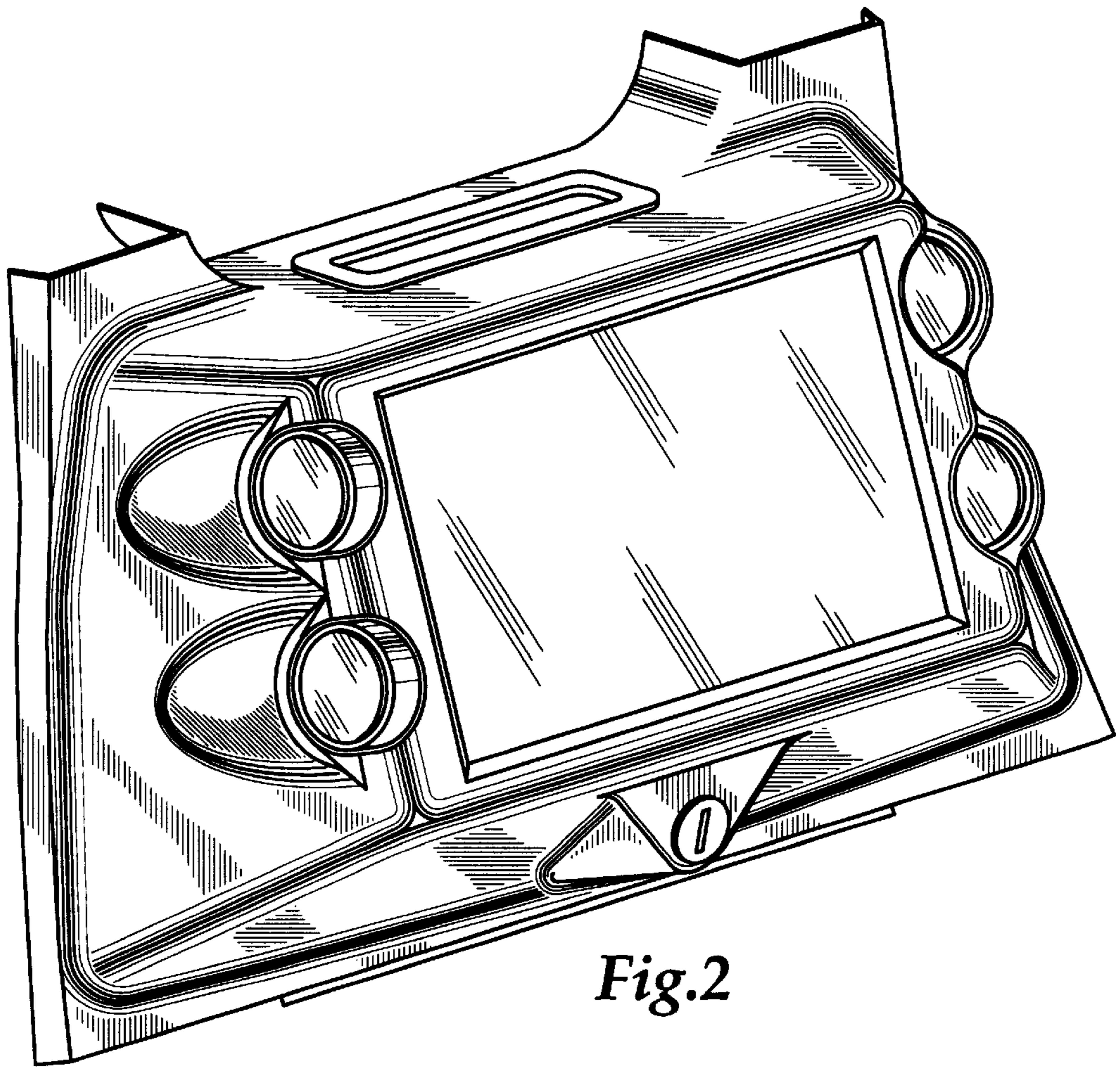

Fig.2

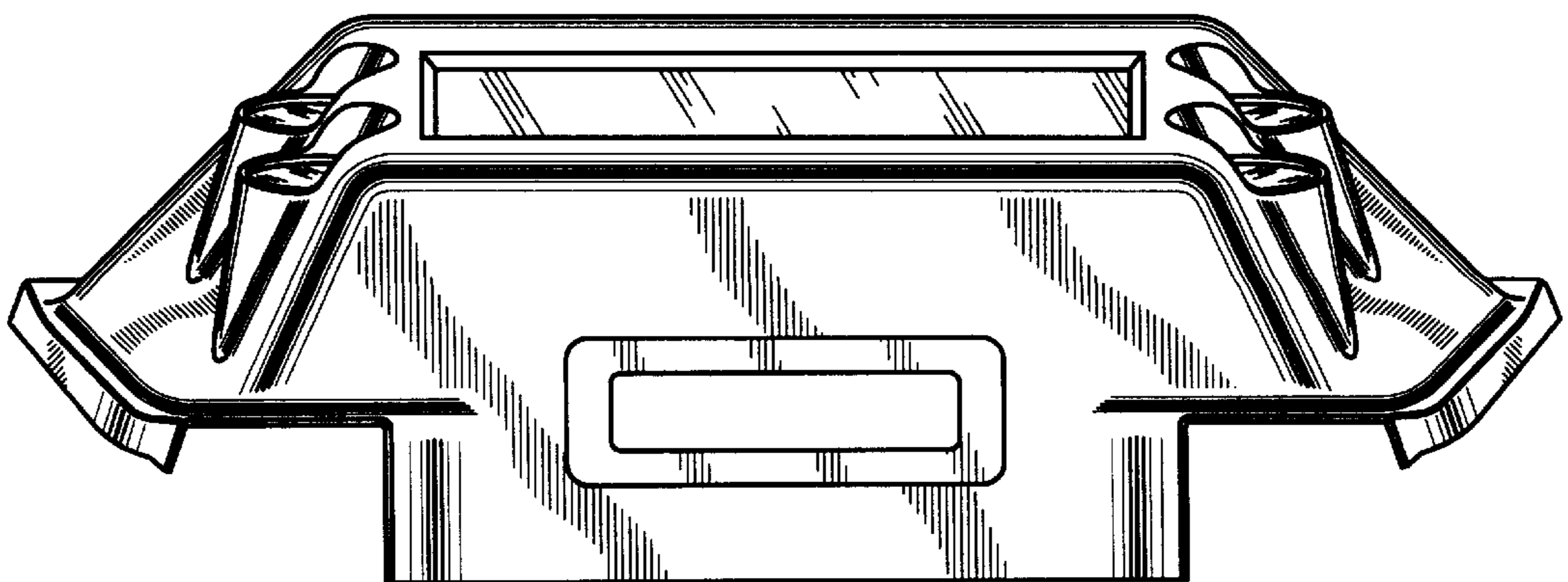

Fig.3

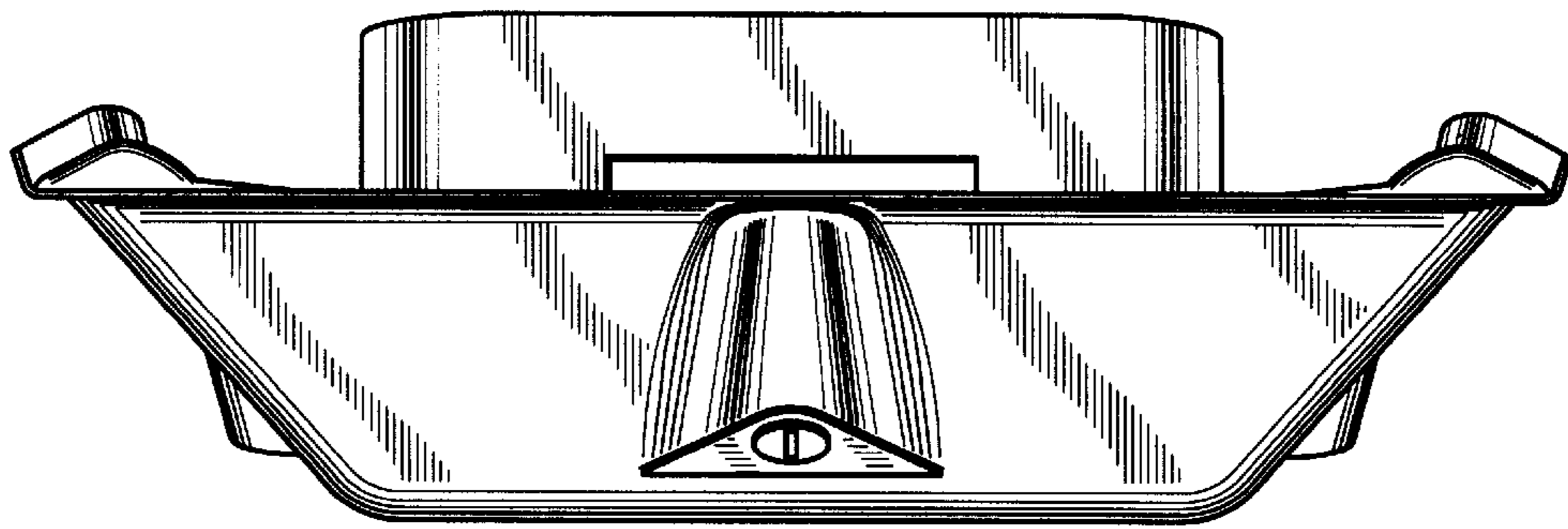

Fig.4

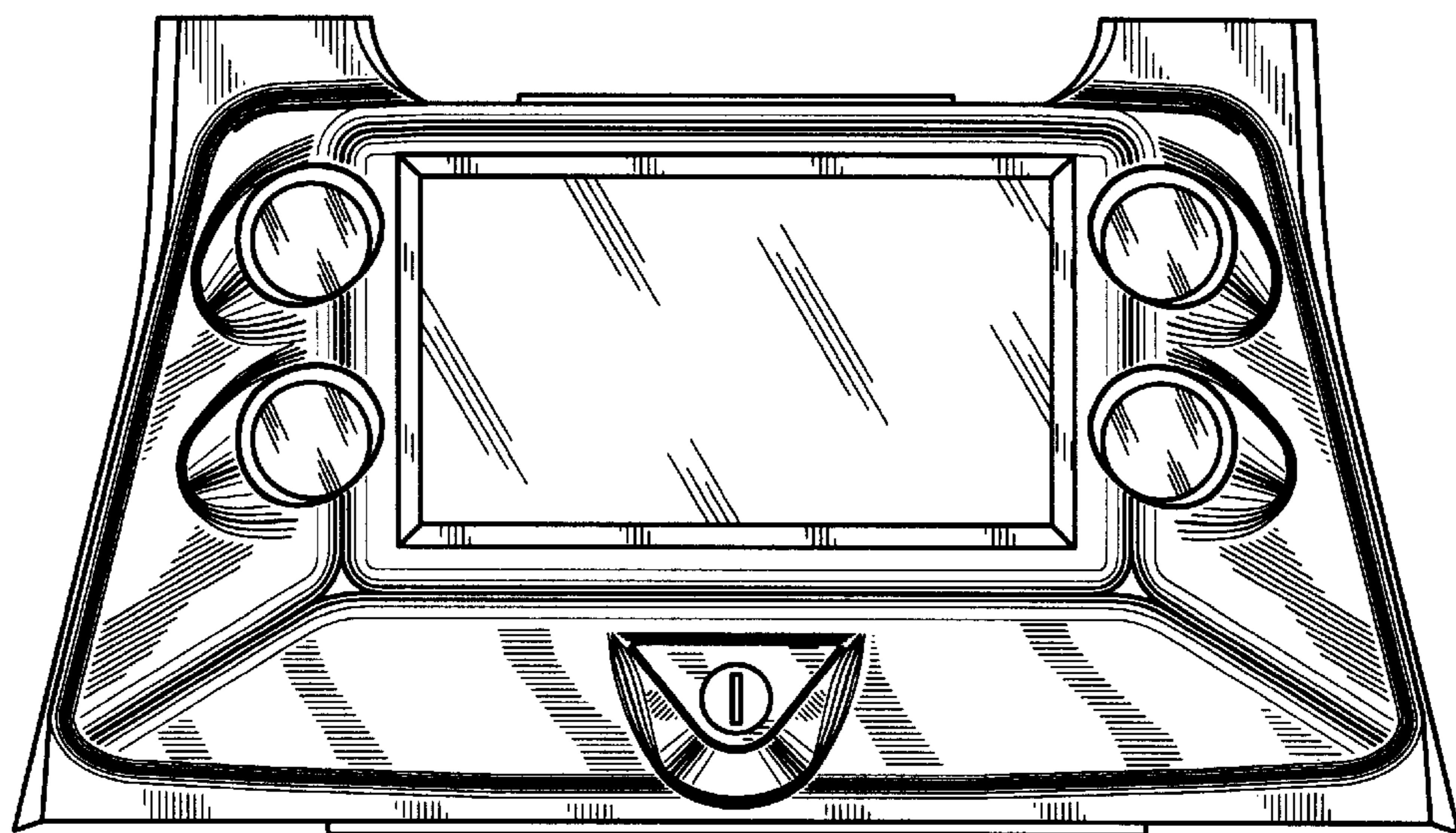

Fig.5

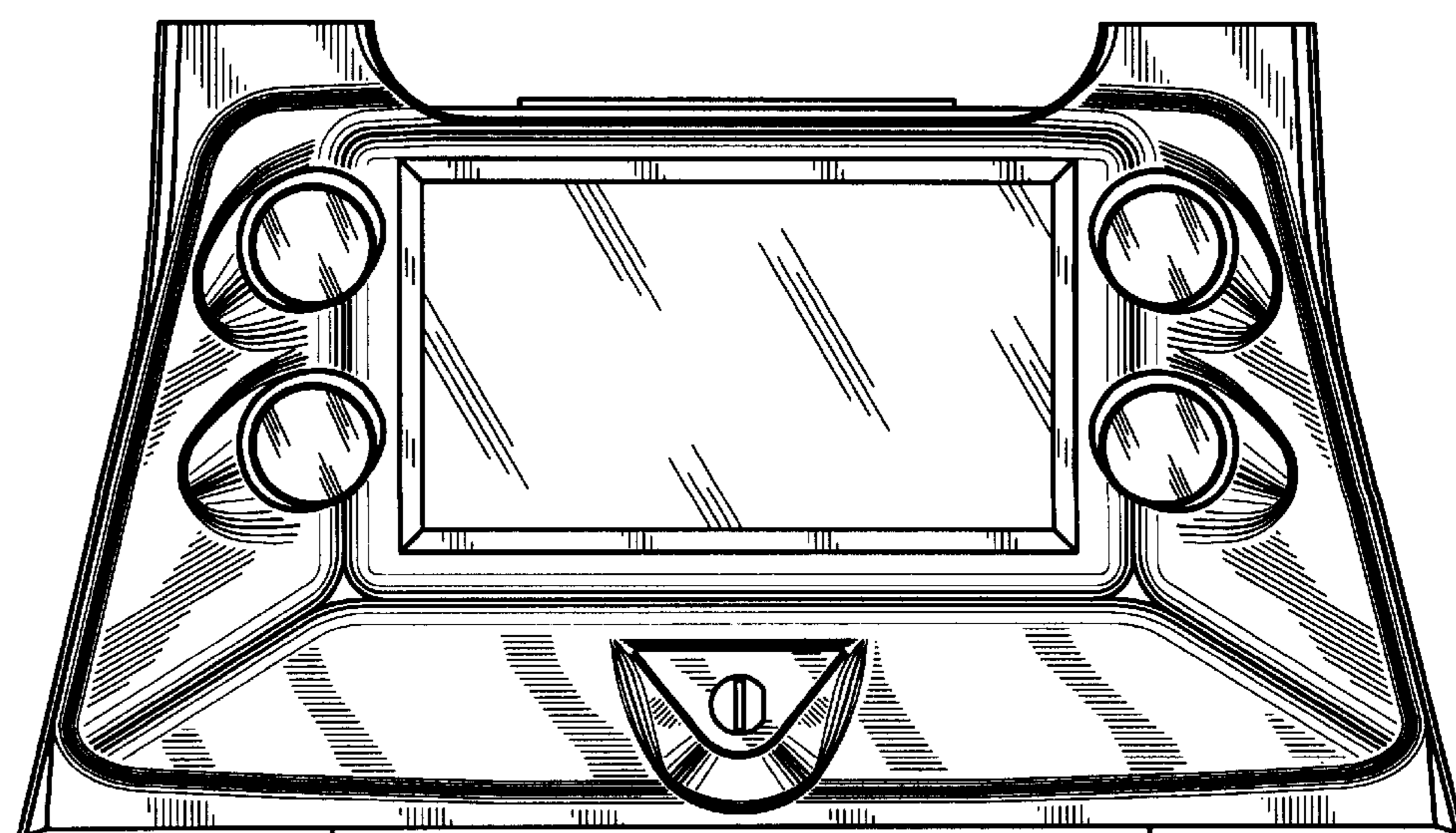

Fig.6

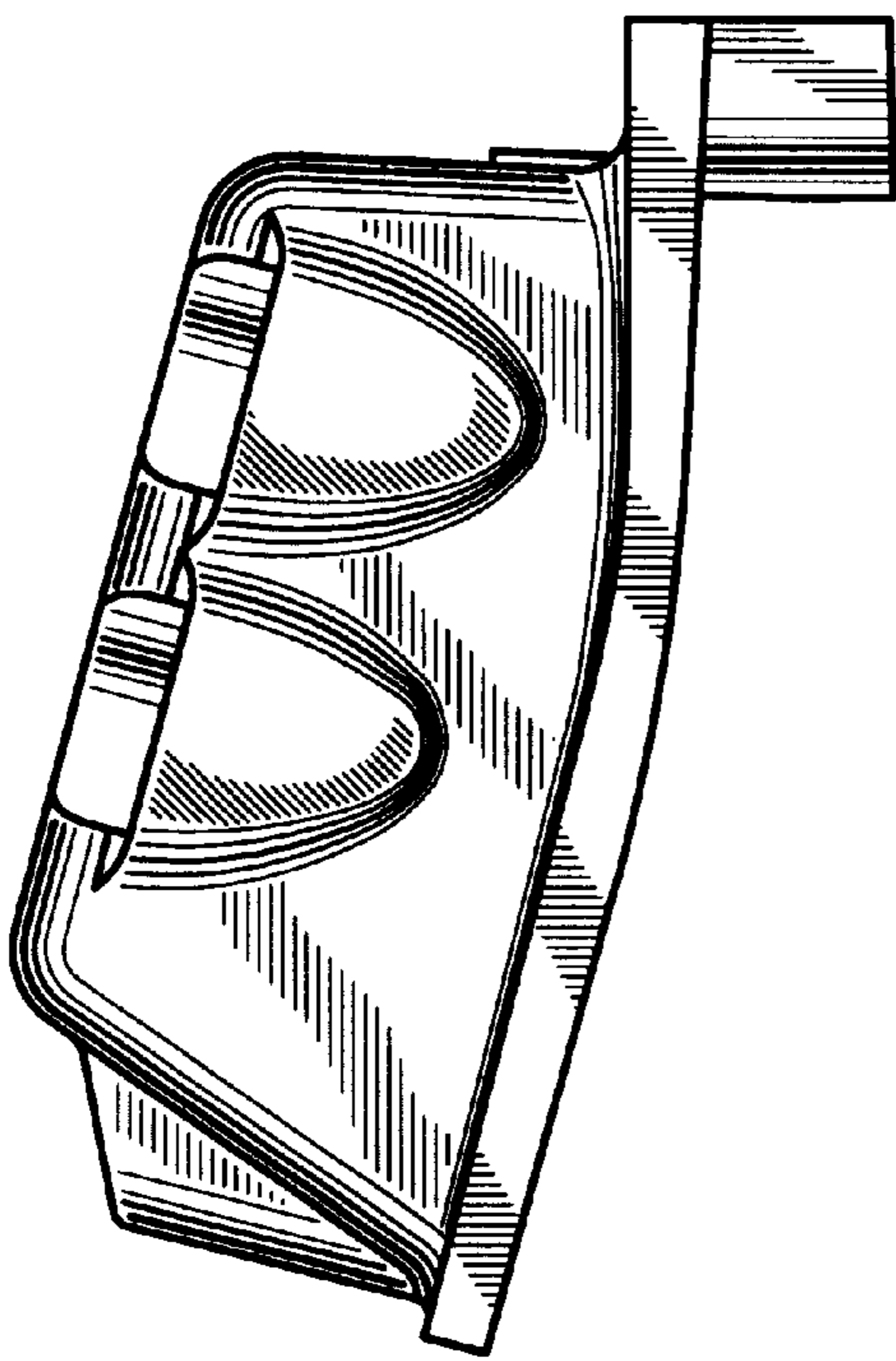

Fig.7

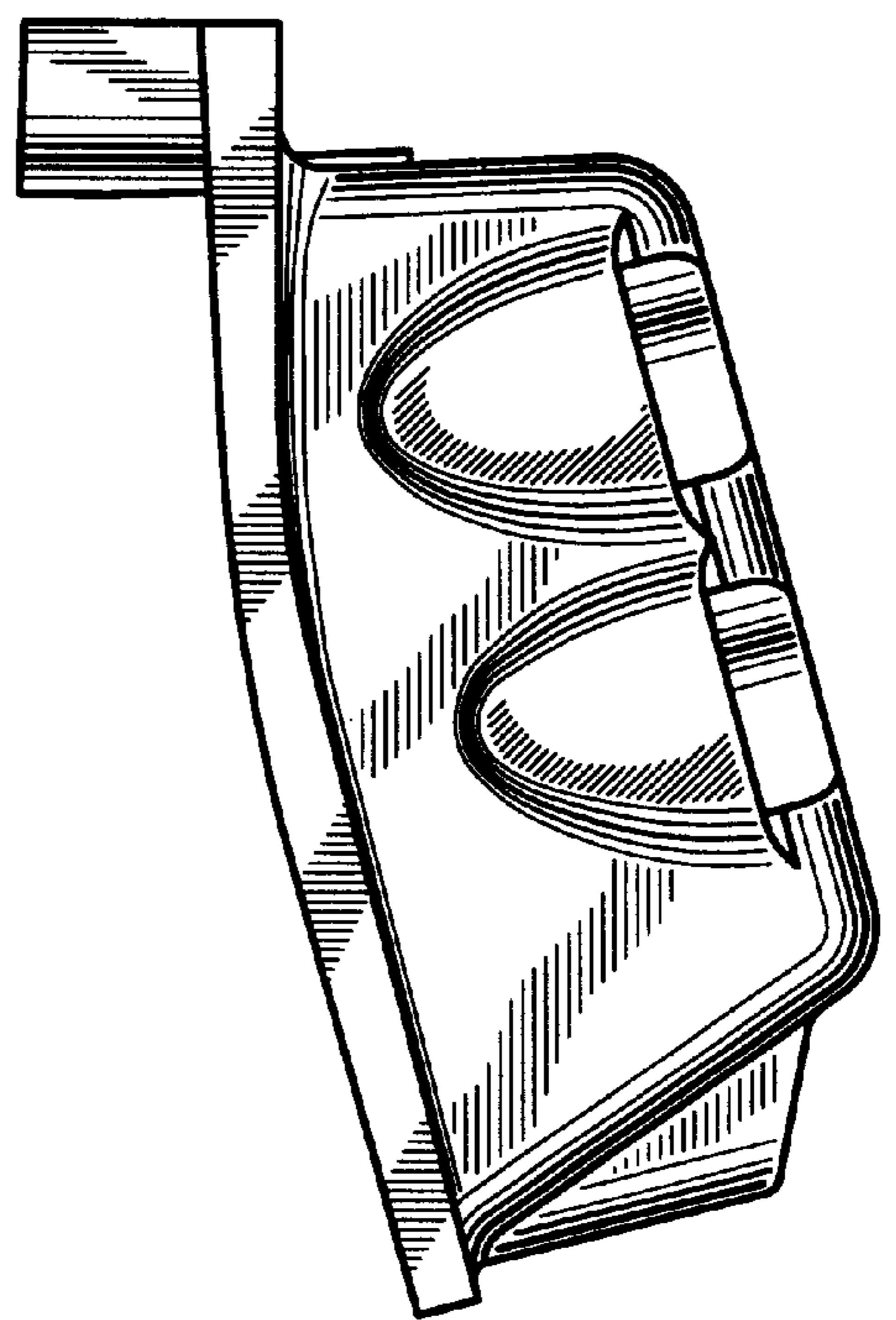

Fig.8