



US00D427965S

United States Patent [19]

Wu

[11] Patent Number: **Des. 427,965**

[45] Date of Patent: **** Jul. 11, 2000**

[54] **MOBILE PHONE BATTERY CHARGER WITH ELECTRICAL PLUG**

[75] Inventor: **Michael Wu, Hsin Tien, Taiwan**

[73] Assignee: **Formosa Electronic Industries Inc., Taiwan**

[**] Term: **14 Years**

[21] Appl. No.: **29/108,058**

[22] Filed: **Jul. 21, 1999**

[51] **LOC (7) Cl.** **13-02**

[52] **U.S. Cl.** **D13/107**

[58] **Field of Search** D13/107, 108;
D14/251, 253; 320/110-115

[56] **References Cited**

U.S. PATENT DOCUMENTS

D. 344,261	2/1994	Watanbe	D13/107
D. 357,224	4/1995	Nagele et al.	D13/107
D. 411,823	7/1999	Jacobs et al.	D13/107
5,525,888	6/1996	Toya	320/111
5,611,701	3/1997	Hahn	D13/107 X
5,648,712	7/1997	Hahn	320/111
5,691,618	11/1997	Kobayashi et al.	320/115
5,834,919	11/1998	Liu	320/111

Primary Examiner—Joel Sincavage
Attorney, Agent, or Firm—Dougherty & Troxell

[57] **CLAIM**

The ornamental design for a mobile phone battery charger with electrical plug, as shown and described.

DESCRIPTION

FIG. 1 is a perspective view of a mobile phone battery charger with dual electrical plug showing my new design; FIG. 2 is a front elevational view thereof; FIG. 3 is a rear elevational view thereof; FIG. 4 is a left side elevational view thereof; FIG. 5 is a right side elevational view thereof; FIG. 6 is a top plan view thereof; FIG. 7 is a bottom plan view thereof; FIG. 8 is a front, bottom, and right side perspective view thereof, showing that the primary plug and the secondary plug thereof are both at collapsed positions; FIG. 9 is a front, bottom, and right side perspective view thereof, showing that the primary plug thereof is at the collapsed position and the secondary plug thereof is at the erect position; and, FIG. 10 is a front, bottom, and right side perspective view thereof, showing that the primary plug and the secondary plug thereof are both at erect positions.

1 Claim, 7 Drawing Sheets

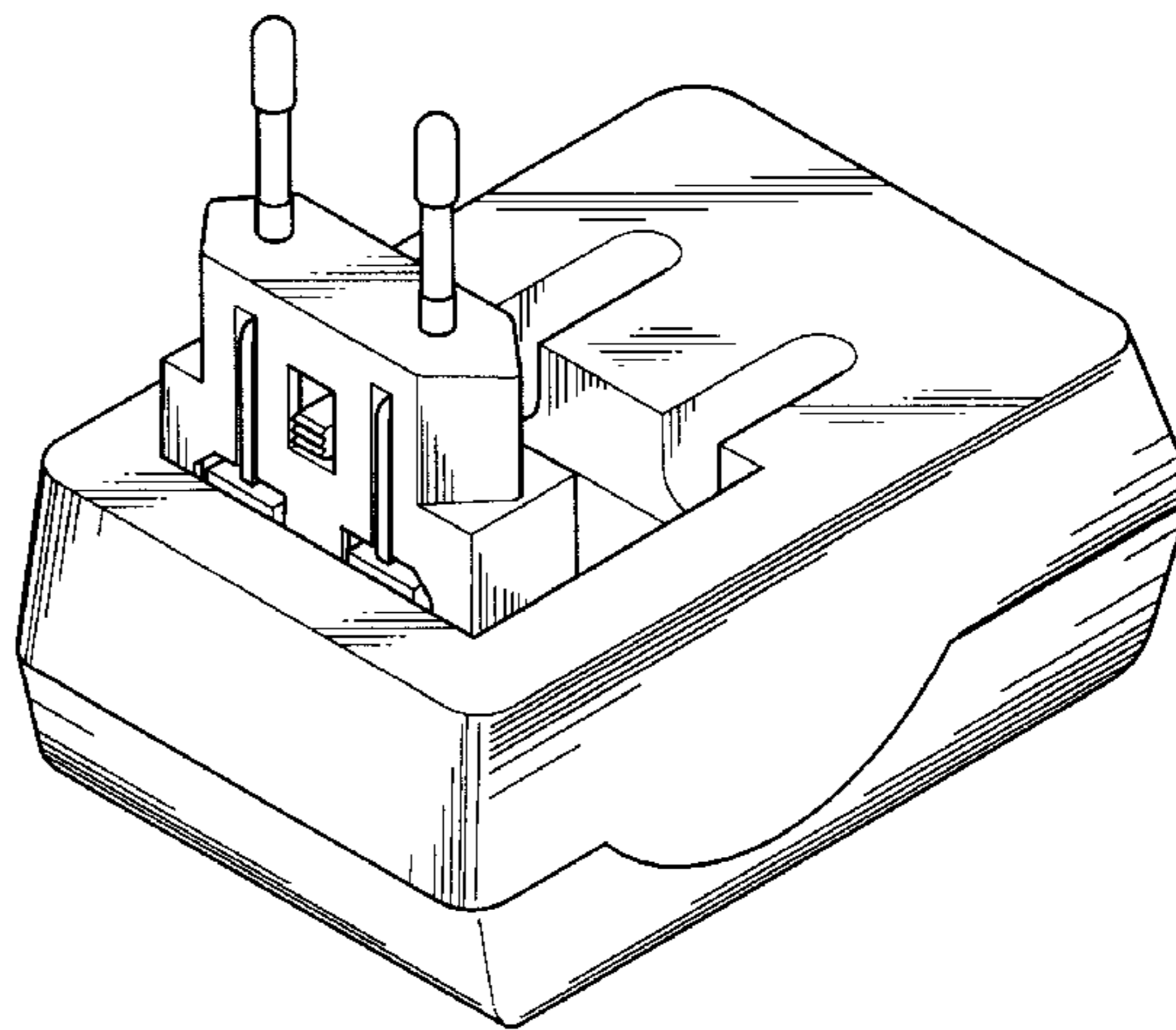
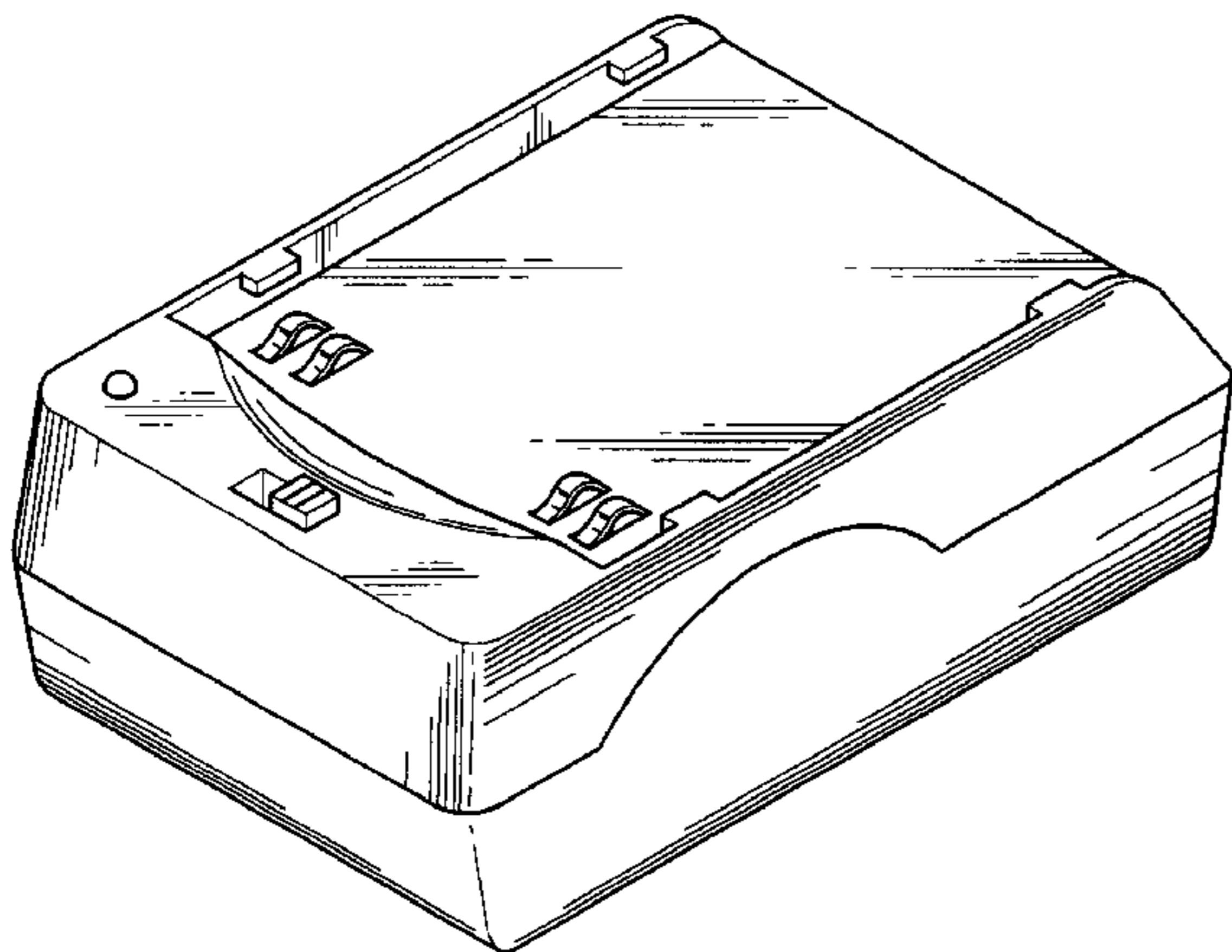

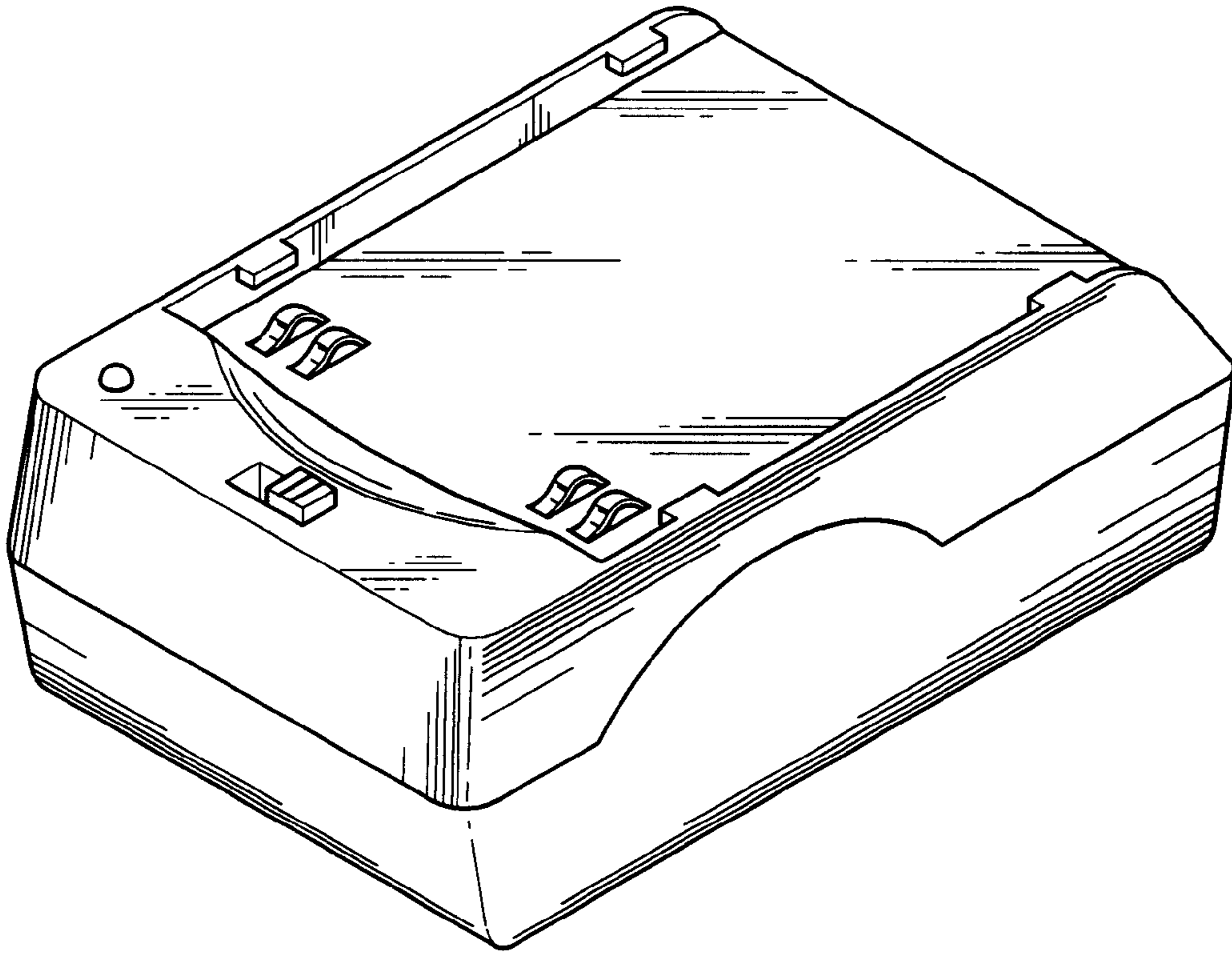

FIG. 1

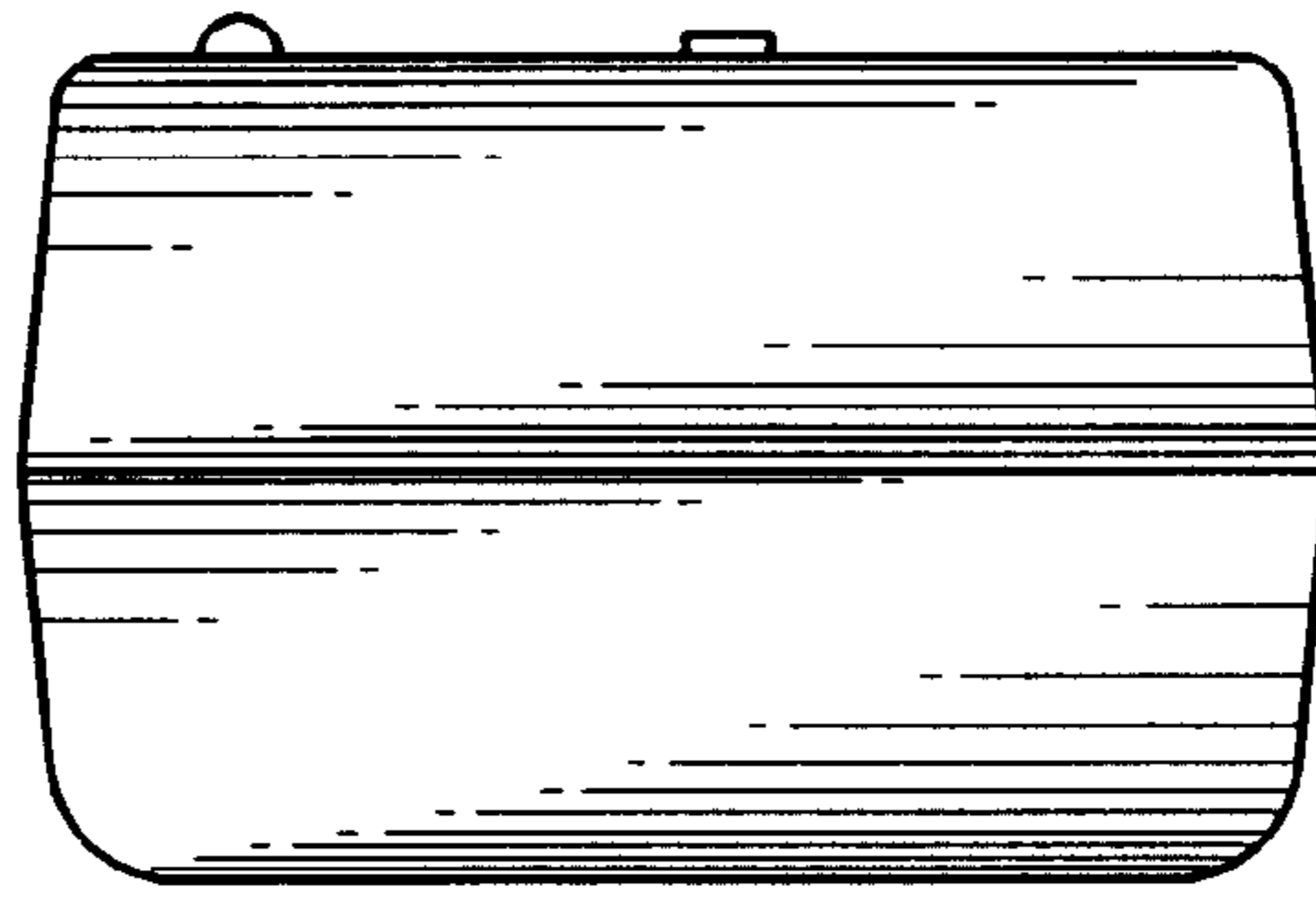

FIG. 2

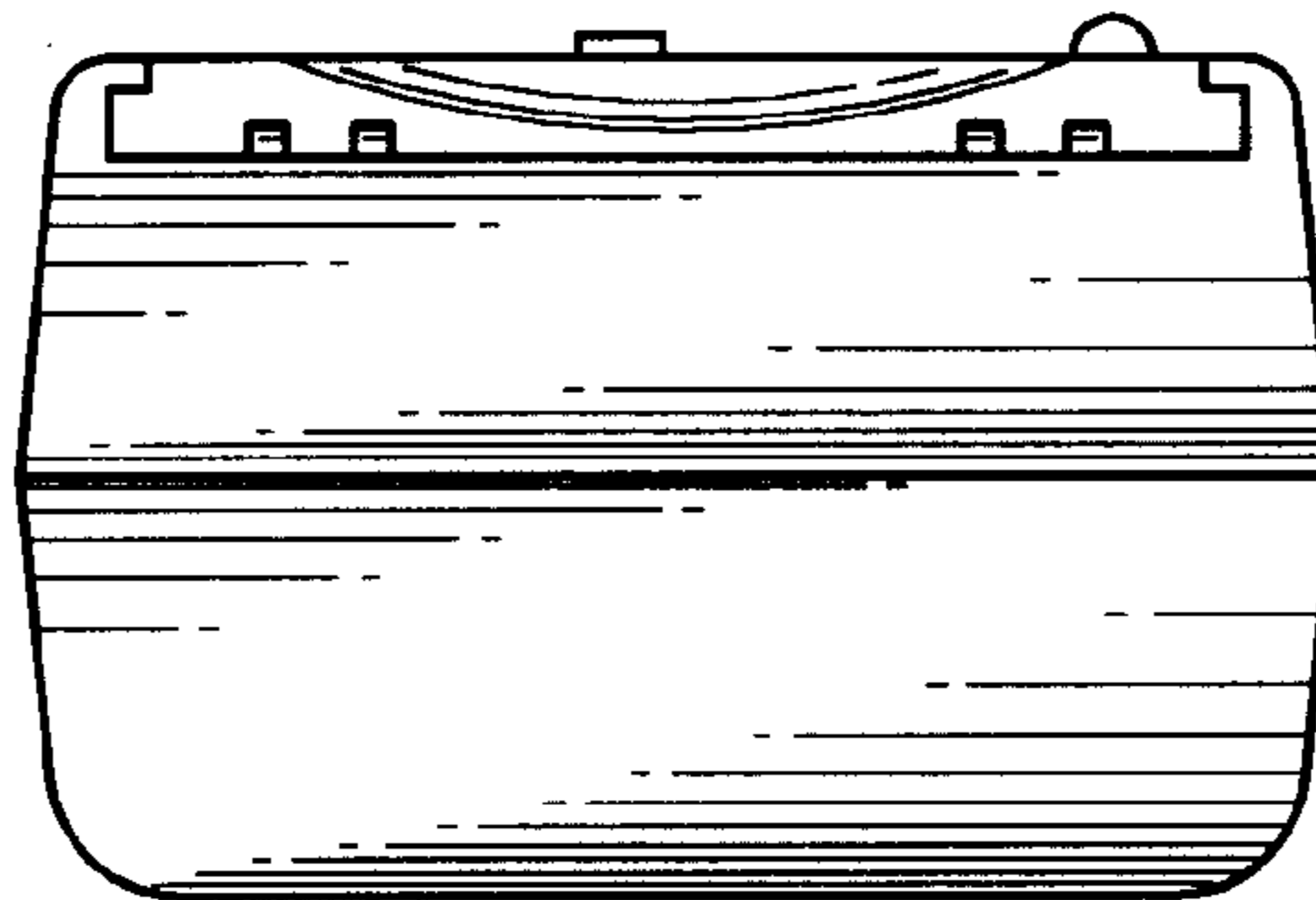

FIG. 3

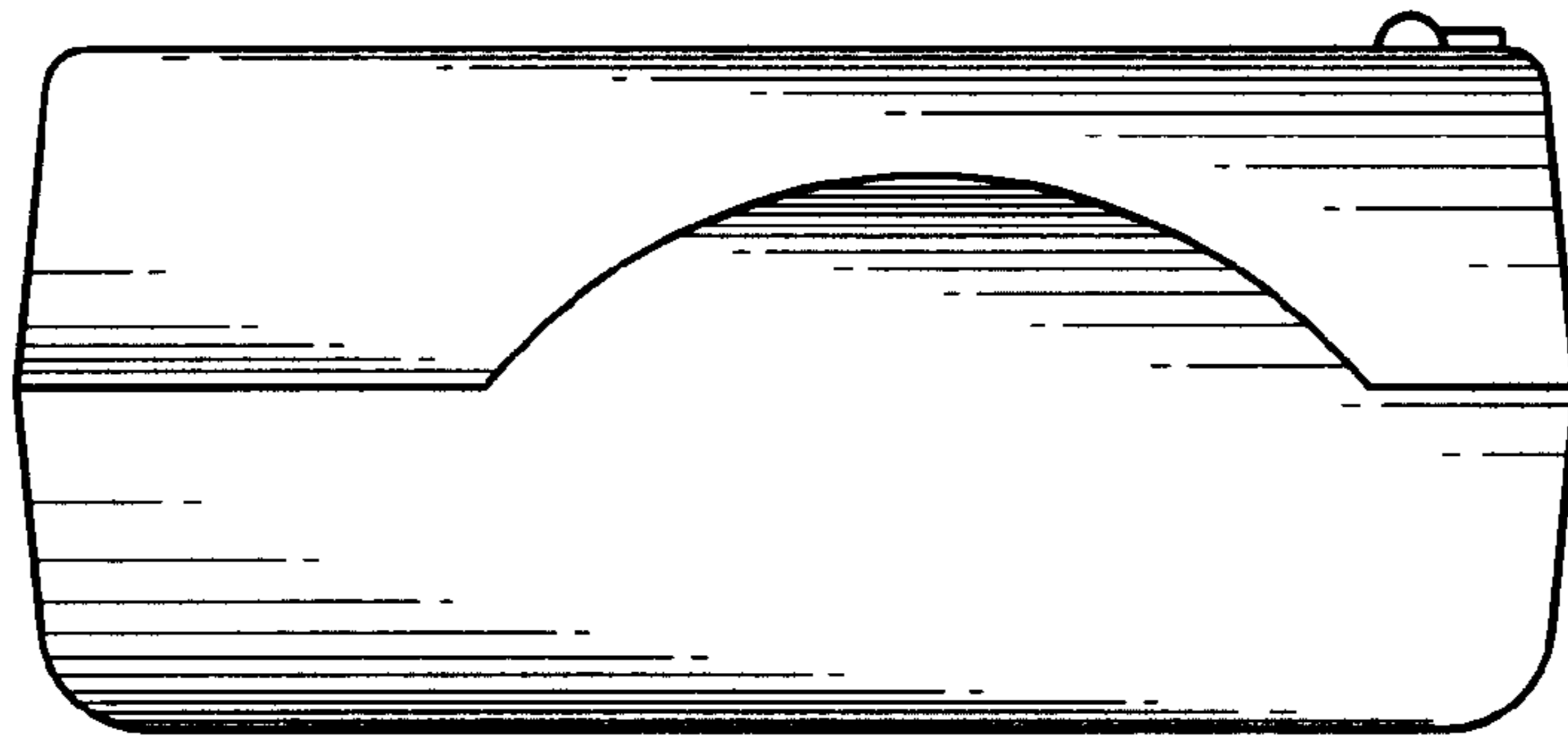

FIG. 4

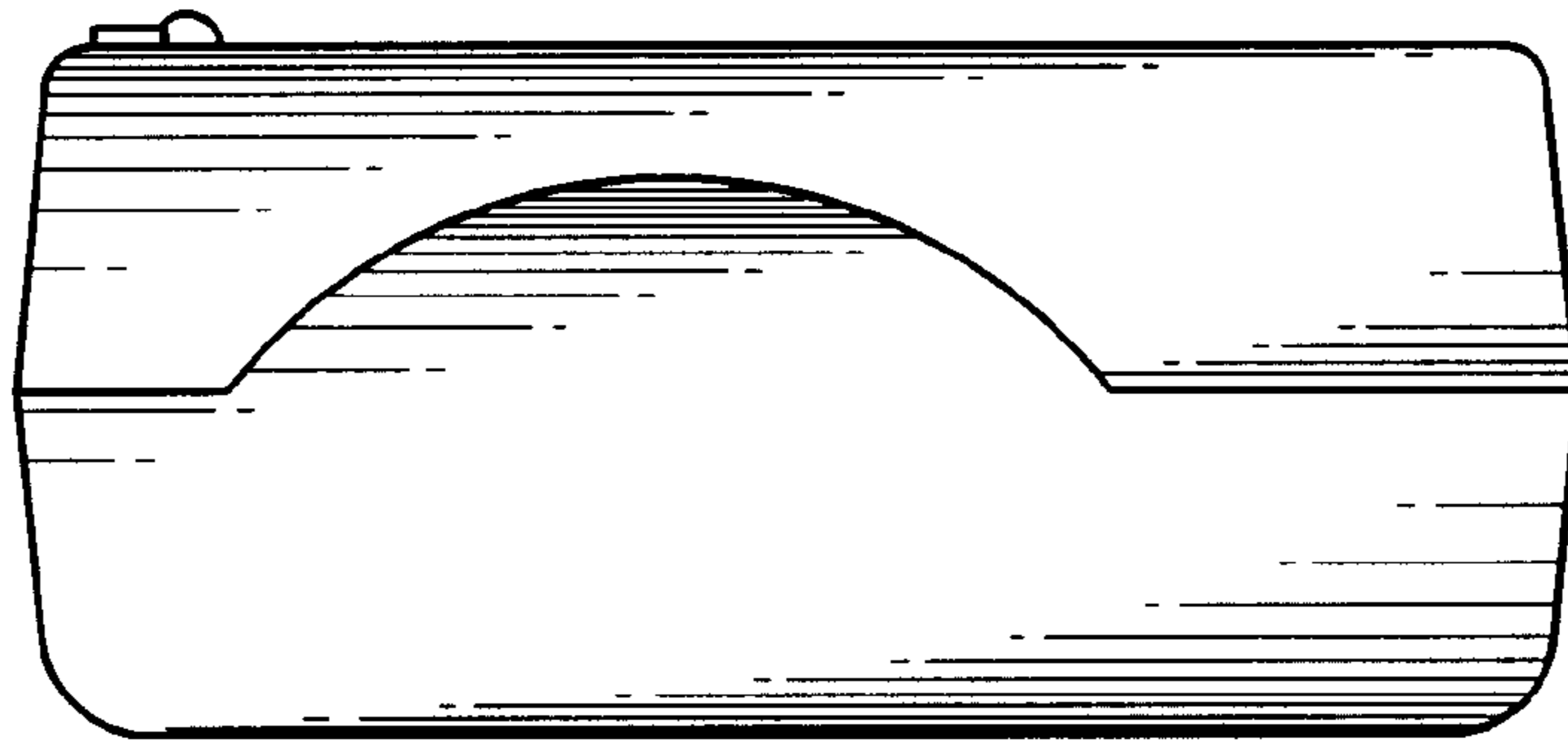

FIG. 5

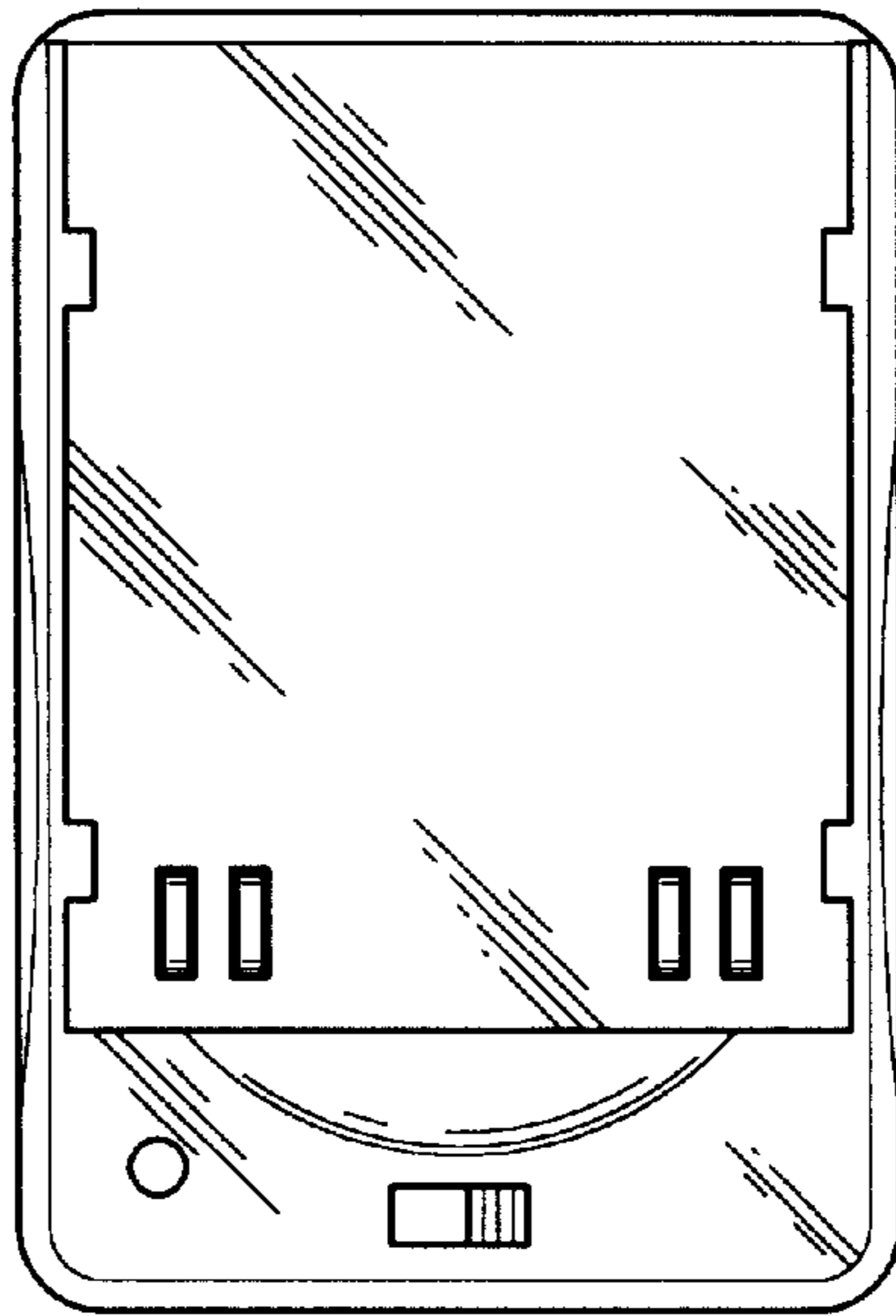

FIG. 6

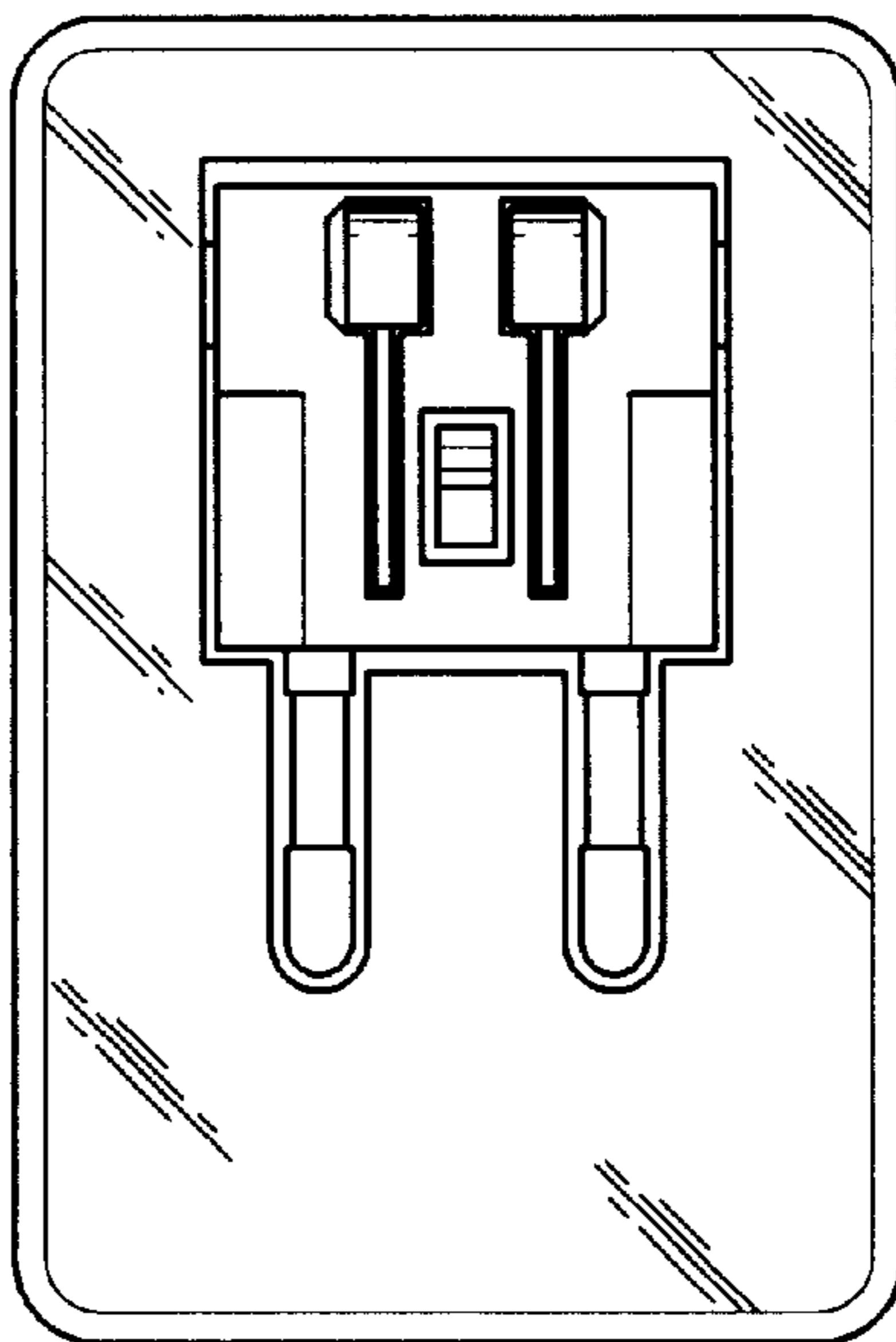

FIG. 7

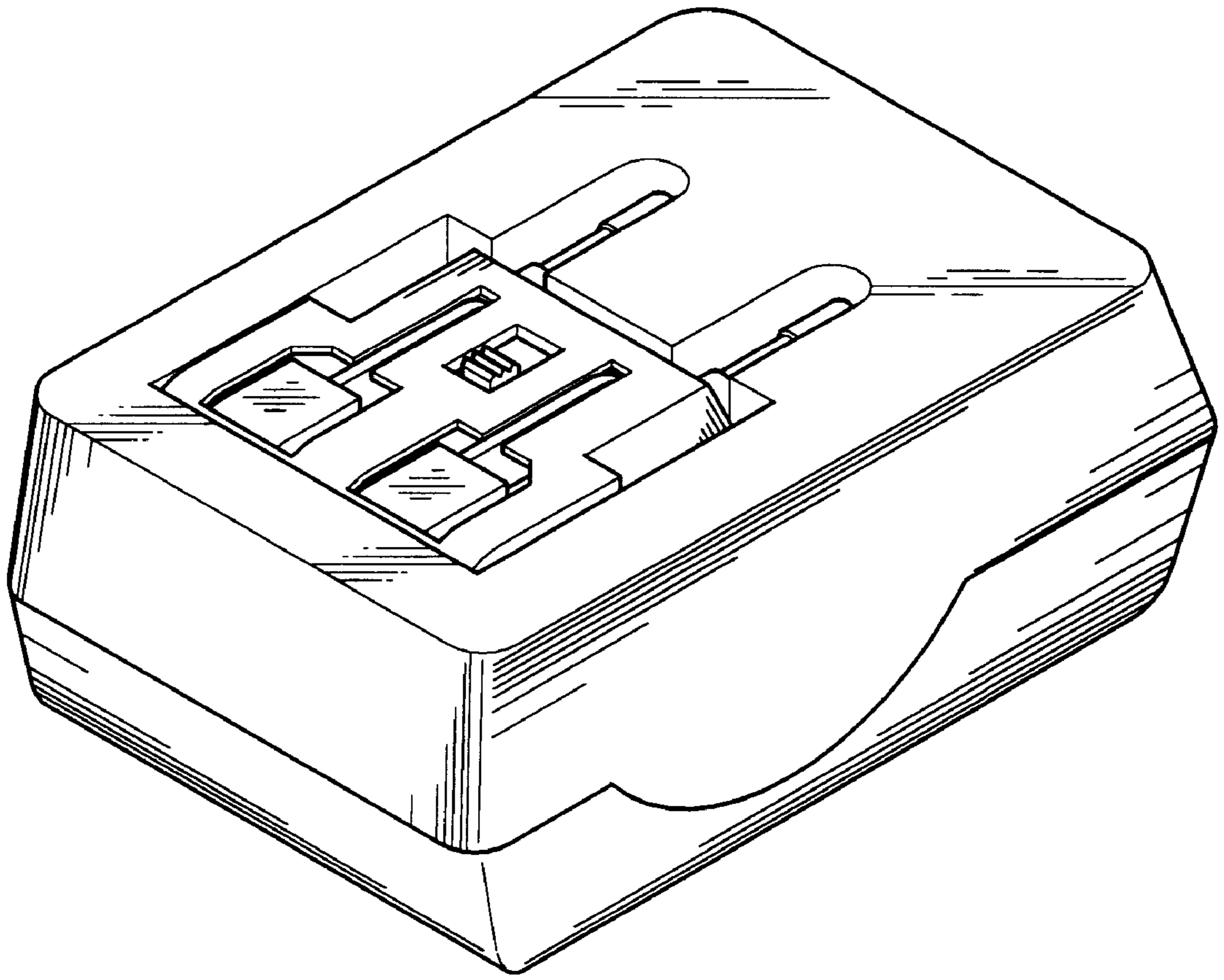

FIG. 8

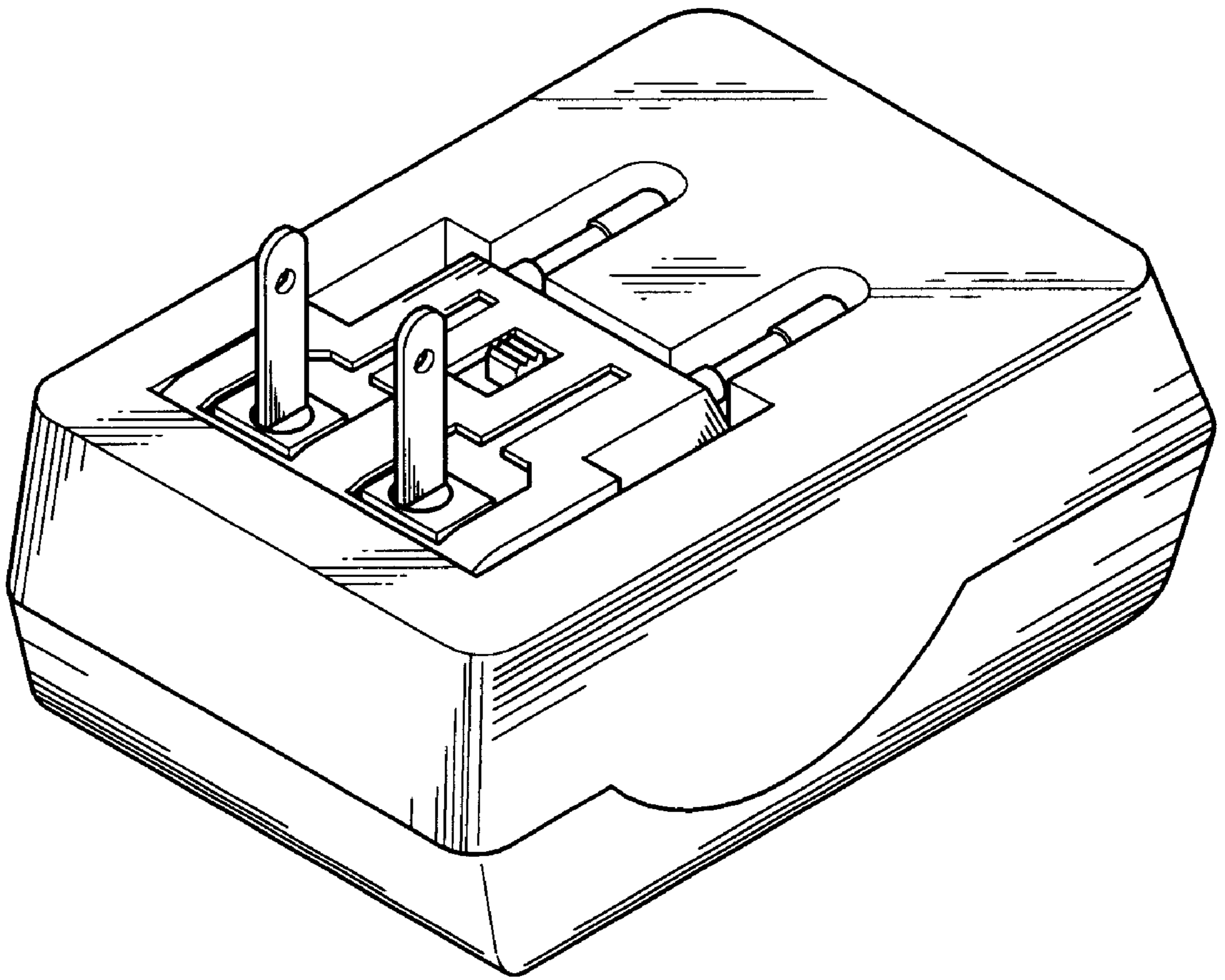

FIG. 9

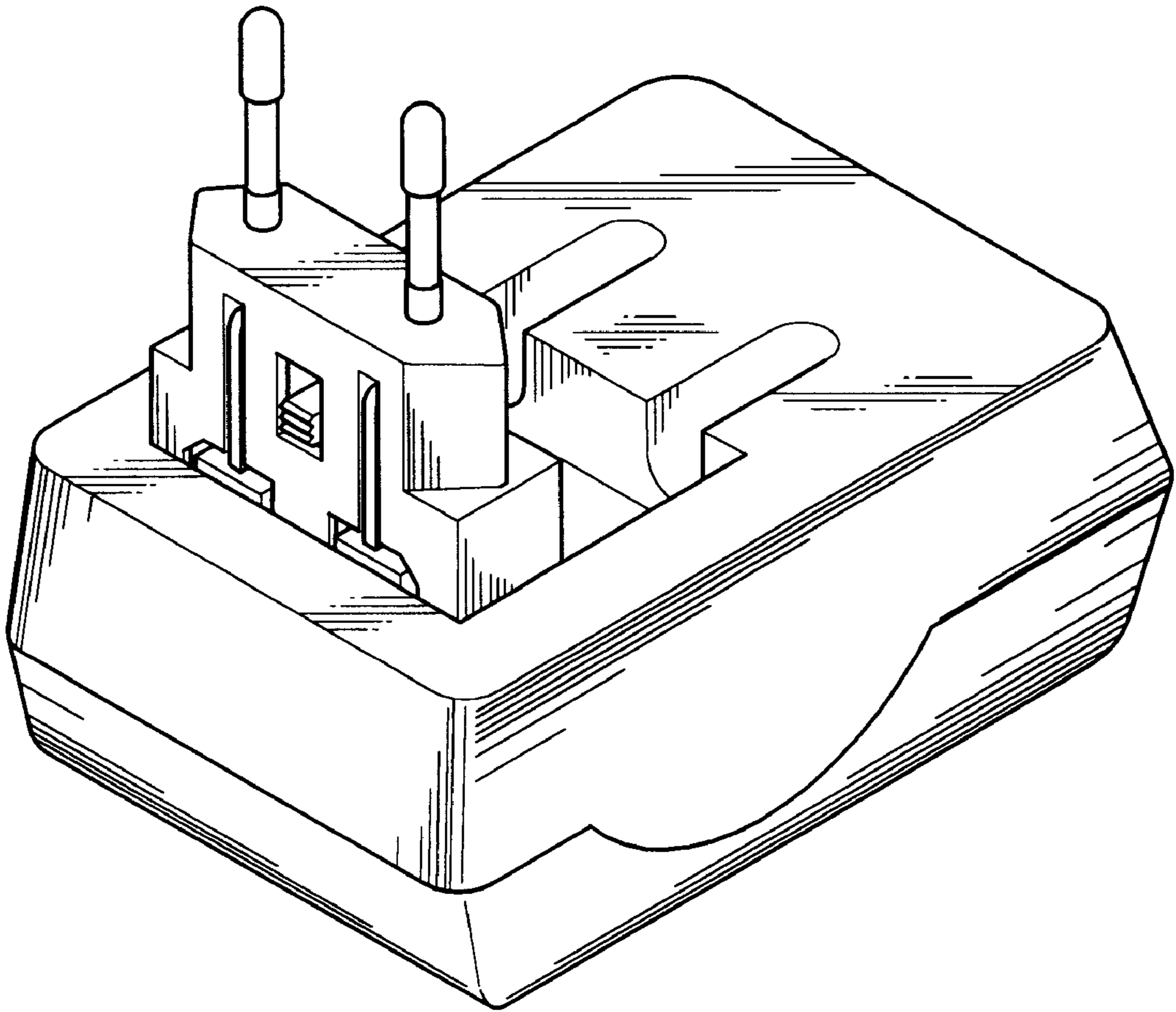

FIG. 10