



US00D427558S

# United States Patent [19] Neeper

[11] Patent Number: **Des. 427,558**

[45] Date of Patent: **\*\* Jul. 4, 2000**

[54] **VEHICLE-WHEEL FRONT FACE**

D. 412,480 8/1999 Hussaini et al. .... D12/209  
D. 417,646 12/1999 Baumgartner .... D12/211

[75] Inventor: **Mark D. Neeper**, Denver, Colo.

[73] Assignee: **Mobile Hi-Tech Wheels**, Torrance, Calif.

*Primary Examiner*—Stacia Cadmus  
*Attorney, Agent, or Firm*—Christie, Parker & Hale, LLP

[\*\*] Term: **14 Years**

[57] **CLAIM**

[21] Appl. No.: **29/112,512**

The ornamental design for a vehicle-wheel front face, as shown and described.

[22] Filed: **Oct. 18, 1999**

**DESCRIPTION**

[51] **LOC (7) Cl.** ..... **12-16**

[52] **U.S. Cl.** ..... **D12/211**

[58] **Field of Search** ..... D12/204-211;  
301/37.1, 64.1, 65

FIG. 1 is a perspective view of a vehicle-wheel front face according to my new design;  
FIG. 2 is an enlarged front elevational view thereof; and,  
FIG. 3 is an enlarged side elevational view thereof taken from the left side of FIG. 2, it being understood that the opposite side is a mirror image thereof.

Portions of the wheel depicted in broken line are for illustrative purposes only, and form no part of the claimed design.

[56] **References Cited**

**U.S. PATENT DOCUMENTS**

D. 286,037 10/1986 Walter ..... D12/211  
D. 387,320 12/1997 Niles ..... D12/211  
D. 390,822 2/1998 Neeper ..... D12/209

**1 Claim, 3 Drawing Sheets**

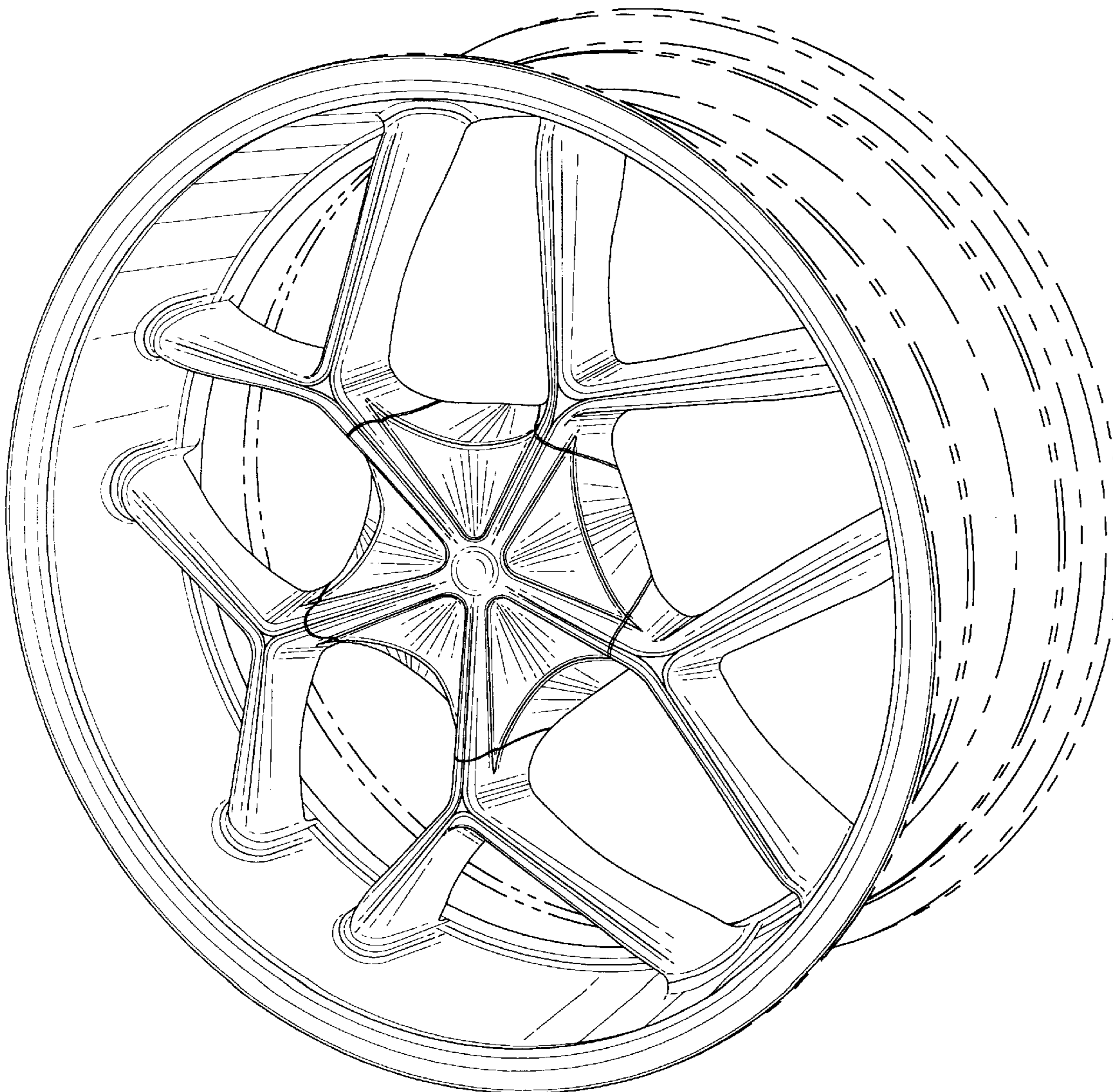

*FIG. 1*

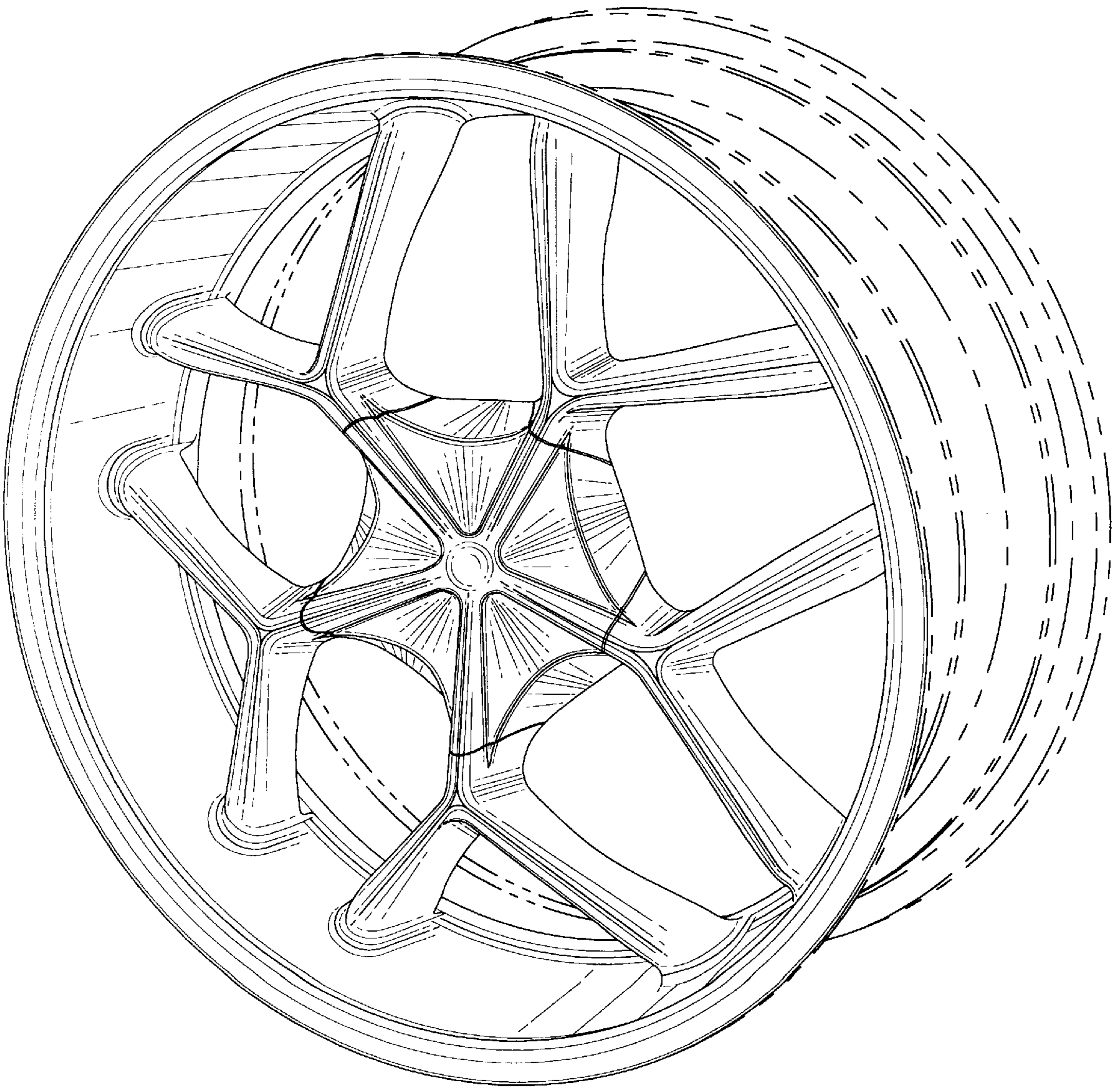

*FIG. 2*

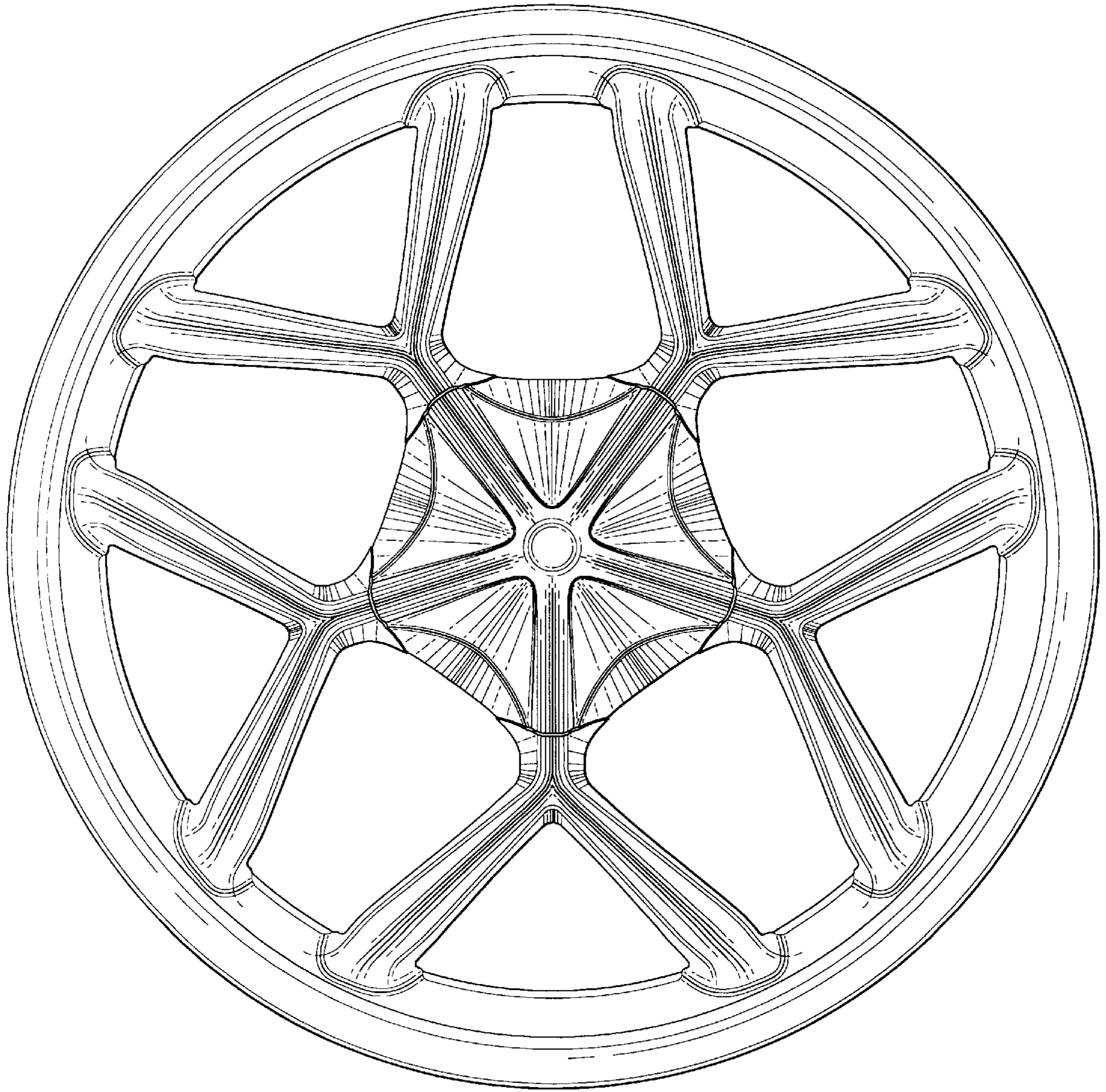

*FIG. 3*

