



US00D427548S

United States Patent [19]

[11] Patent Number: **Des. 427,548**

Sacco et al.

[45] Date of Patent: **** Jul. 4, 2000**

[54] **AUTOMOBILE**

[75] Inventors: **Bruno Sacco**, Sindelfingen; **Michael Kraemer**, Notzingen; **Guenter Hoelzel**, Hochdorf; **Harald Leschke**, Sindelfingen; **Uwe Haller**, Marbach am Neckar, all of Germany

[73] Assignee: **DaimlerChrysler AG**, Germany

[**] Term: **14 Years**

[21] Appl. No.: **29/078,789**

[22] Filed: **Nov. 3, 1997**

[30] **Foreign Application Priority Data**

May 2, 1997 [DE] Germany M 97 04 207

[51] **LOC (7) Cl.** **12-08**

[52] **U.S. Cl.** **D12/85**

[58] **Field of Search** D12/85, 86, 88;
296/185; 180/210, 215, 217, 65.1

[56] **References Cited**

U.S. PATENT DOCUMENTS

- D. 329,211 9/1992 Malewuki D12/85
- D. 404,688 1/1999 Hanagan D12/85
- D. 407,348 3/1999 Riley D12/85
- 5,460,234 10/1995 Matsuura et al. 180/65.1

Primary Examiner—Melody N. Brown
Attorney, Agent, or Firm—Evenson, McKeown, Edwards & Lenahan, P.L.L.C.

[57] **CLAIM**

The ornamental design for an automobile, as shown and described.

DESCRIPTION

FIG. 1 is a front-left perspective view of an automobile with the top on according to our novel design;
 FIG. 2 is a right side view of the automobile of FIG. 1;
 FIG. 3 is a left side view of the automobile of FIG. 1;
 FIG. 4 is a front view of the automobile of FIG. 1;
 FIG. 5 is a rear view of the automobile of FIG. 1;
 FIG. 6 is a right-rear perspective view of the automobile of FIG. 1;
 FIG. 7 is a left-rear perspective view of the automobile of FIG. 1;
 FIG. 8 is a top view of the automobile of FIG. 1;
 FIG. 9 is a bottom view of the automobile of FIG. 1;
 FIG. 10 is a front-left perspective view of the automobile of FIG. 1 with the top removed;
 FIG. 11 is a right side view of the automobile of FIG. 10;
 FIG. 12 is a left side view of the automobile of FIG. 10;
 FIG. 13 is a front view of the automobile of FIG. 10;
 FIG. 14 is a rear view of the automobile of FIG. 10;
 FIG. 15 is a right-rear perspective view of the automobile of FIG. 10;
 FIG. 16 is a left-rear perspective view of the automobile of FIG. 10; and,
 FIG. 17 is a top plan view of the automobile of FIG. 10.
 The broken lines are for illustration only and form no part of the claimed design.

1 Claim, 10 Drawing Sheets

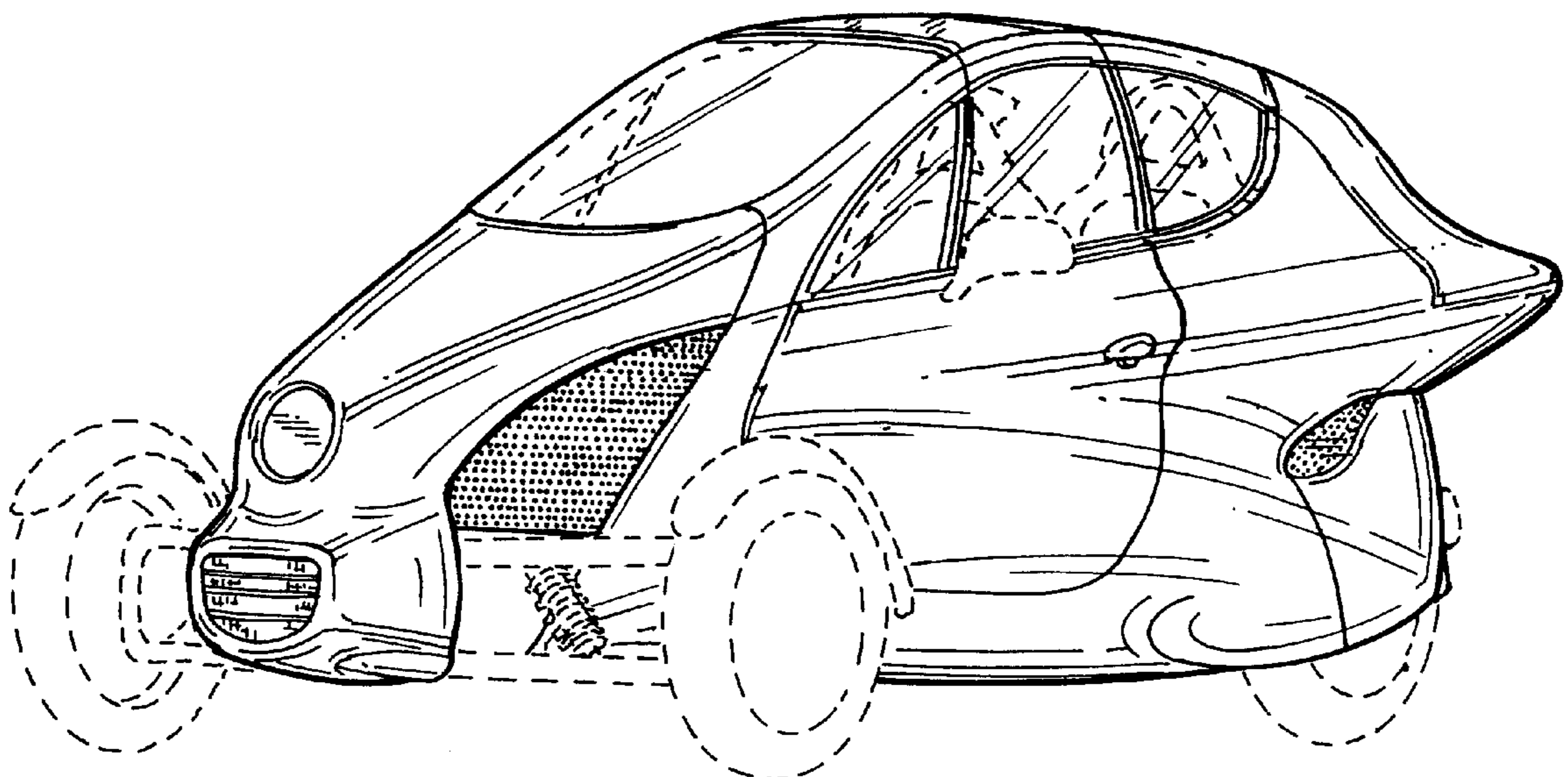

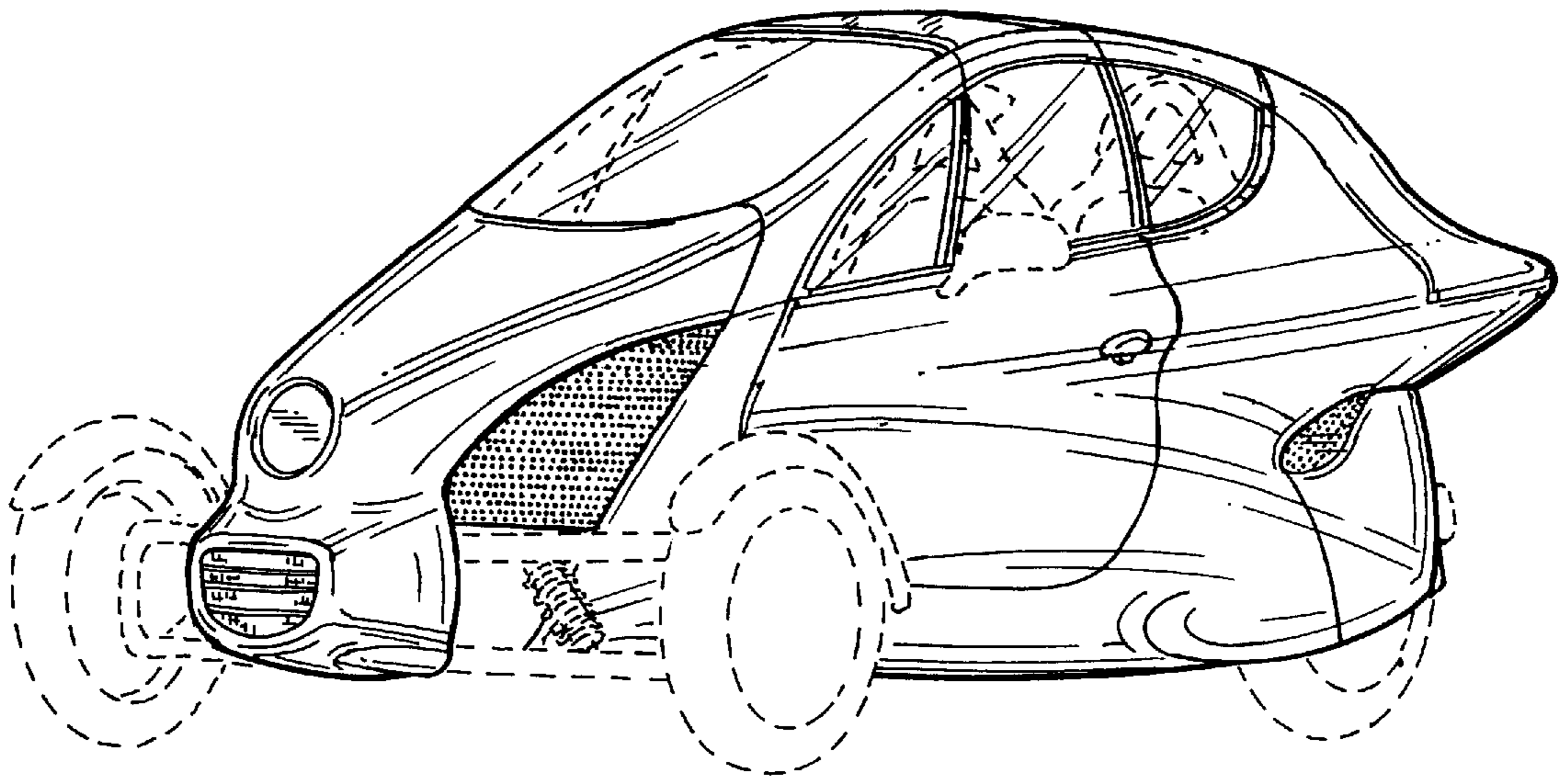

FIG. 1

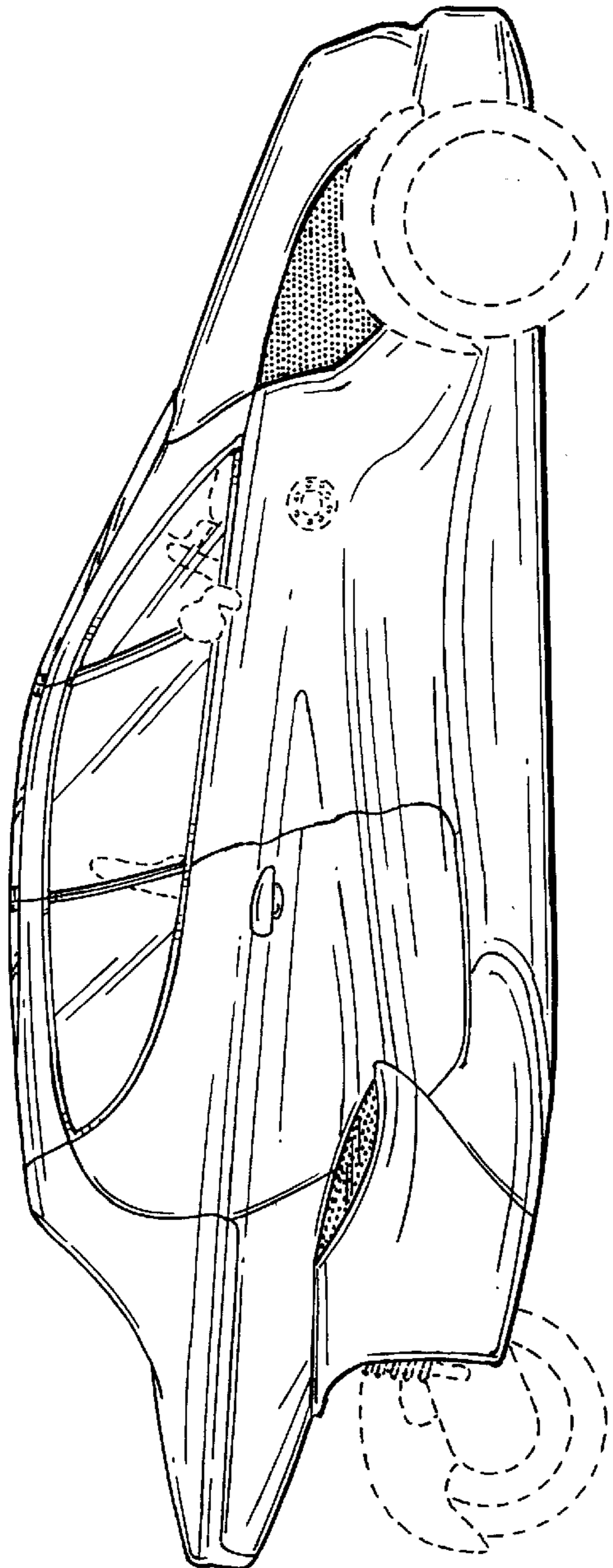

FIG. 2

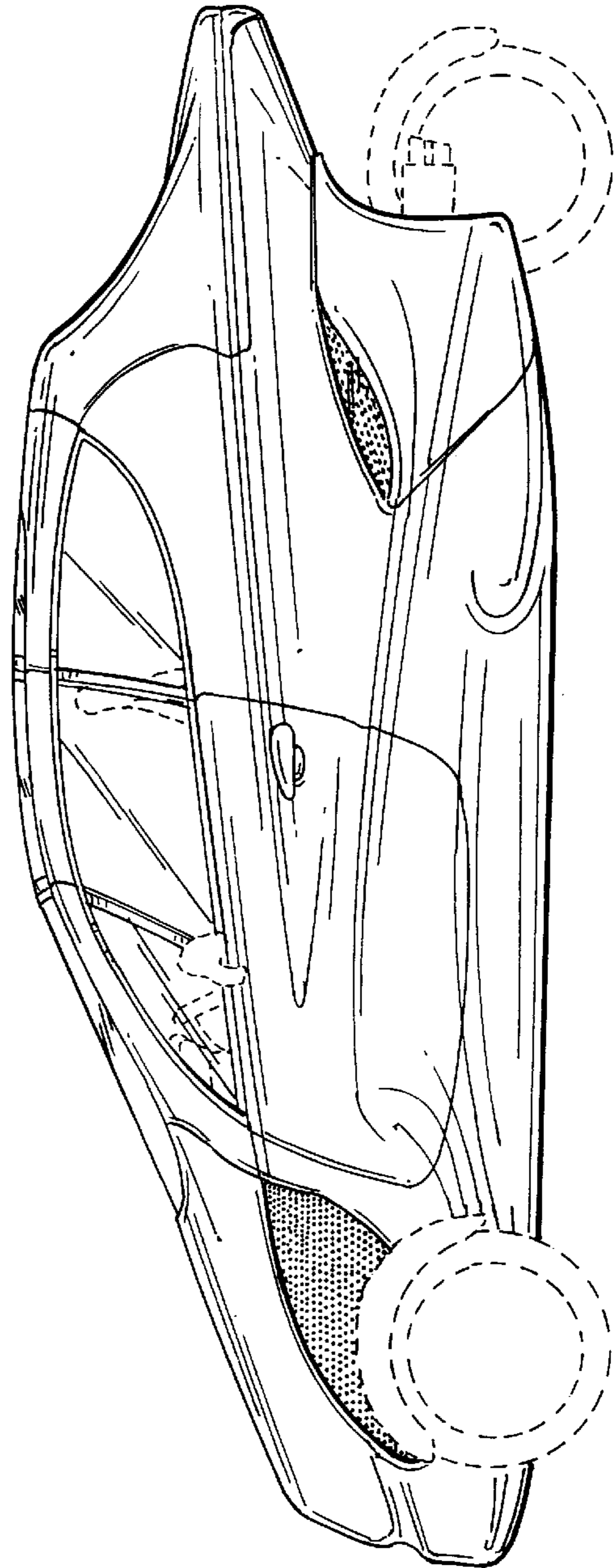

FIG. 3

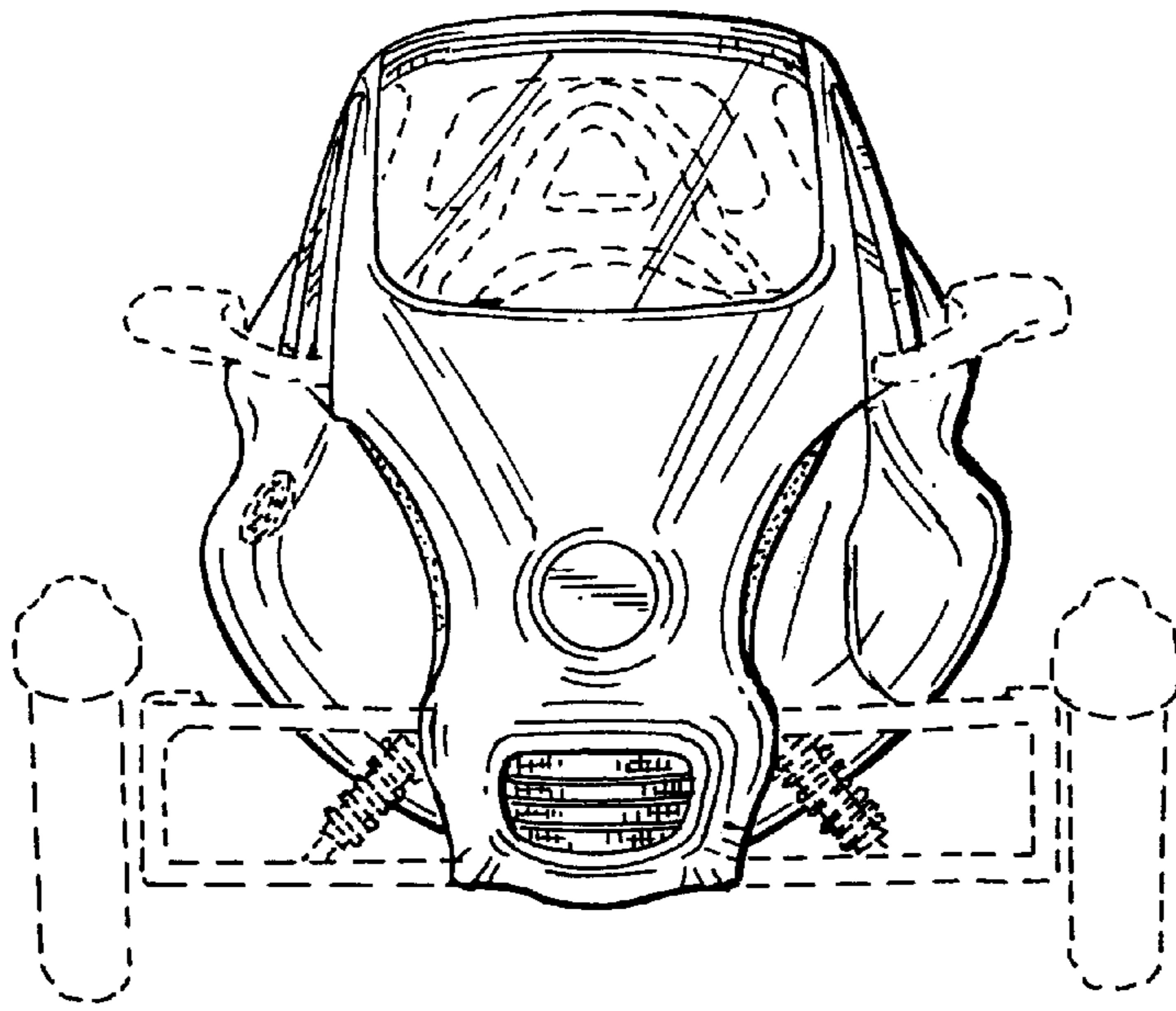

FIG. 4

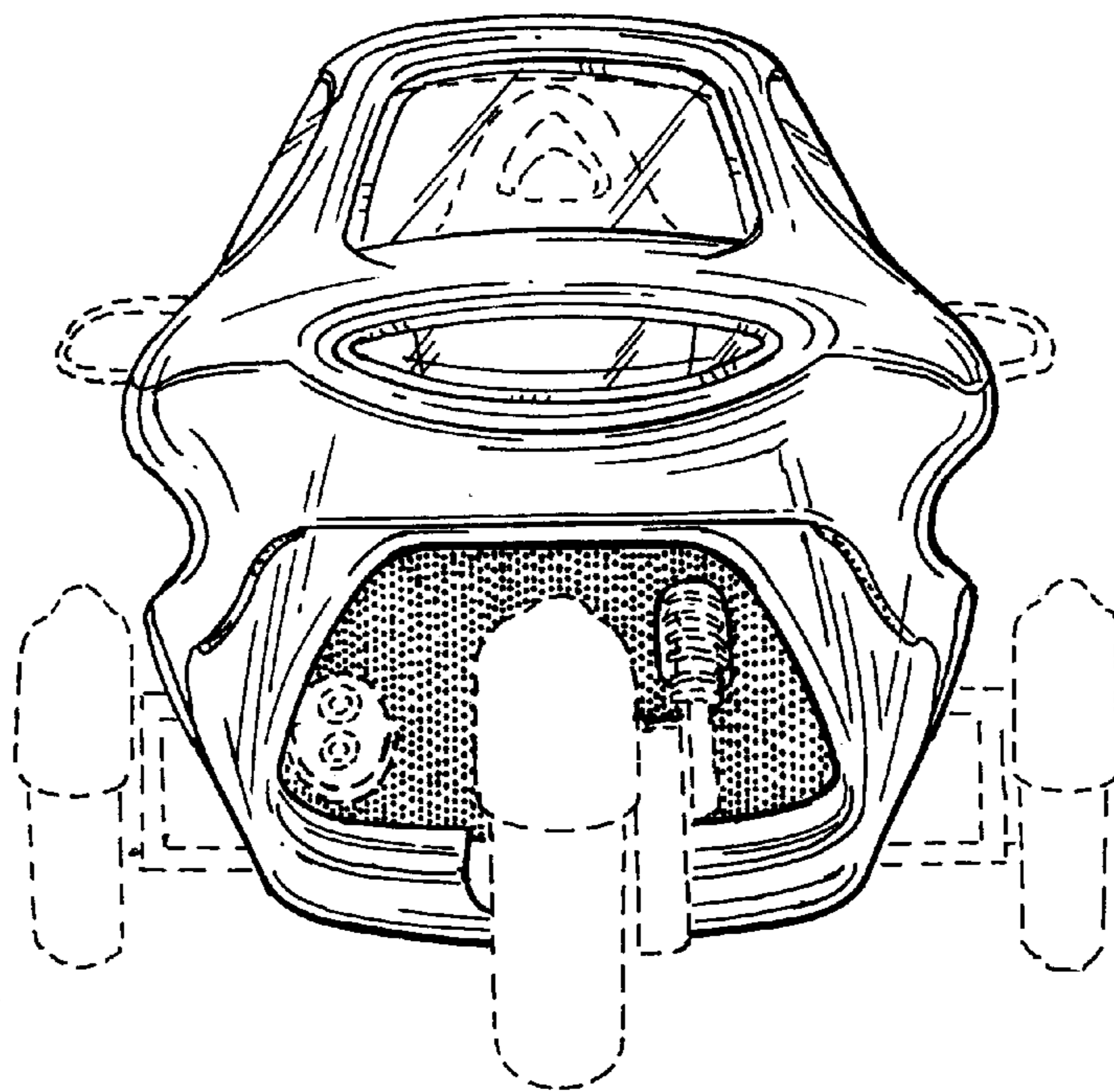

FIG. 5

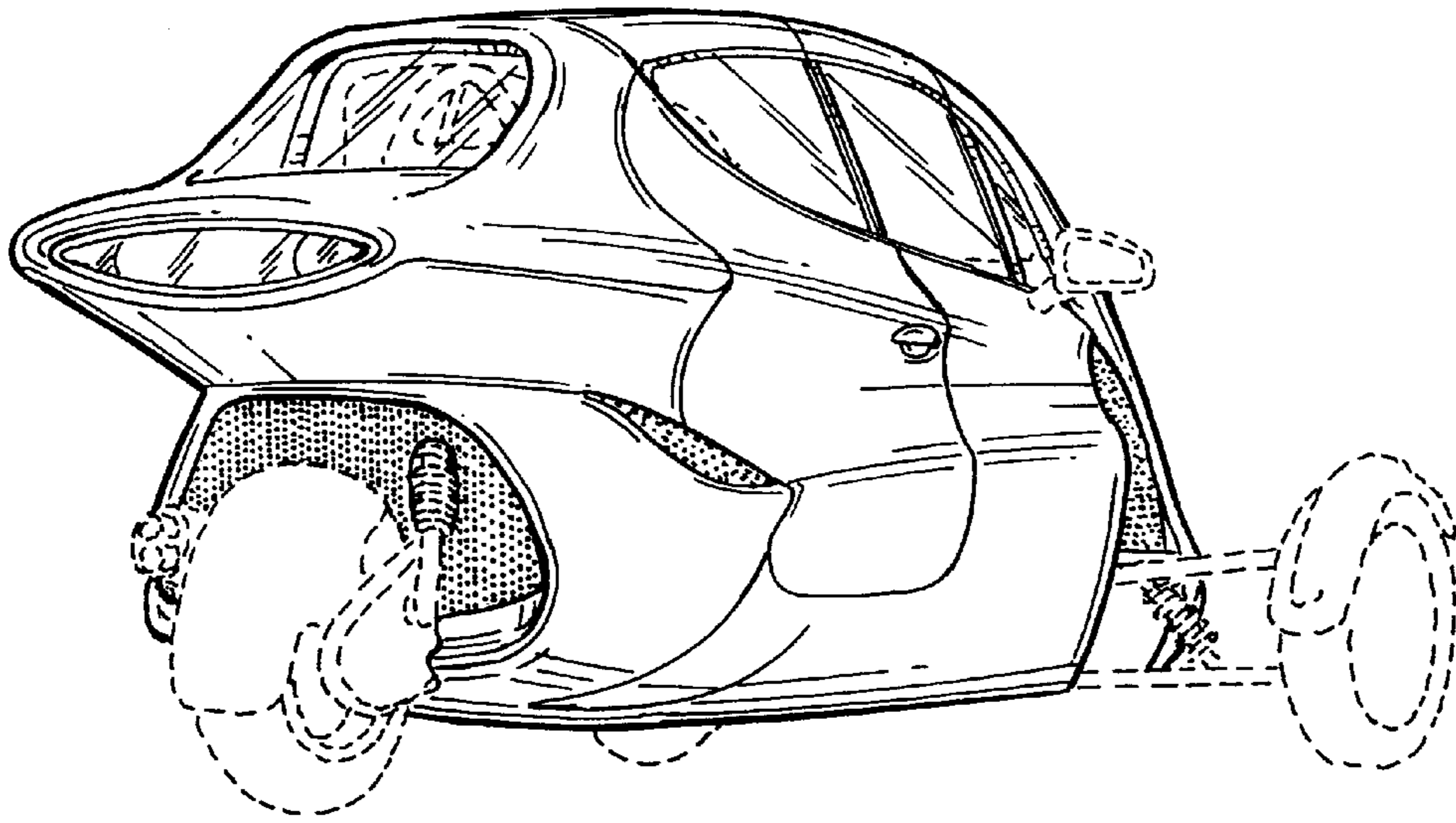

FIG. 6

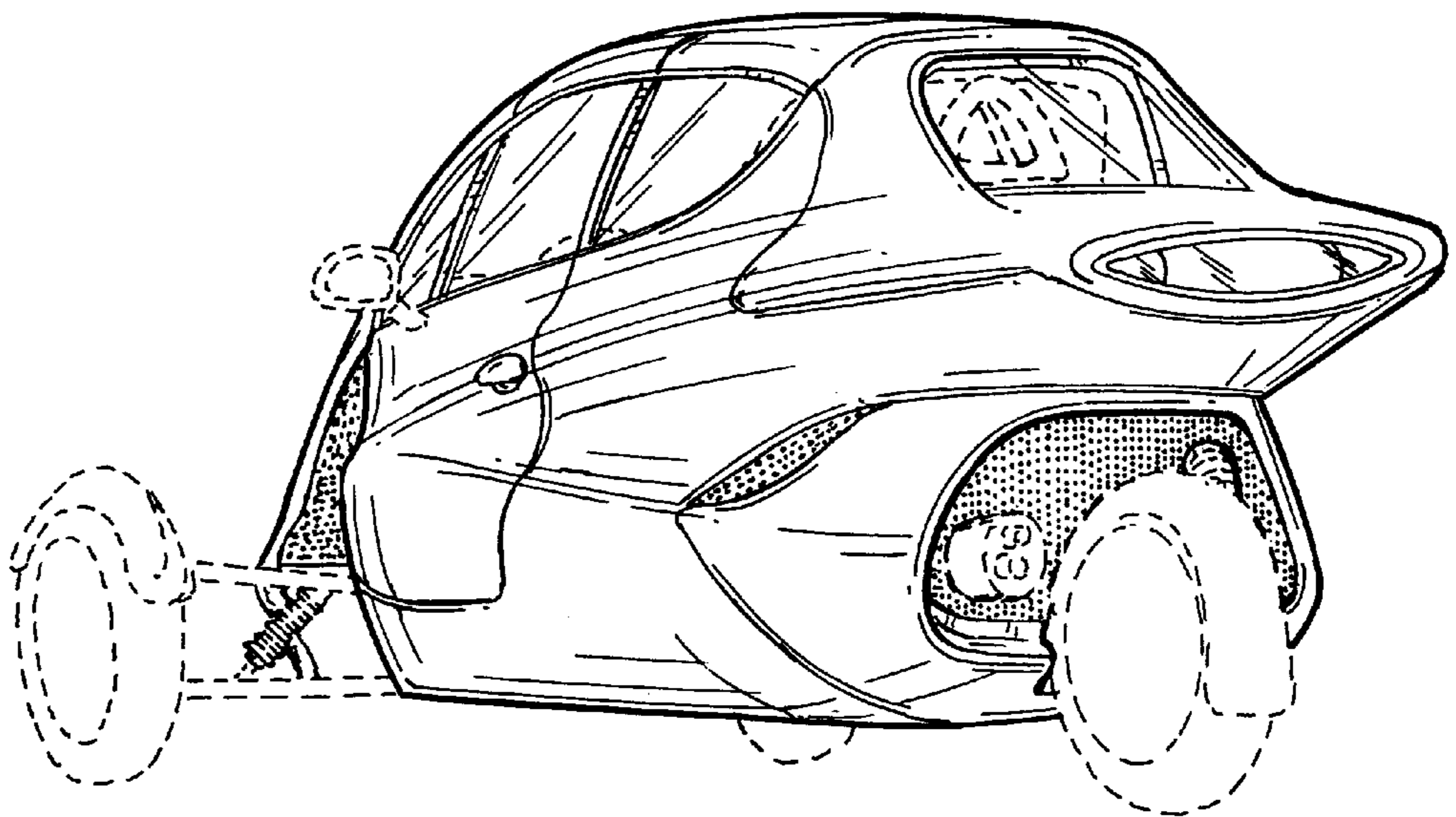

FIG. 7

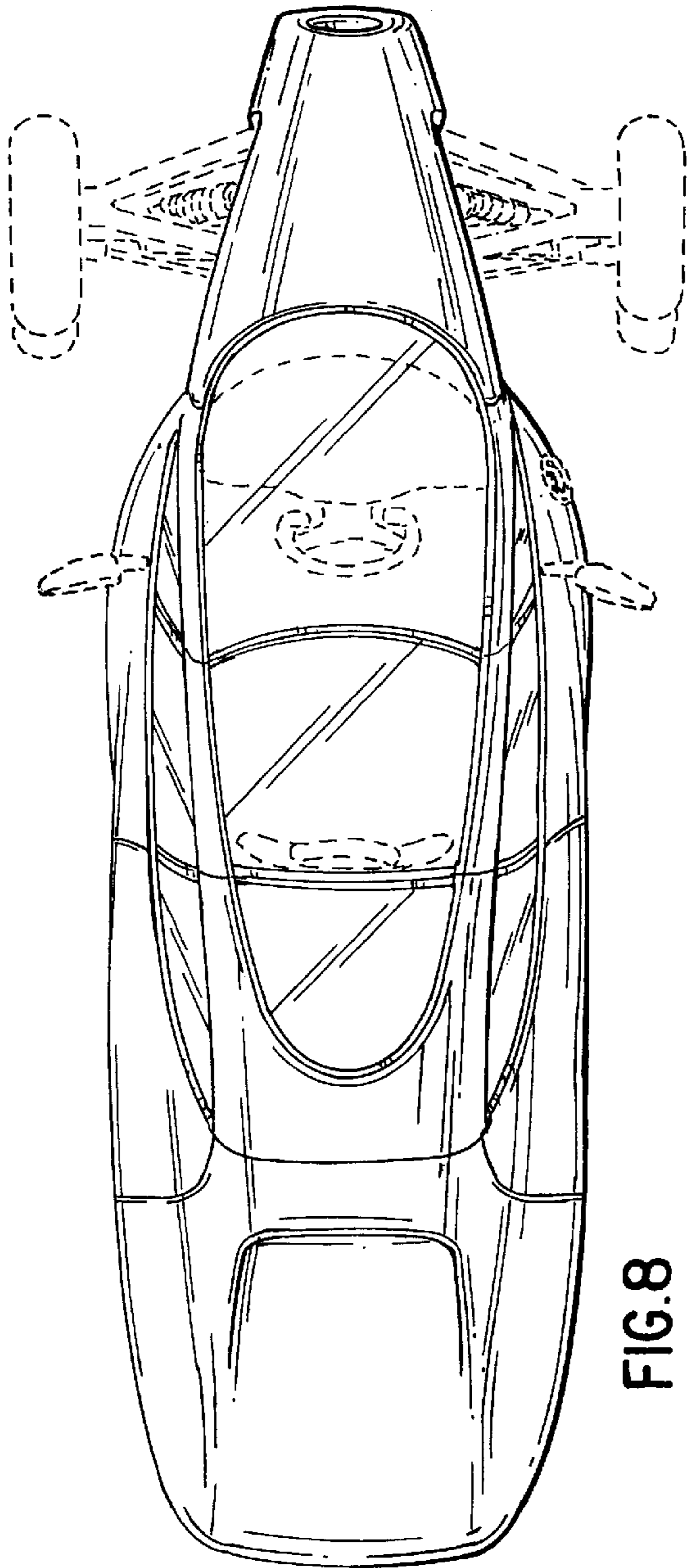

FIG. 8

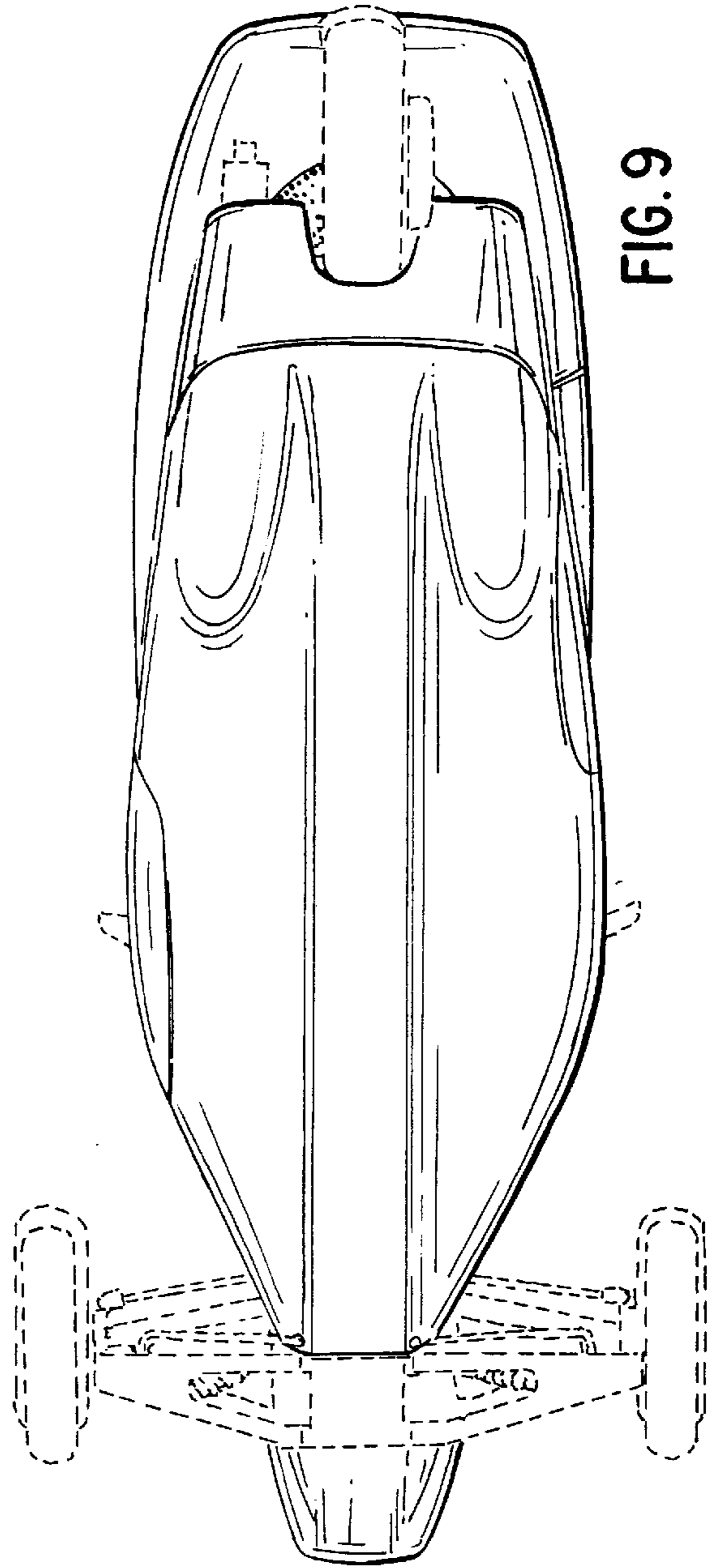

FIG. 9

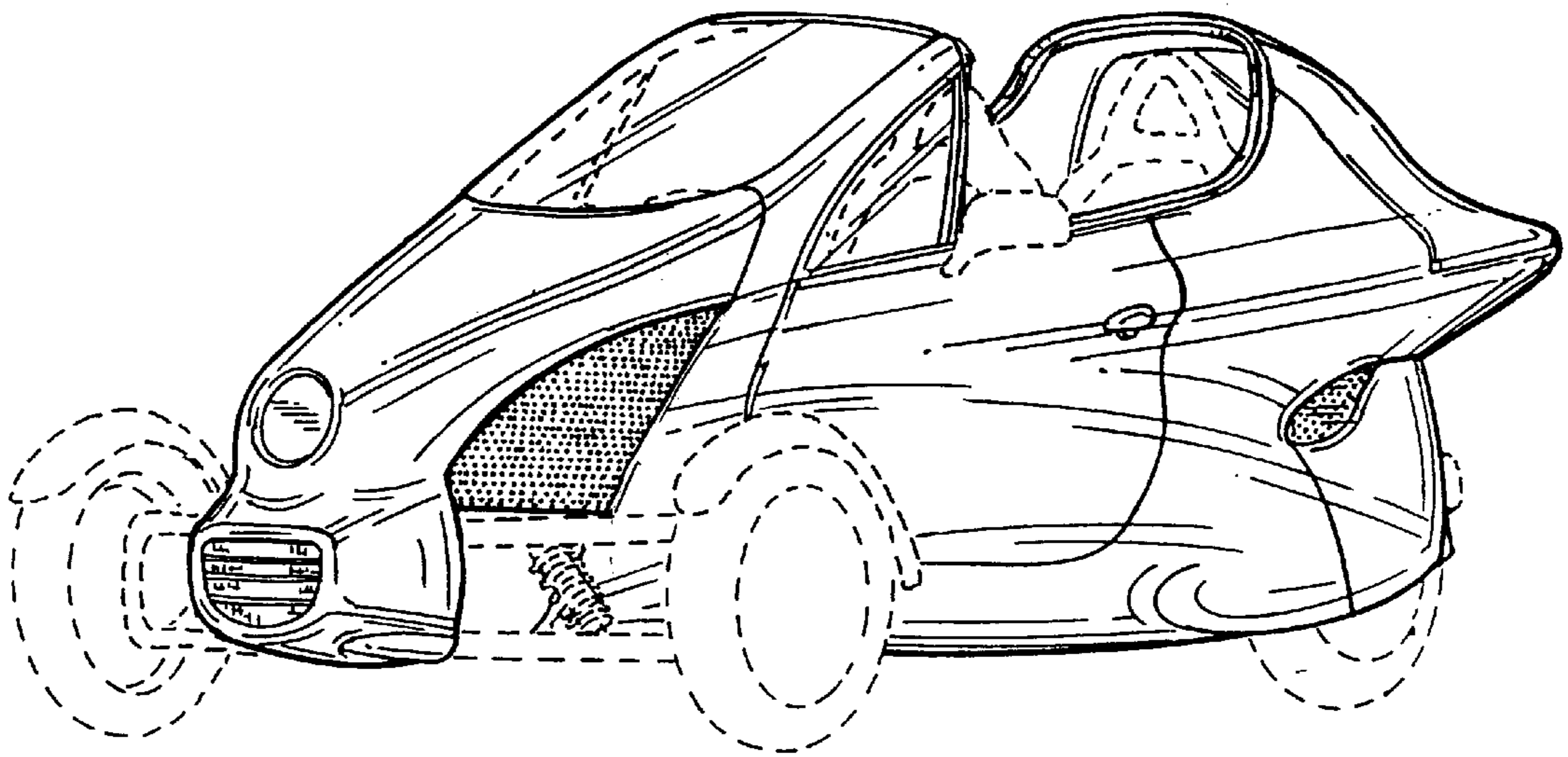

FIG. 10

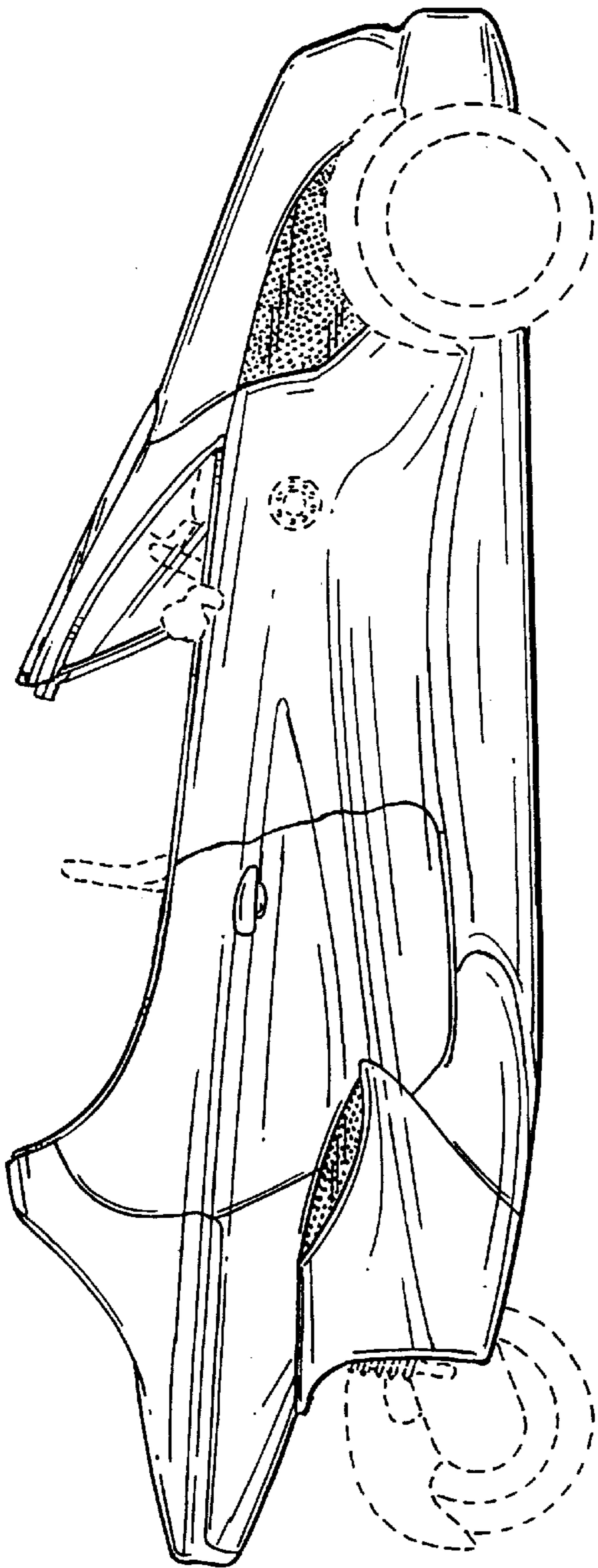

FIG. 11

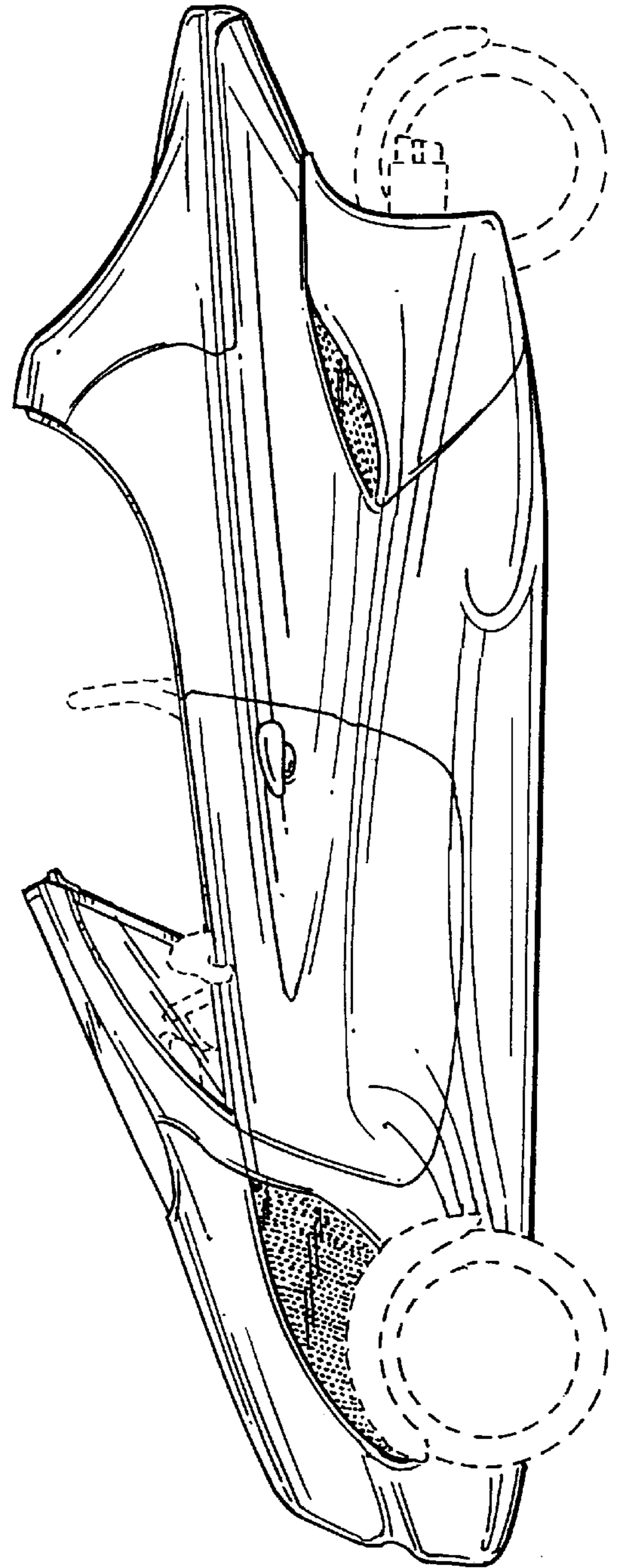

FIG. 12

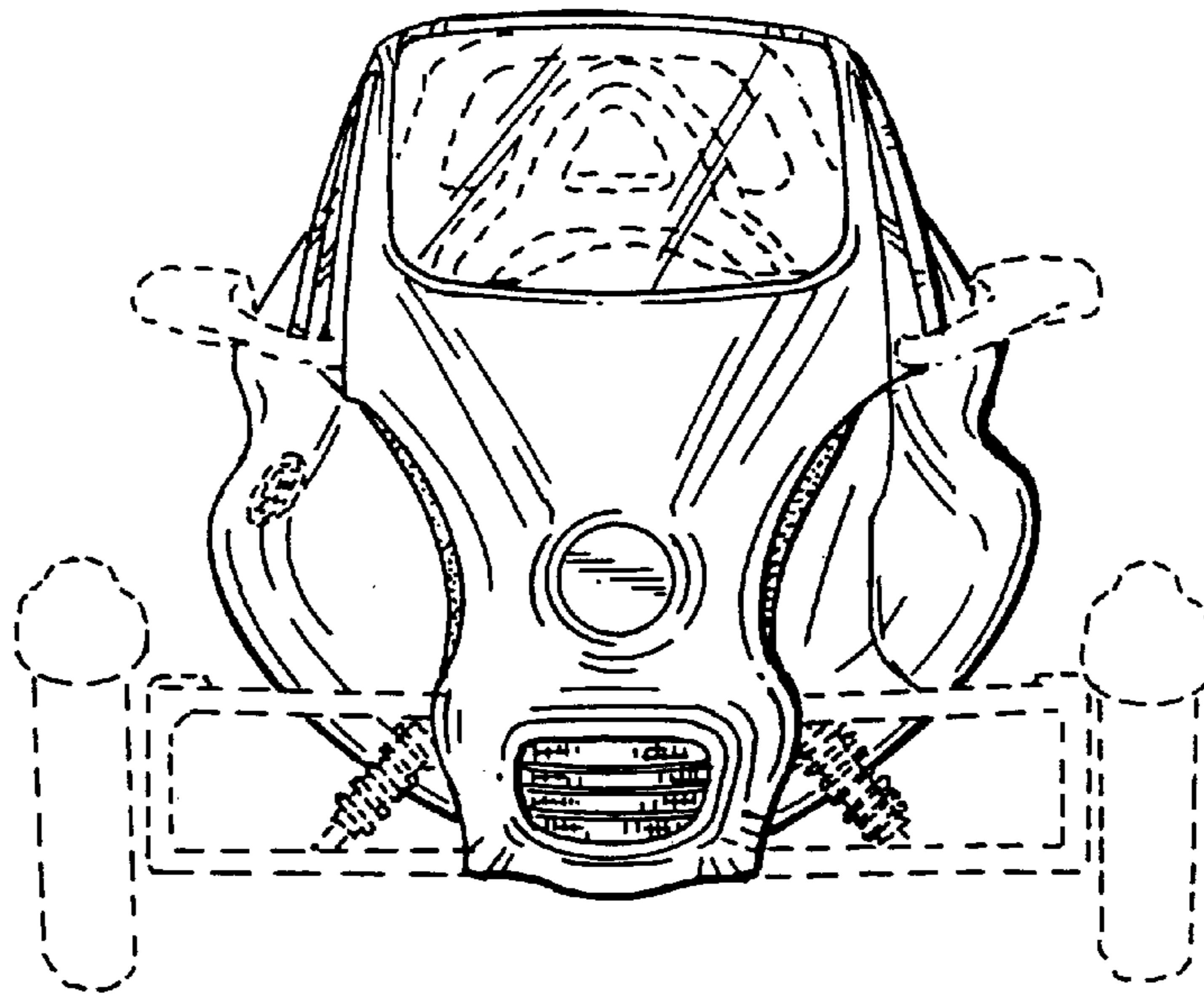

FIG. 13

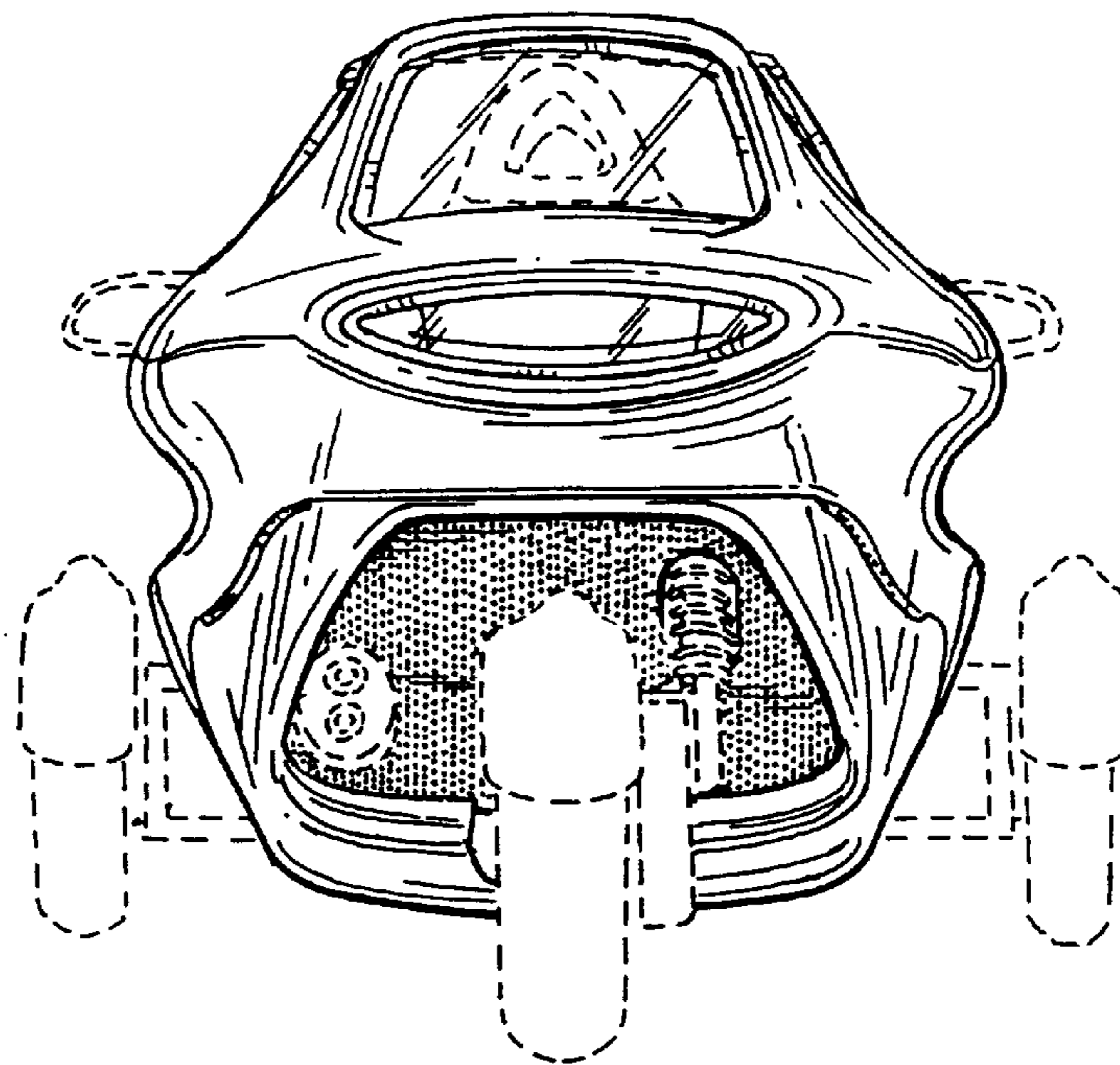

FIG. 14

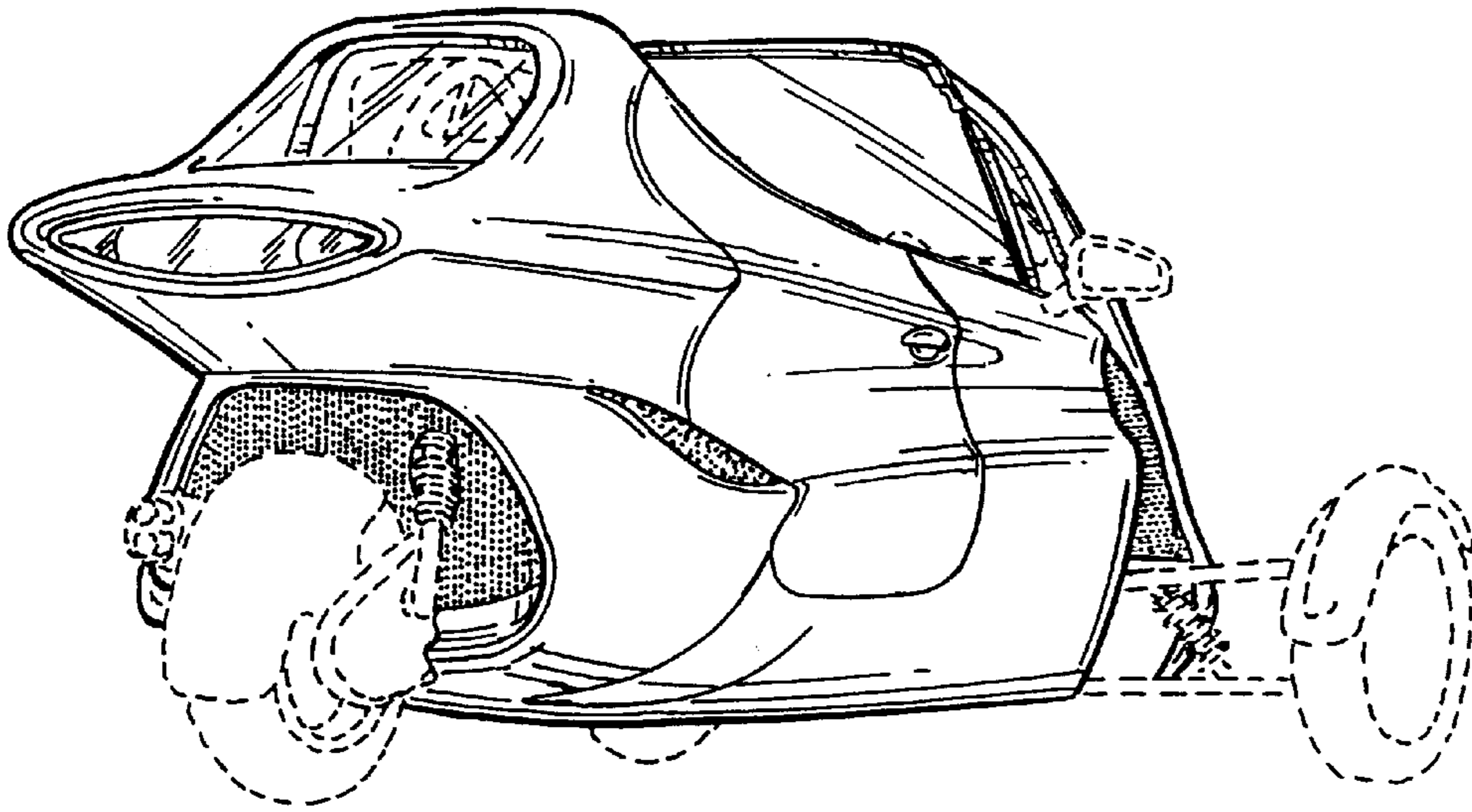

FIG. 15

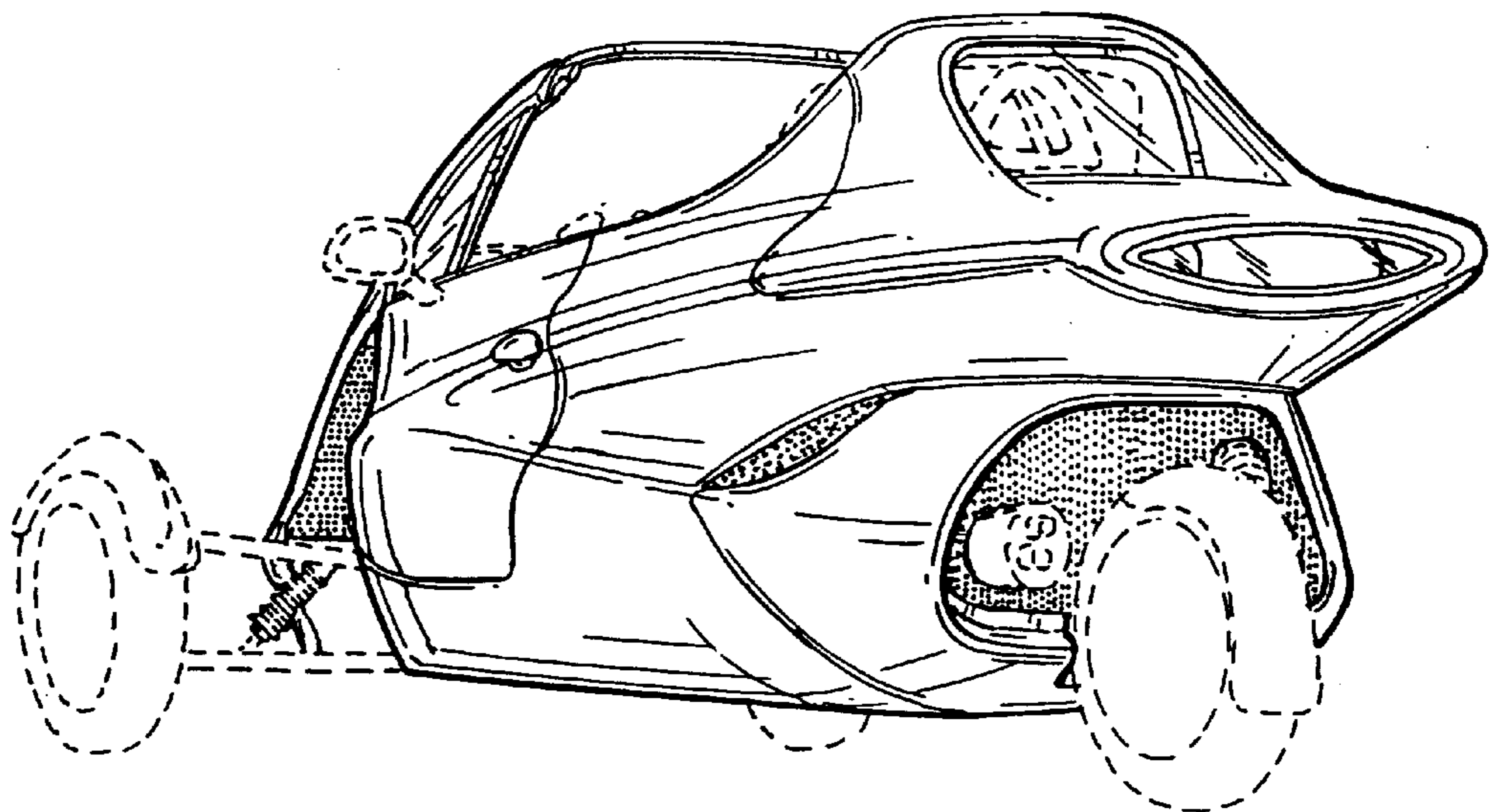

FIG. 16

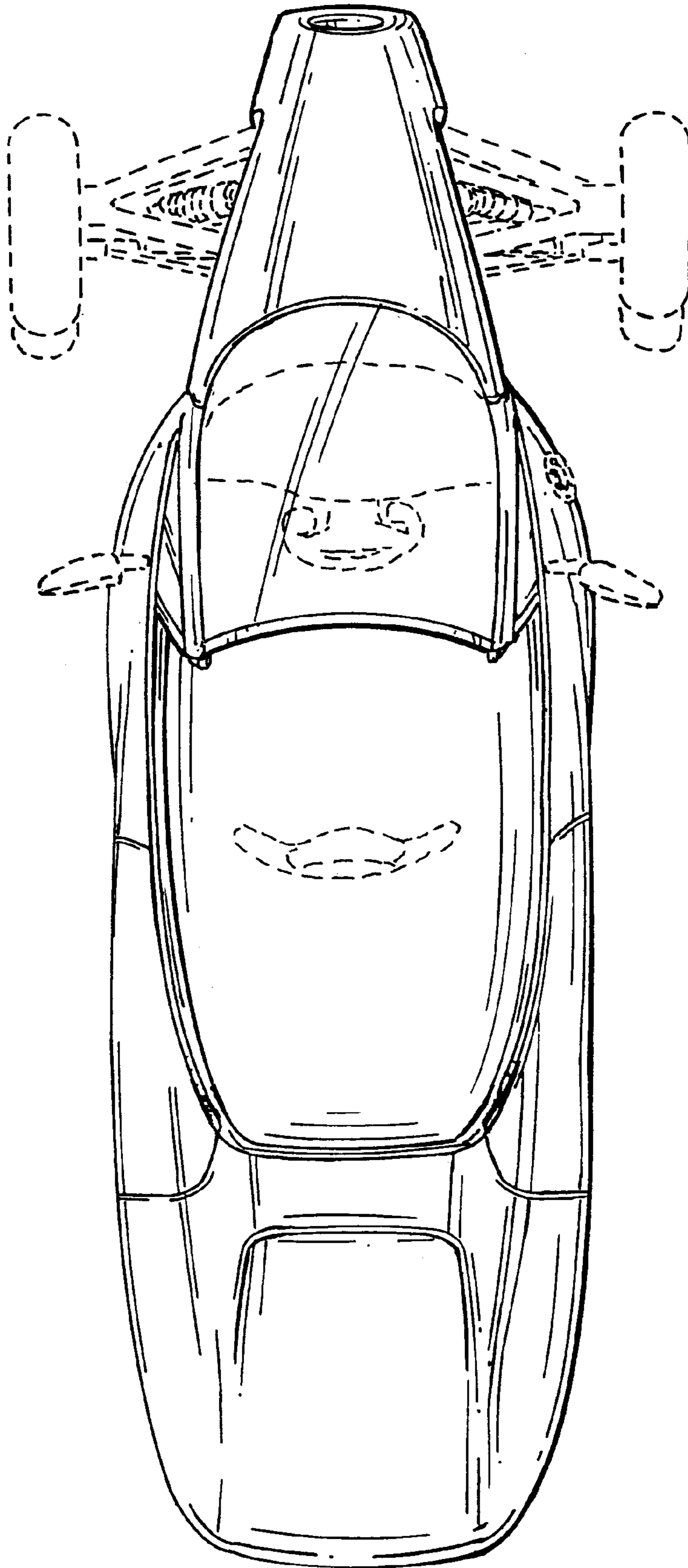

FIG. 17