



US00D427501S

United States Patent [19]

Berg et al.

[11] Patent Number: Des. 427,501

[45] Date of Patent: ** Jul. 4, 2000

[54] **BLADE LATCH LEVER FOR A MULTIPURPOSE FOLDING TOOL**

[75] Inventors: **Howard G. Berg**, Gresham; **Benjamin C. Rivera**, West Linn; **Timothy S. Leatherman**, Portland, all of Oreg.

[73] Assignee: **Leatherman Tool Group, Inc.**, Portland, Oreg.

[**] Term: **14 Years**

[21] Appl. No.: **29/099,876**

[22] Filed: **Jan. 29, 1999**

[51] **LOC (7) Cl.** **08-05**

[52] **U.S. Cl.** **D8/105**

[58] **Field of Search** D8/105, 26, 99, D8/55, 81, 87, 331; 30/161, 164, 153, 152; 7/118, 125-135, 138, 143, 164, 170; 81/177.1, 177.2, 177.6, 427.5; 24/563, 646; D11/216, 218, 87; 606/167

[56] **References Cited**

U.S. PATENT DOCUMENTS

D. 171,045	12/1953	Noe	D11/216
D. 302,140	7/1989	Johnston	D11/216
D. 312,987	12/1990	Kuli	D11/218
D. 371,498	7/1996	Lai	D8/105
D. 377,446	1/1997	Ford et al.	D8/331
1,659,705	2/1928	Roehr	D11/87 X
2,473,758	6/1949	Maitlen	7/168 X
3,147,530	9/1964	Goldman	D11/216 X
3,166,146	1/1965	Shaw	D11/216 X
3,176,691	4/1965	Ericson	24/563 X
4,075,458	2/1978	Moyer	219/225
4,330,937	5/1982	Cope	30/153
4,442,600	4/1984	Felix-Dalichow	30/161

4,502,221	3/1985	Pittman	30/160
4,854,045	8/1989	Schaub	30/155
4,918,775	4/1990	Leu	7/168
5,676,677	10/1997	Landis et al.	606/167
5,697,114	12/1997	McIntosh et al.	7/129
5,978,993	11/1999	Rivera	7/128
5,979,059	11/1999	Leatherman et al.	30/161

OTHER PUBLICATIONS

Gorilla & Sons, Inc., p. 80, Items A & B Multi-lock tools. SOG Specialty Knives, Inc., PowerLock® Multipurpose Tool At least as early as Nov. 27, 1998.

Primary Examiner—Jeffrey Asch
Attorney, Agent, or Firm—Chernoff, Vilhauer, McClung & Stenzel, LLP

[57] **CLAIM**

The ornamental design for a blade latch lever for a multipurpose folding tool, as shown and described.

DESCRIPTION

FIG. 1 is an isometric view from the left front of a blade latch lever for a multipurpose folding tool showing our new design;

FIG. 2 is a top plan view thereof;

FIG. 3 is a left side elevational view thereof;

FIG. 4 is a front and elevational view thereof; and,

FIG. 5 is a rear end elevational view thereof. The depiction of a portion of a handle of a multipurpose folding tool in broken line in FIGS. 1-5 is environmental only and forms no part of the claimed design.

The portions of the article obscured by the broken line disclosure are not considered to be a part of the claimed design.

The right side is a mirror image of that shown in FIG. 3.

1 Claim, 1 Drawing Sheet

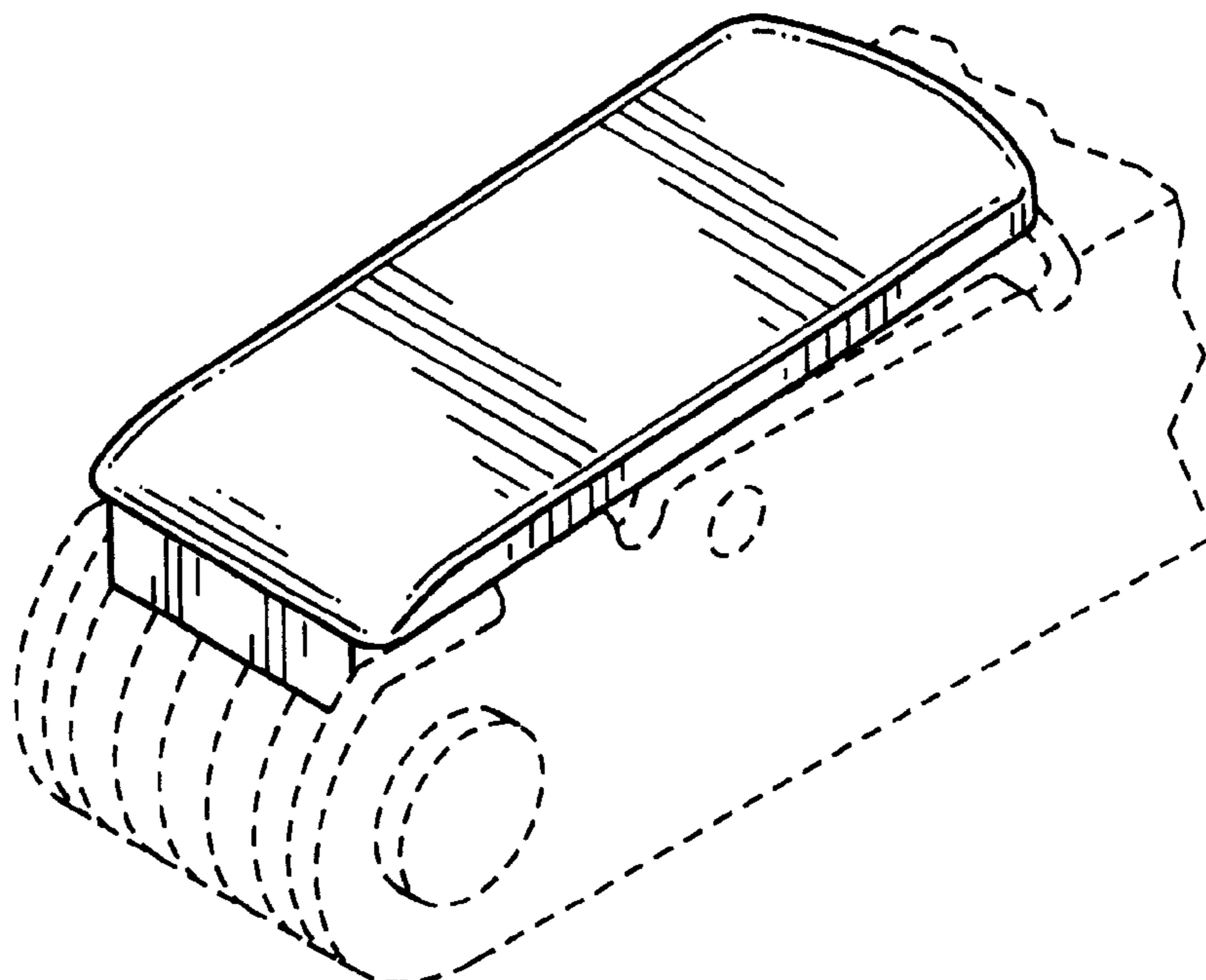

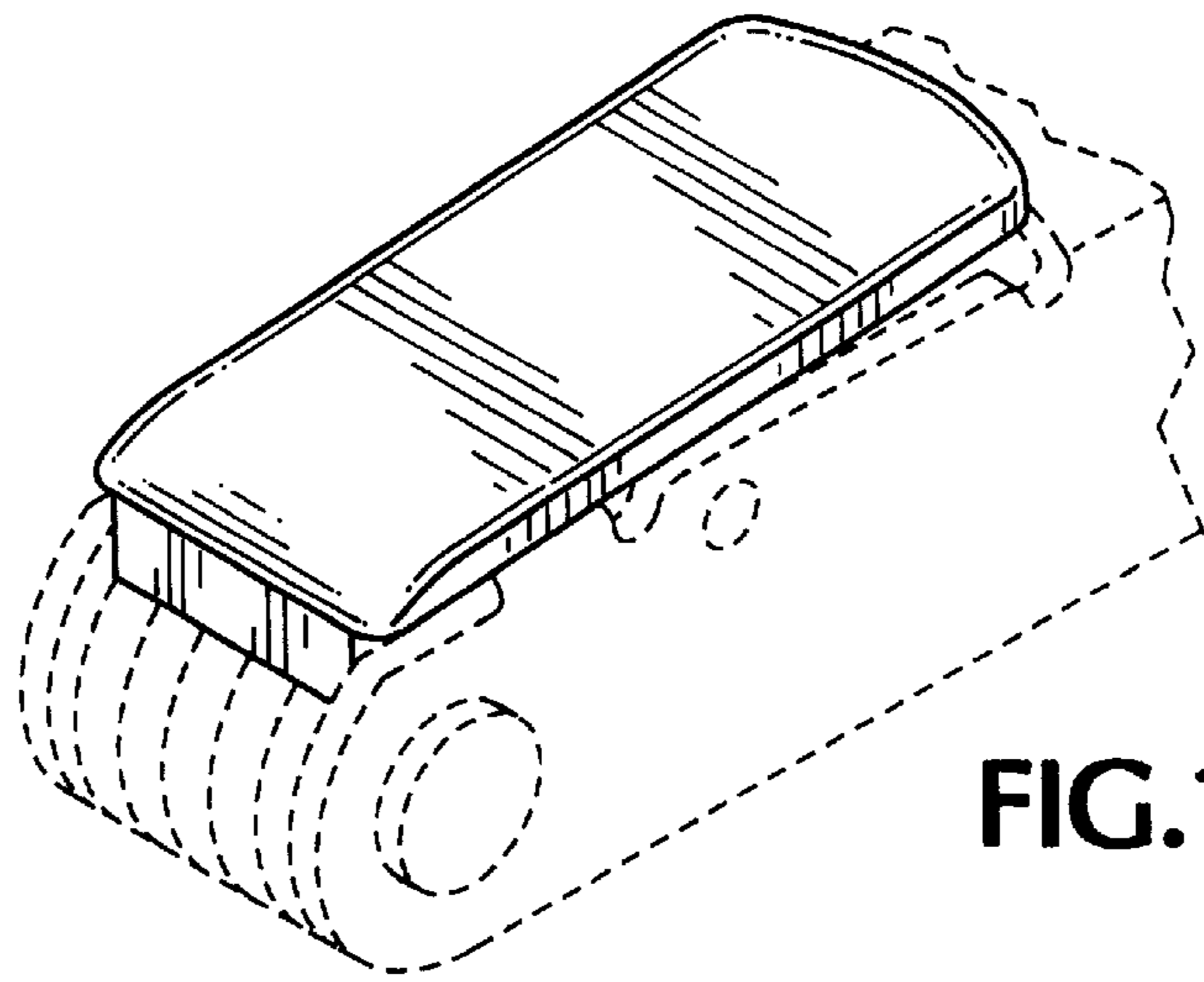

FIG. 1

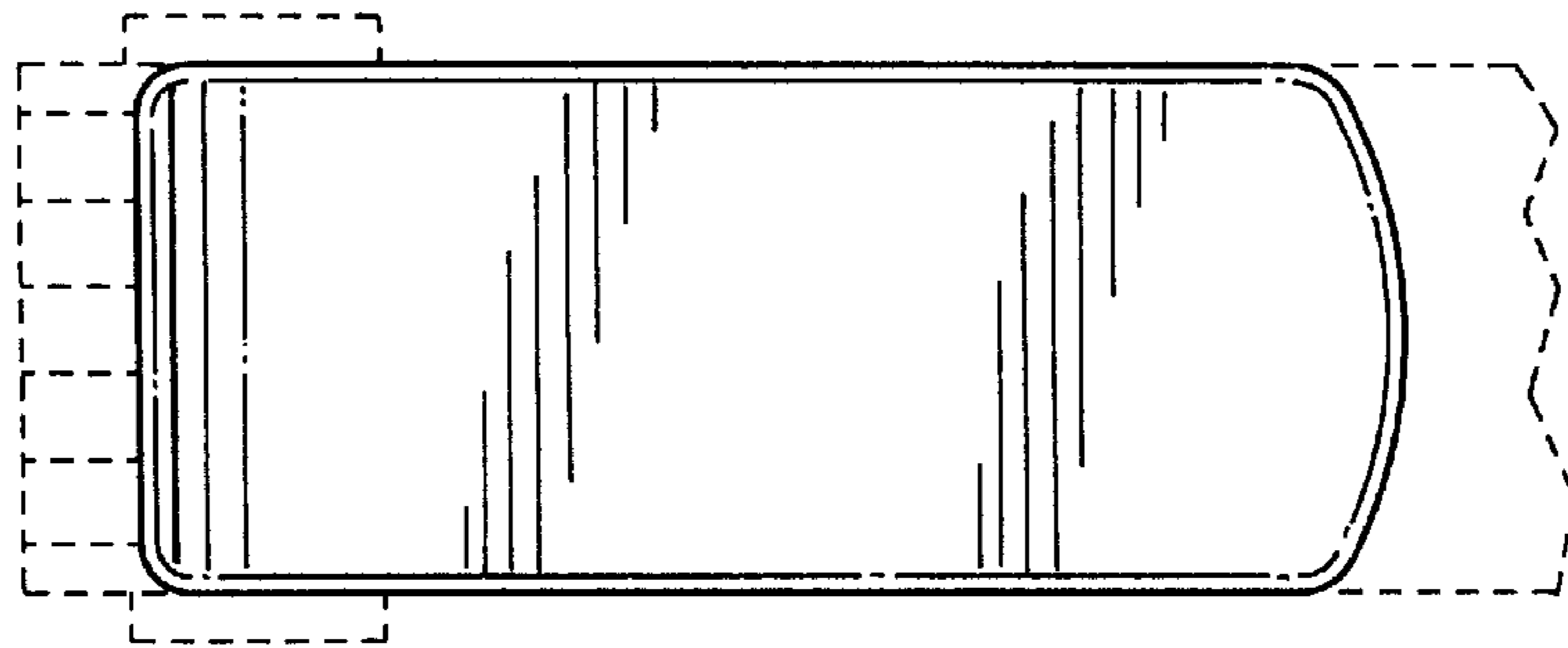

FIG. 2

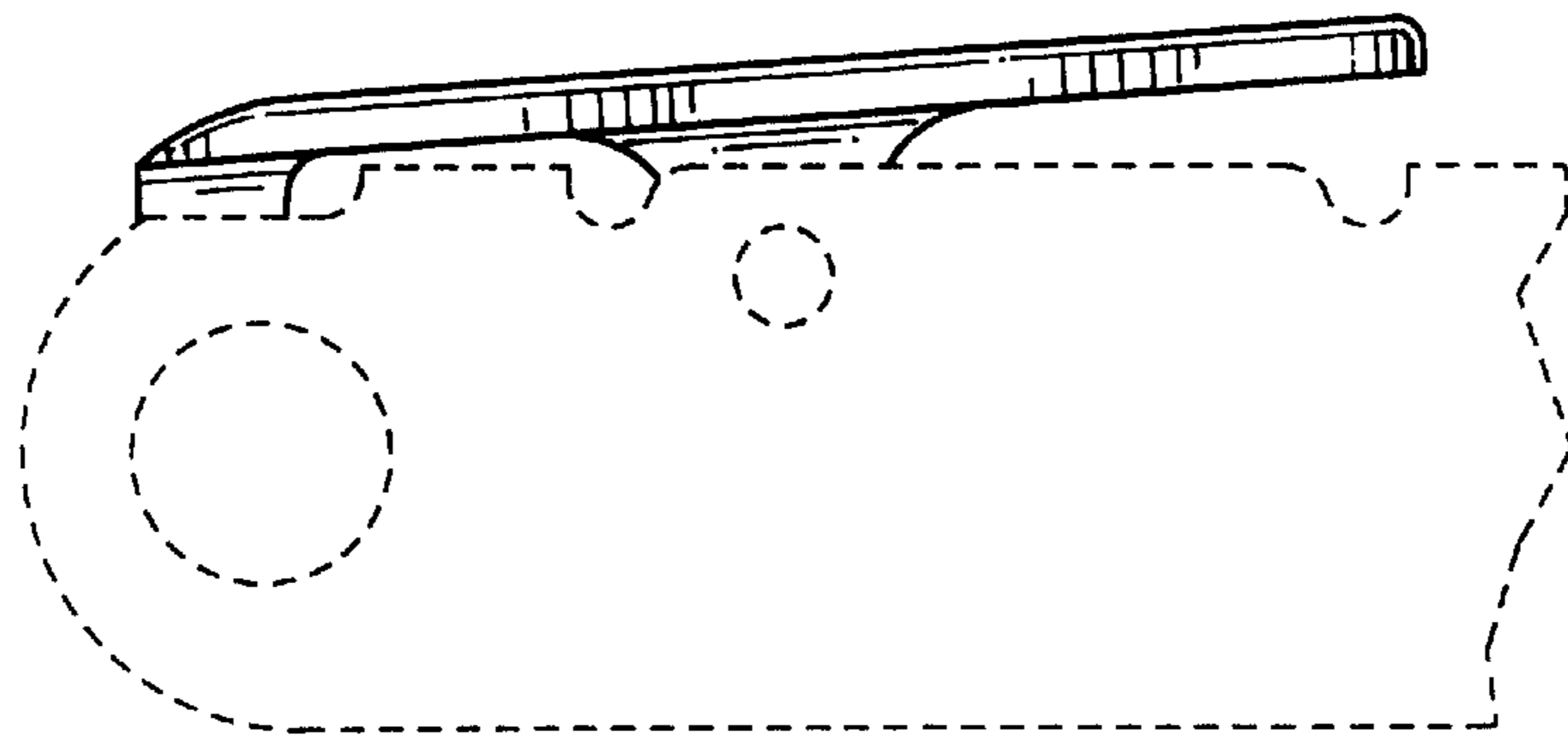

FIG. 3

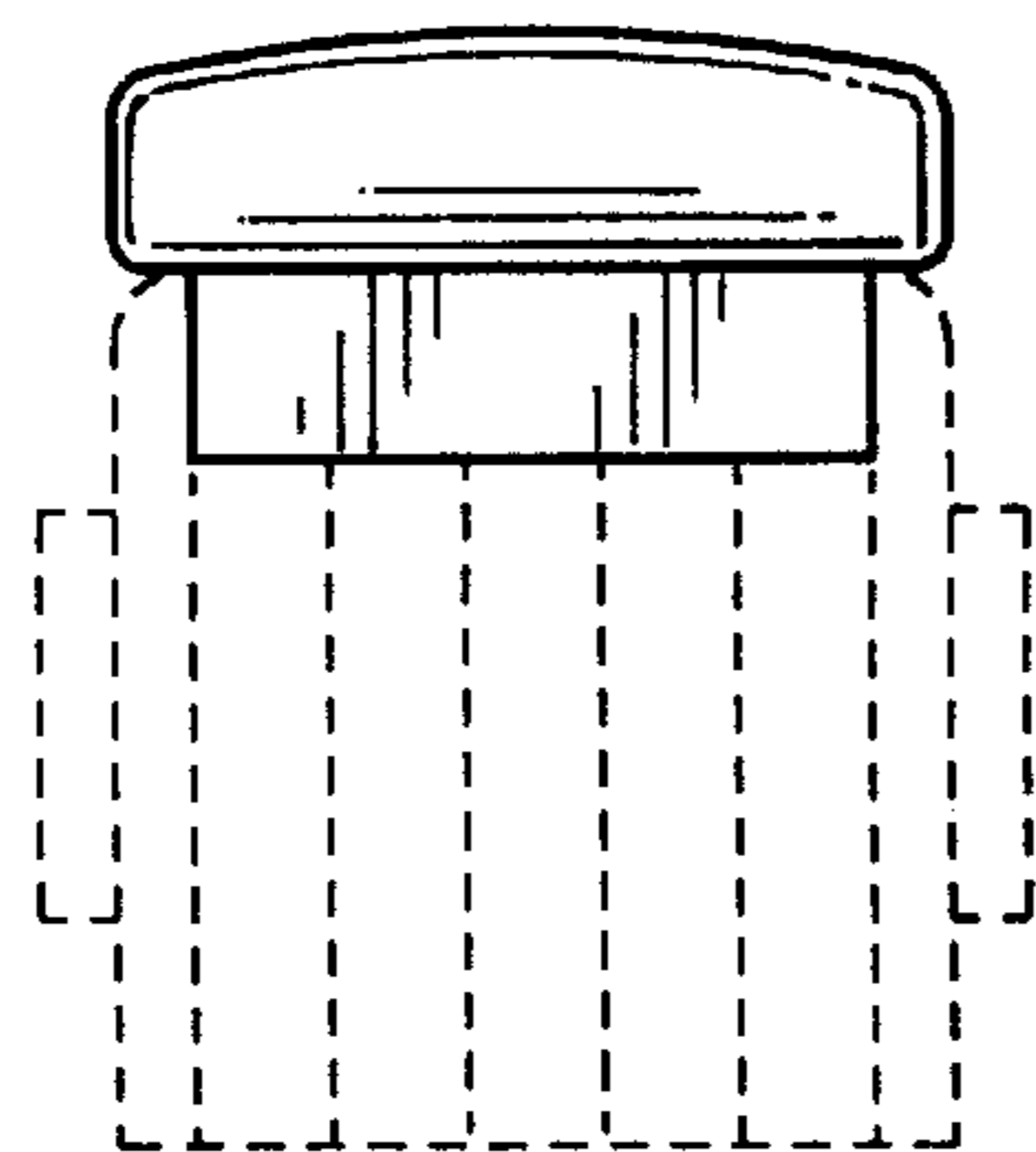

FIG. 4

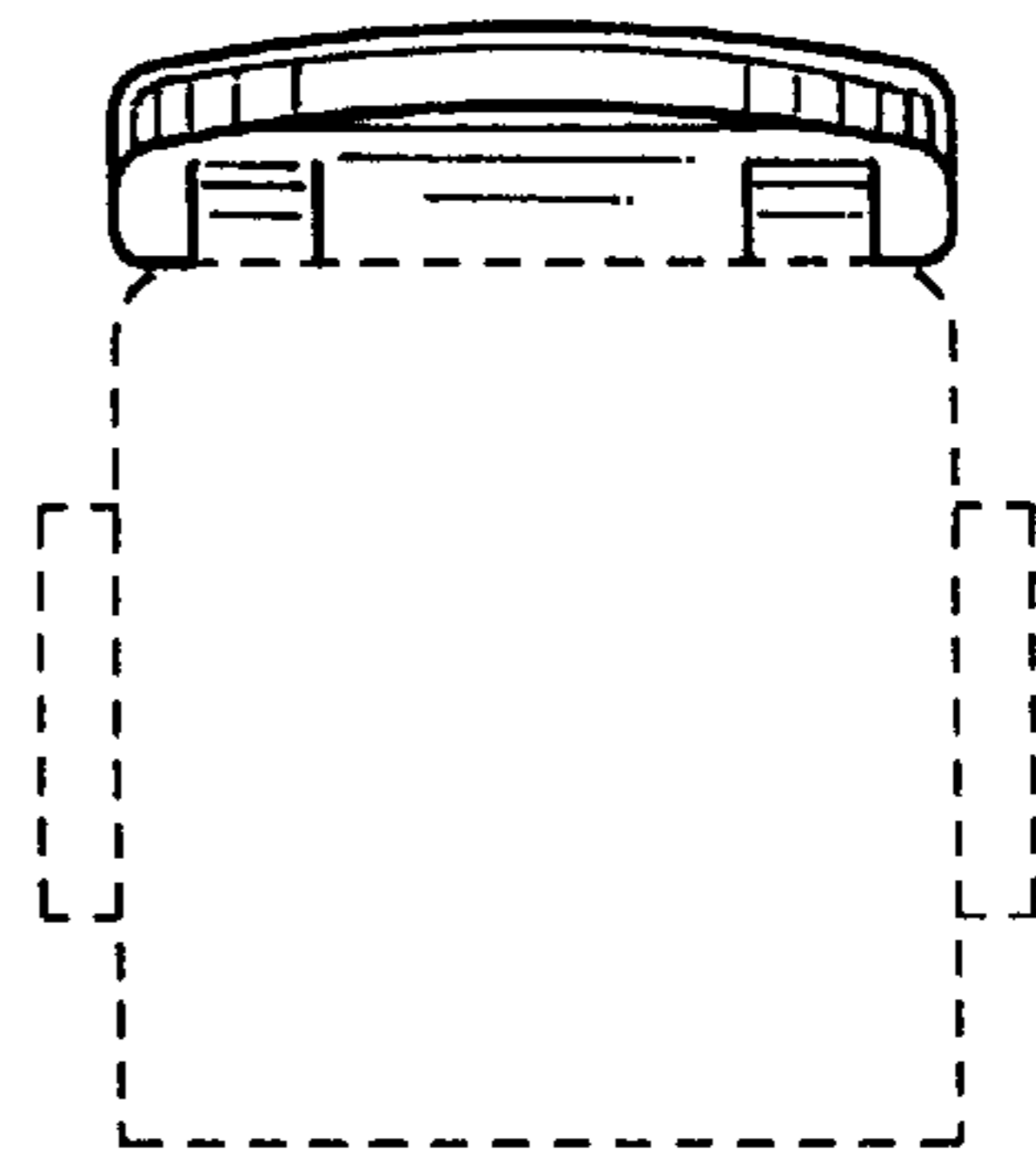

FIG. 5