



US00D427160S

United States Patent [19] Feierbach

[11] Patent Number: Des. 427,160

[45] Date of Patent: ** Jun. 27, 2000

[54] **DESKTOP COMPUTER WORKSTATION**

[76] Inventor: **Wolfgang R. Feierbach**,
Industriestrasse 6, D-63674
Altenstadt/Hessen, Germany

[**] Term: **14 Years**

[21] Appl. No.: **29/098,057**

[22] Filed: **Dec. 21, 1998**

[30] **Foreign Application Priority Data**

Jul. 17, 1998 [DE] Germany 4 98 07 183

[51] **LOC (7) Cl.** **14-02**

[52] **U.S. Cl.** **D14/100**

[58] **Field of Search** D14/100, 101,
D14/106, 115, 126-129; 345/104, 156,
168, 169, 173; 361/680-686; 364/708.1;
400/486, 489

[56] **References Cited**

U.S. PATENT DOCUMENTS

D. 272,445	1/1984	Ohie	D14/106
D. 349,694	8/1994	Takimoto	D14/106
D. 352,500	11/1994	Hackleman	D14/100
D. 361,550	8/1995	Mundt et al.	D14/100
D. 366,649	1/1996	Soderburg	D14/106
D. 372,900	8/1996	Nakada et al.	D14/100
5,548,478	8/1996	Kumar	.	

OTHER PUBLICATIONS

“CE Pro Portables: Bigger Than a PDA, Smaller Than a Notebook”, PC World, Jan. 1999, pp. 54, 58.

Primary Examiner—Freda Nunn

Attorney, Agent, or Firm—Knobbe Martens Olson & Bear LLP

[57] **CLAIM**

The ornamental design for a desktop computer workstation, as shown and described.

DESCRIPTION

FIG. 1 is a front elevational view of a desktop computer

workstation in accordance with a first preferred embodiment of the present invention, showing a monitor screen in an open position;

FIG. 2 is a right side elevational view of the computer workstation of FIG. 1, with the monitor screen in an open and rearward position, the left side elevational view being a mirror image thereof;

FIG. 3 is a right side elevational view of the computer workstation of FIG. 1, with the monitor screen in an open and intermediate position, the left side elevational view being a mirror image thereof;

FIG. 4 is a right side elevational view of the computer workstation of FIG. 1, with the monitor screen in an open and forward position, the left side elevational view being a mirror image thereof;

FIG. 5 is a right side elevational view of the computer workstation of FIG. 1, with the monitor screen in a closed position, the left side elevational view being a mirror image thereof;

FIG. 6 is a rear elevational view of the computer workstation of FIG. 1;

FIG. 7 is a top plan view of the computer workstation of FIG. 1;

FIG. 8 is a bottom plan view of the computer workstation of FIG. 1;

FIG. 9 is a front elevational view of a computer workstation in accordance with a second preferred embodiment of the present invention, showing a monitor screen in an open position;

FIG. 10 is a right side elevational view of the computer workstation of FIG. 9, with the monitor screen in an open and rearward position, the left side elevational view being a mirror image thereof;

FIG. 11 is a right side elevational view of the computer workstation of FIG. 9, with the monitor screen in an open and intermediate position, the left side elevational view being a mirror image thereof;

FIG. 12 is a right side elevational view of the computer workstation of FIG. 9, with the monitor screen in an open and forward position, the left side elevational view being a mirror image thereof;

FIG. 13 is a right side elevational view of the computer workstation of FIG. 9, with the monitor screen in a closed position, the left side elevational view being a mirror image thereof;

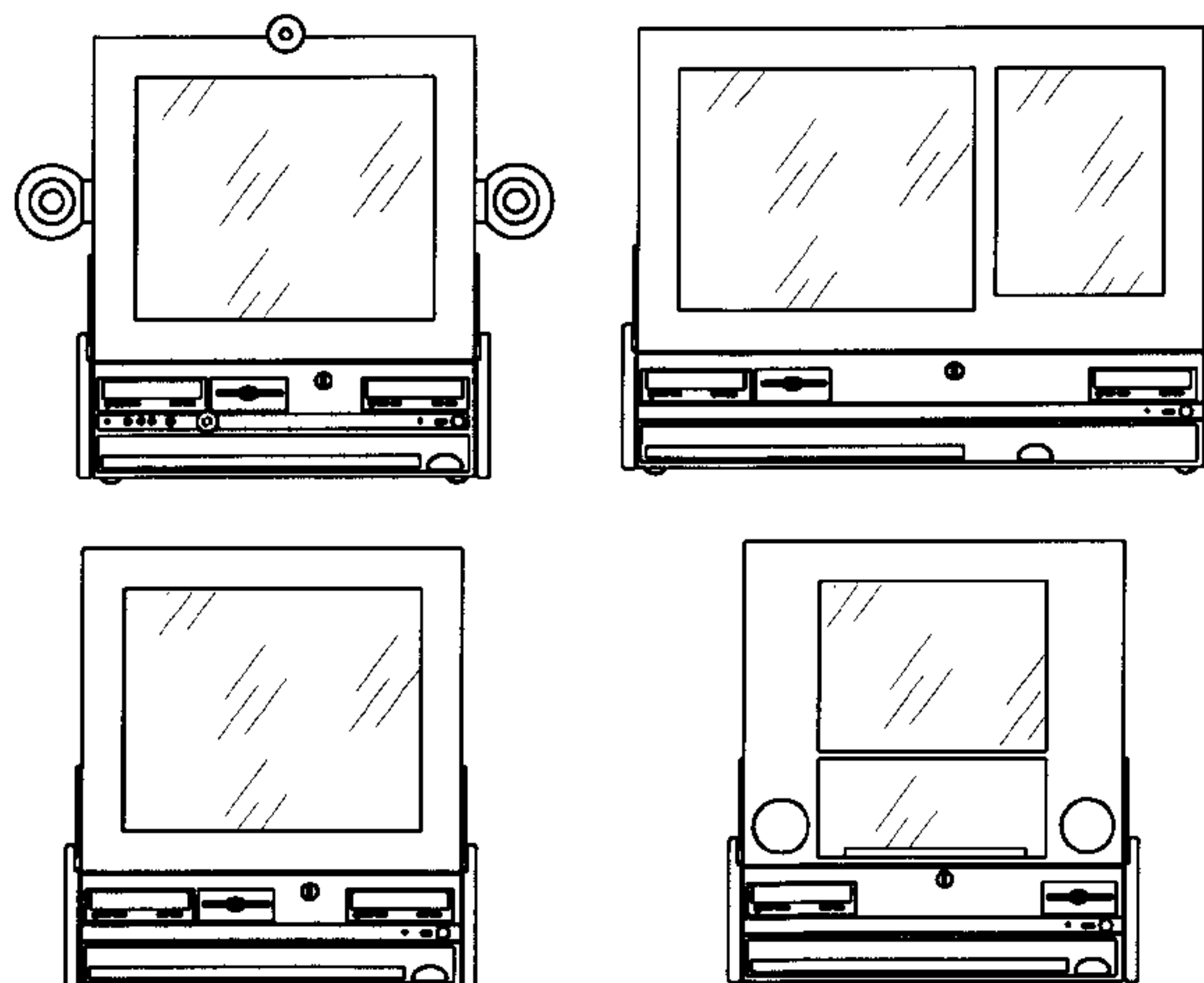

FIG. 53 is a right side elevational view of the computer workstation of FIG. 49, with the monitor screen in a closed position, the left side elevational view being a mirror image thereof;

FIG. 54 is a rear elevational view of the computer workstation of FIG. 49;

FIG. 55 is a top plan view of the computer workstation of FIG. 49;

FIG. 56 is a bottom plan view of the computer workstation of FIG. 49; and,

FIG. 57 is a left side elevational view of the computer workstation of FIG. 49.

1 Claim, 7 Drawing Sheets

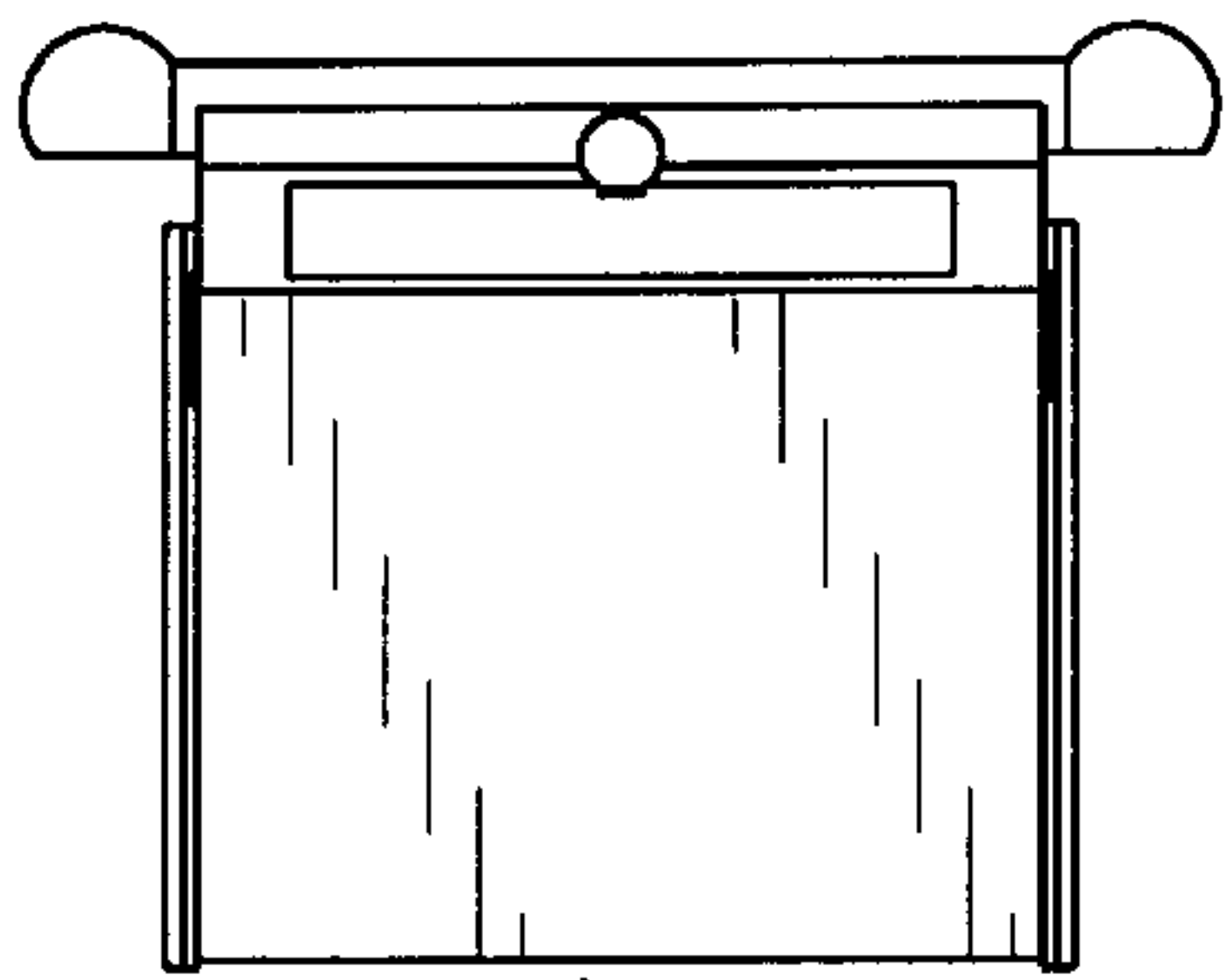

FIG. 7

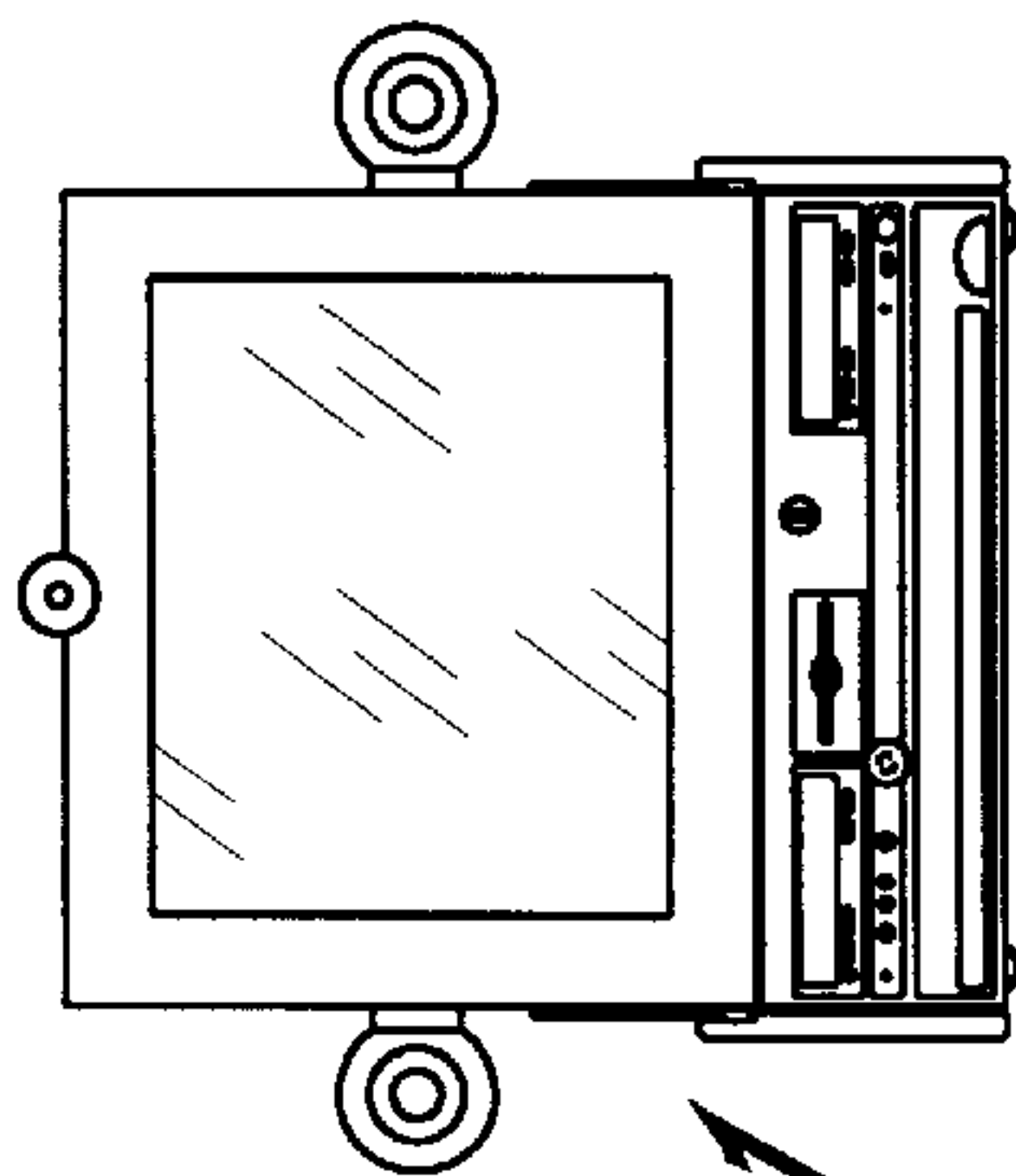

FIG. 1

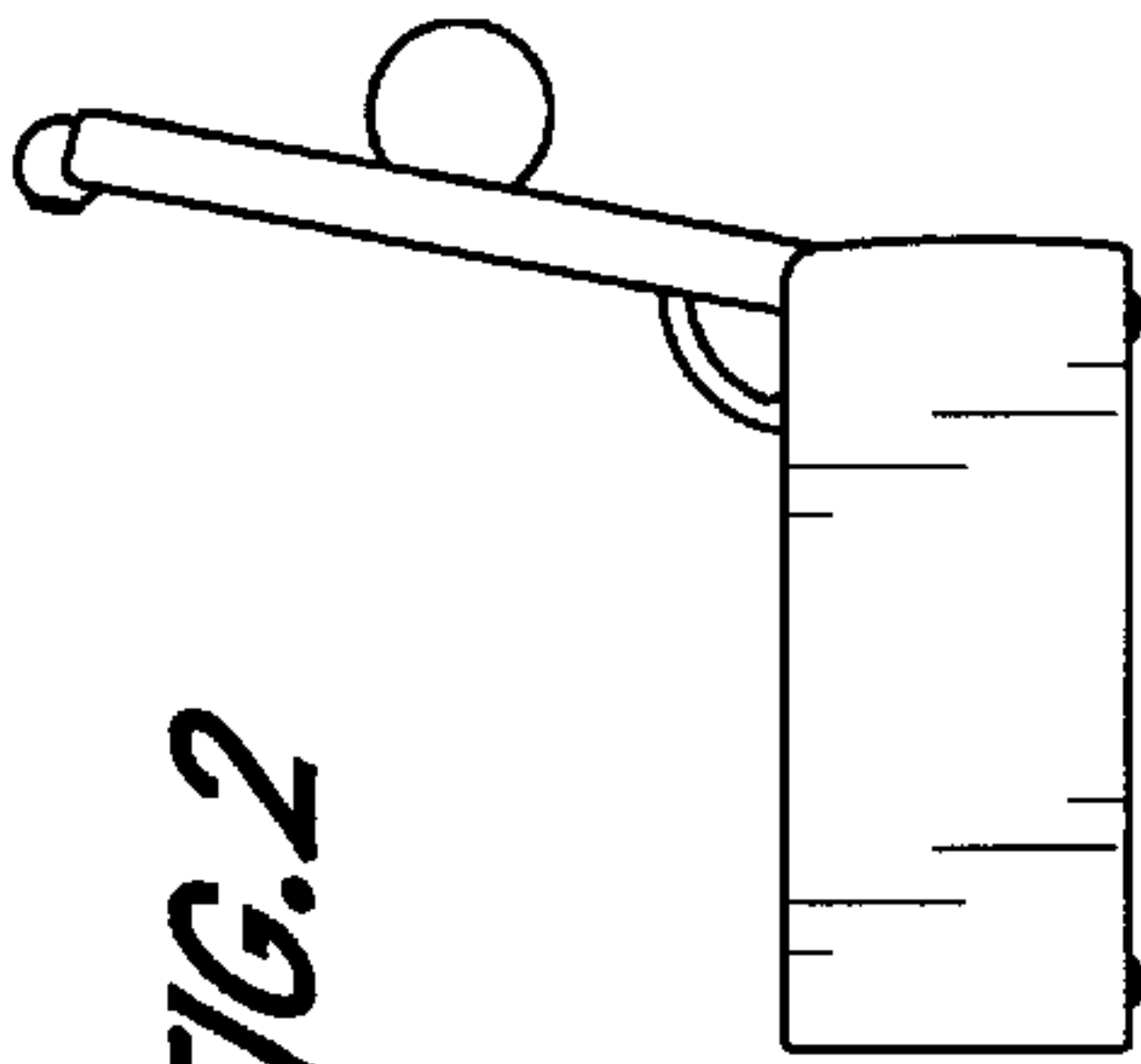

FIG. 2

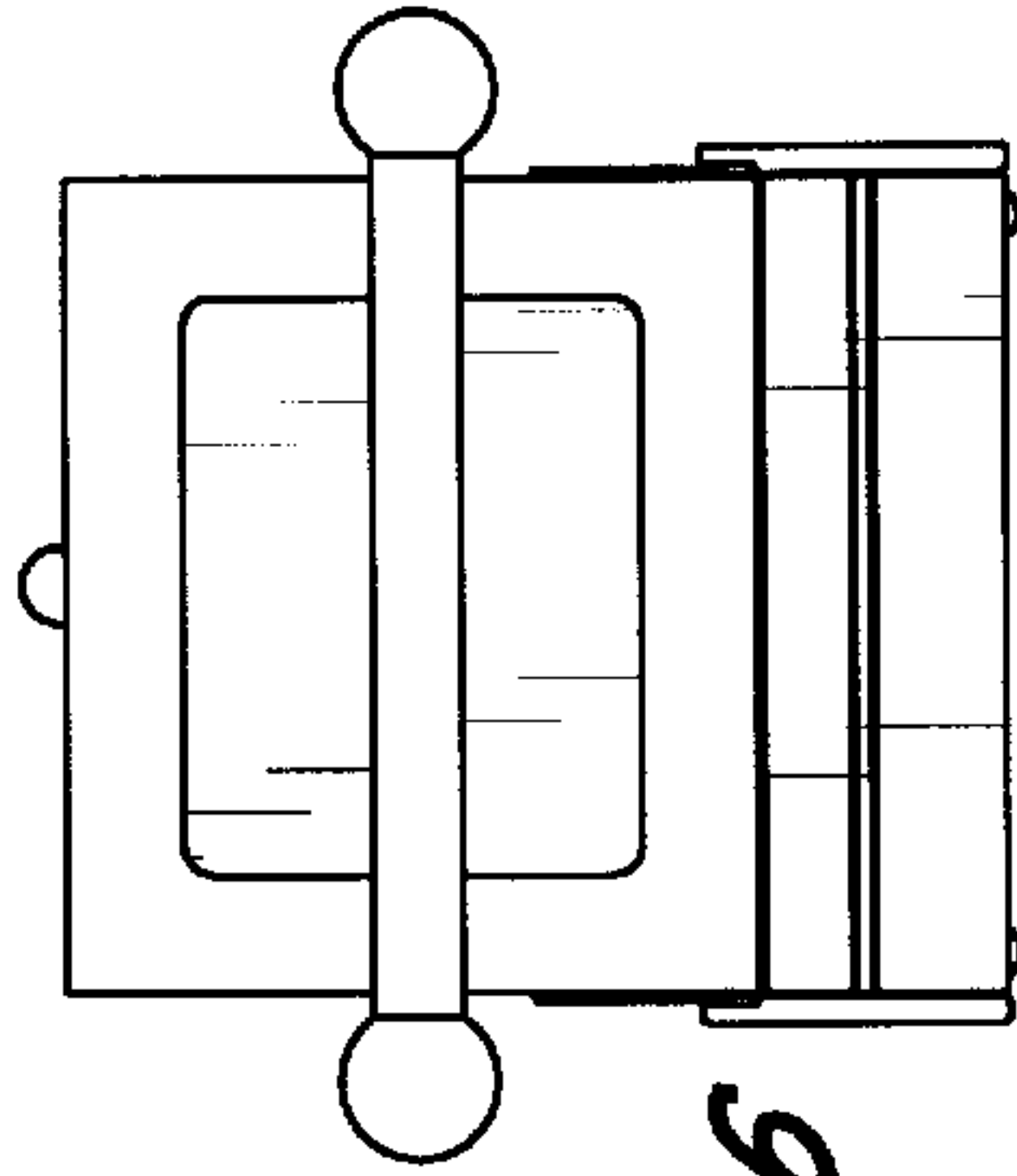

FIG. 6

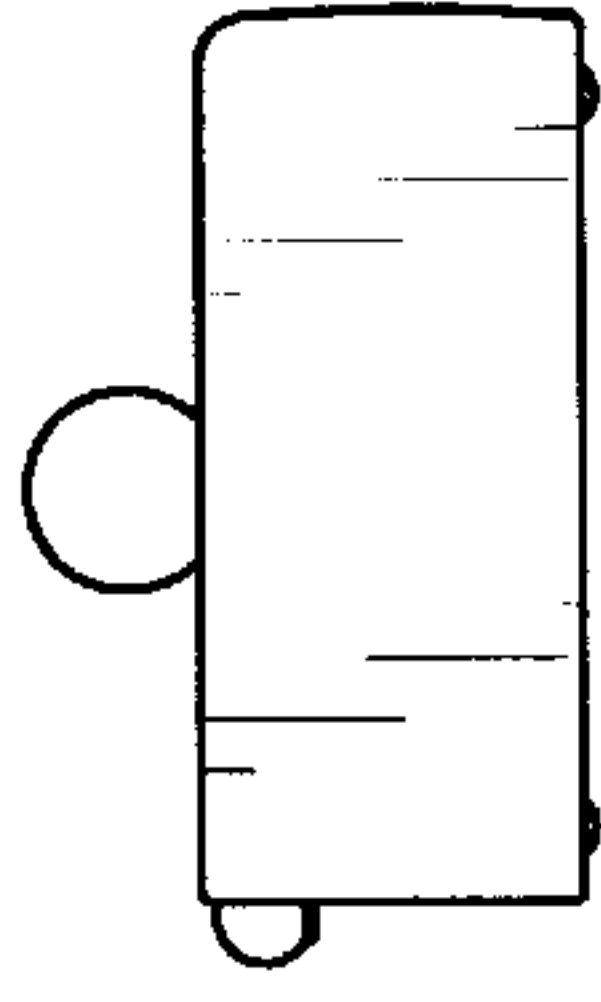

FIG. 5

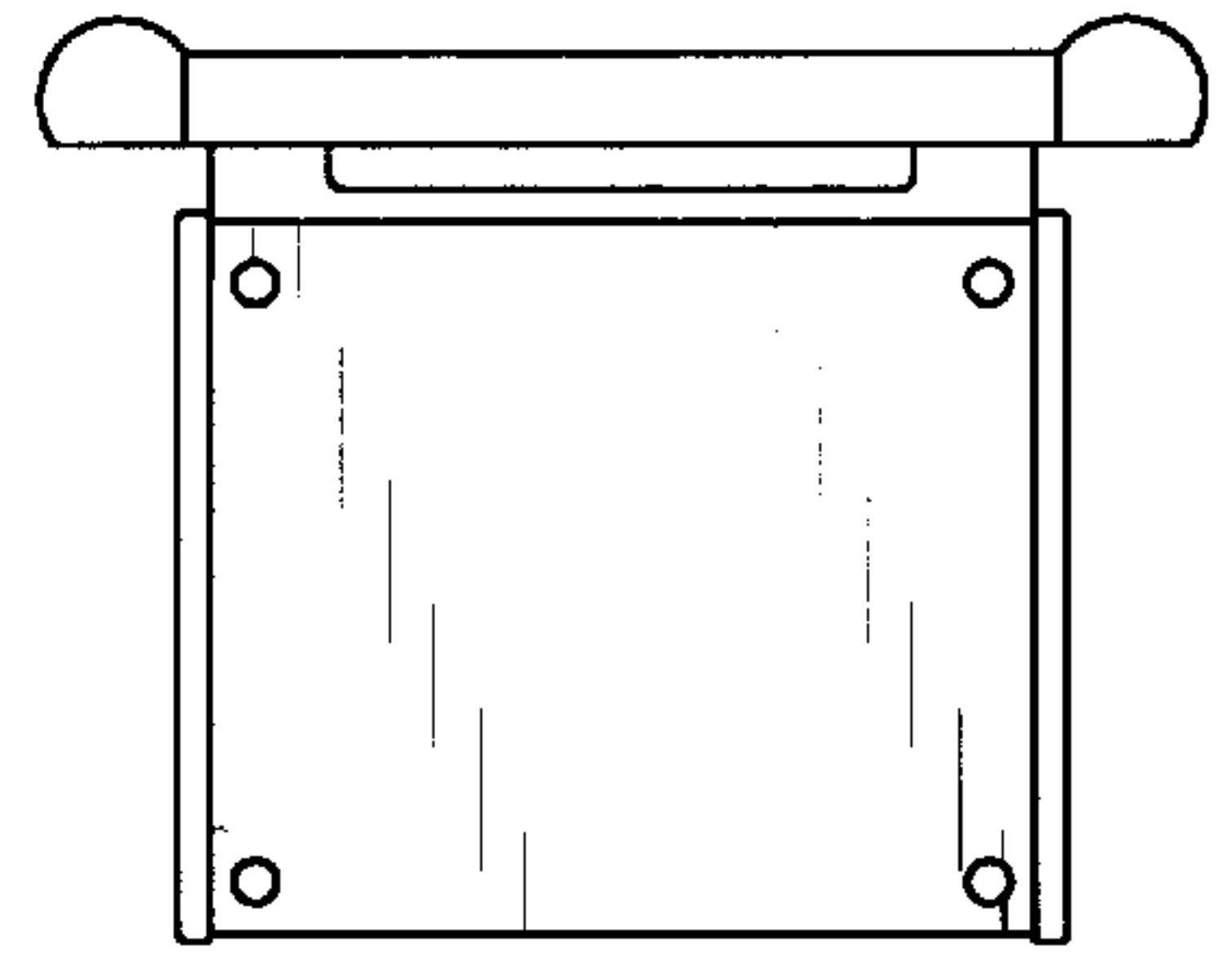

FIG. 8

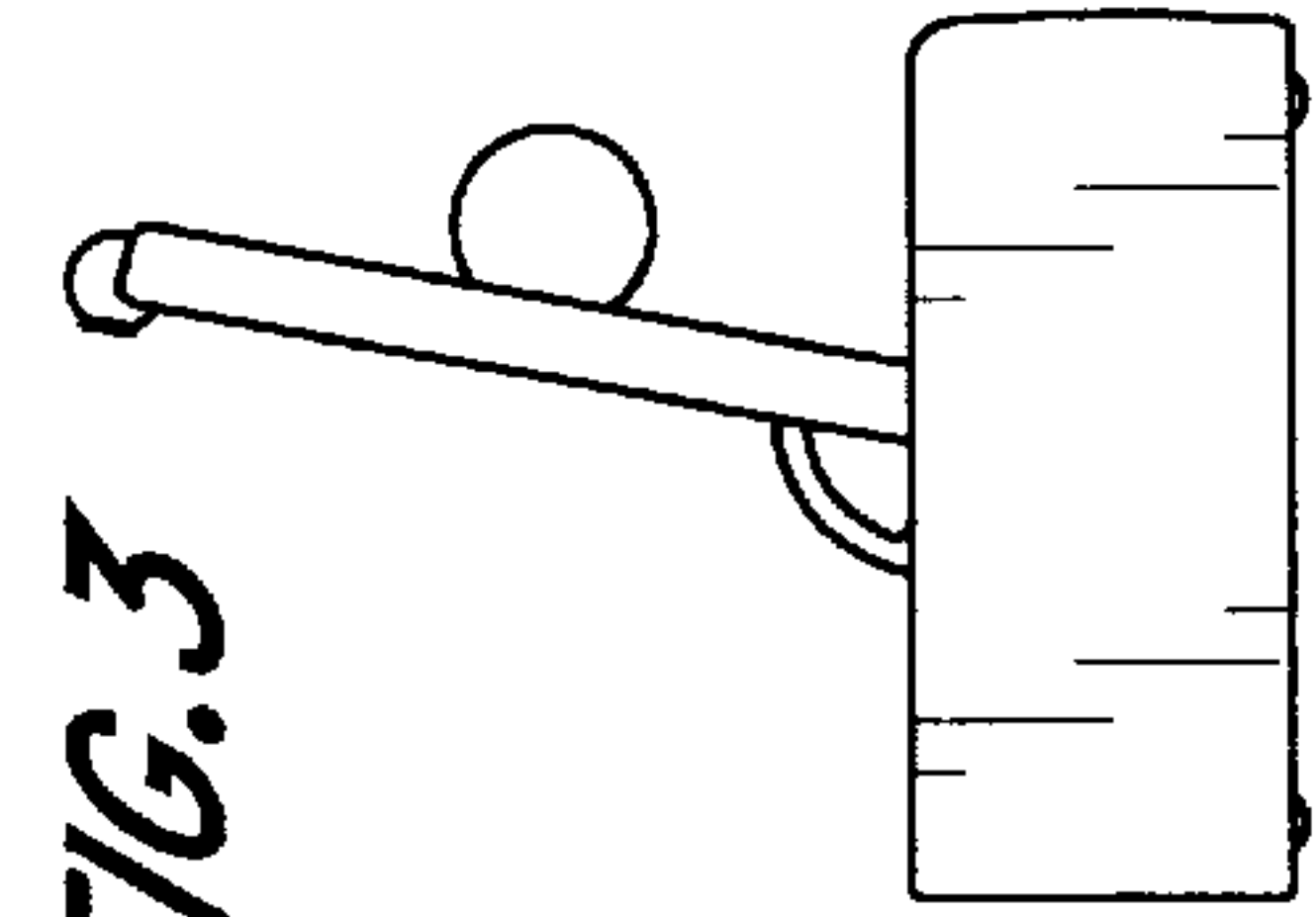

FIG. 3

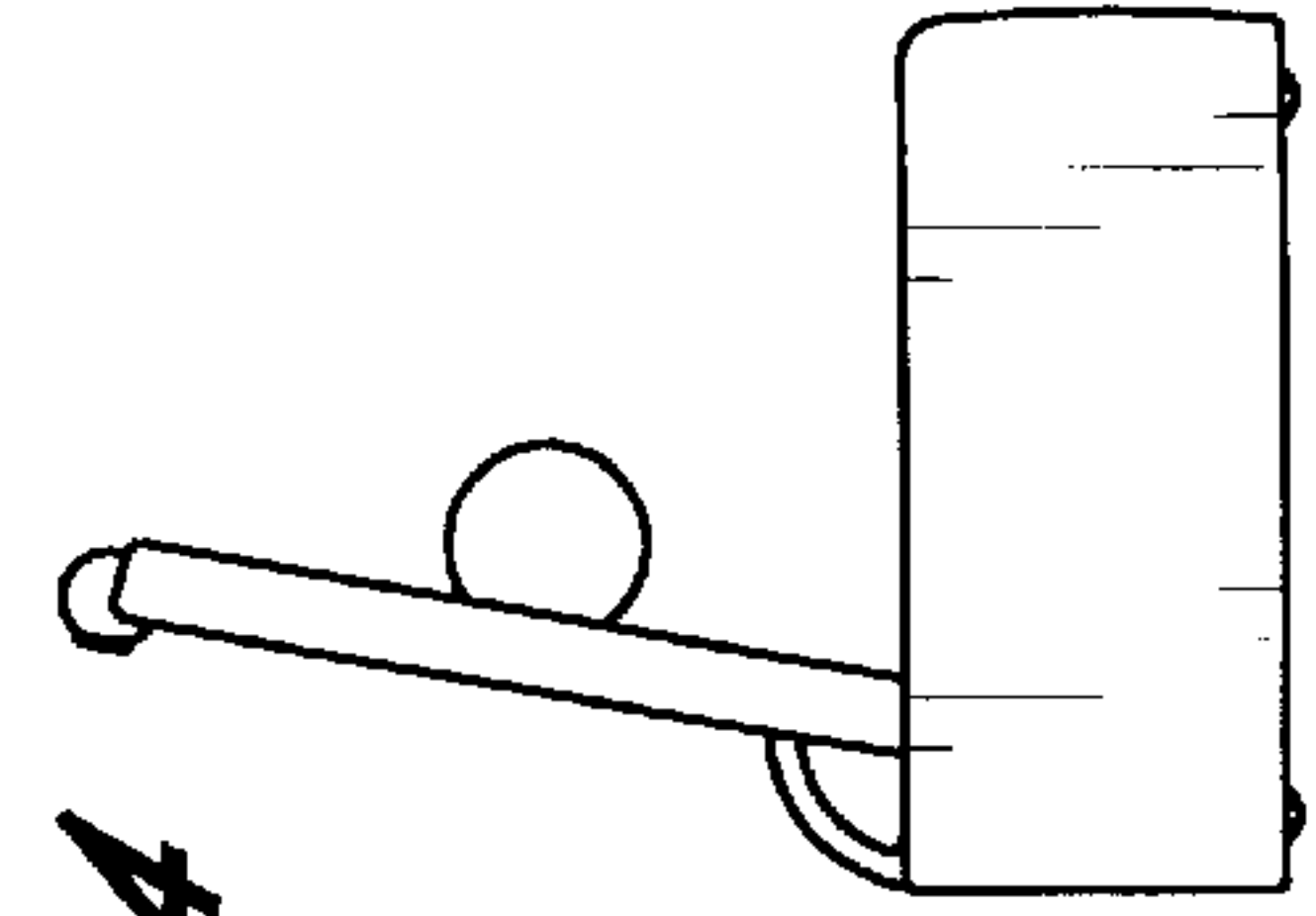

FIG. 4



FIG. 15

FIG. 13

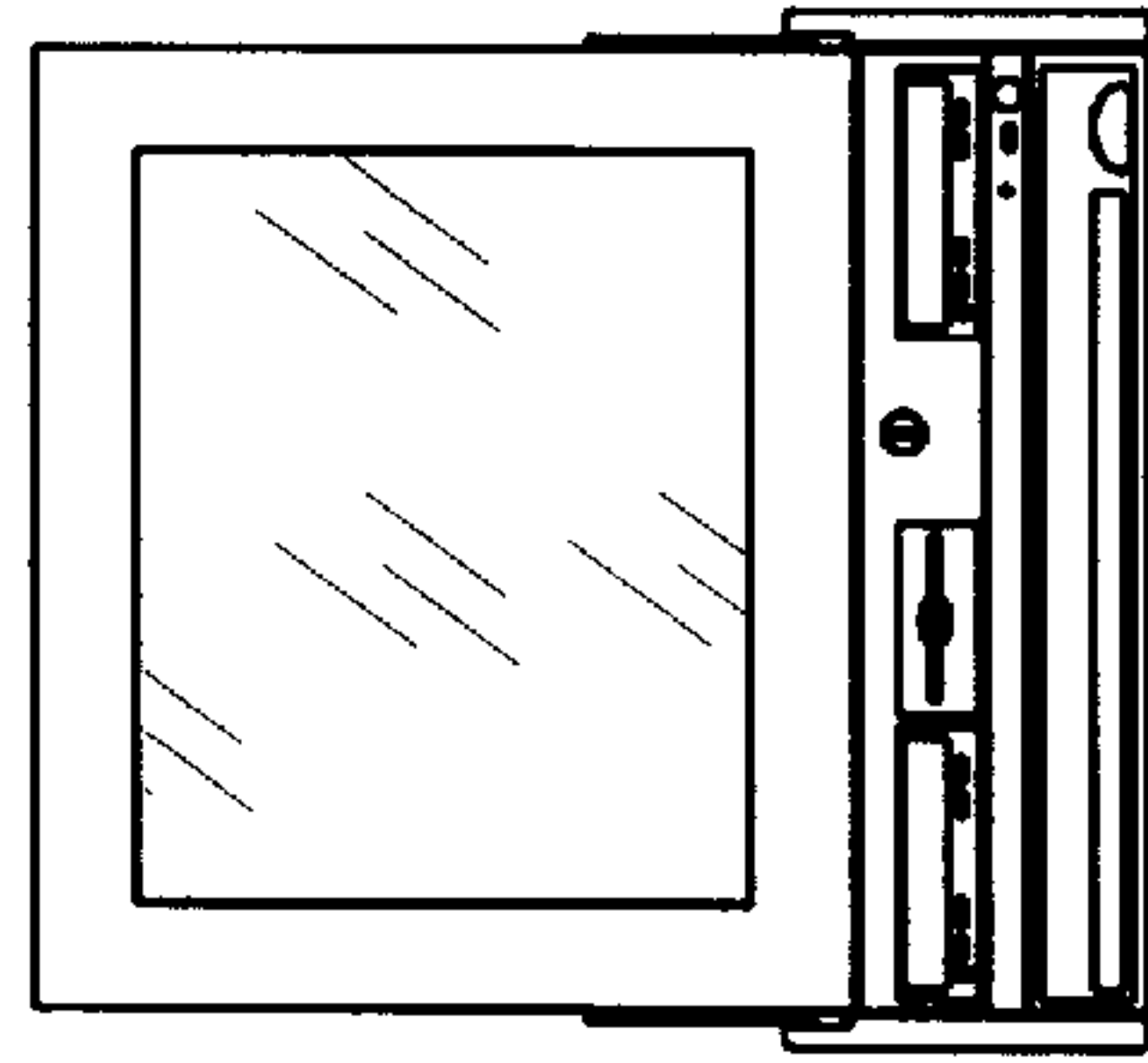
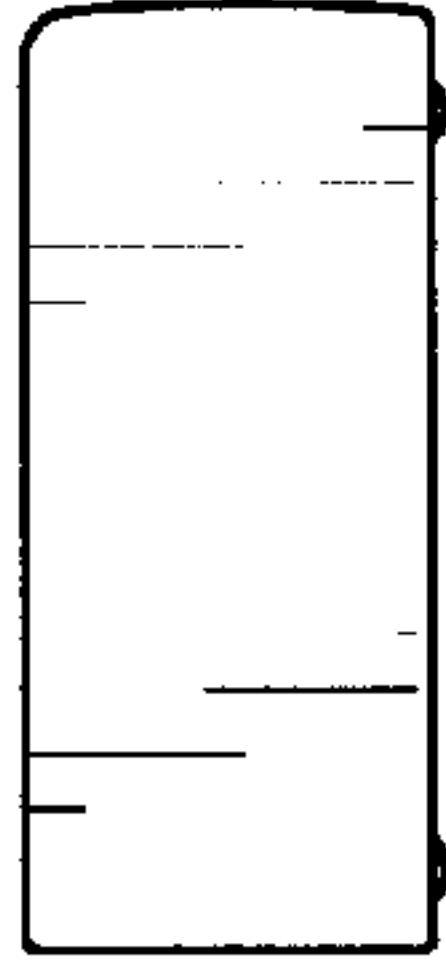

FIG. 9

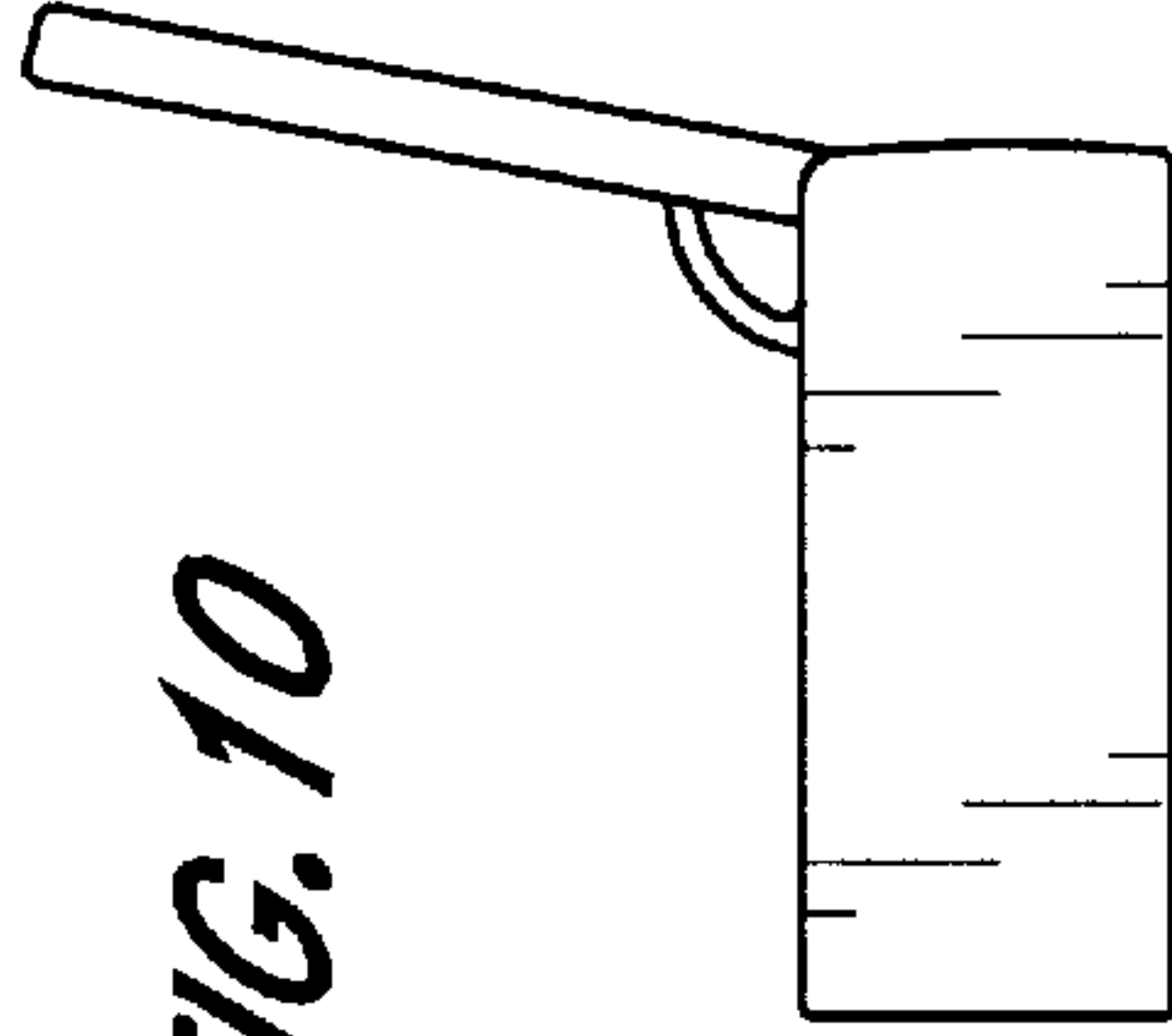

FIG. 10

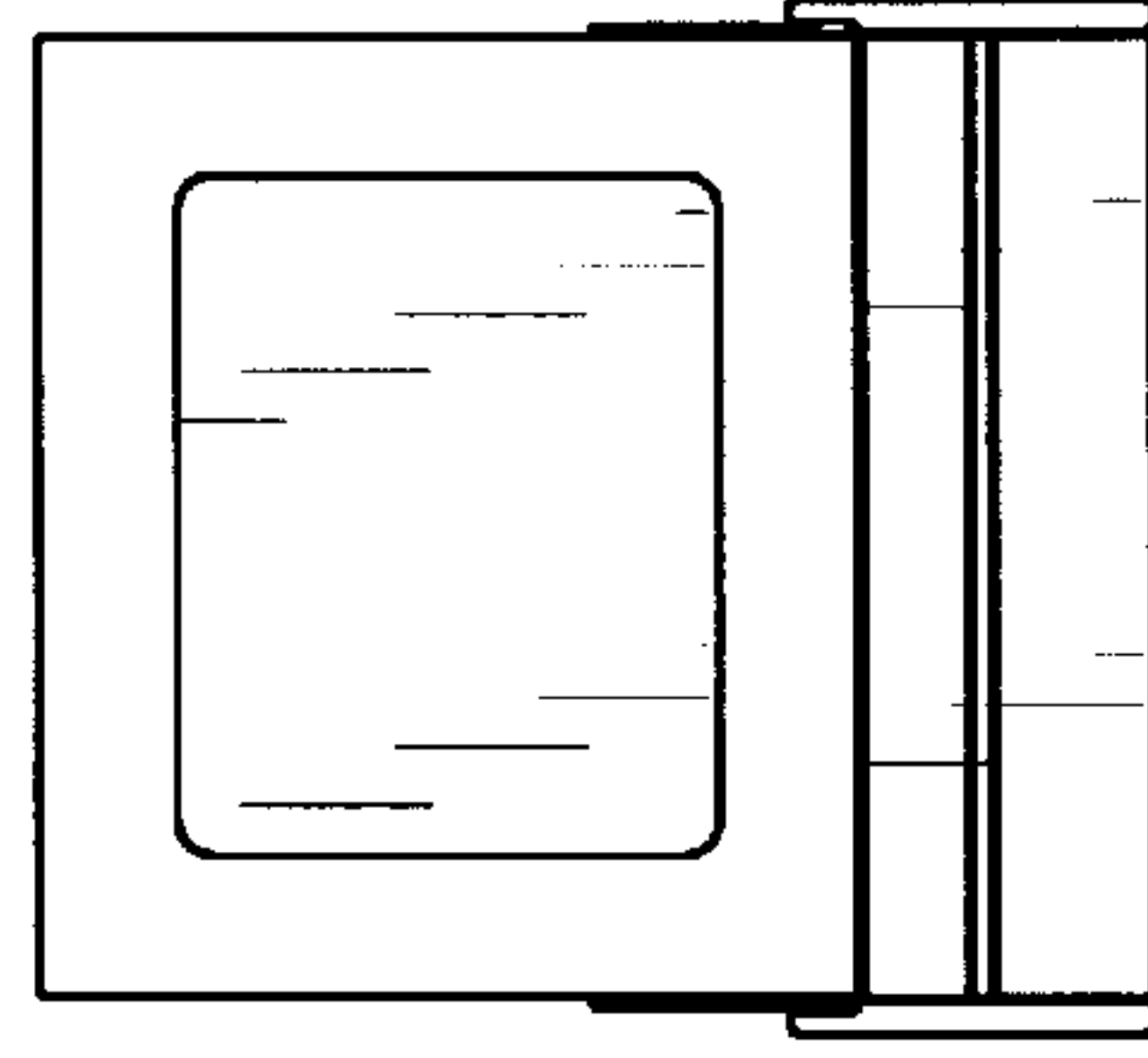

FIG. 14

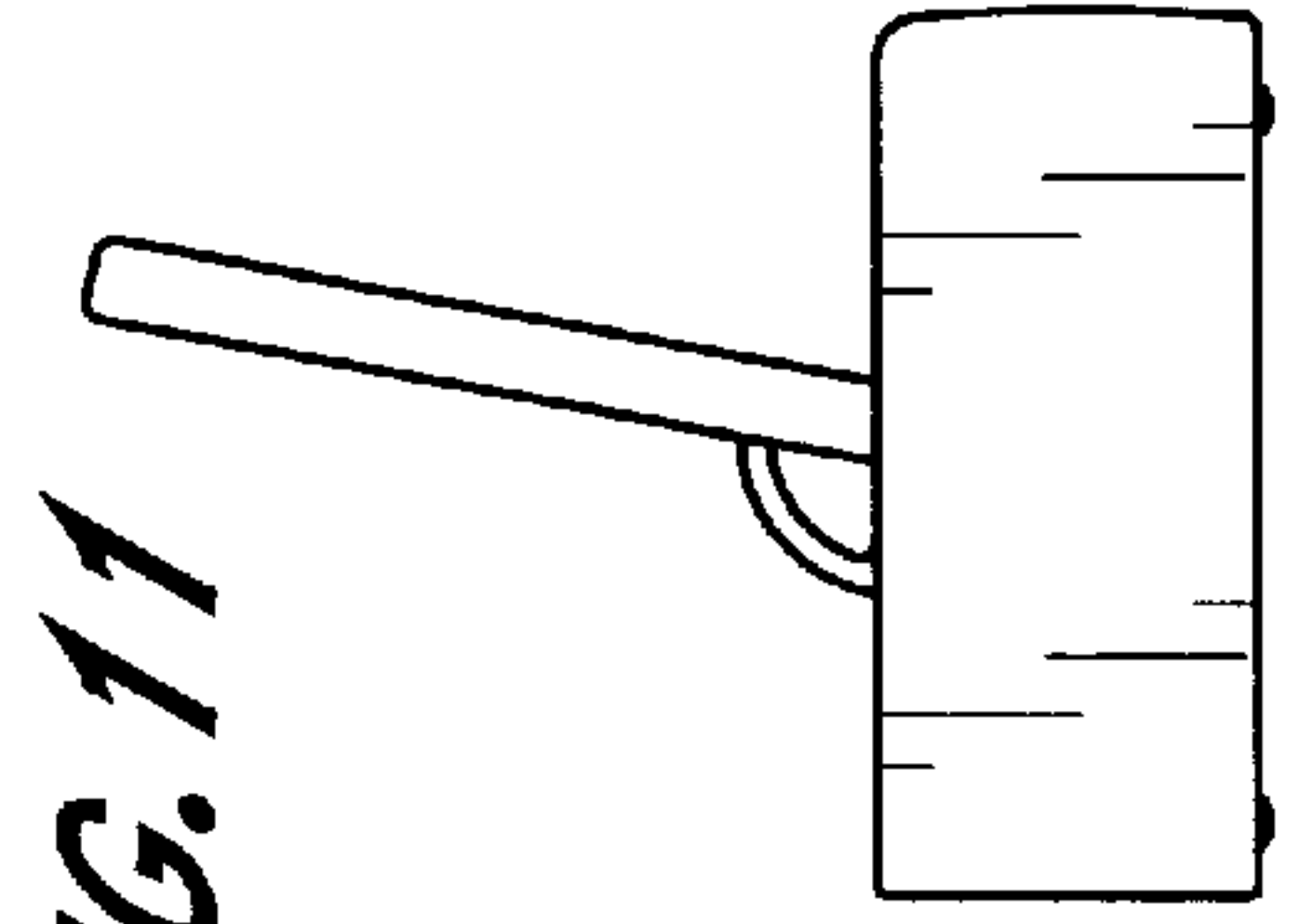

FIG. 11

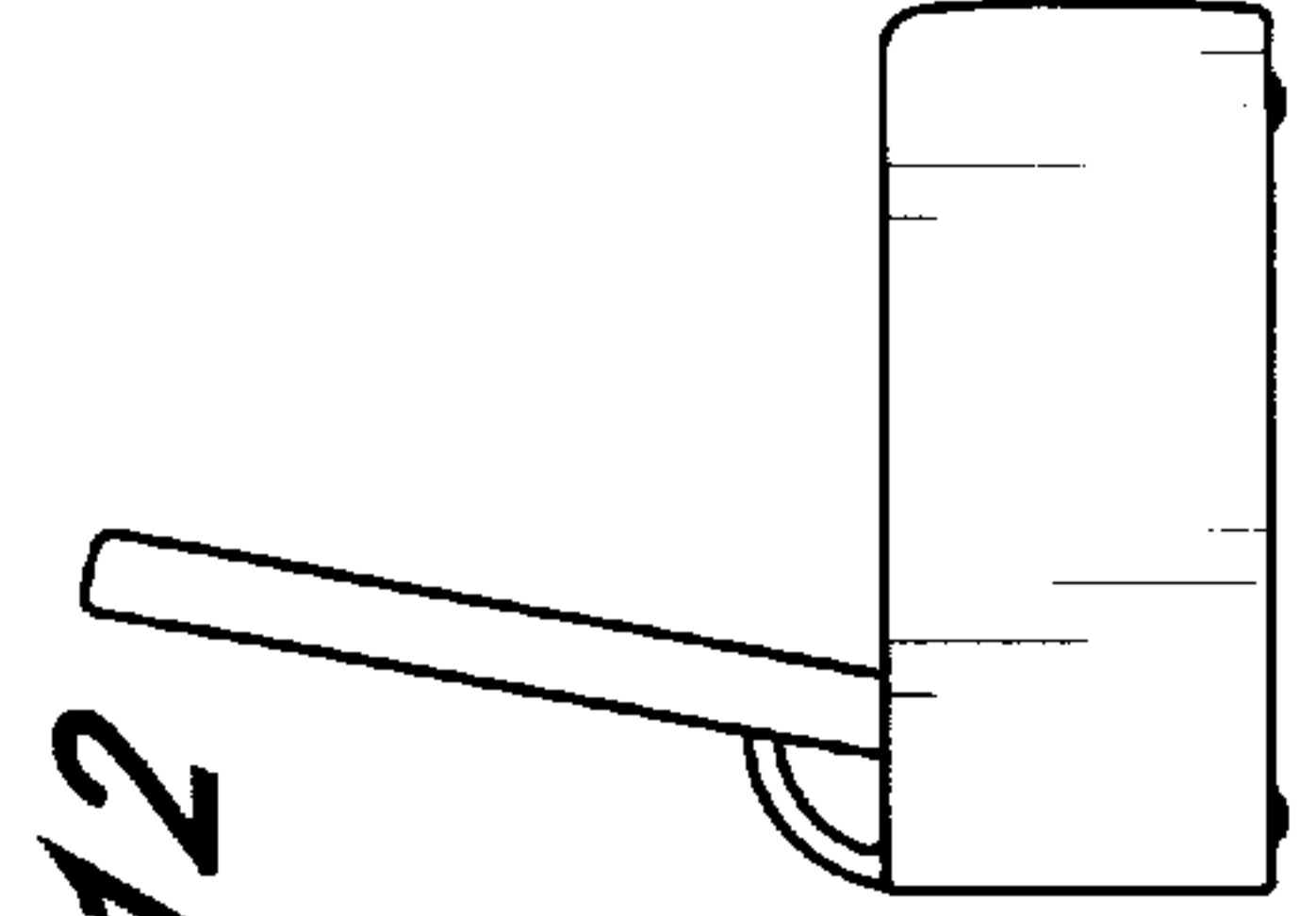

FIG. 12

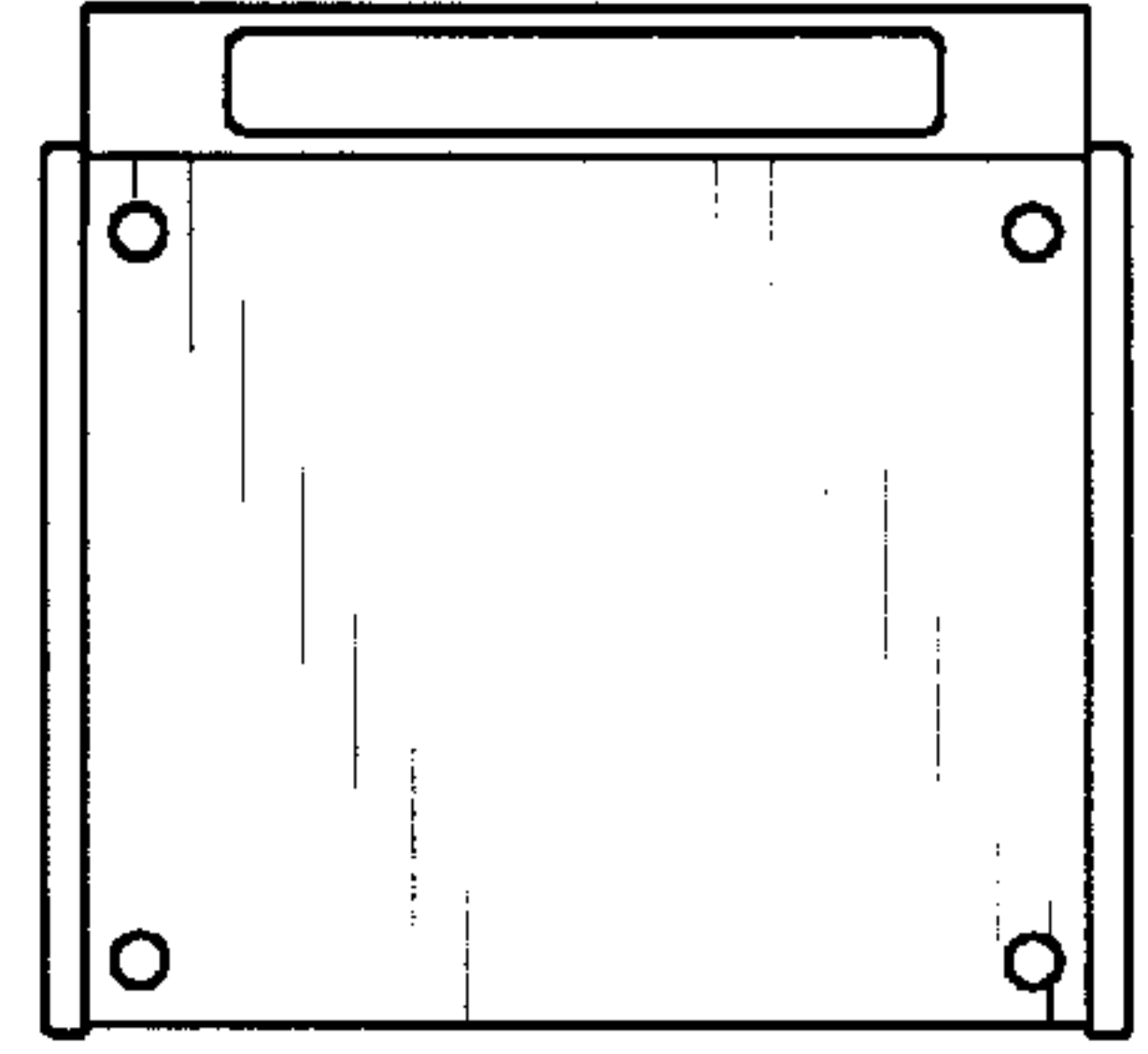

FIG. 16

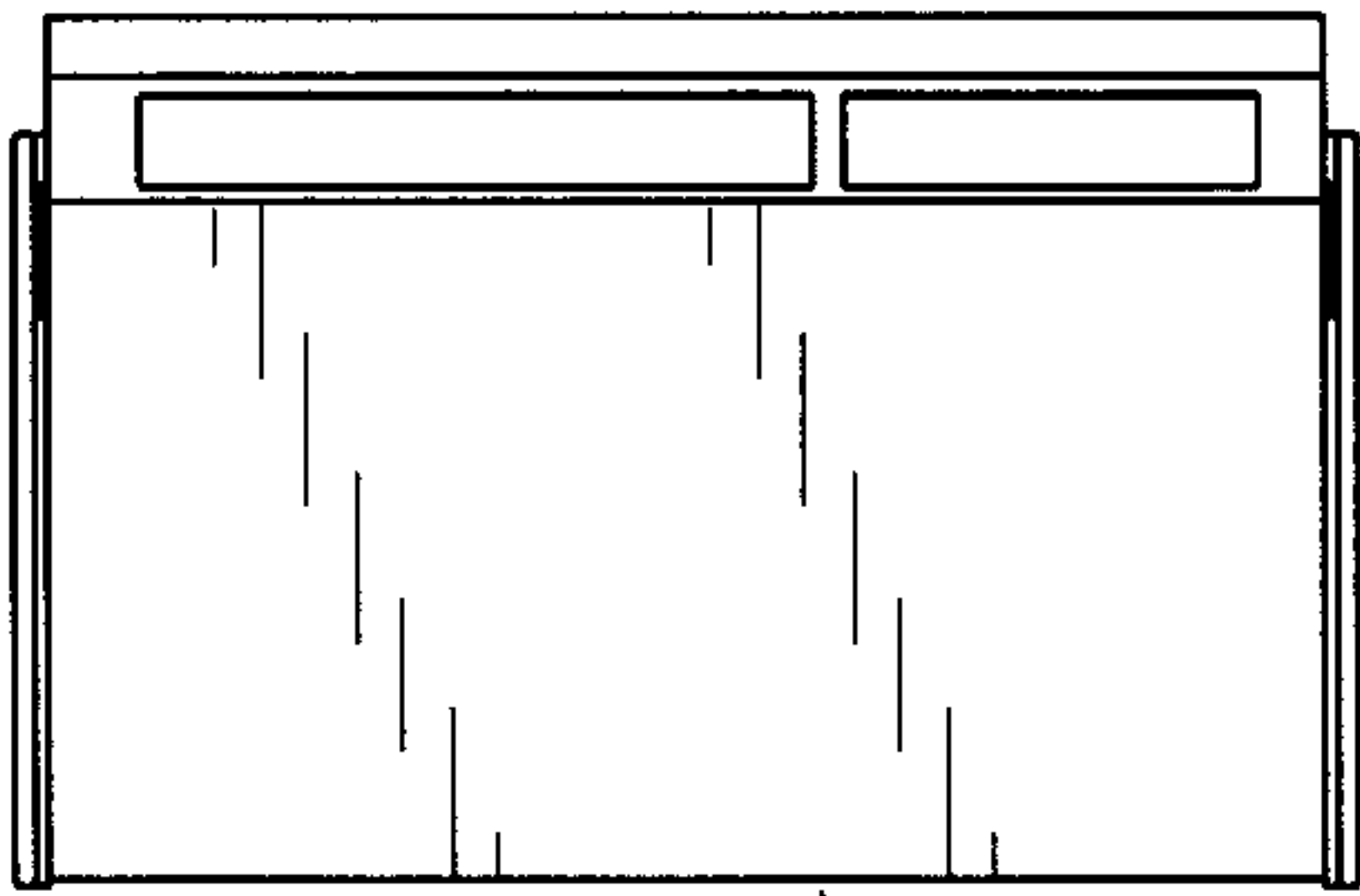

FIG. 23

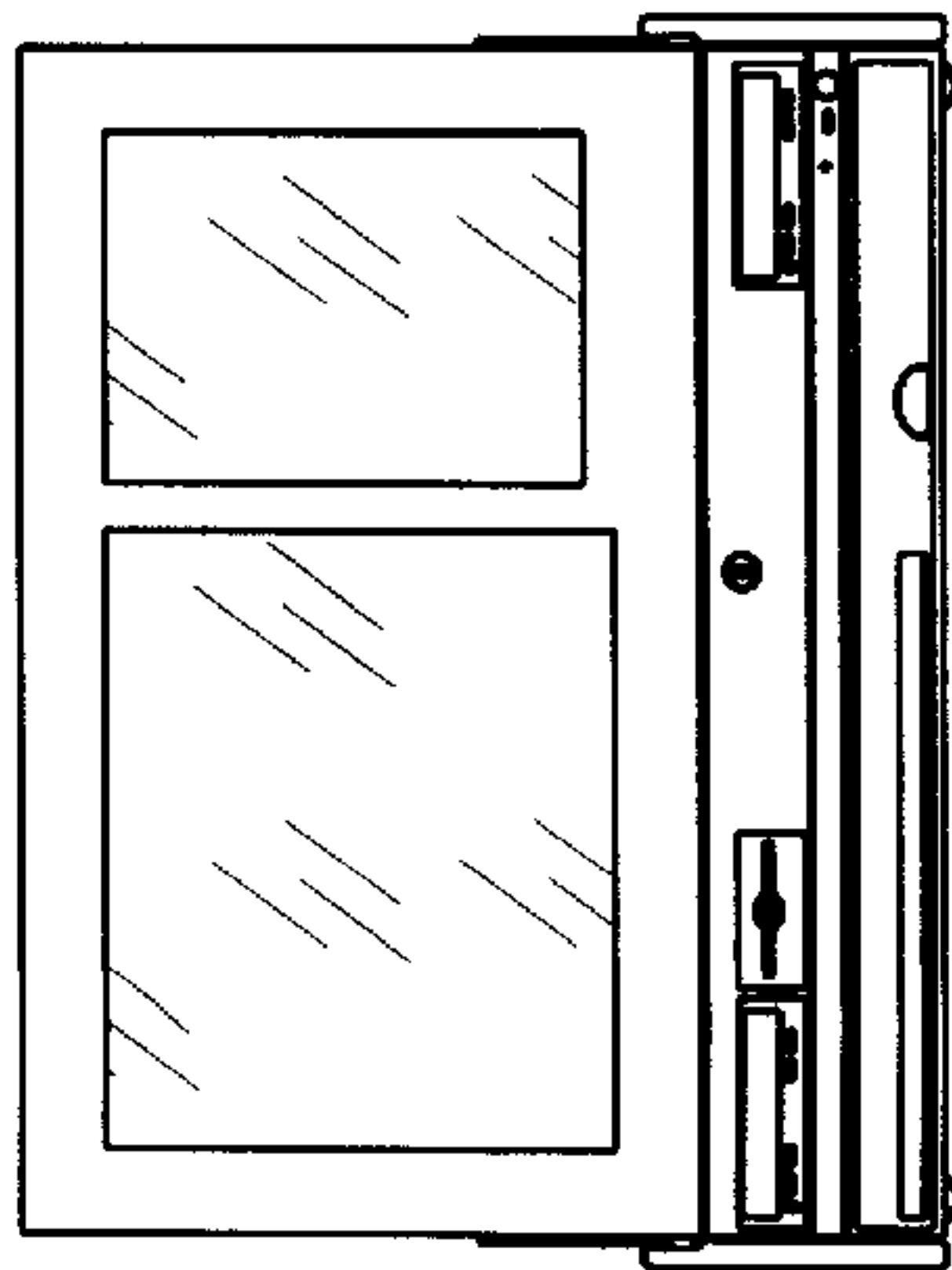

FIG. 17

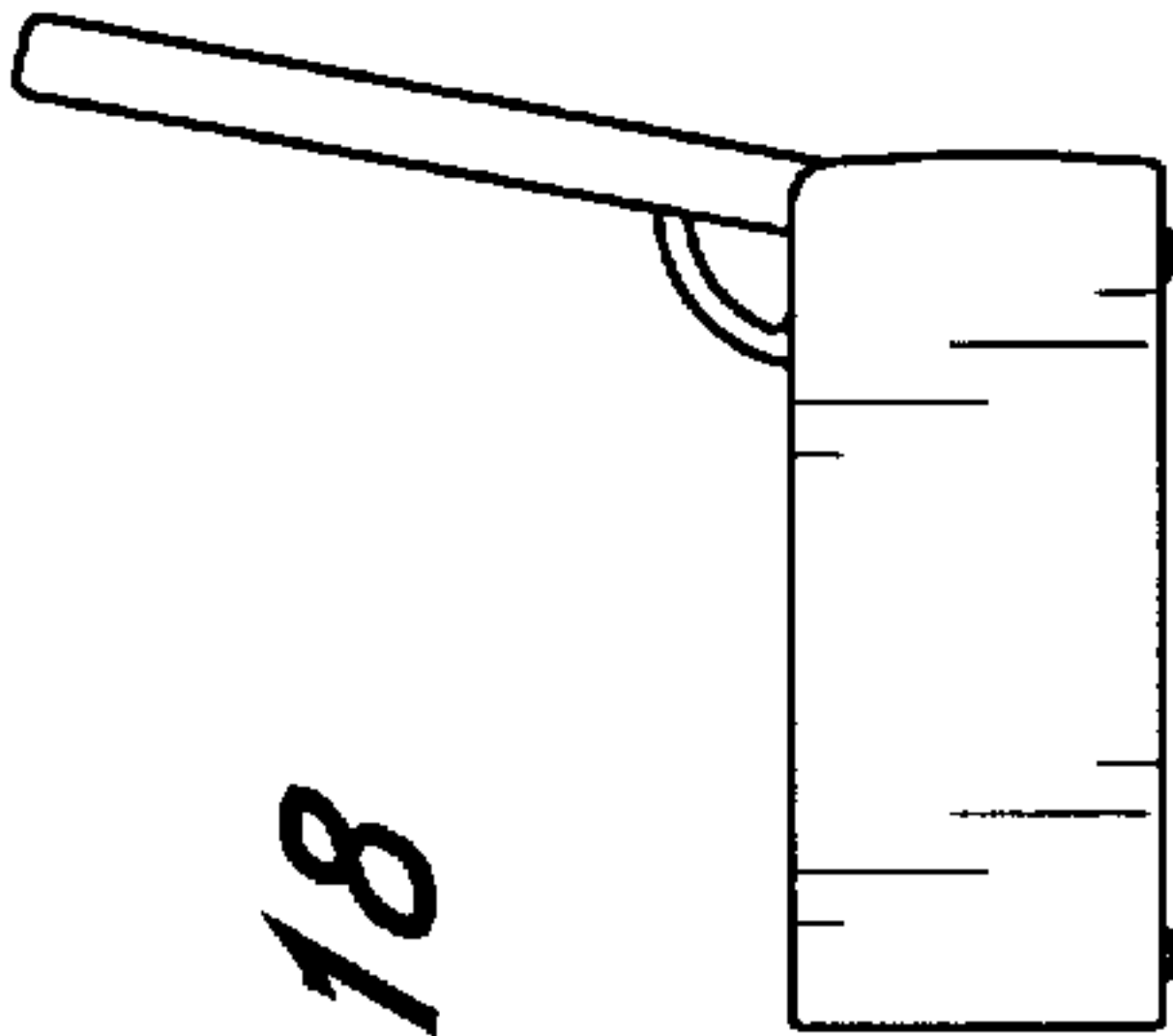

FIG. 18

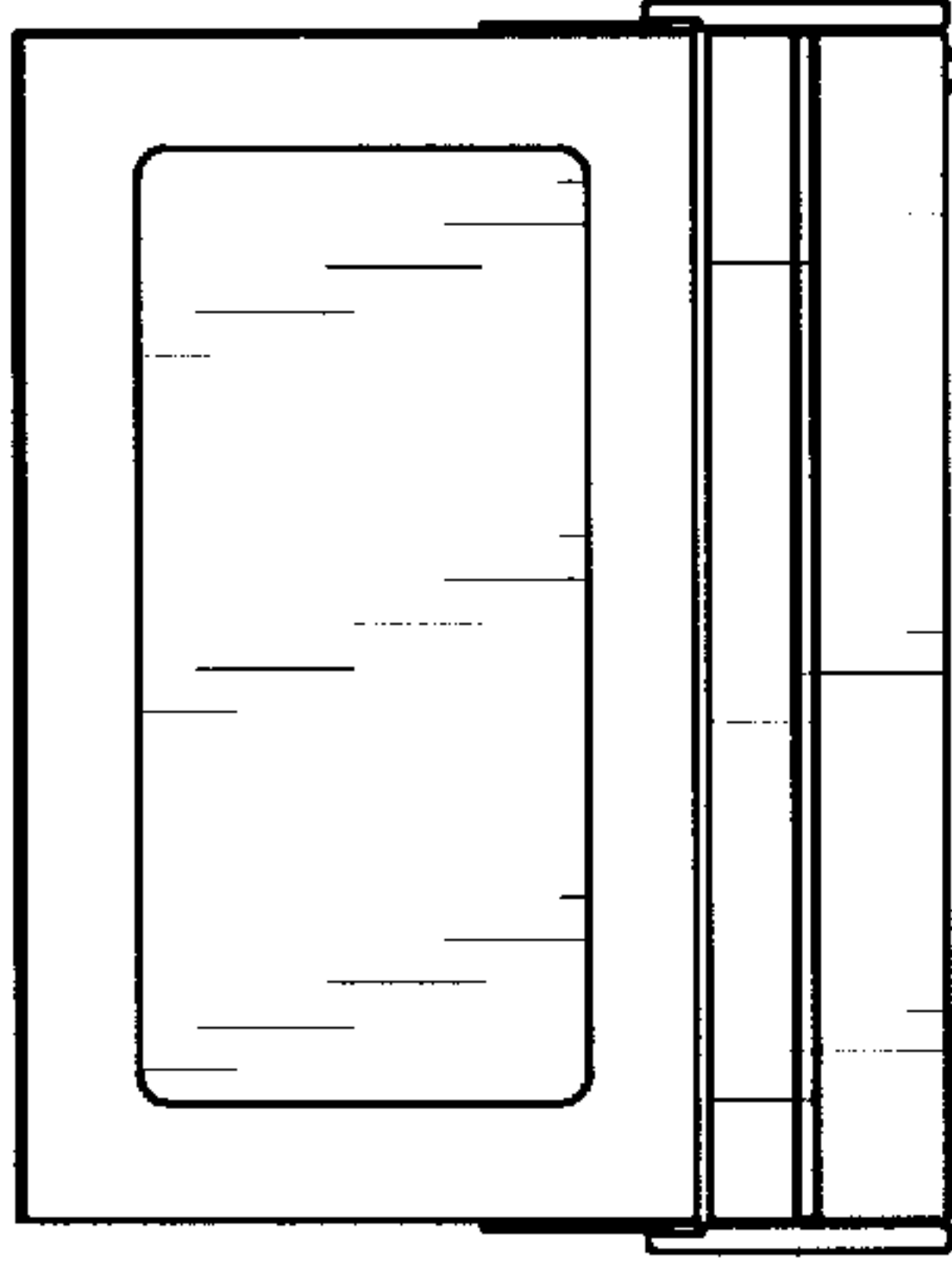

FIG. 22

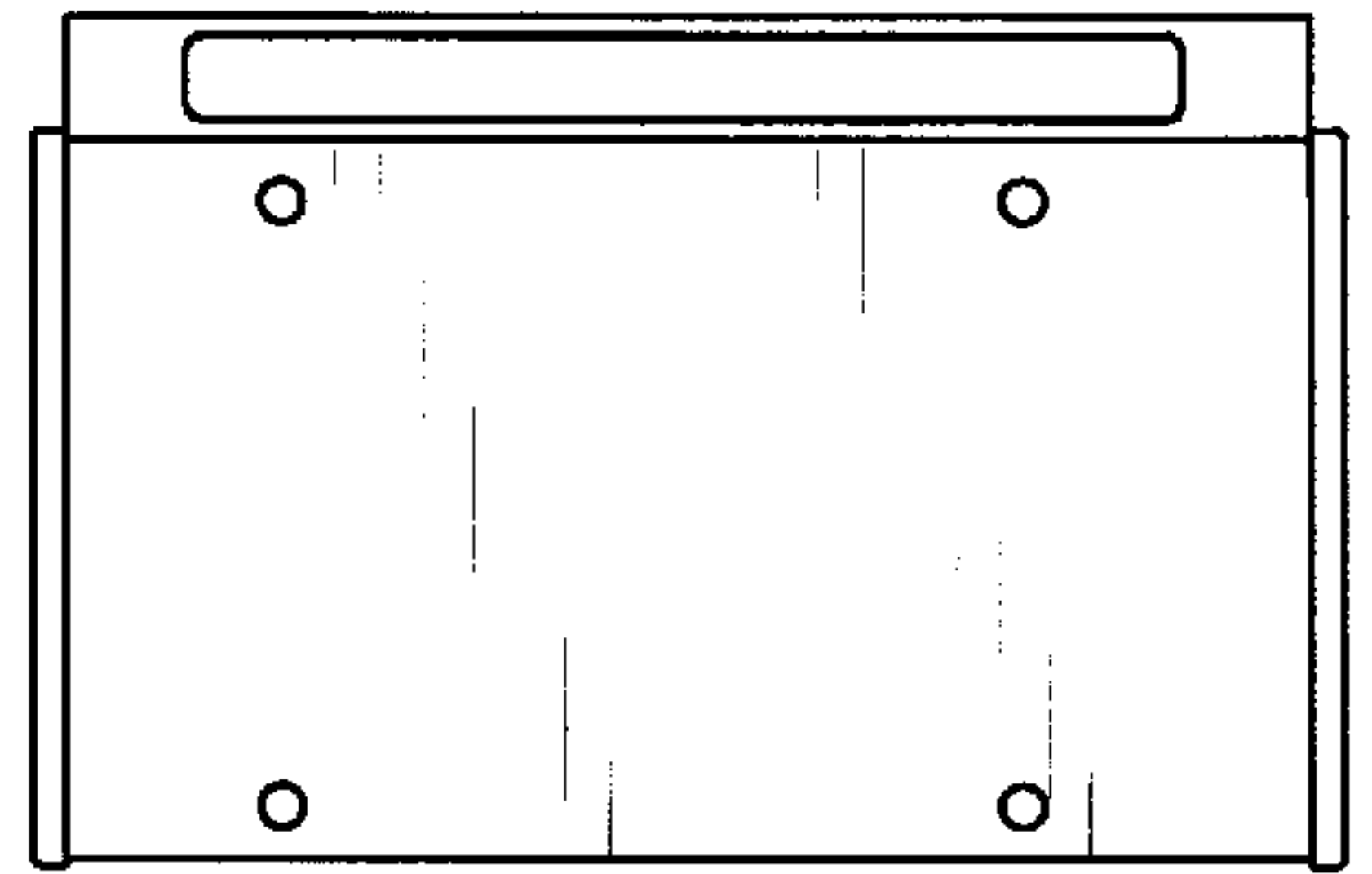

FIG. 24

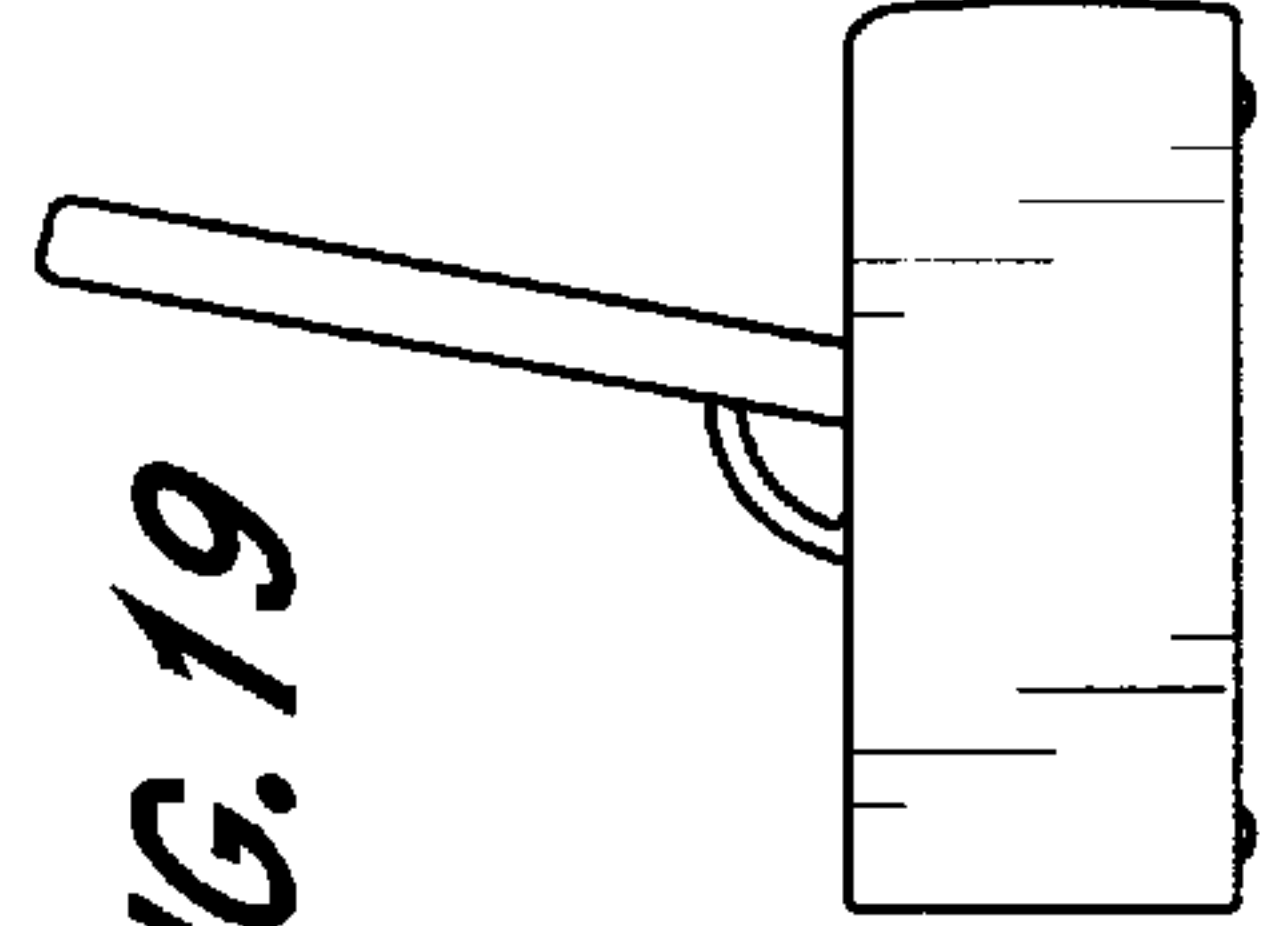

FIG. 19

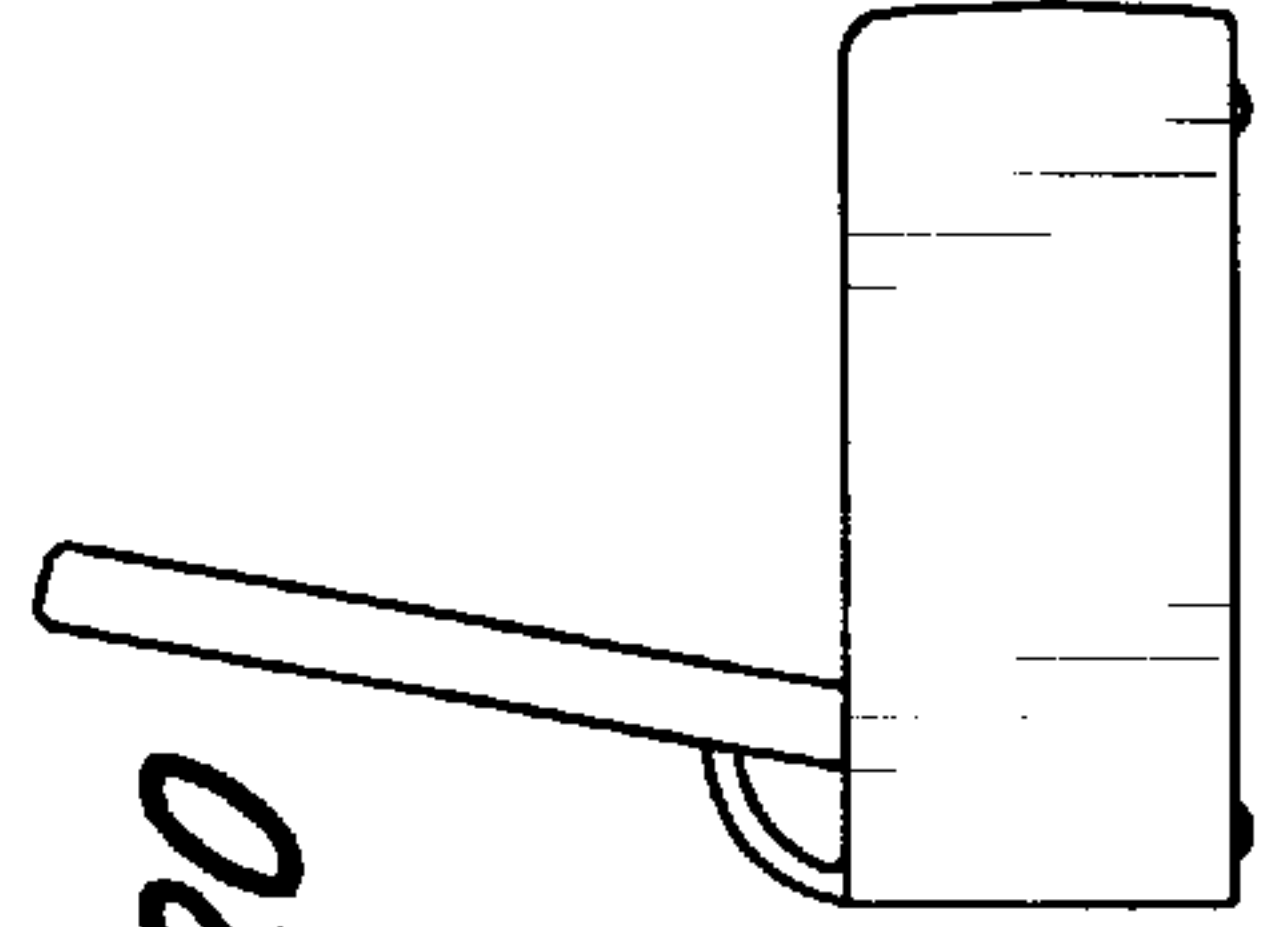

FIG. 20

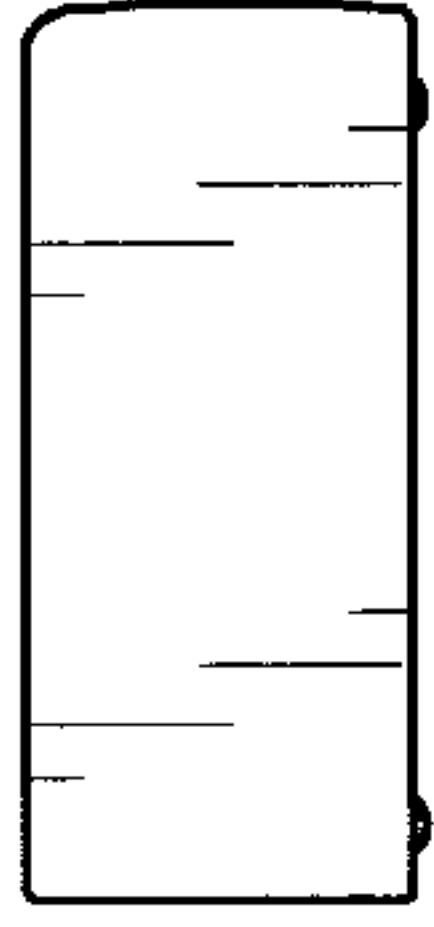

FIG. 21

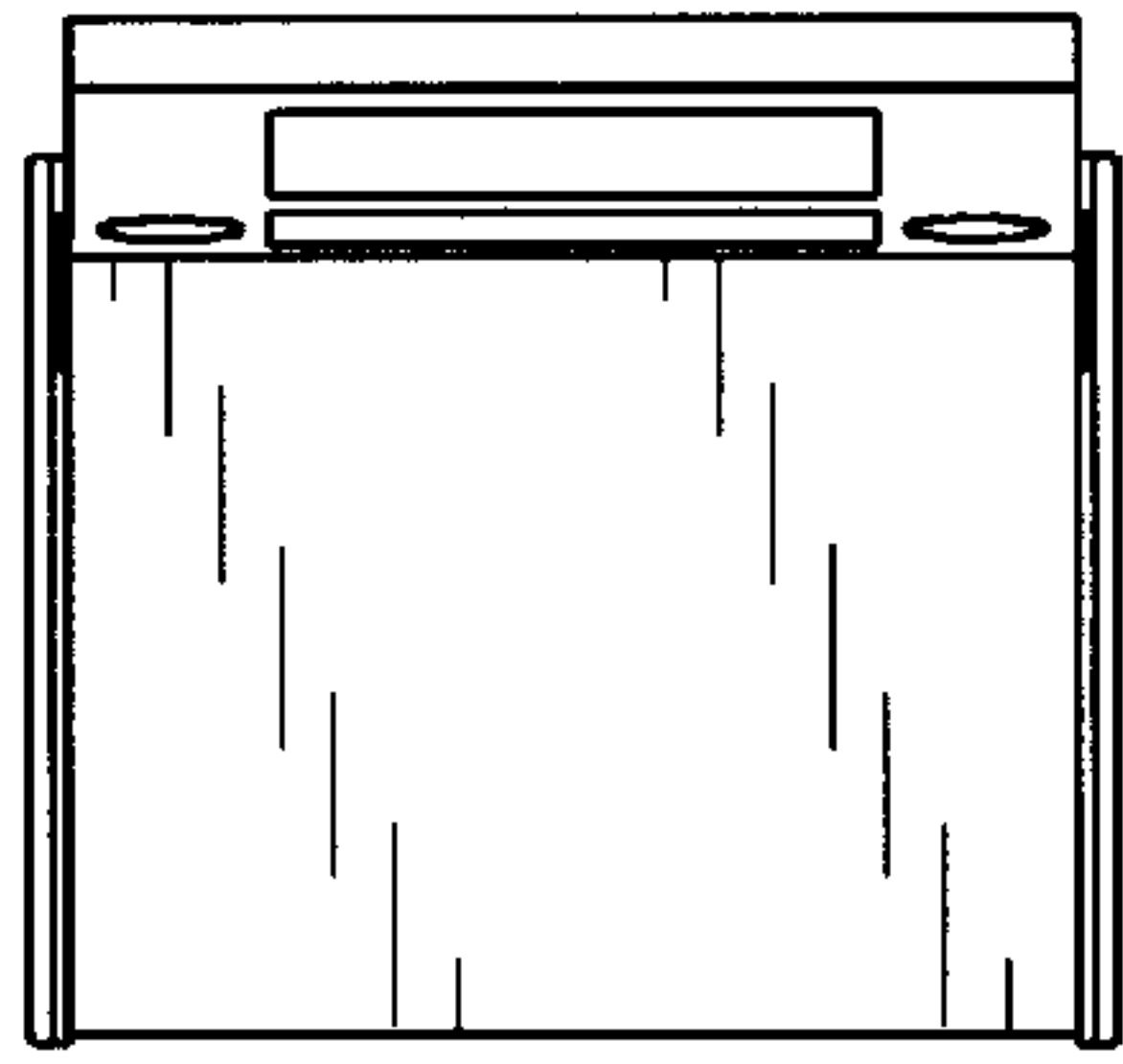

FIG. 31

FIG. 29

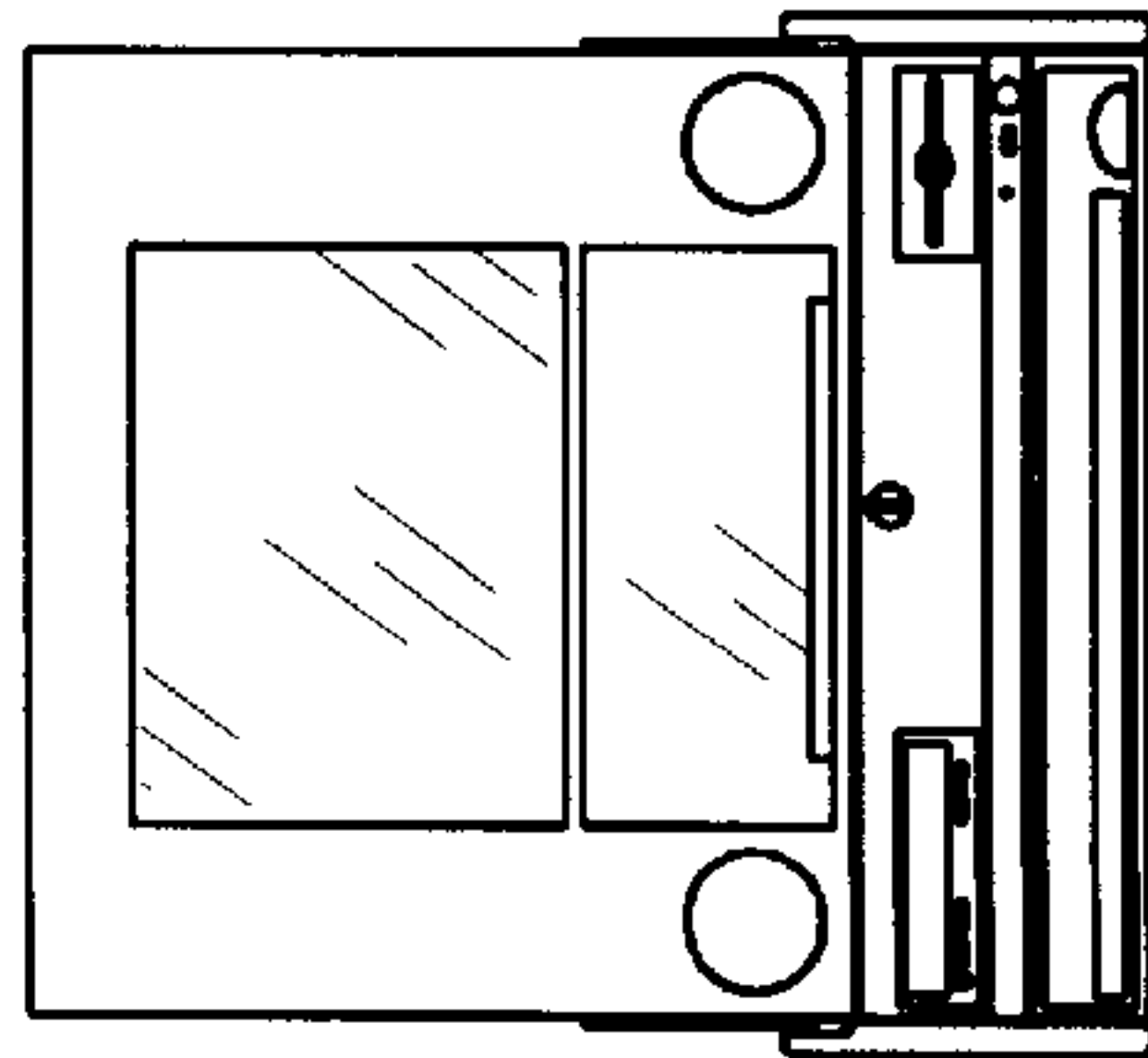
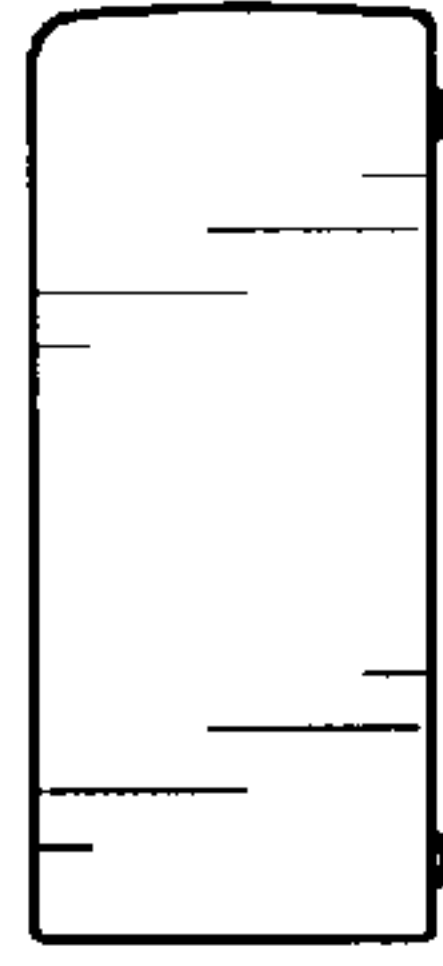

FIG. 25

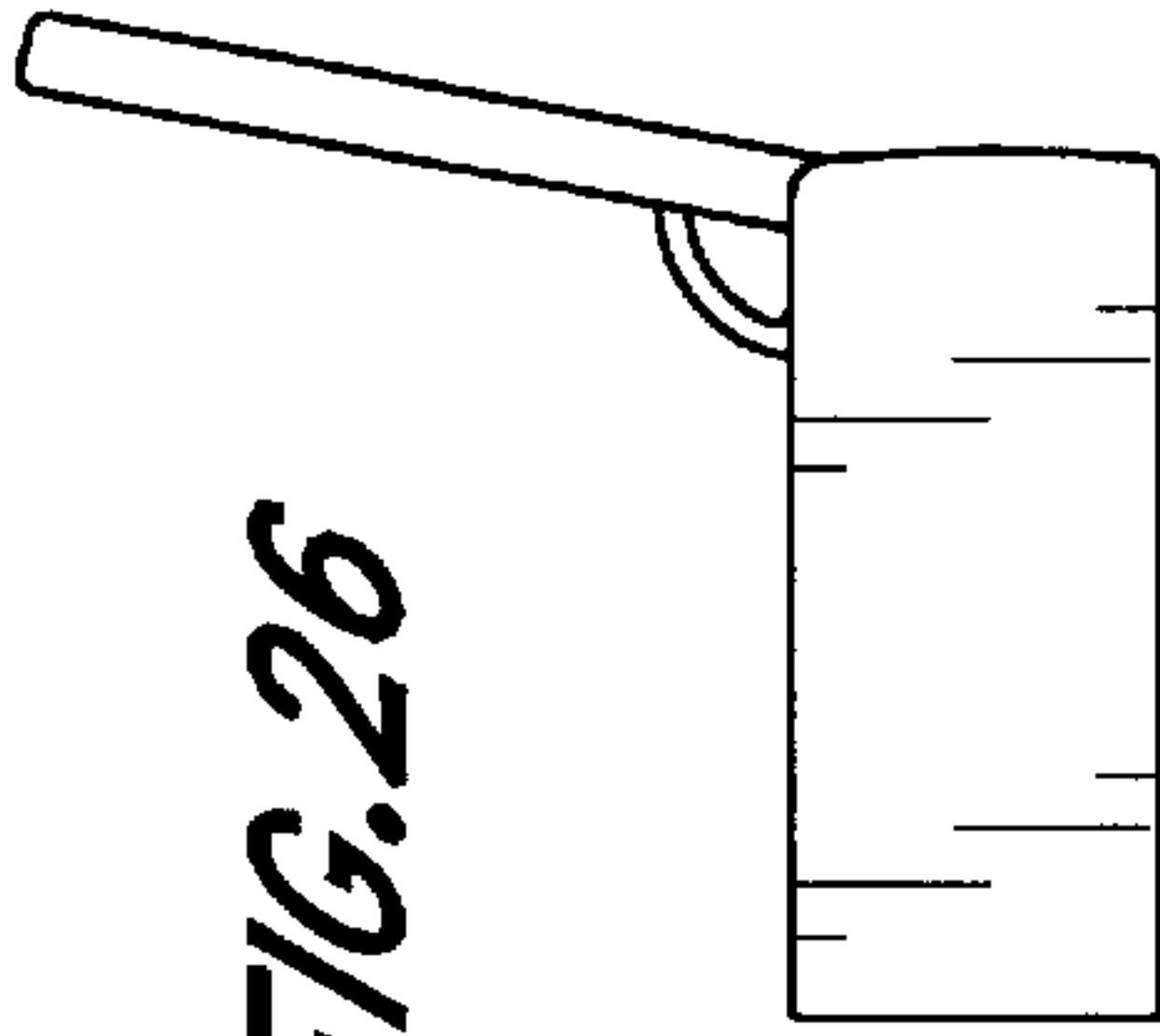

FIG. 26

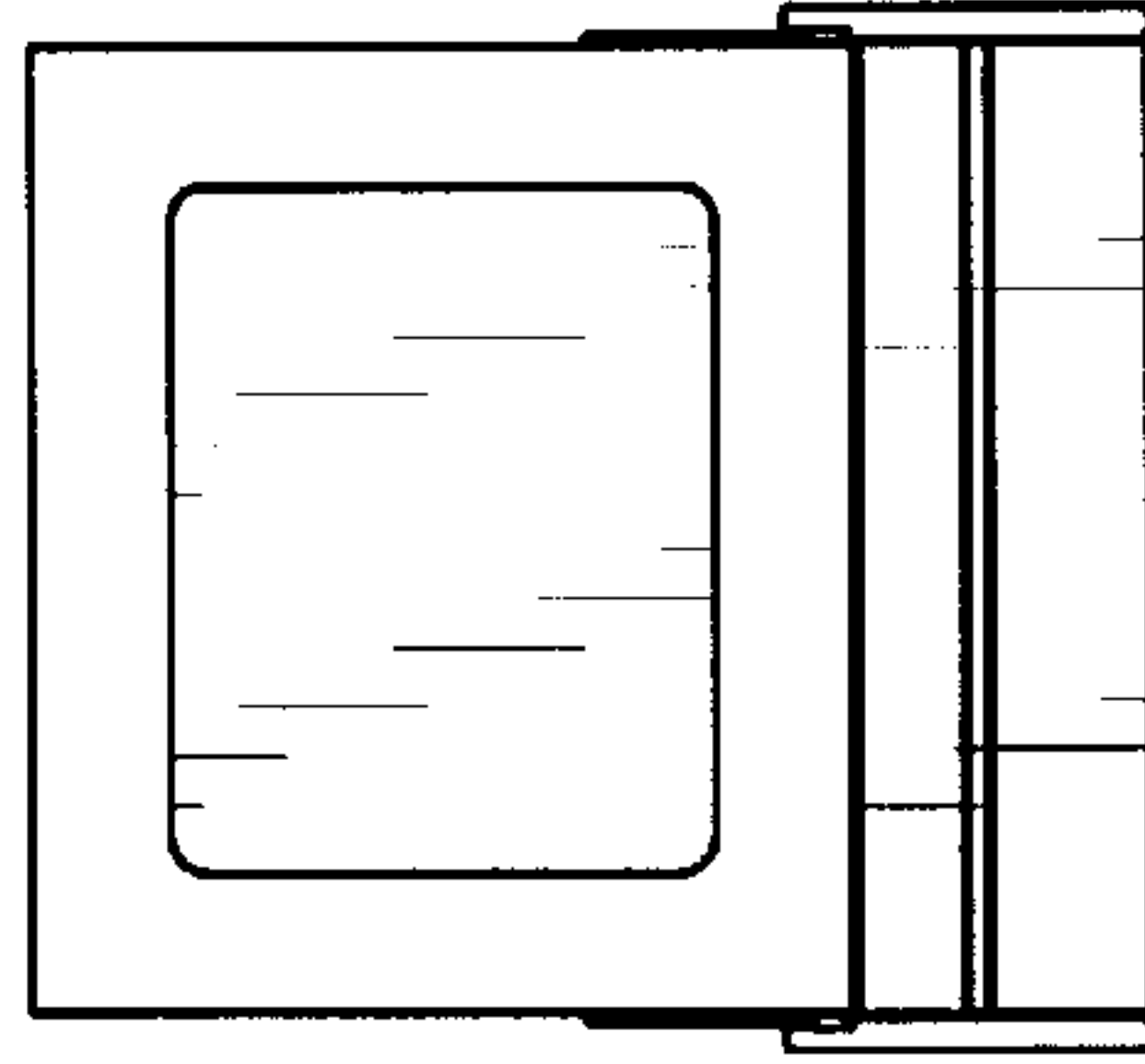

FIG. 30

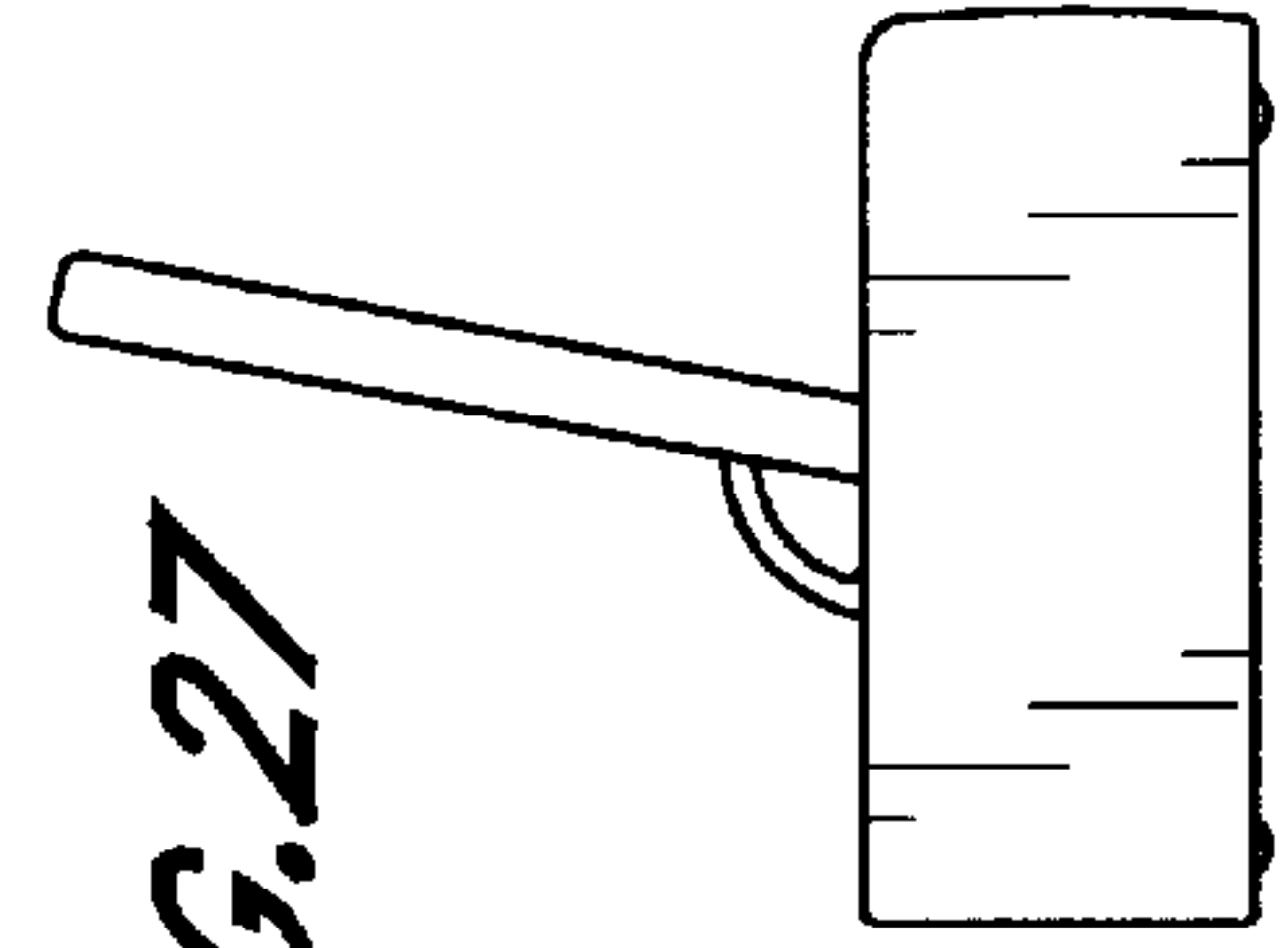

FIG. 27

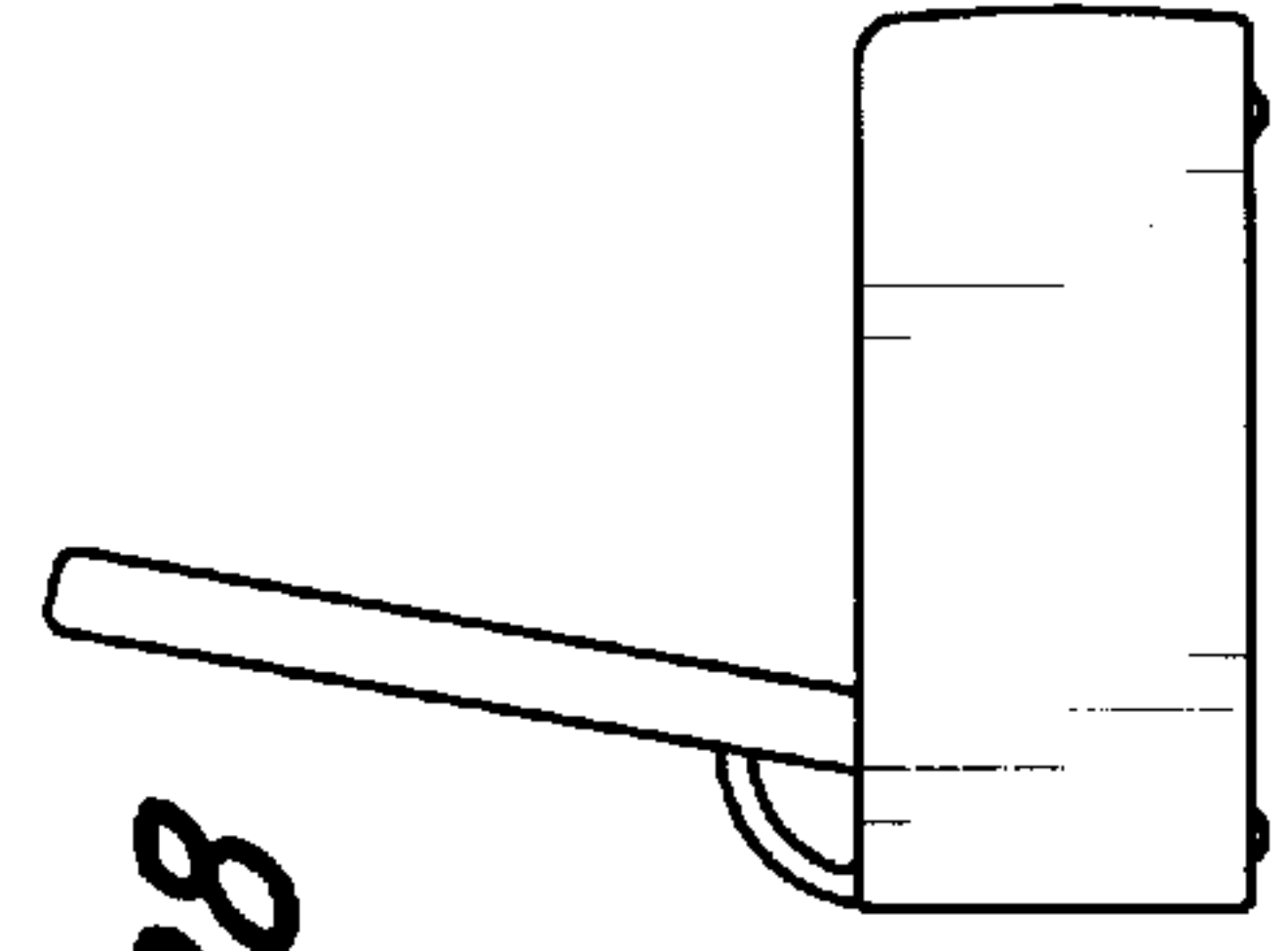

FIG. 28

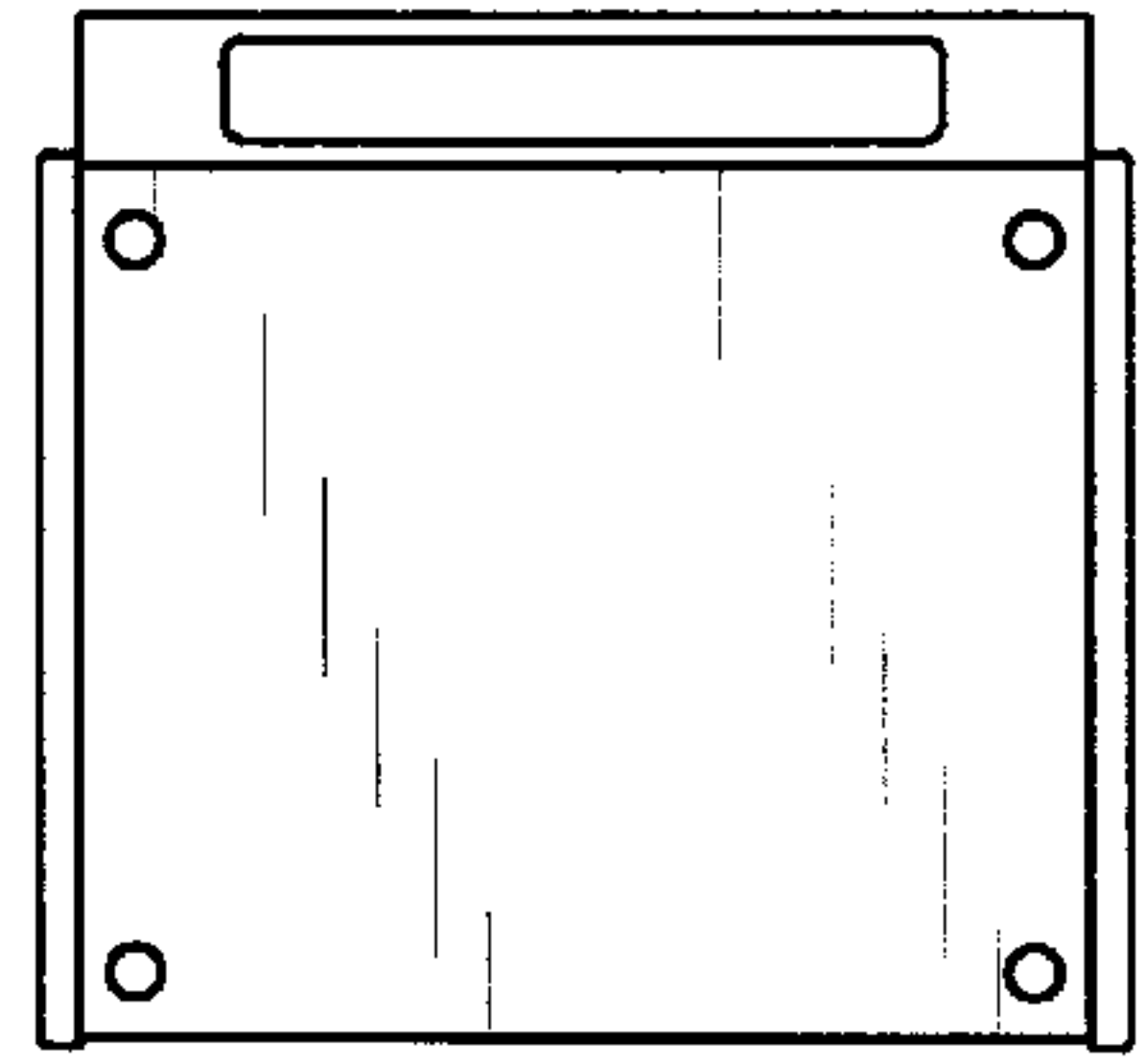

FIG. 32



FIG. 39

FIG. 37

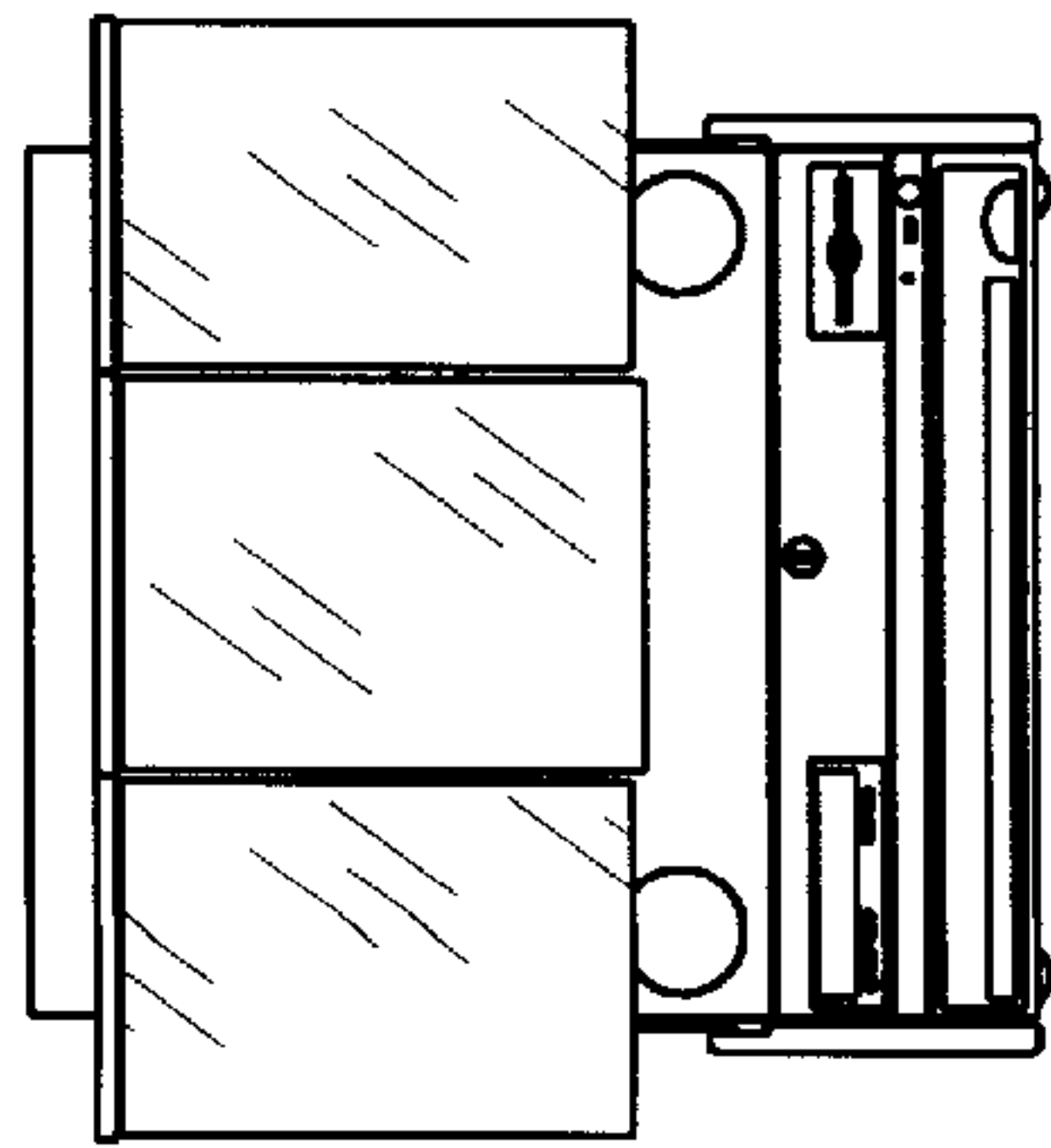
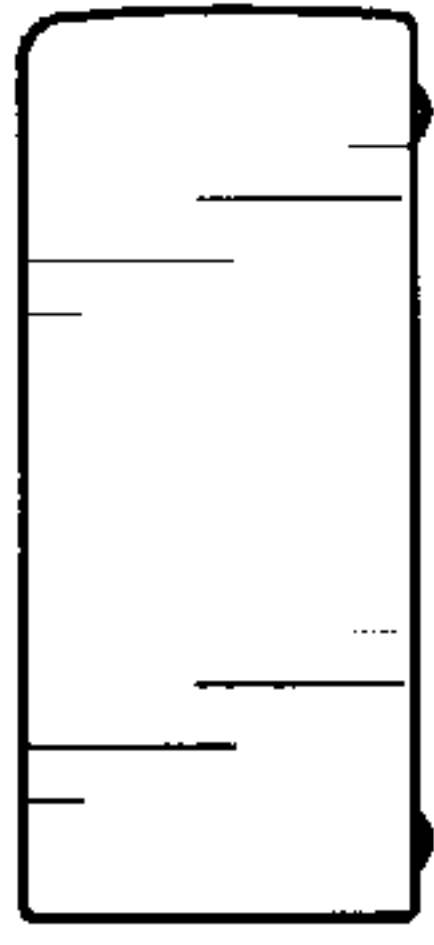

FIG. 33

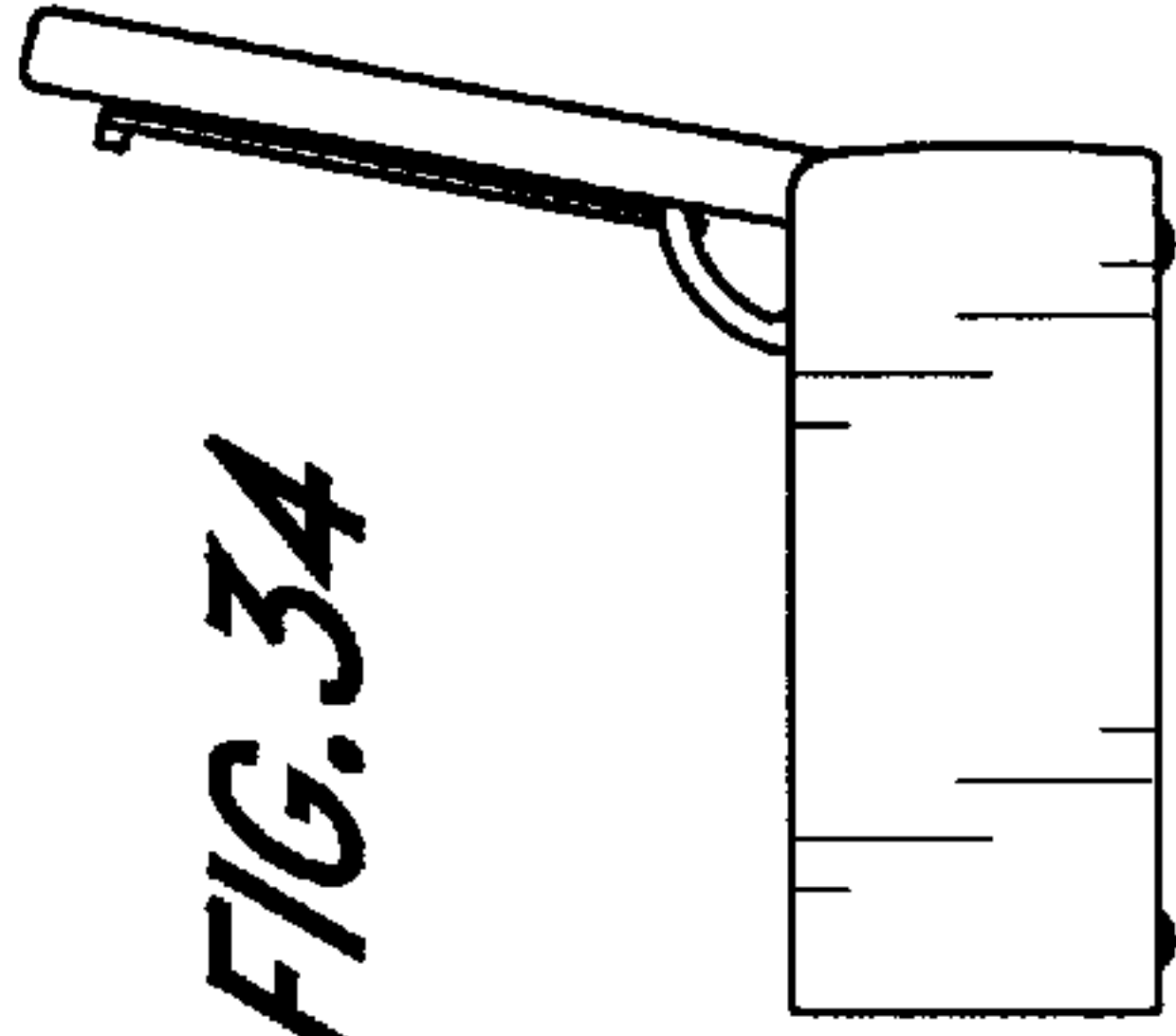

FIG. 34

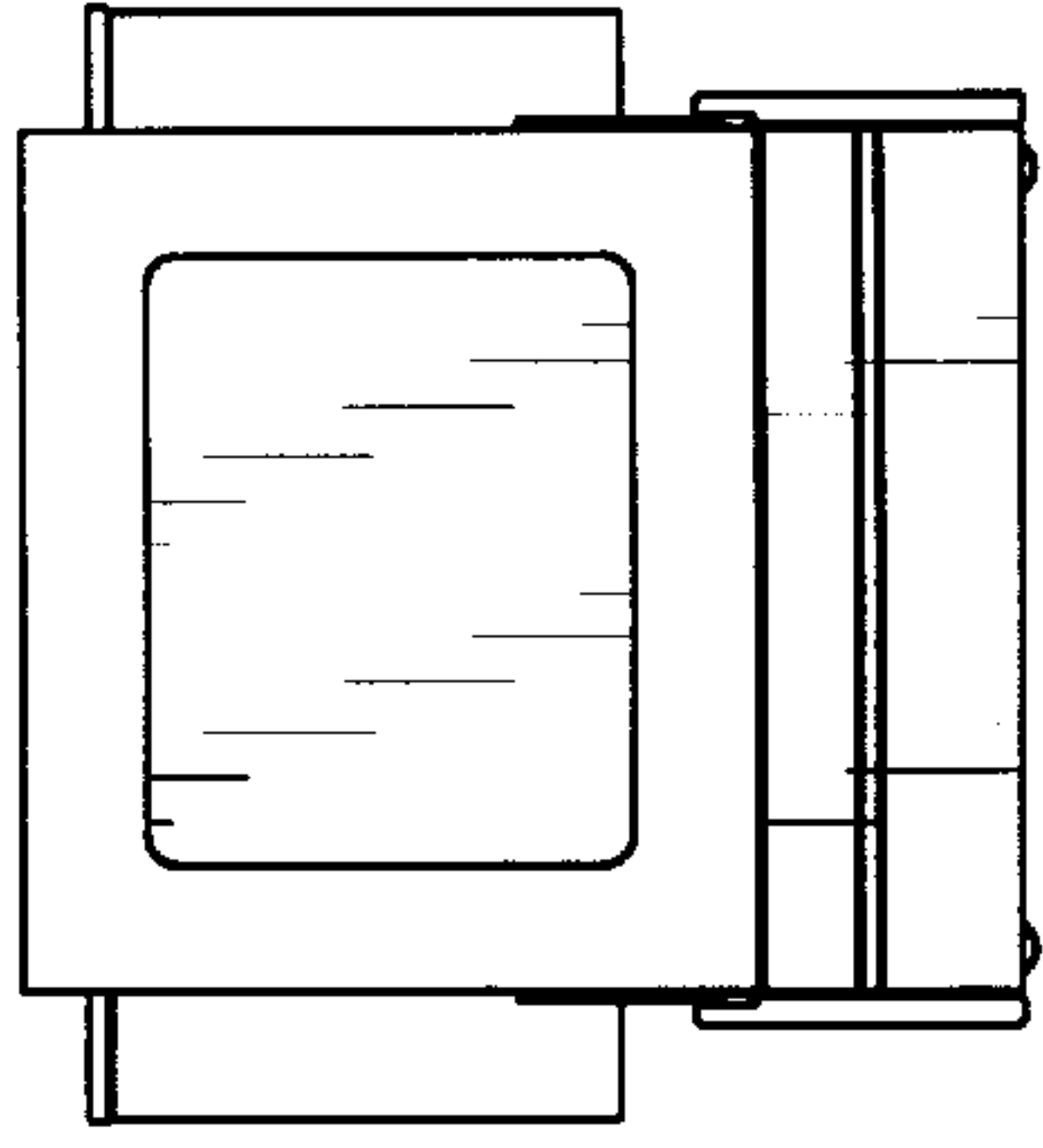

FIG. 38

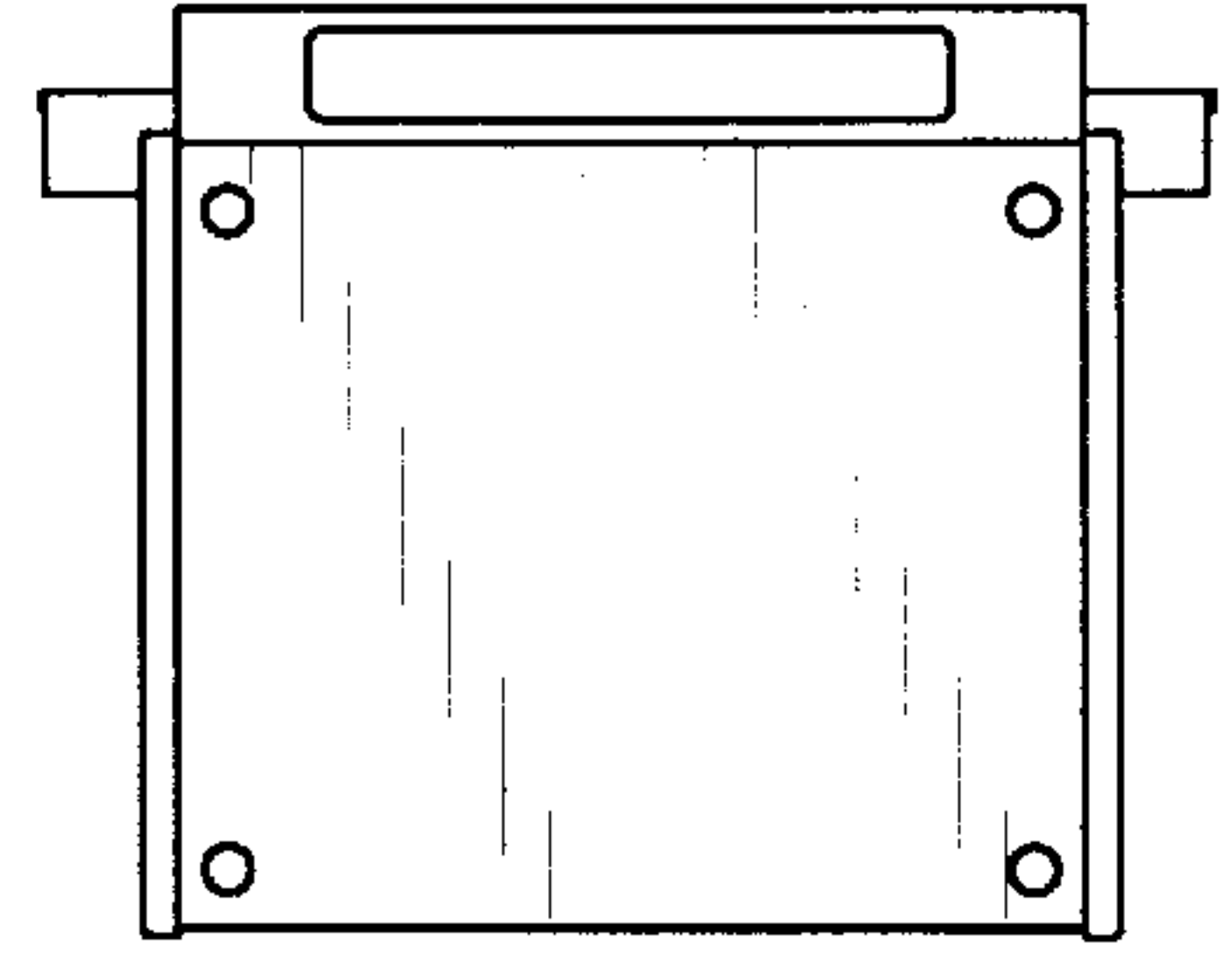

FIG. 40

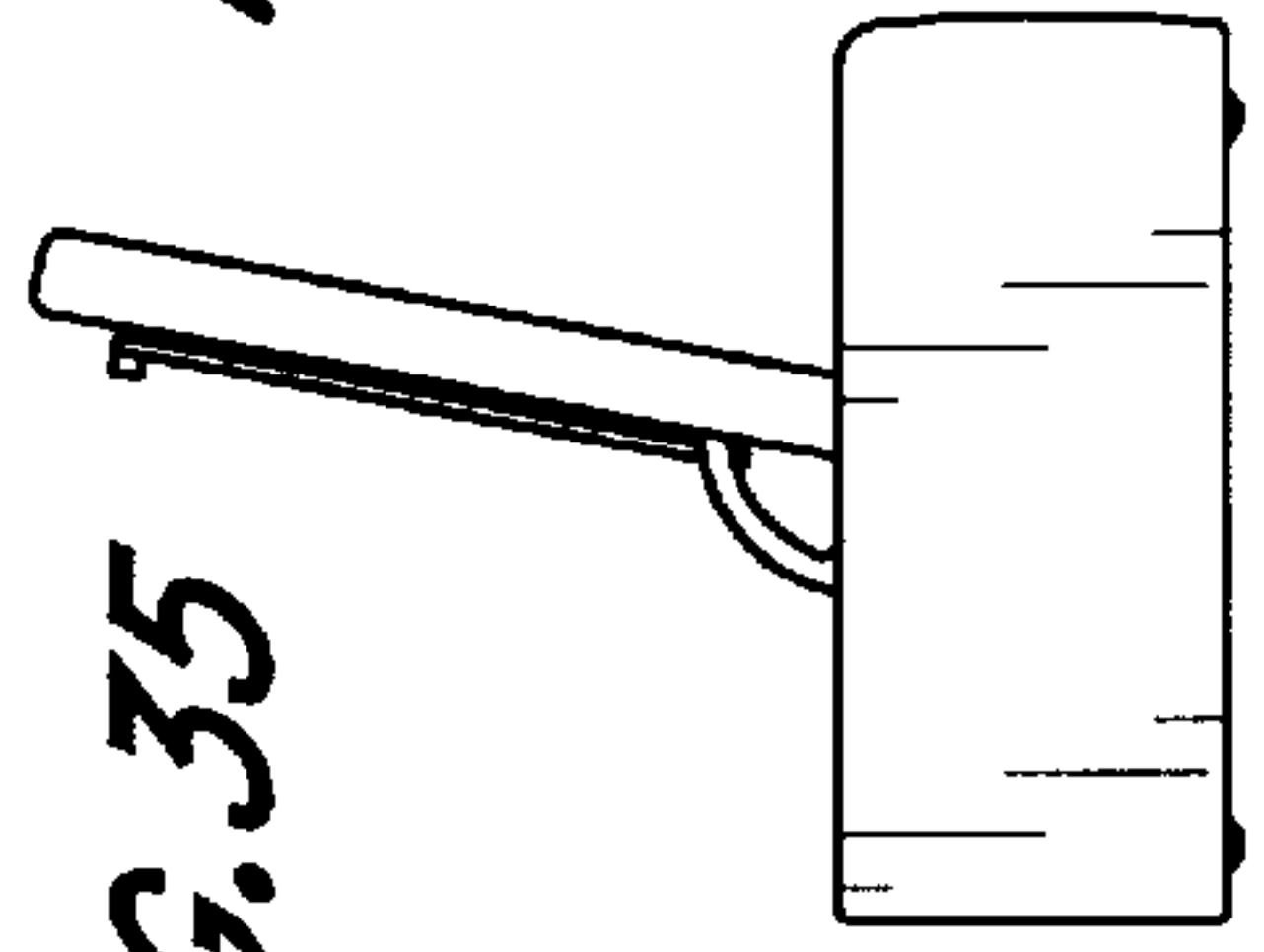

FIG. 35

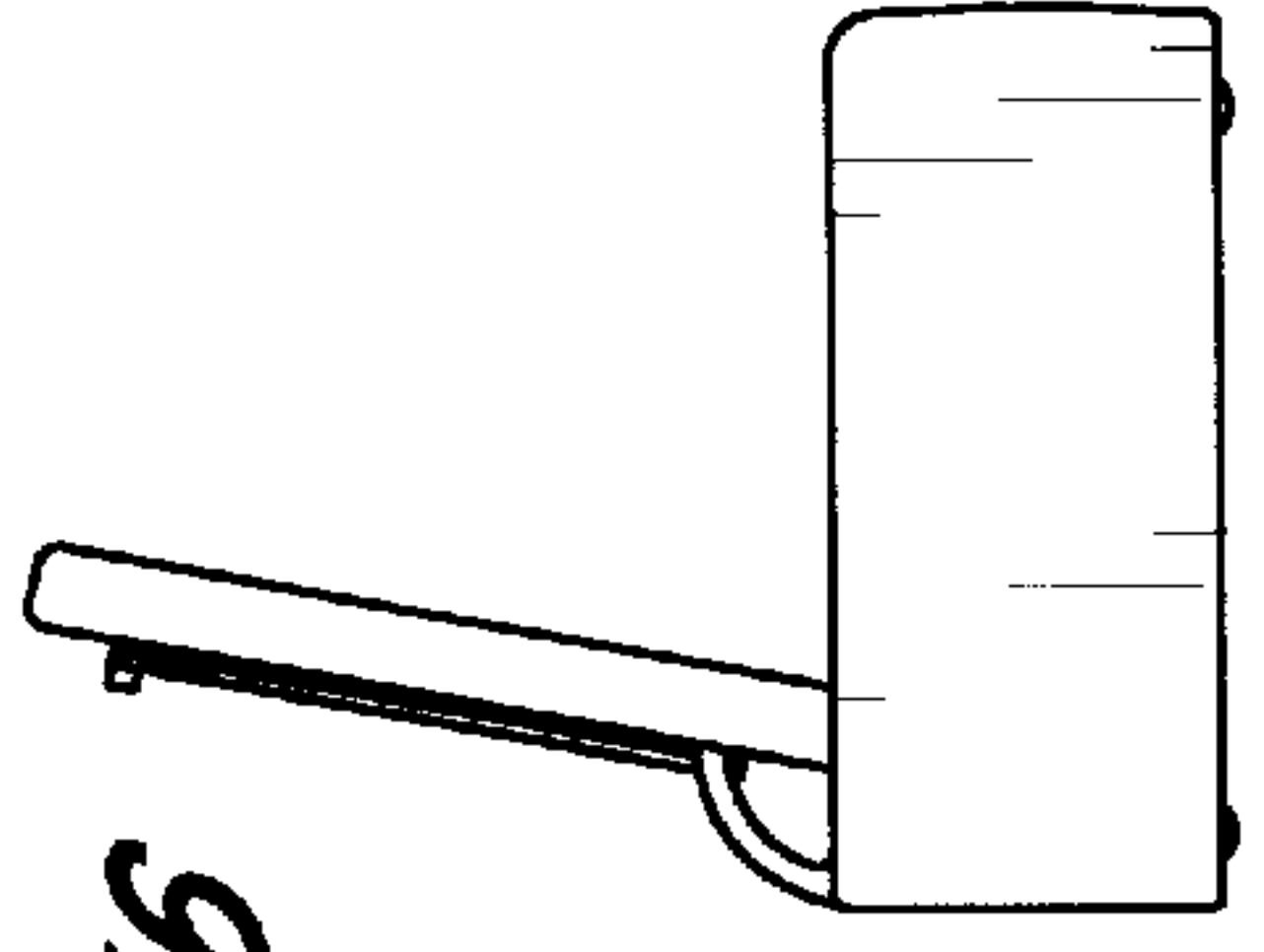

FIG. 36

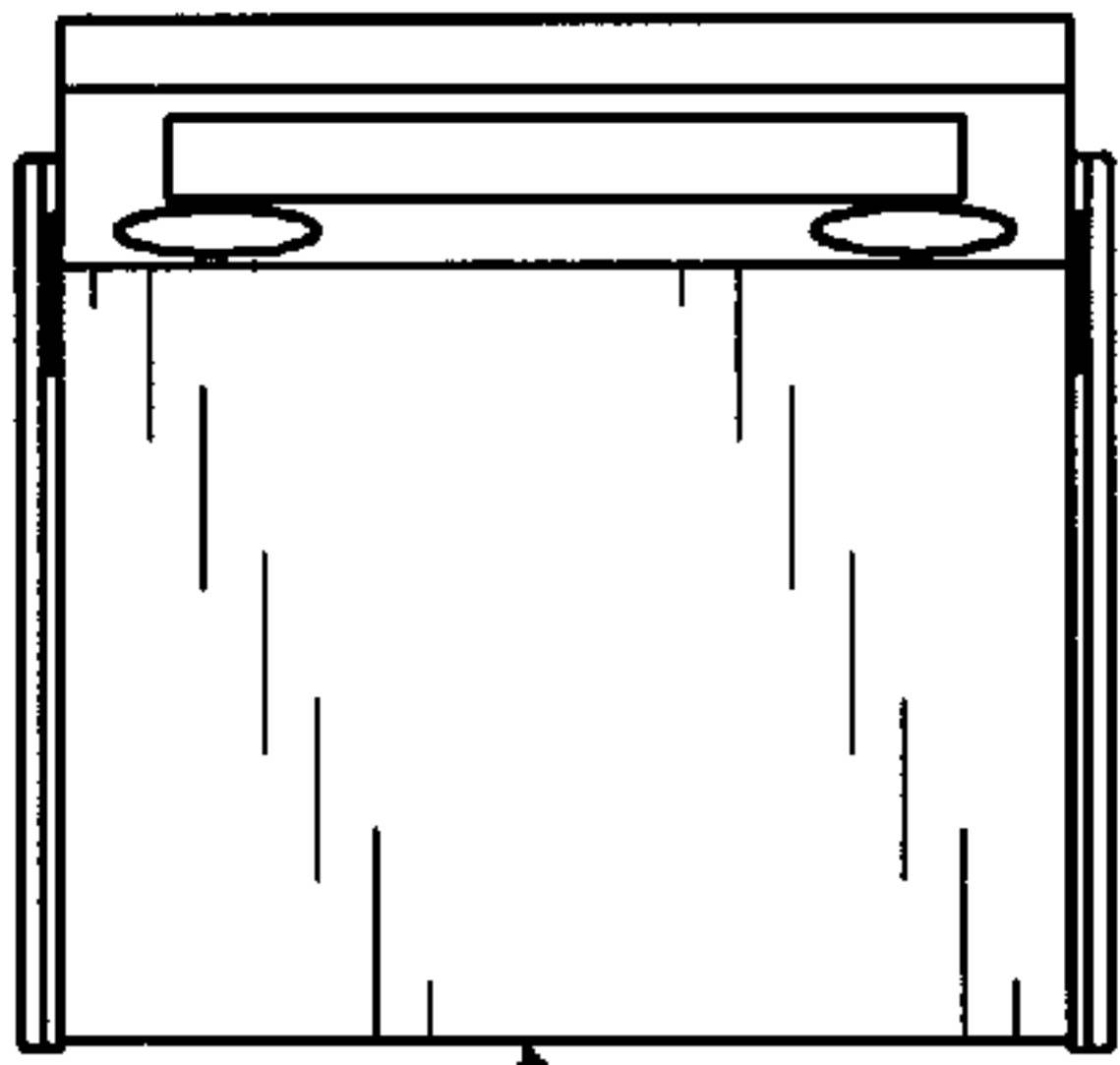

FIG. 47

FIG. 45

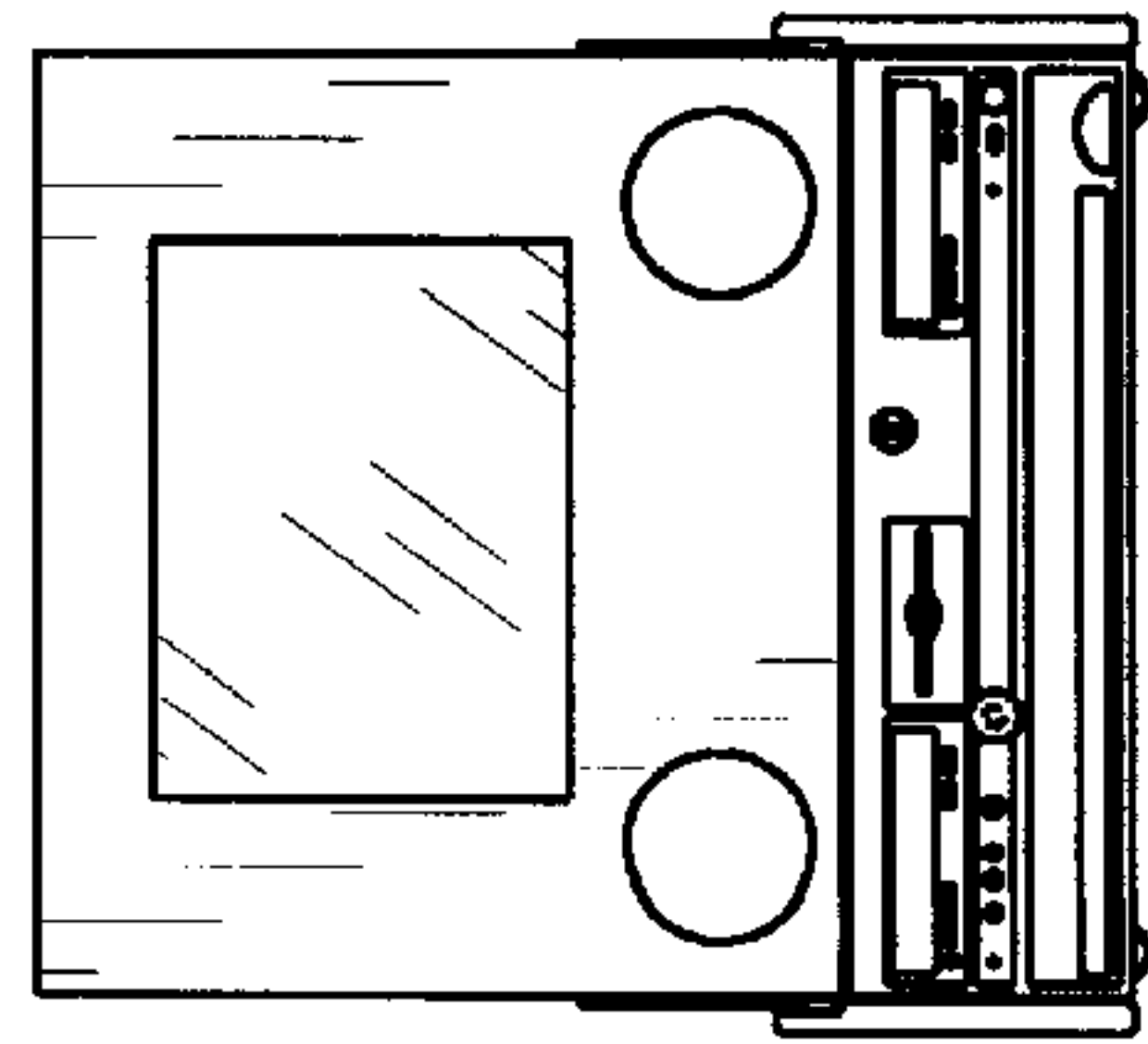
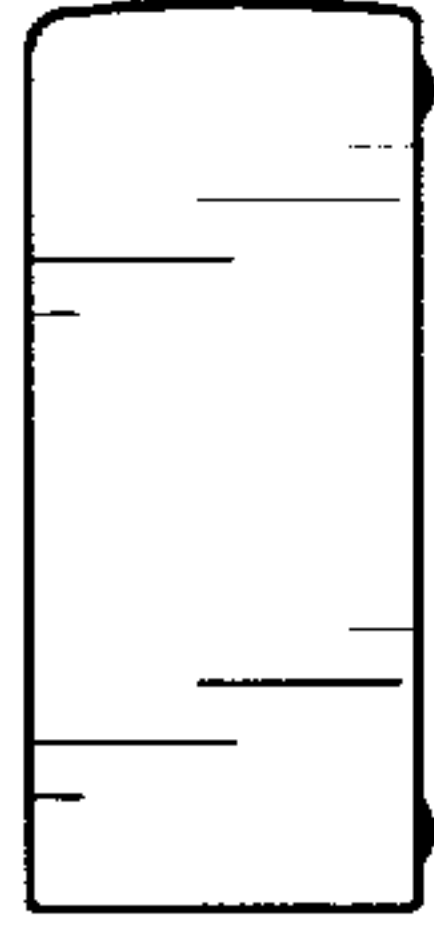

FIG. 41

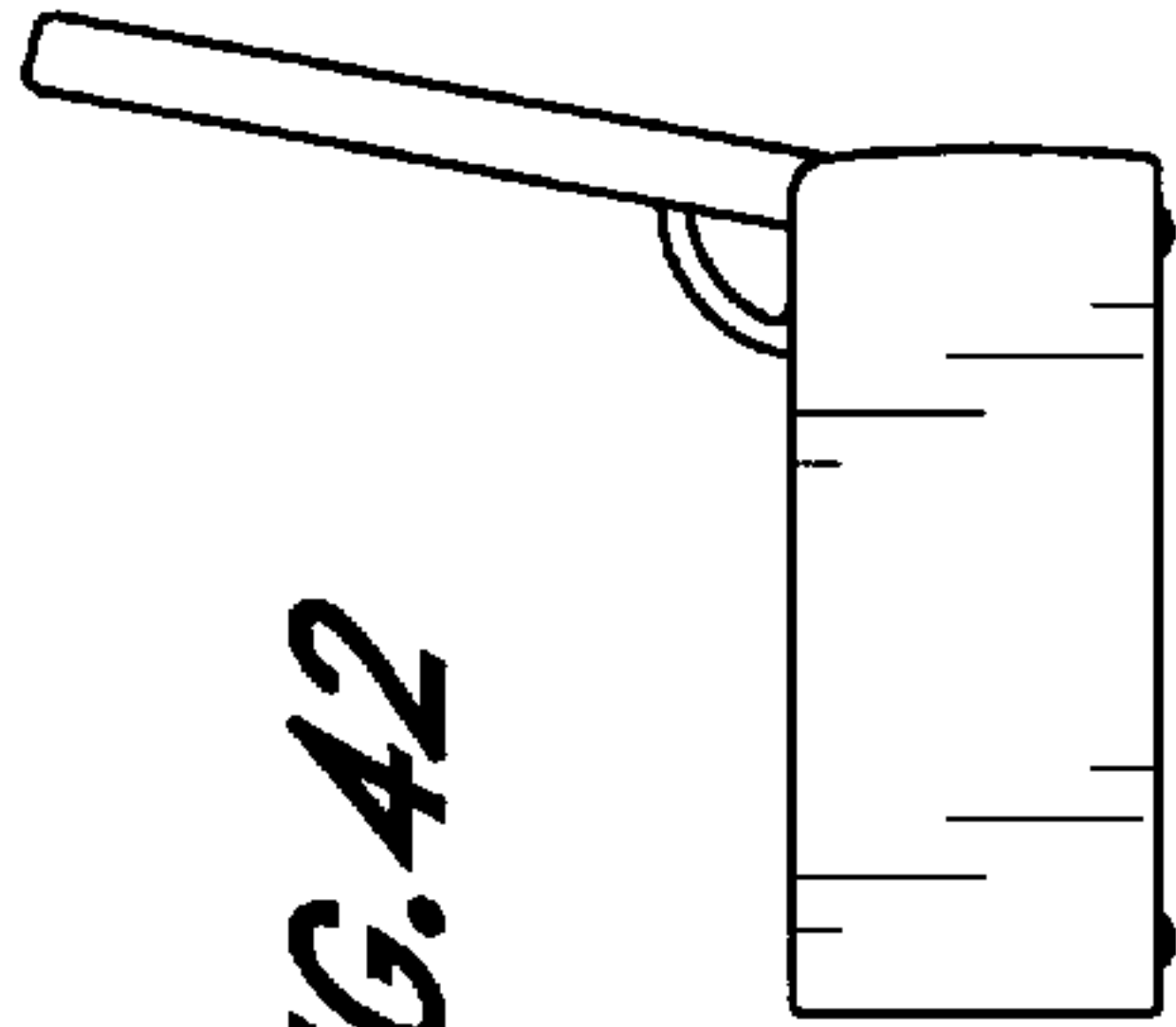

FIG. 42

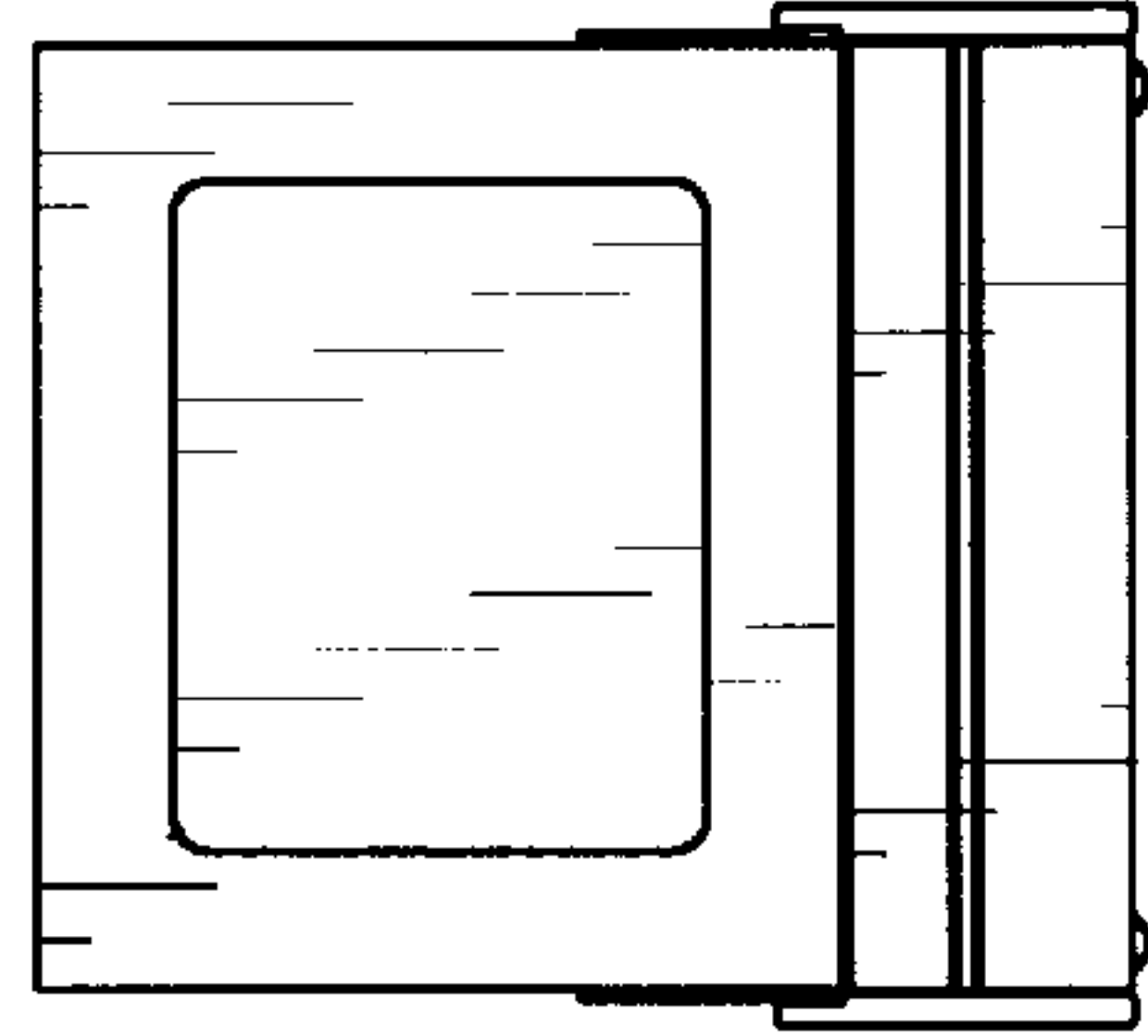

FIG. 46

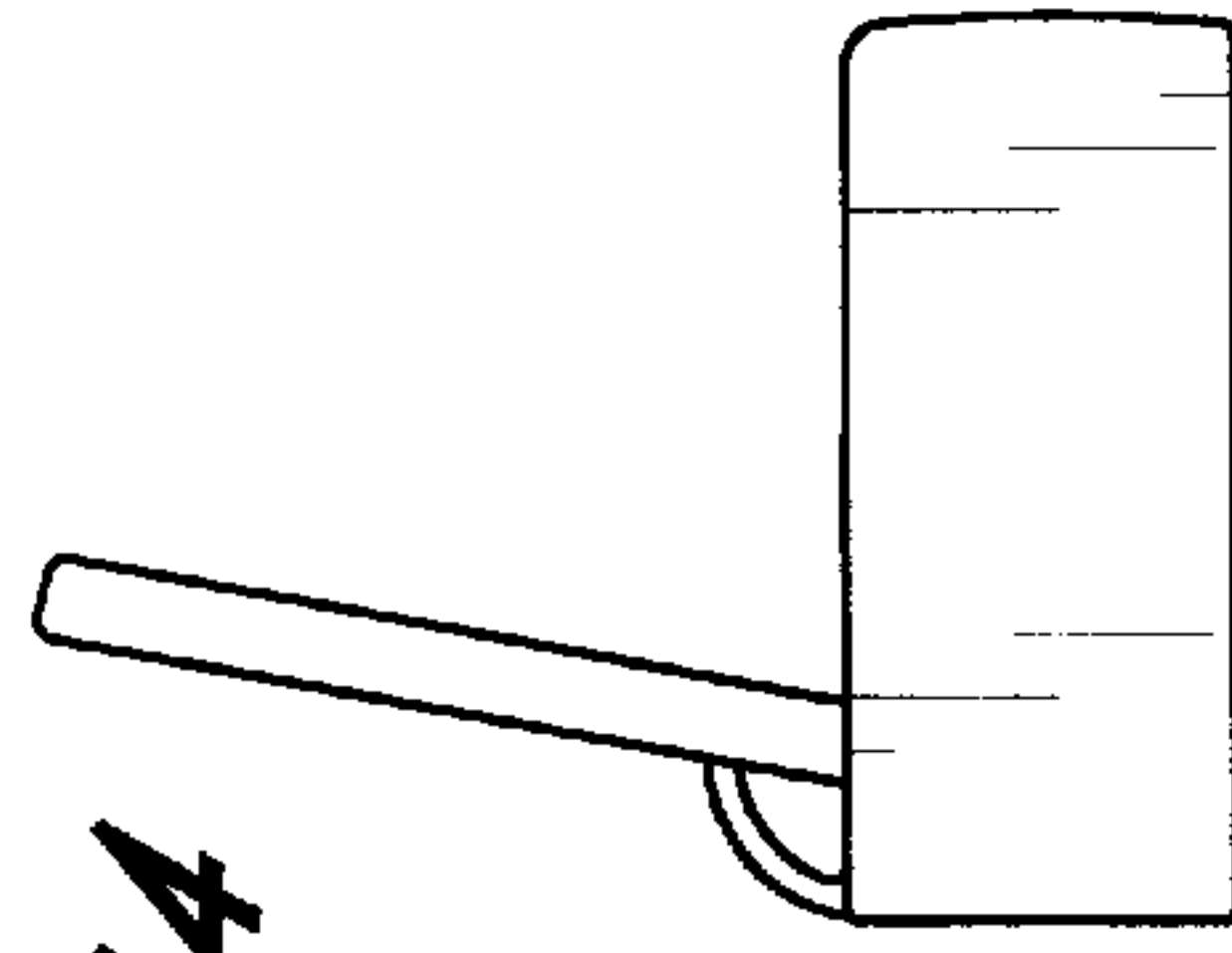

FIG. 44

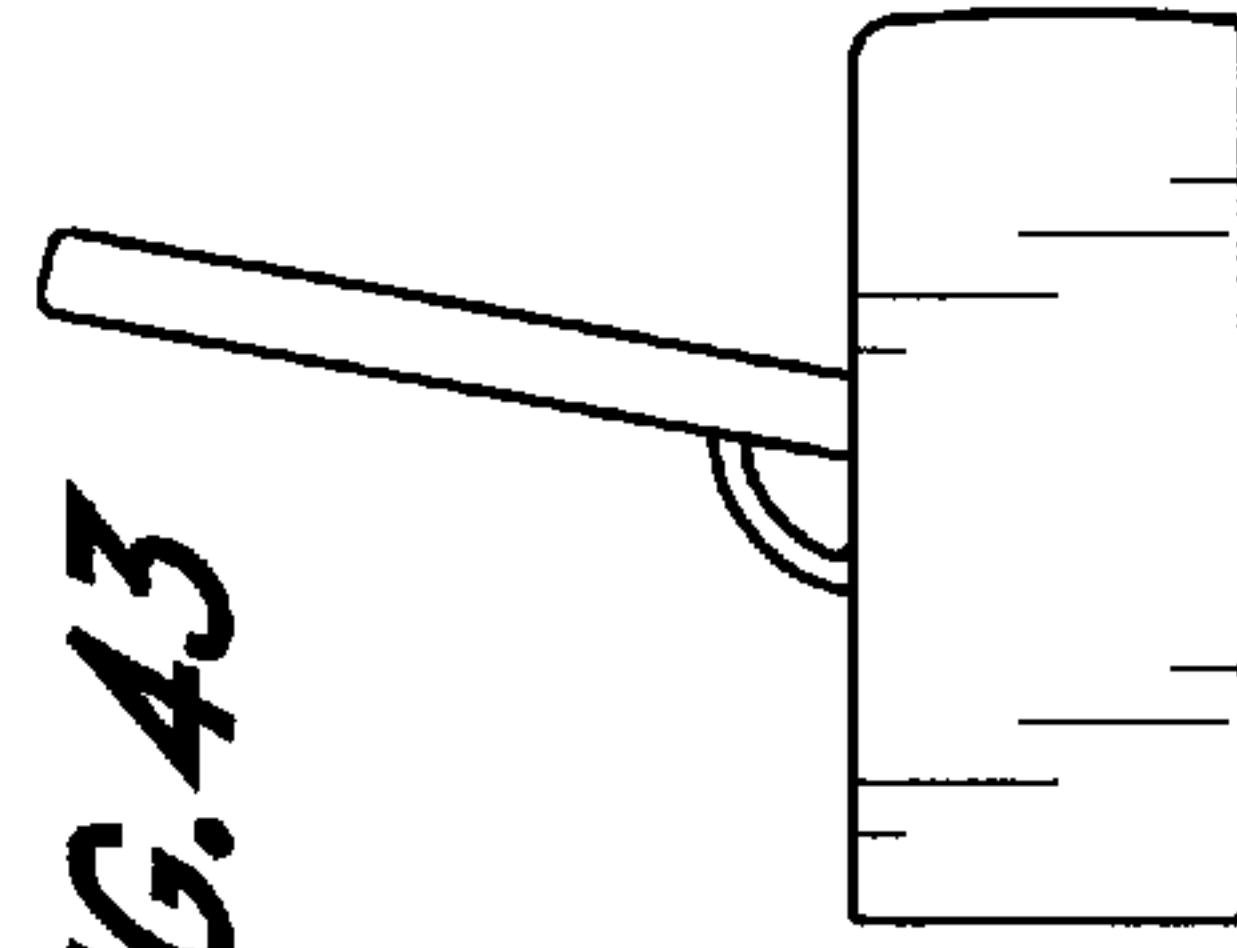

FIG. 43

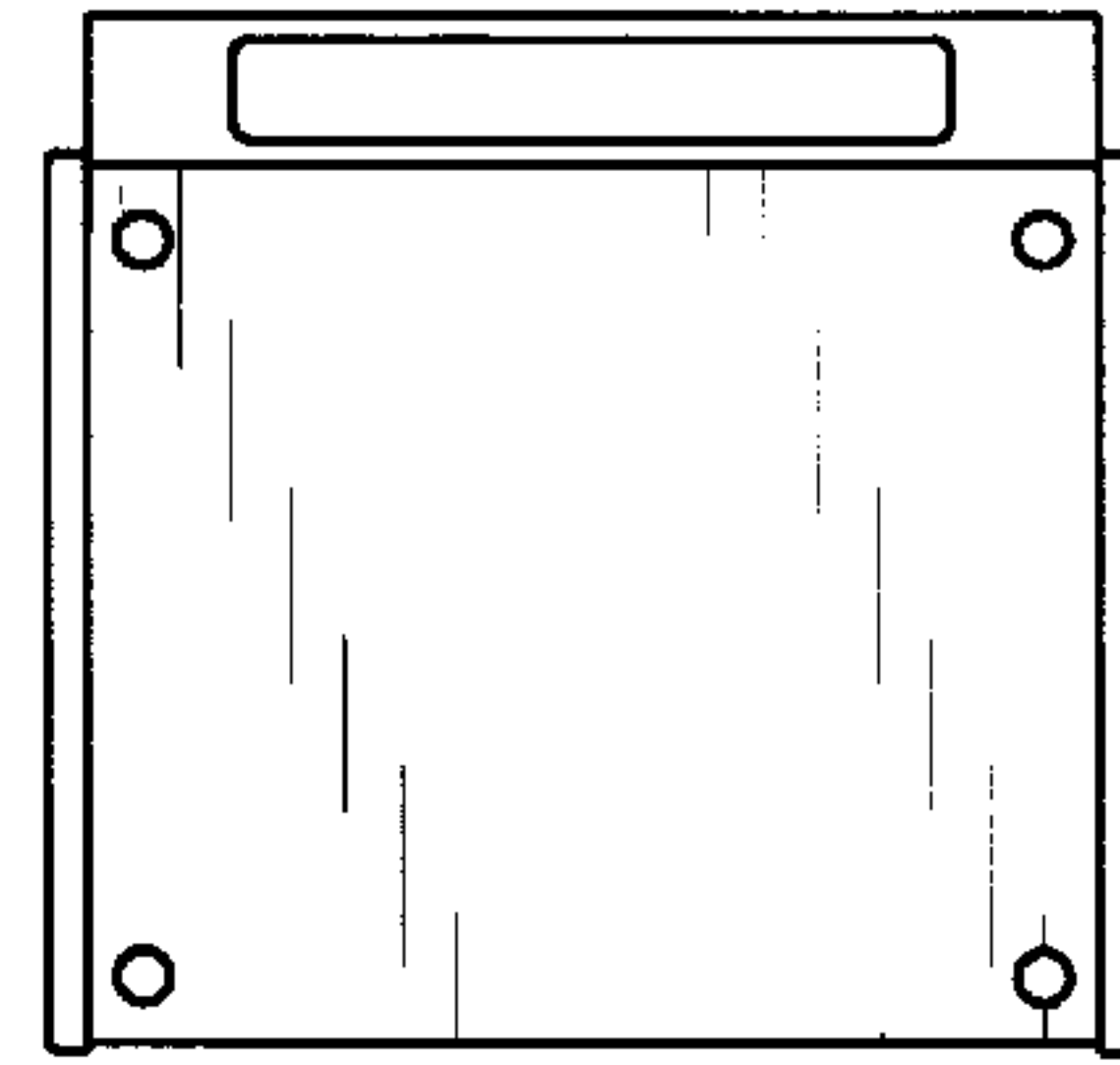

FIG. 48

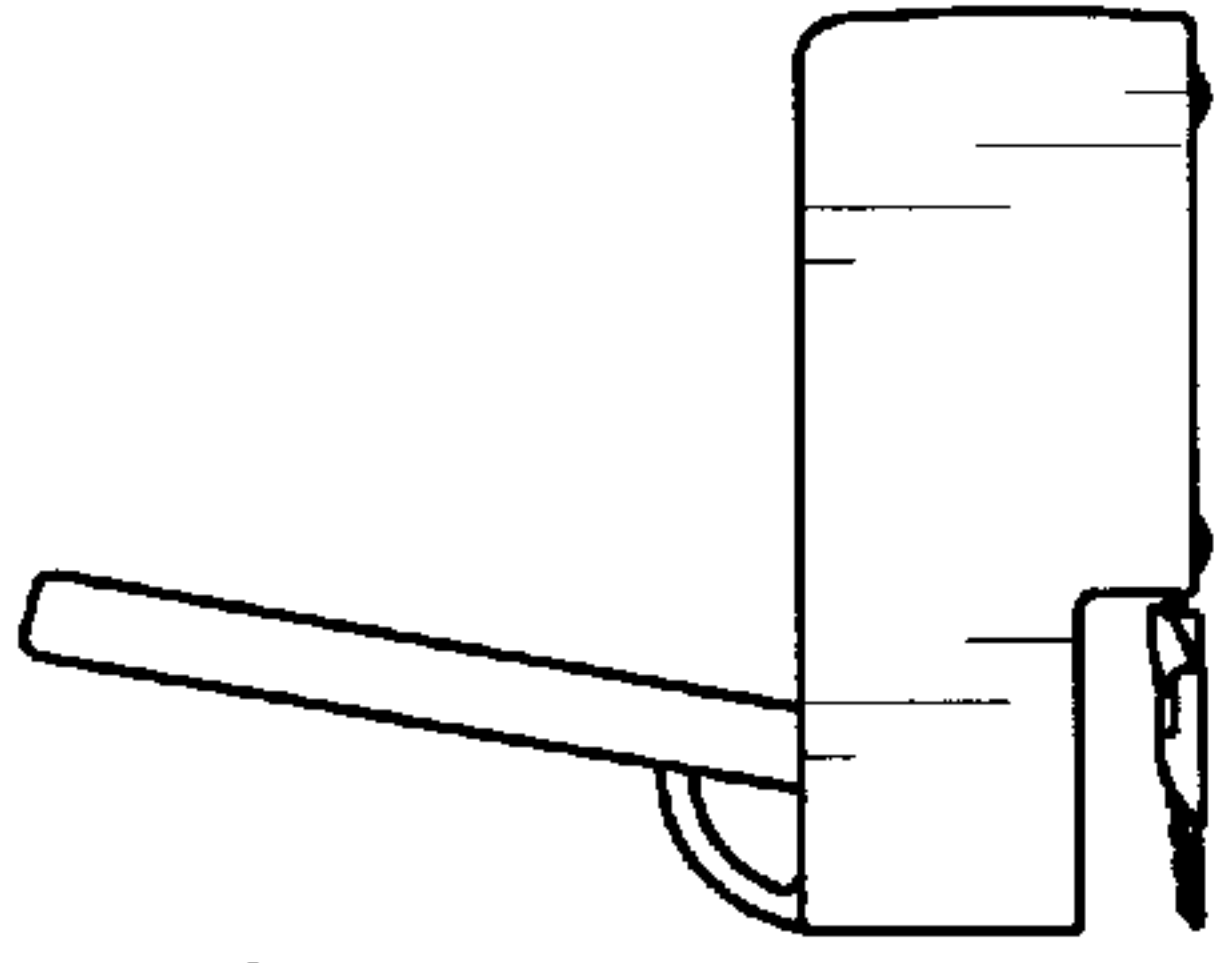

FIG. 51

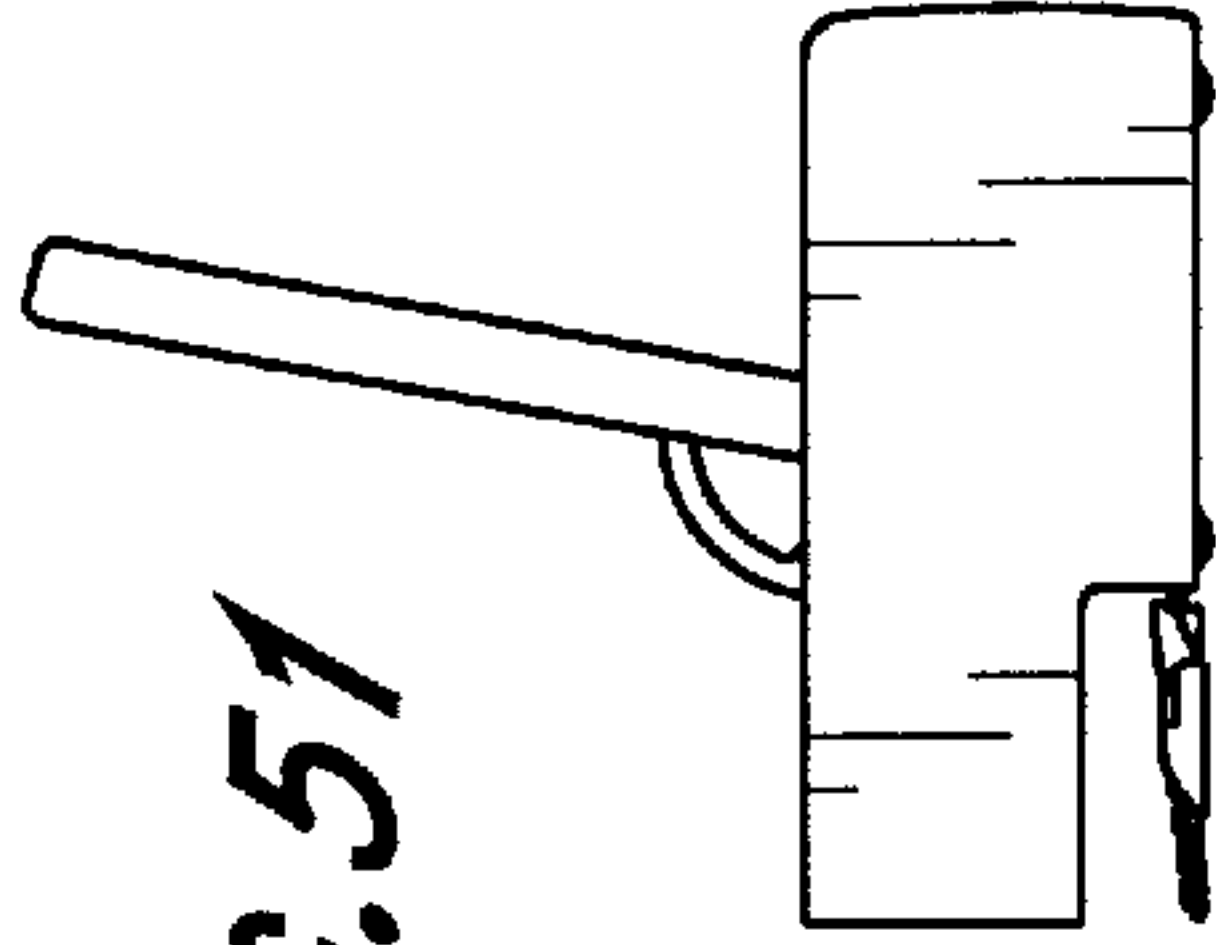

FIG. 52

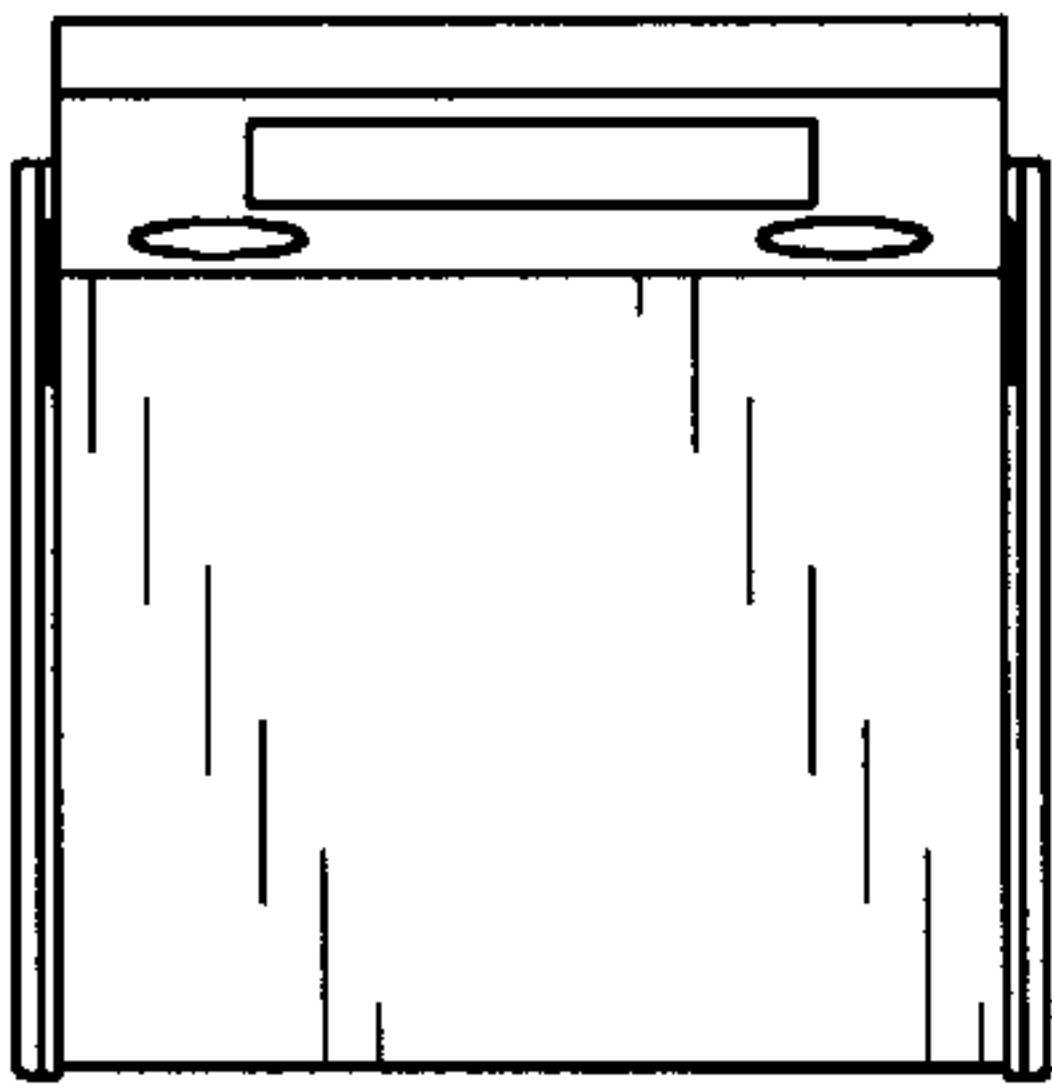

FIG. 53

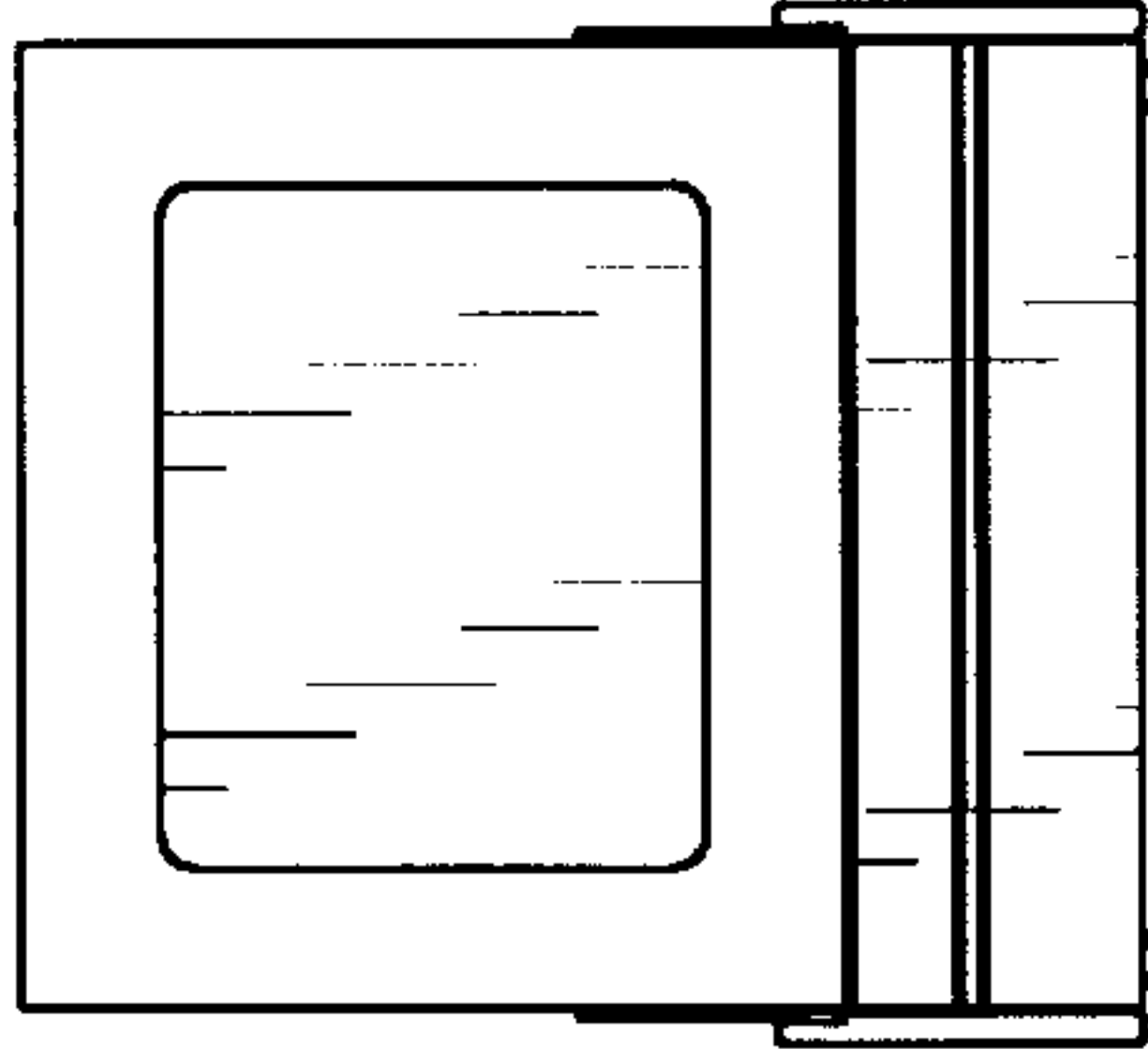

FIG. 49

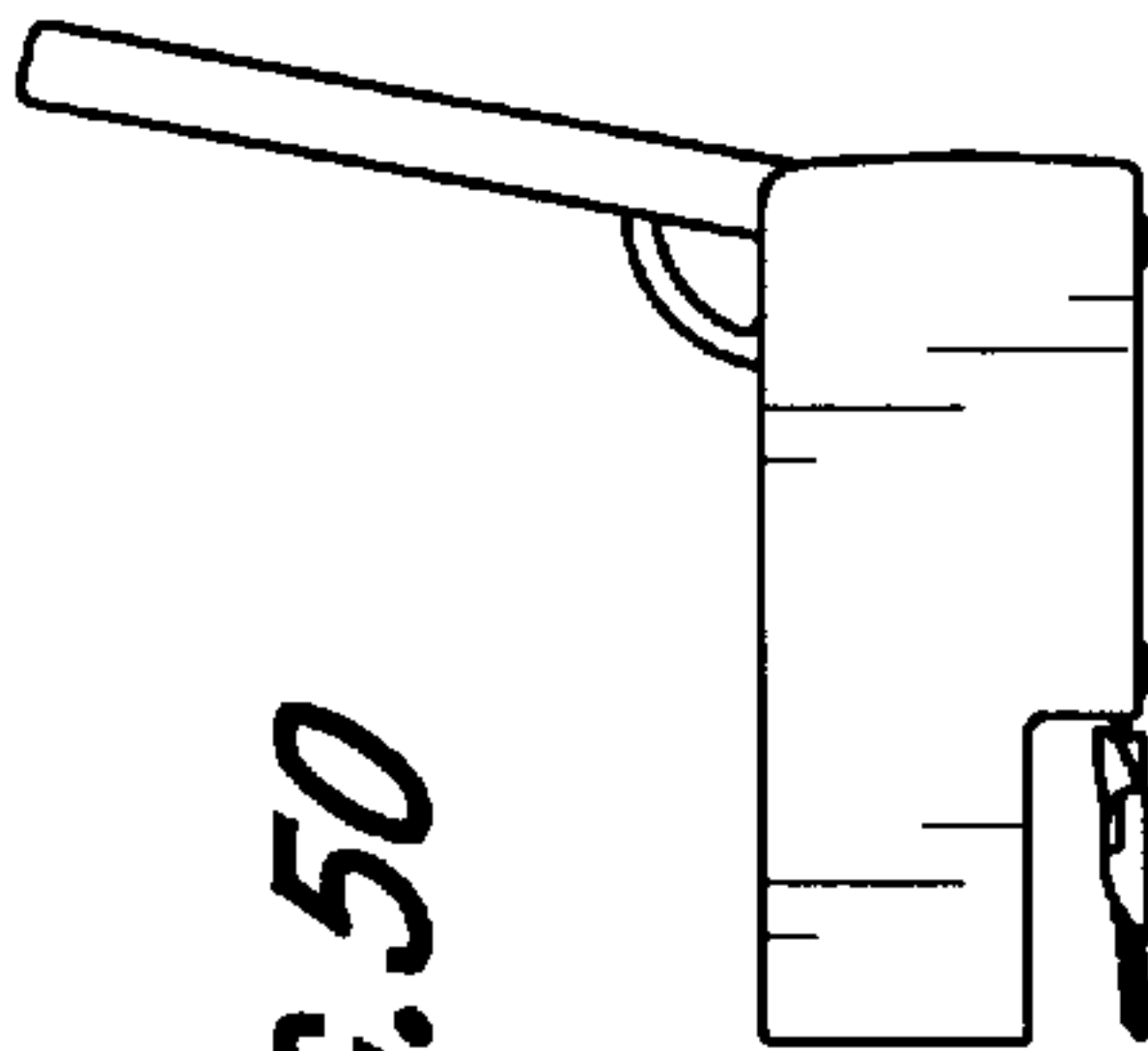

FIG. 50

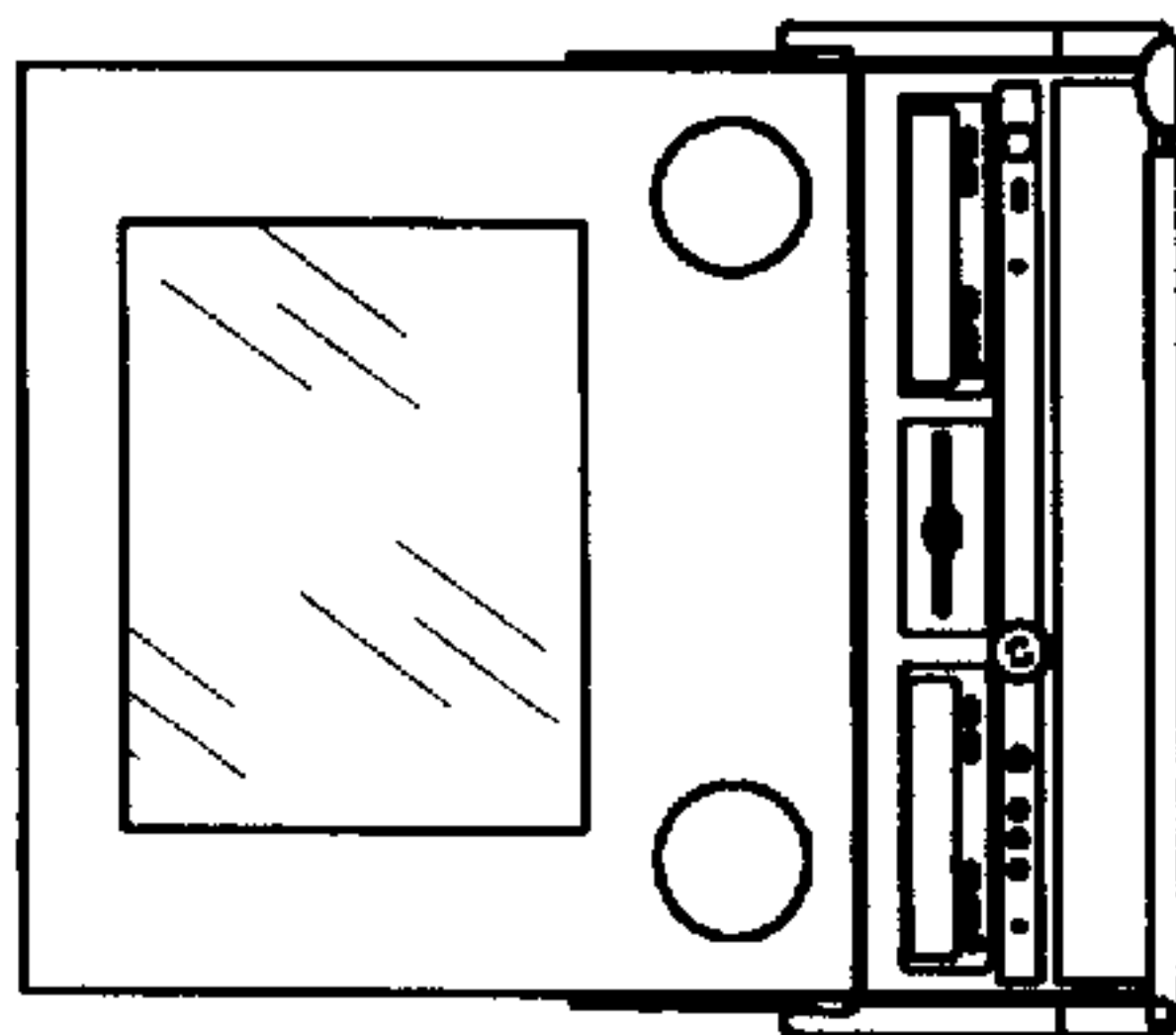

FIG. 54

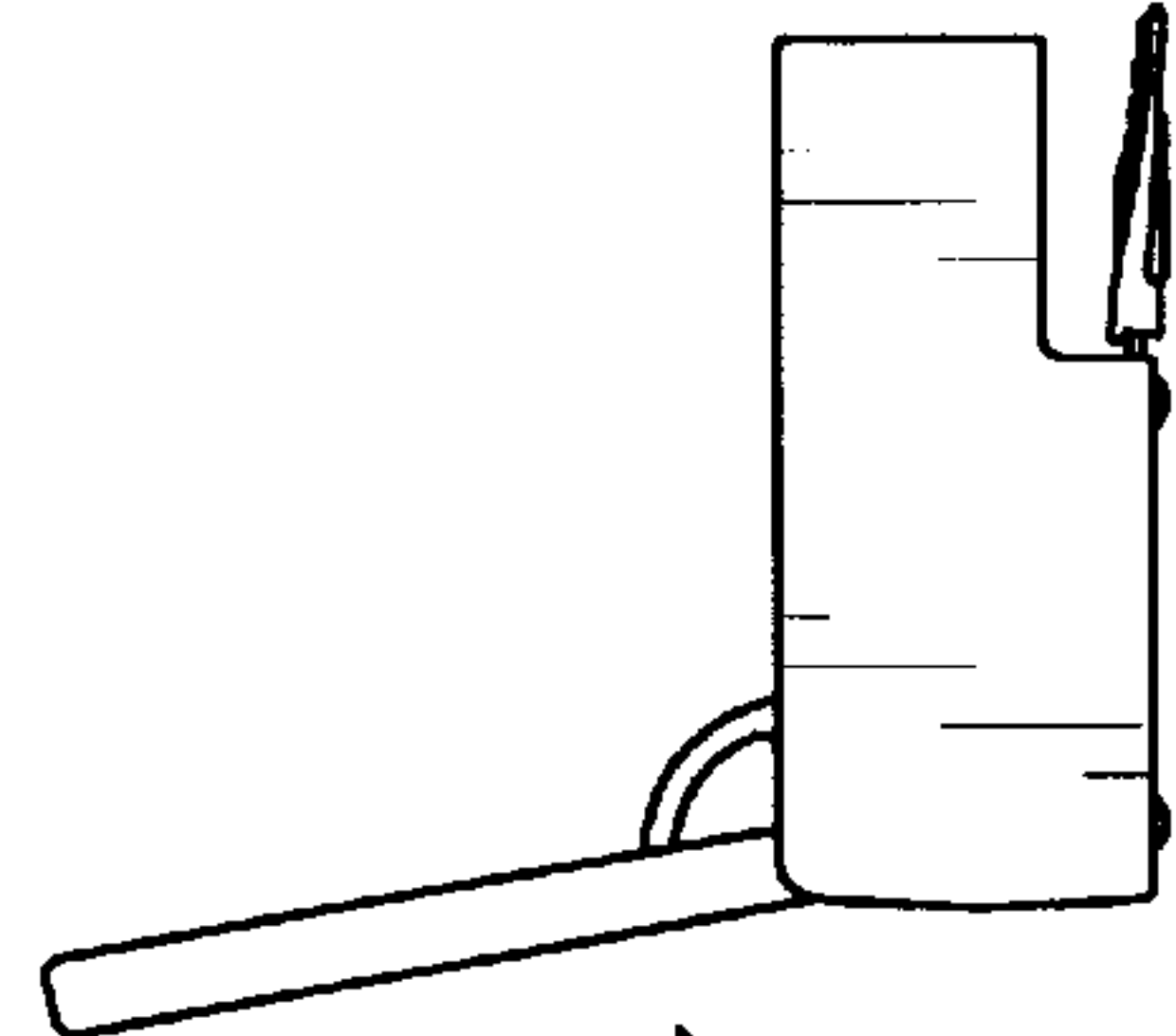

FIG. 55

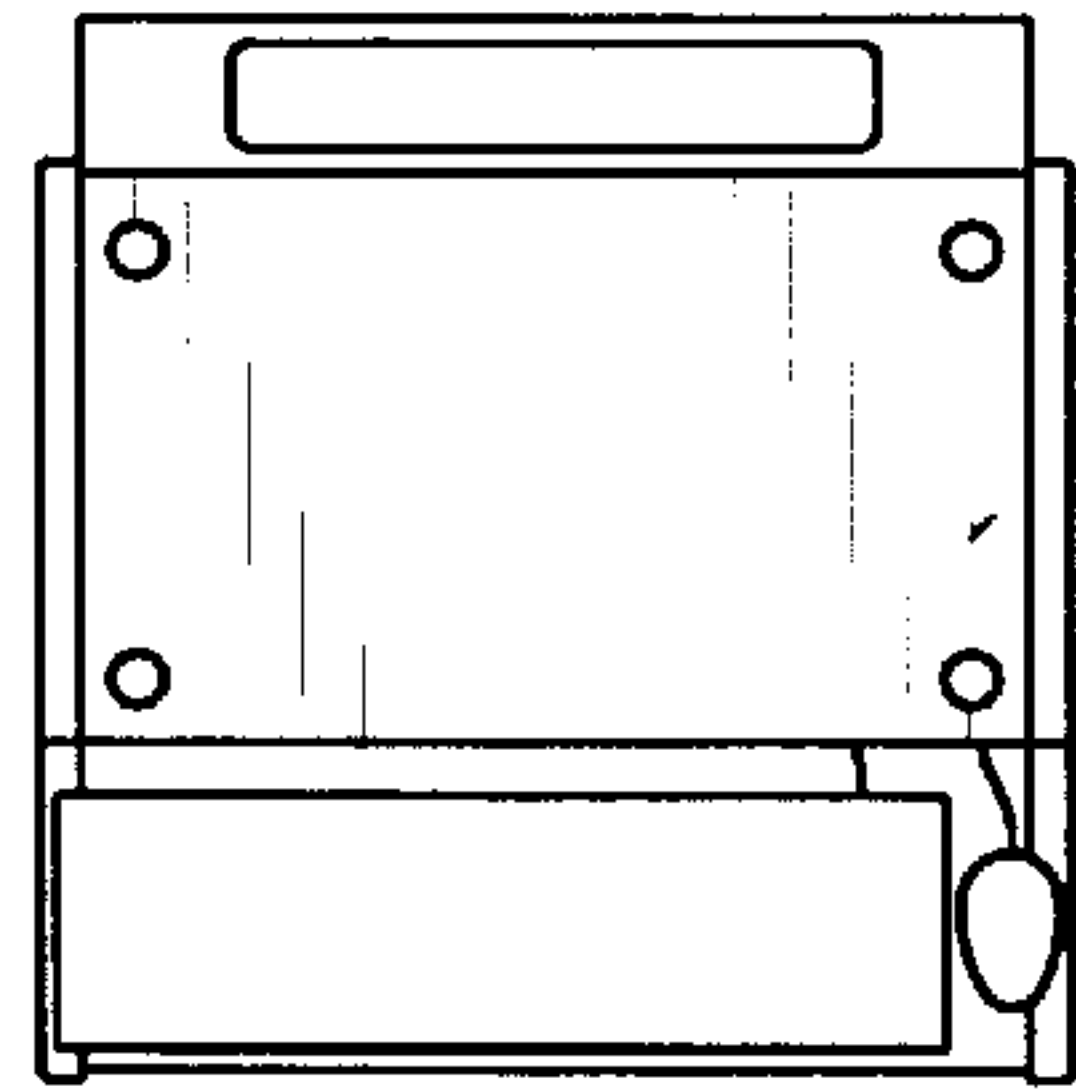

FIG. 56

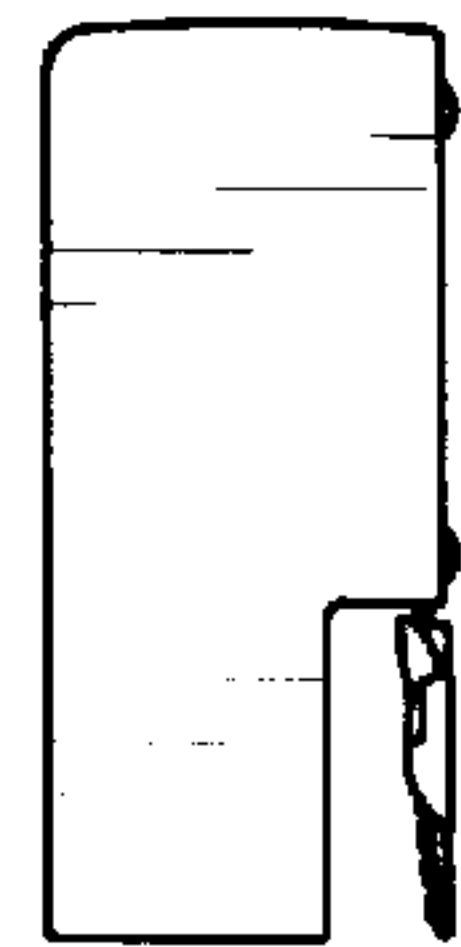

FIG. 57