



US00D427143S

# United States Patent [19] Kulberg

[11] **Patent Number: Des. 427,143**

[45] **Date of Patent: \*\* Jun. 27, 2000**

[54] **BATTERY PACK**

[75] Inventor: **Eric C. Kulberg**, La Jolla, Calif.

[73] Assignee: **QUALCOMM Incorporated**, San Diego, Calif.

[\*\*] Term: **14 Years**

[21] Appl. No.: **29/107,298**

[22] Filed: **Jun. 30, 1999**

[51] **LOC (7) Cl.** ..... **13-02**

[52] **U.S. Cl.** ..... **D13/103**

[58] **Field of Search** ..... D13/103, 119;  
429/96-100, 159, 163, 174

[56] **References Cited**

**U.S. PATENT DOCUMENTS**

- D. 391,622 3/1998 Huynh et al. .... D13/103
- D. 400,161 10/1998 Nagele et al. .... D13/103
- D. 403,655 1/1999 Johansson ..... D13/103
- D. 405,048 2/1999 Mason ..... D13/103

- D. 405,752 2/1999 Mason ..... D13/103
- D. 406,811 3/1999 Richards et al. .... D13/103
- D. 408,008 4/1999 Richards et al. .... D13/103
- 5,935,729 8/1999 Mareno et al. .... 429/100

*Primary Examiner*—Joel Sincavage  
*Attorney, Agent, or Firm*—Gregory D. Ograd

[57] **CLAIM**

We claim the ornamental design for a battery pack, as shown.

**DESCRIPTION**

FIG. 1 is a top perspective view of the battery pack;  
FIG. 2 is a top plan view thereof;  
FIG. 3 is a front plan view thereof;  
FIG. 4 is a rear view thereof;  
FIG. 5 is a side plan view thereof;  
FIG. 6 is an opposite side plan view thereof from FIG. 5;  
and,  
FIG. 7 is a bottom plan view thereof.

**1 Claim, 2 Drawing Sheets**

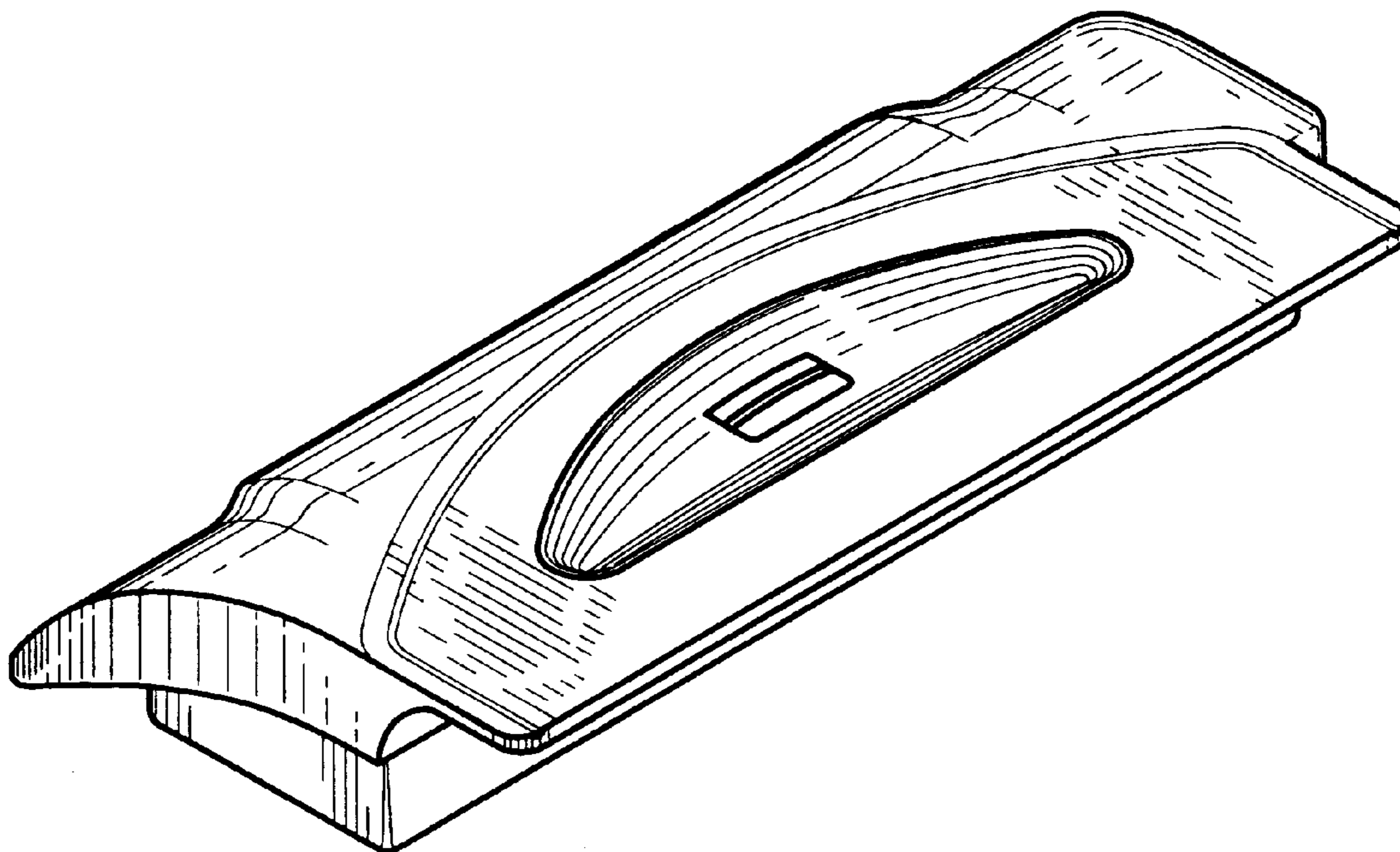

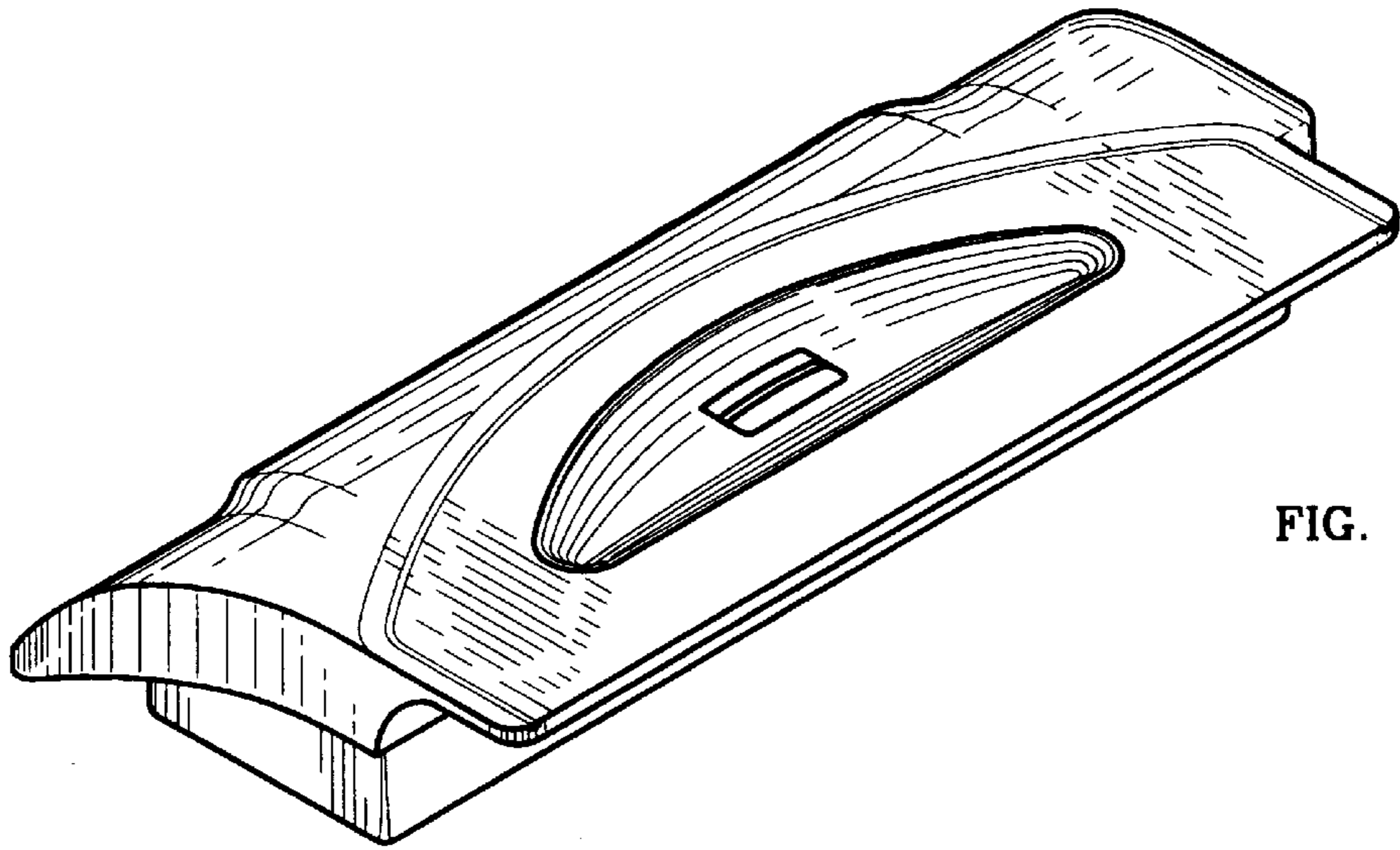

FIG. 1

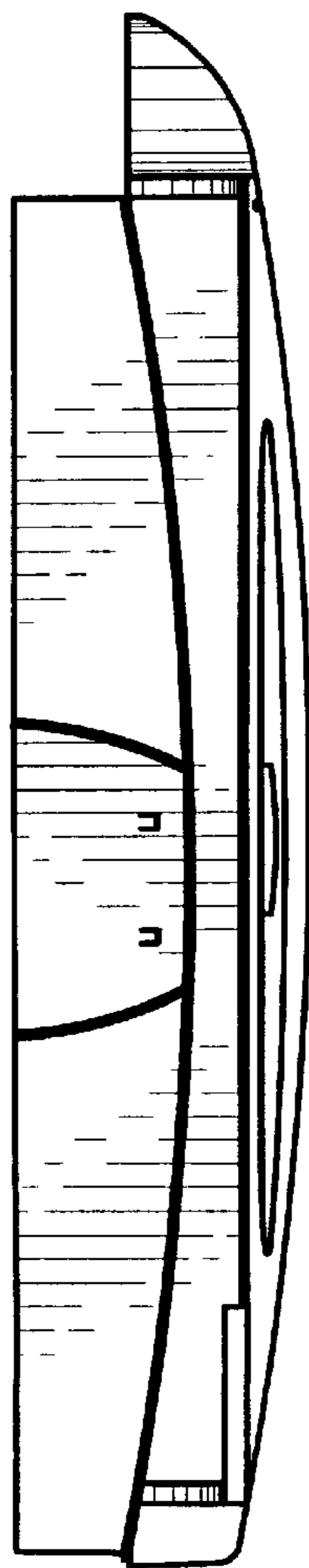

FIG. 3

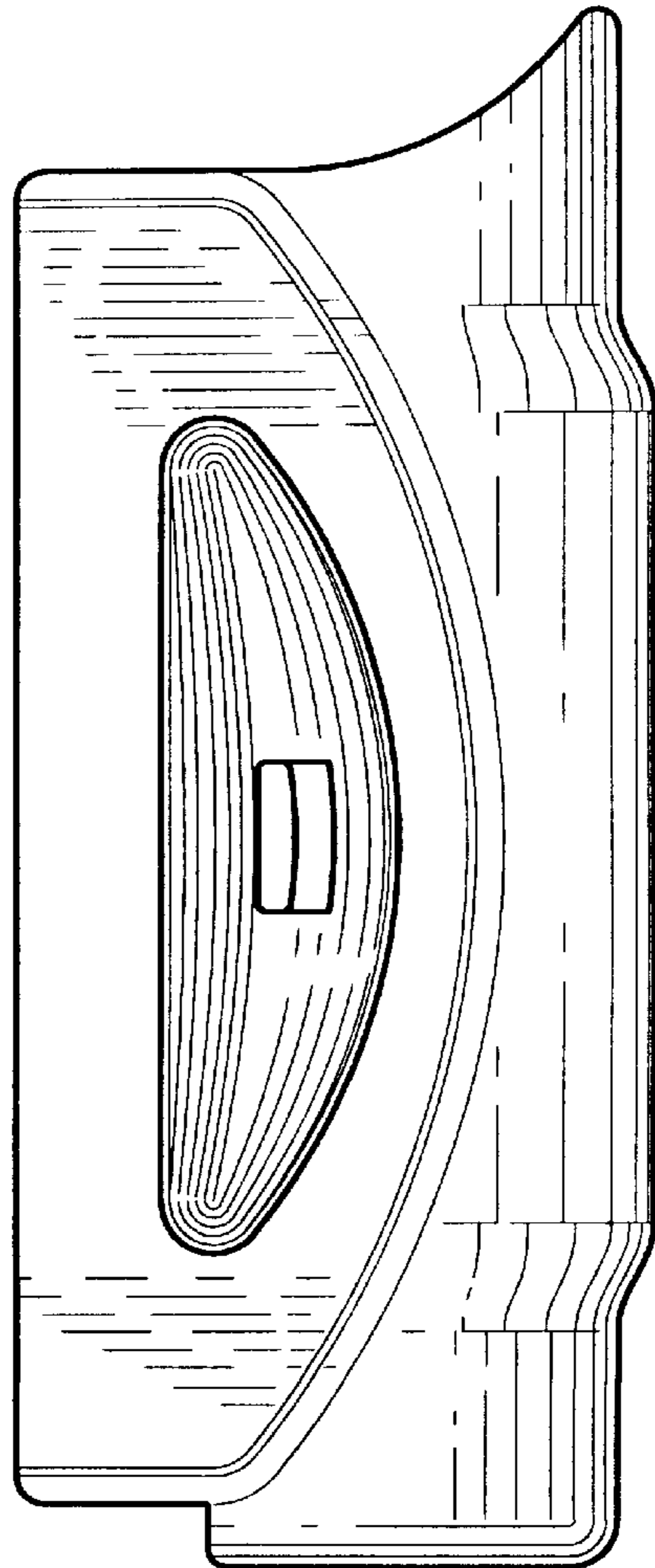

FIG. 2

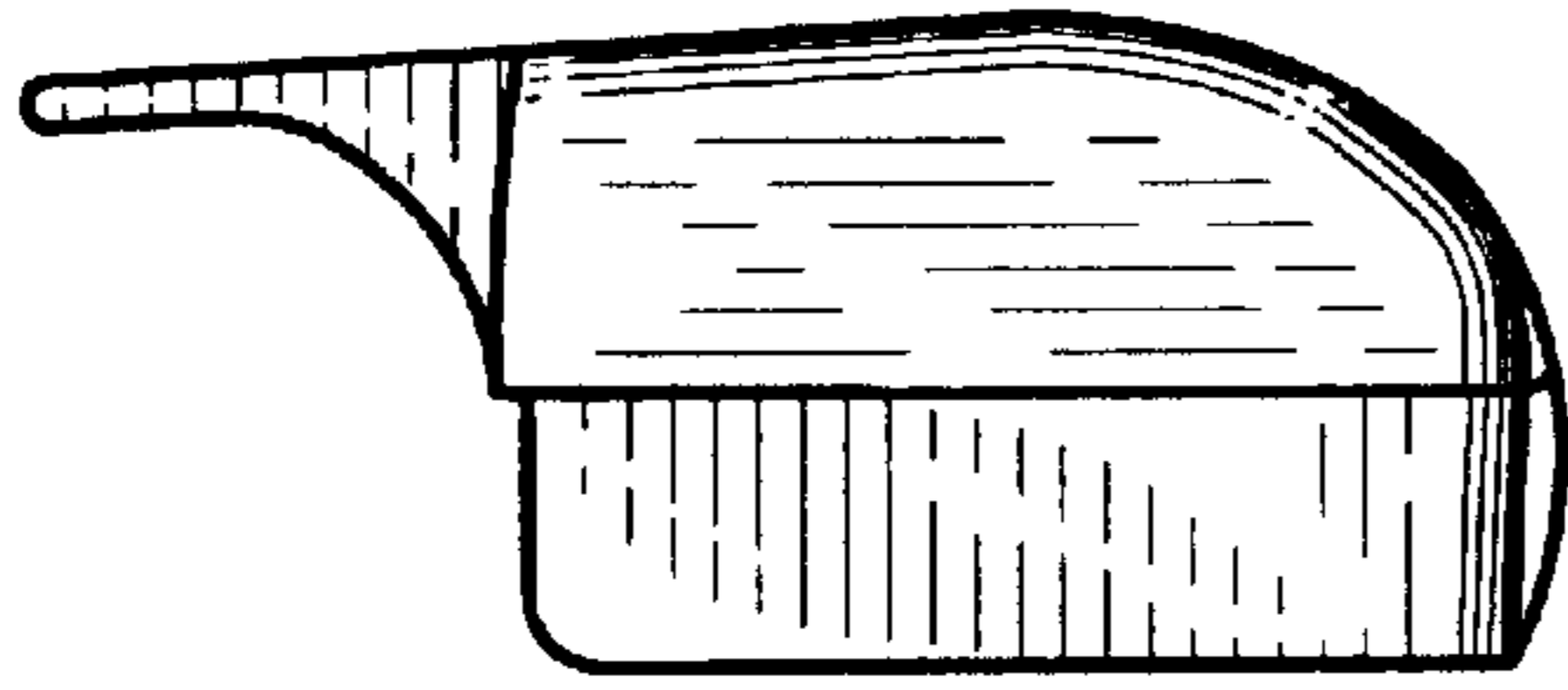

FIG. 5

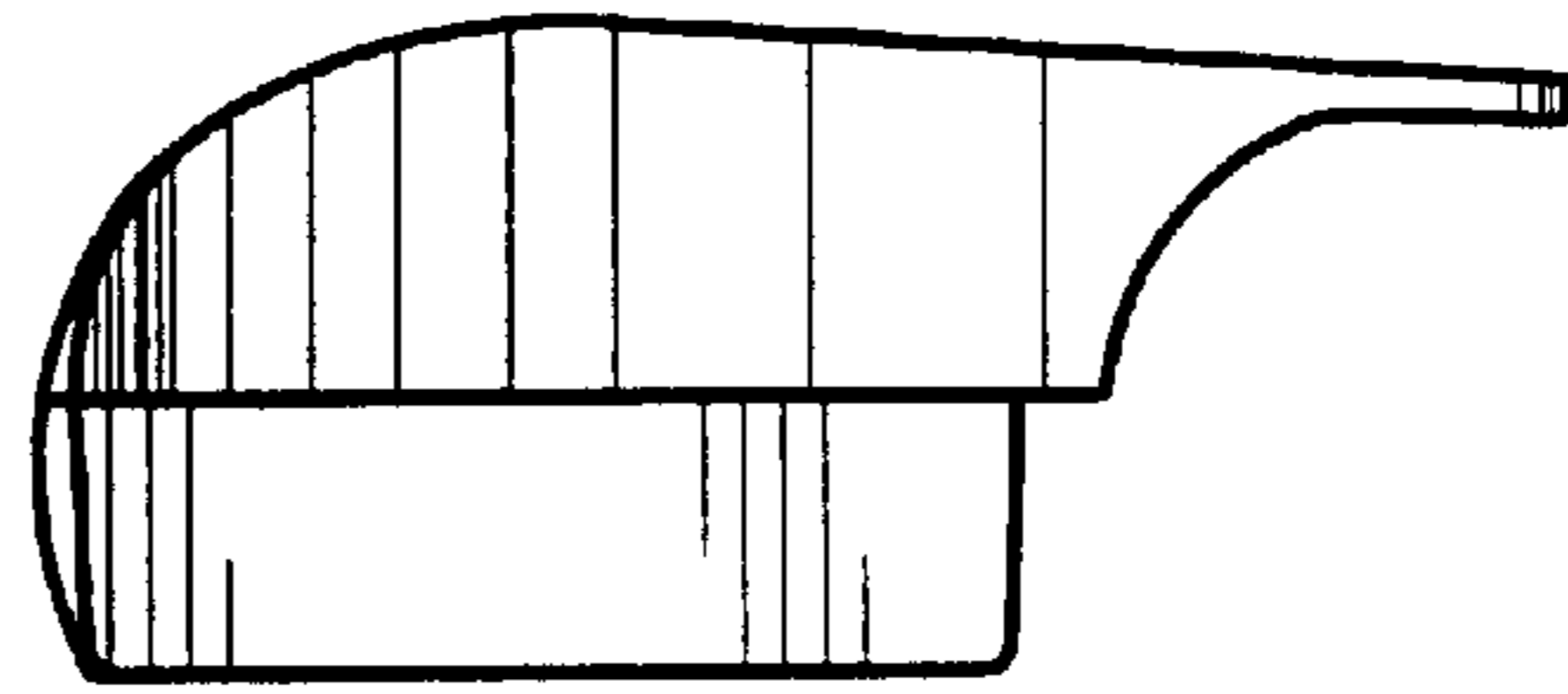

FIG. 6

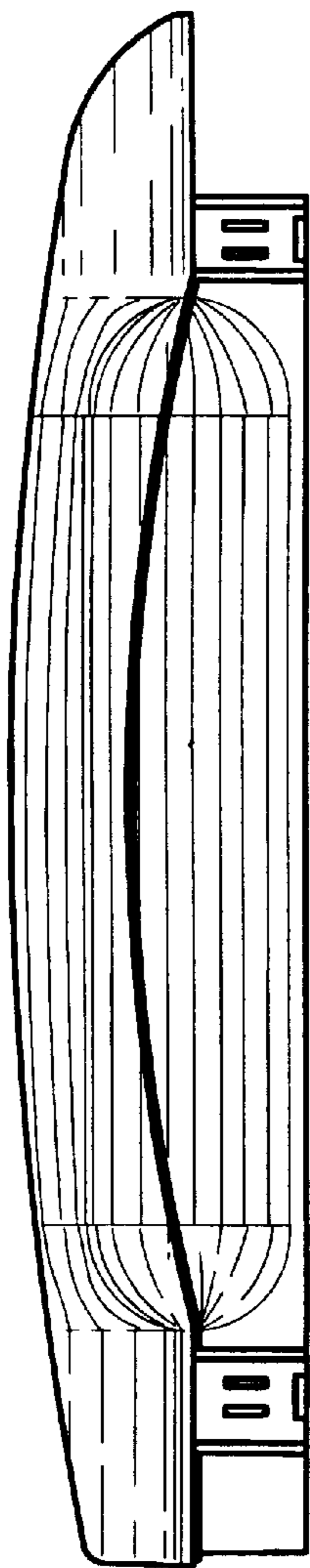

FIG. 4

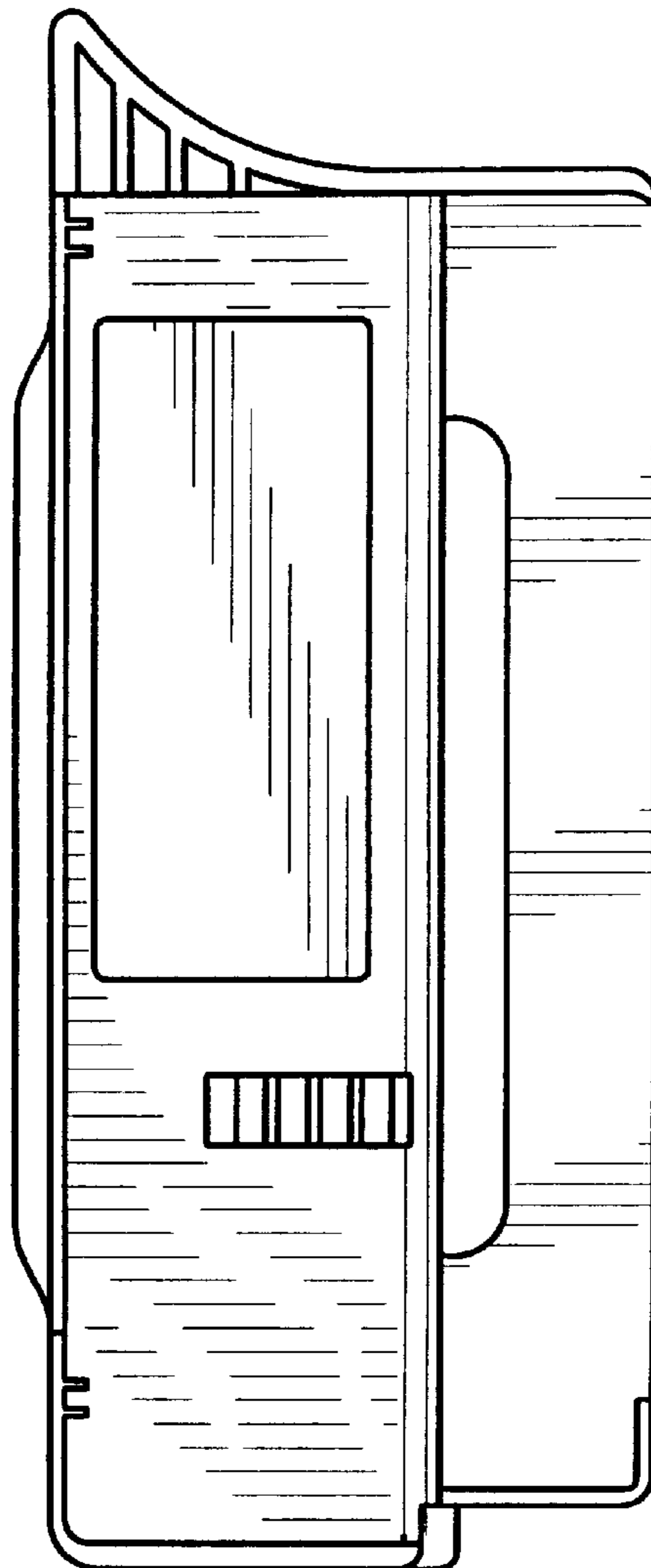

FIG. 7