



US00D427137S

# United States Patent [19]

Lee et al.

[11] **Patent Number: Des. 427,137**

[45] **Date of Patent: \*\* Jun. 27, 2000**

[54] **AIRSHIP**

[75] Inventors: **Yee-Chun Lee**, Cabin John, Md.; **Elena A. Novakovskaia**, Springfield, Va.

[73] Assignee: **Sky Station International, Inc.**, Washington, D.C.

[\*\*] Term: **14 Years**

[21] Appl. No.: **29/085,575**

[22] Filed: **Mar. 26, 1998**

[51] **LOC (7) Cl.** ..... **12-07**

[52] **U.S. Cl.** ..... **D12/319; D12/339**

[58] **Field of Search** ..... **D12/319-345; 244/29, 30, 24, 97, 125, 128, 129, 130**

[56] **References Cited**

**U.S. PATENT DOCUMENTS**

D. 166,475	4/1952	Lewis	.....	D12/323
5,071,090	12/1991	Takahashi et al.	.....	244/29
5,285,986	2/1994	Hagenlocher	.....	244/97

*Primary Examiner*—Kay H. Chin  
*Attorney, Agent, or Firm*—Breneman & Georges

[57] **CLAIM**

The ornamental design for an airship, as shown and described.

**DESCRIPTION**

FIG. 1 is a front perspective view of an airship showing our new design;  
FIG. 2 is a rear perspective view thereof;  
FIG. 3 is a right side elevational view thereof;  
FIG. 4 is a left side elevational view thereof;  
FIG. 5 is a top plan view thereof;  
FIG. 6 is a bottom plan view thereof;  
FIG. 7 is a front elevational view thereof;  
FIG. 8 is a rear elevational view thereof;  
FIG. 9 is a front perspective view of a second embodiment of the airship; and,  
FIG. 10 is a rear perspective view of FIG. 9.  
The broken lines shown in the views are understood to represent stitching.

**1 Claim, 5 Drawing Sheets**

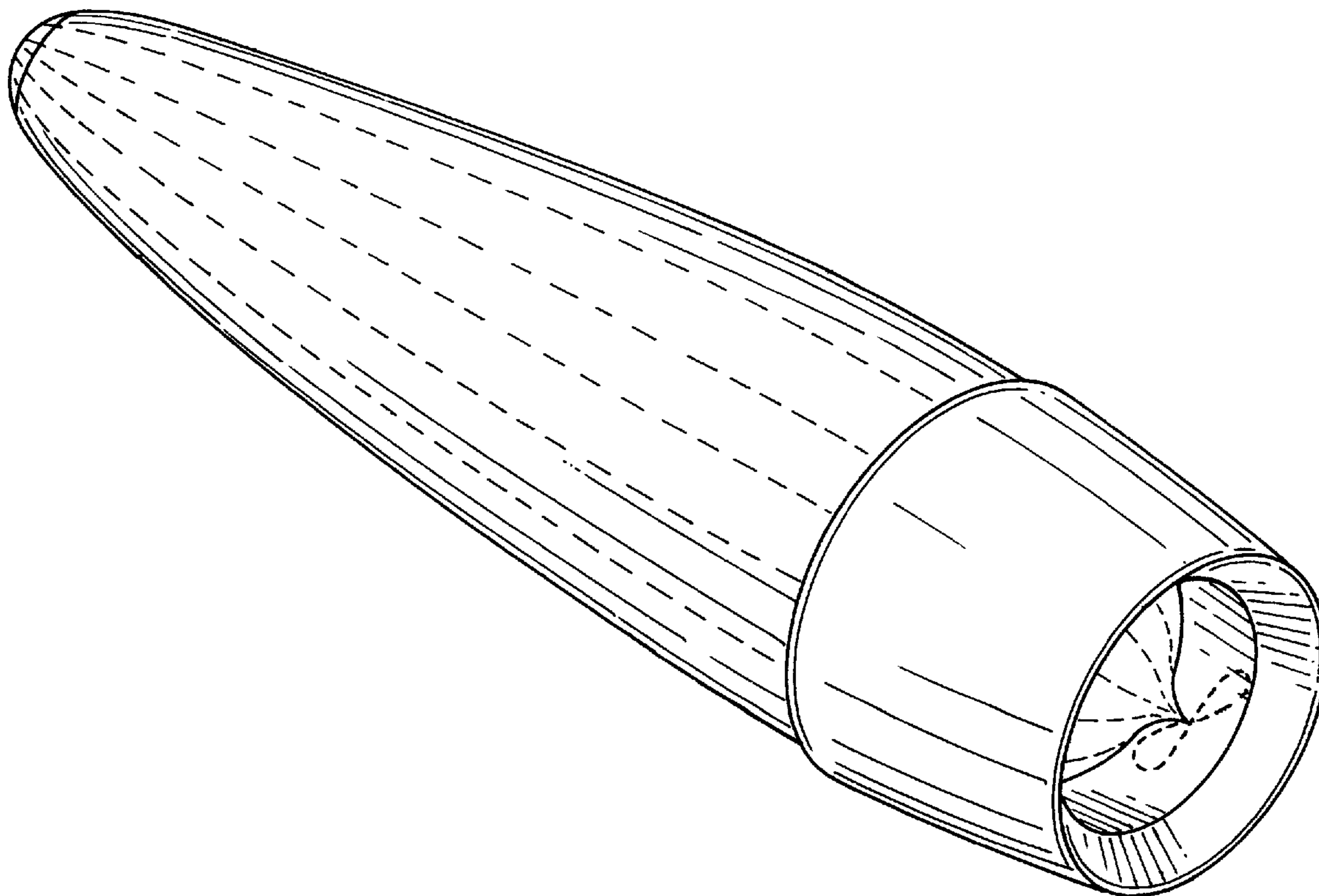

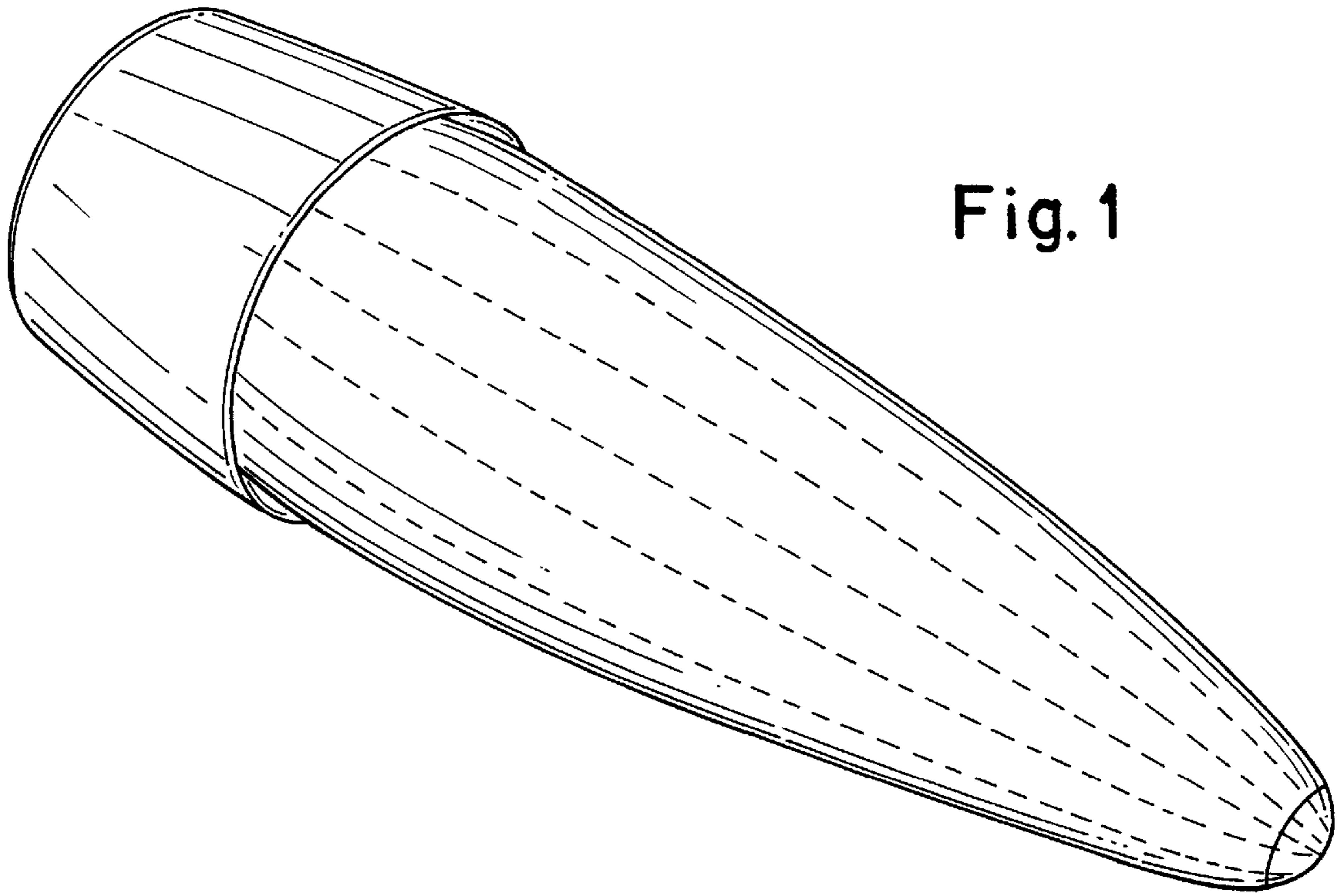

Fig. 1

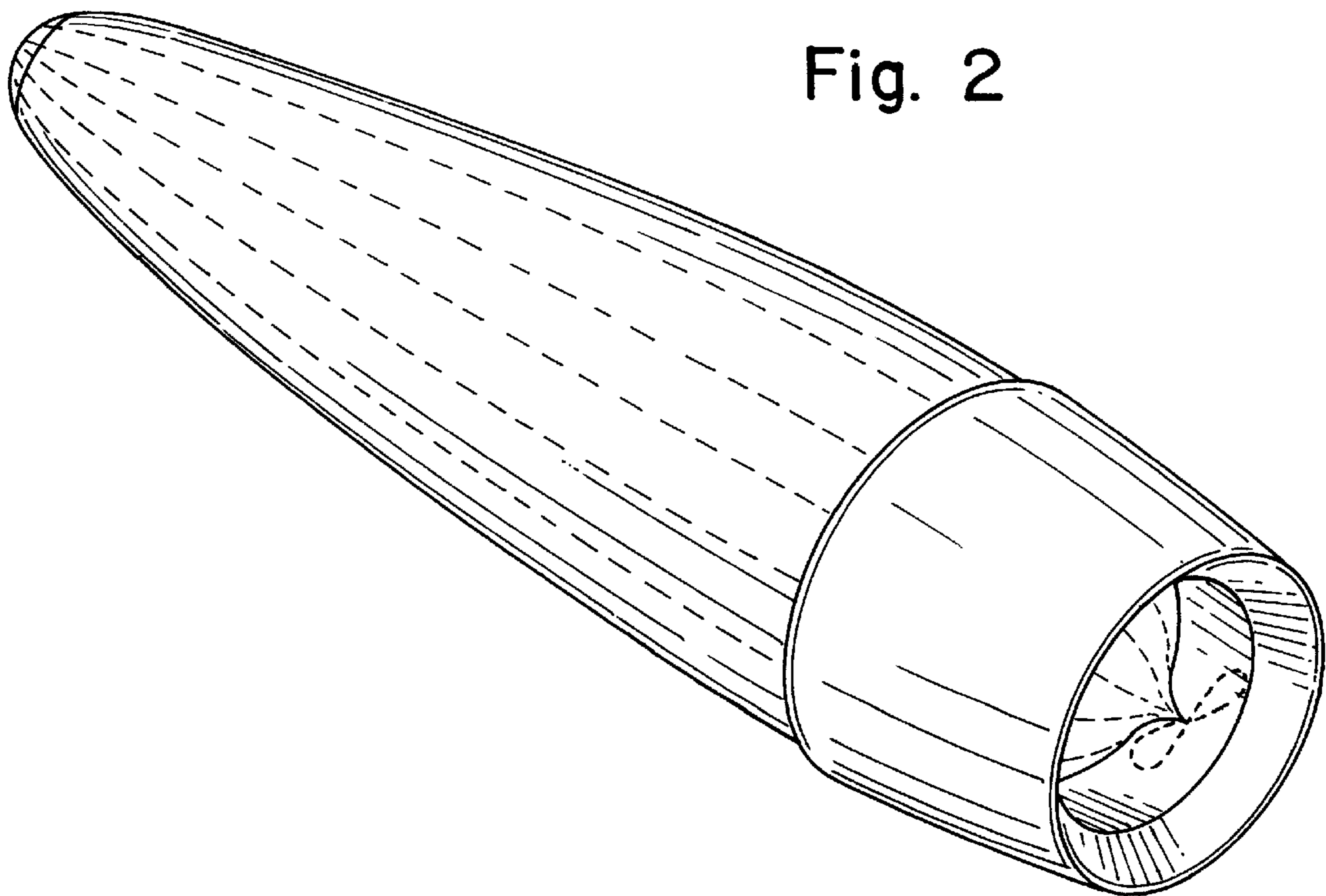

Fig. 2

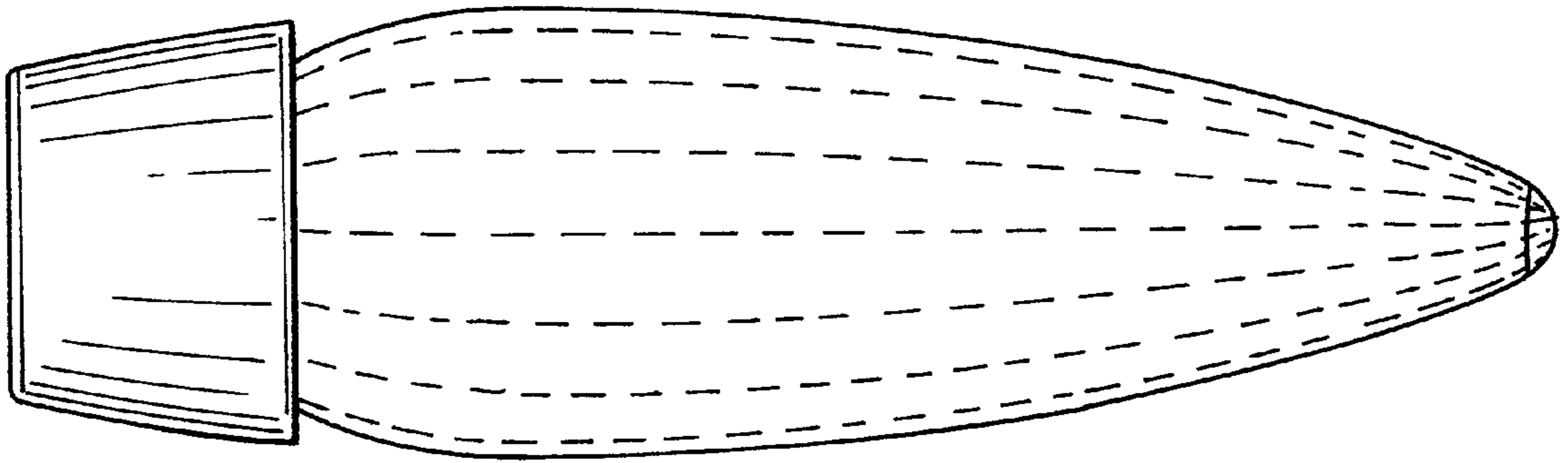

Fig. 3

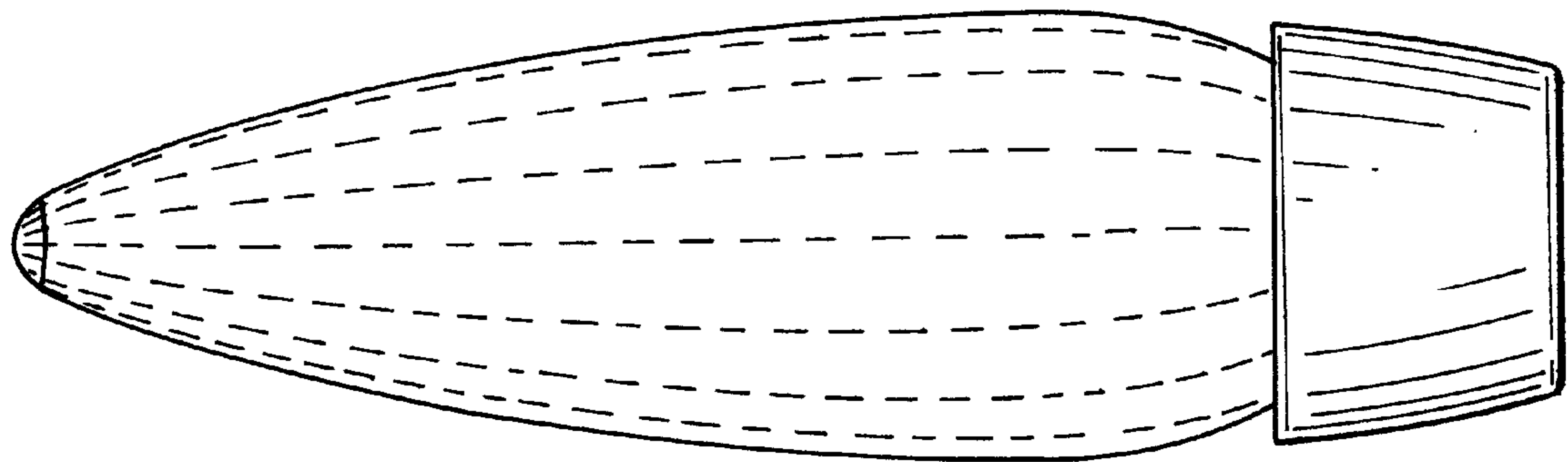

Fig. 4

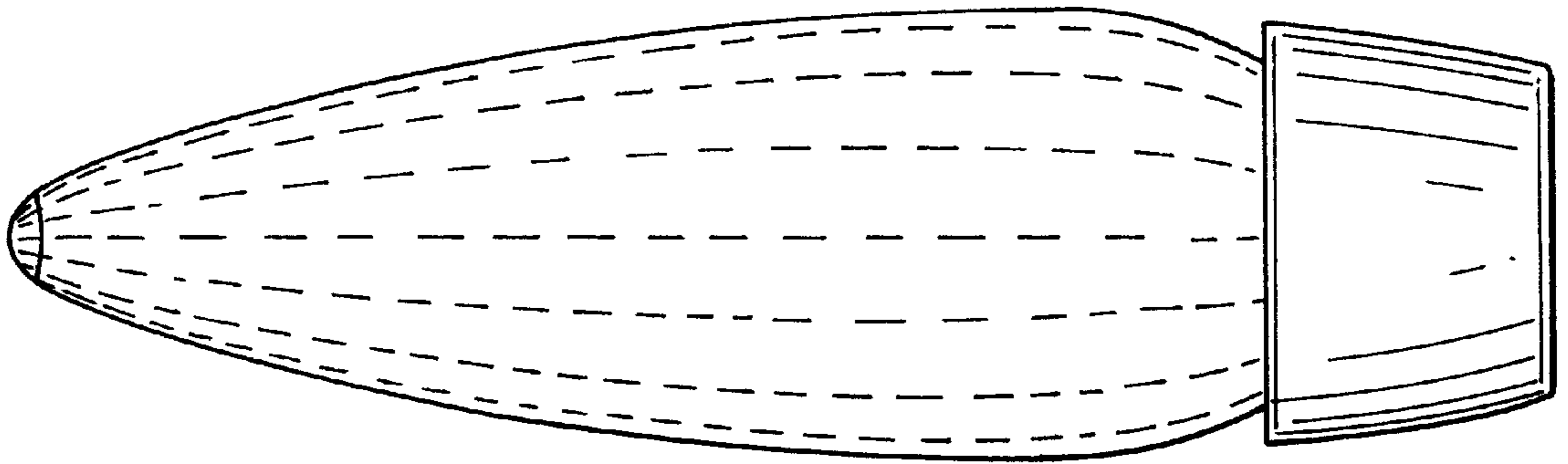

Fig. 5

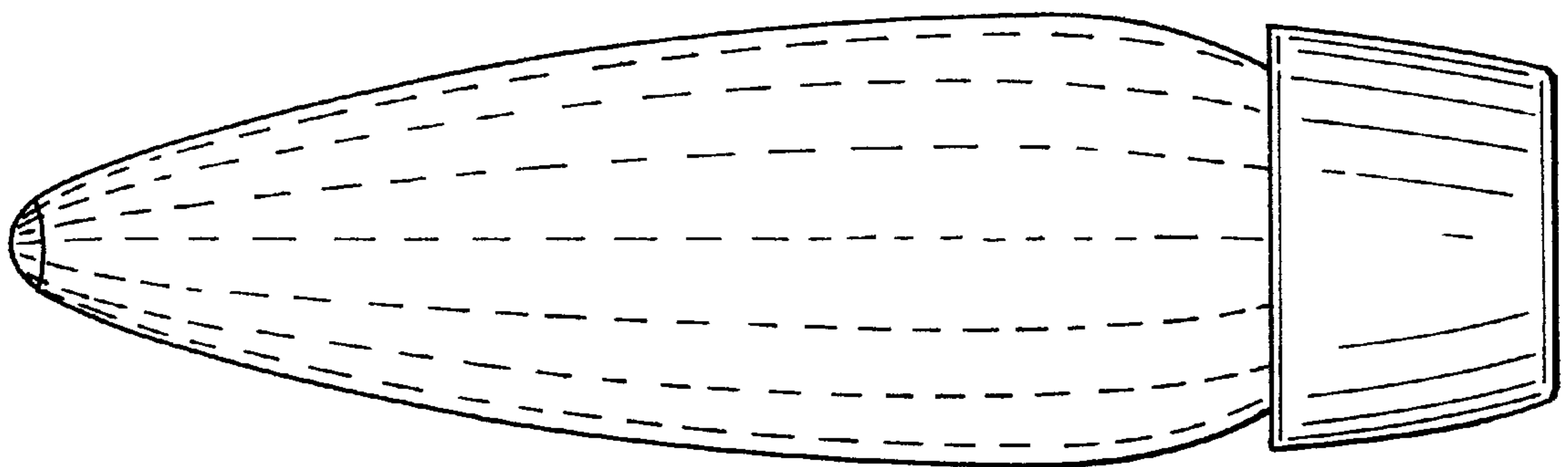

Fig. 6



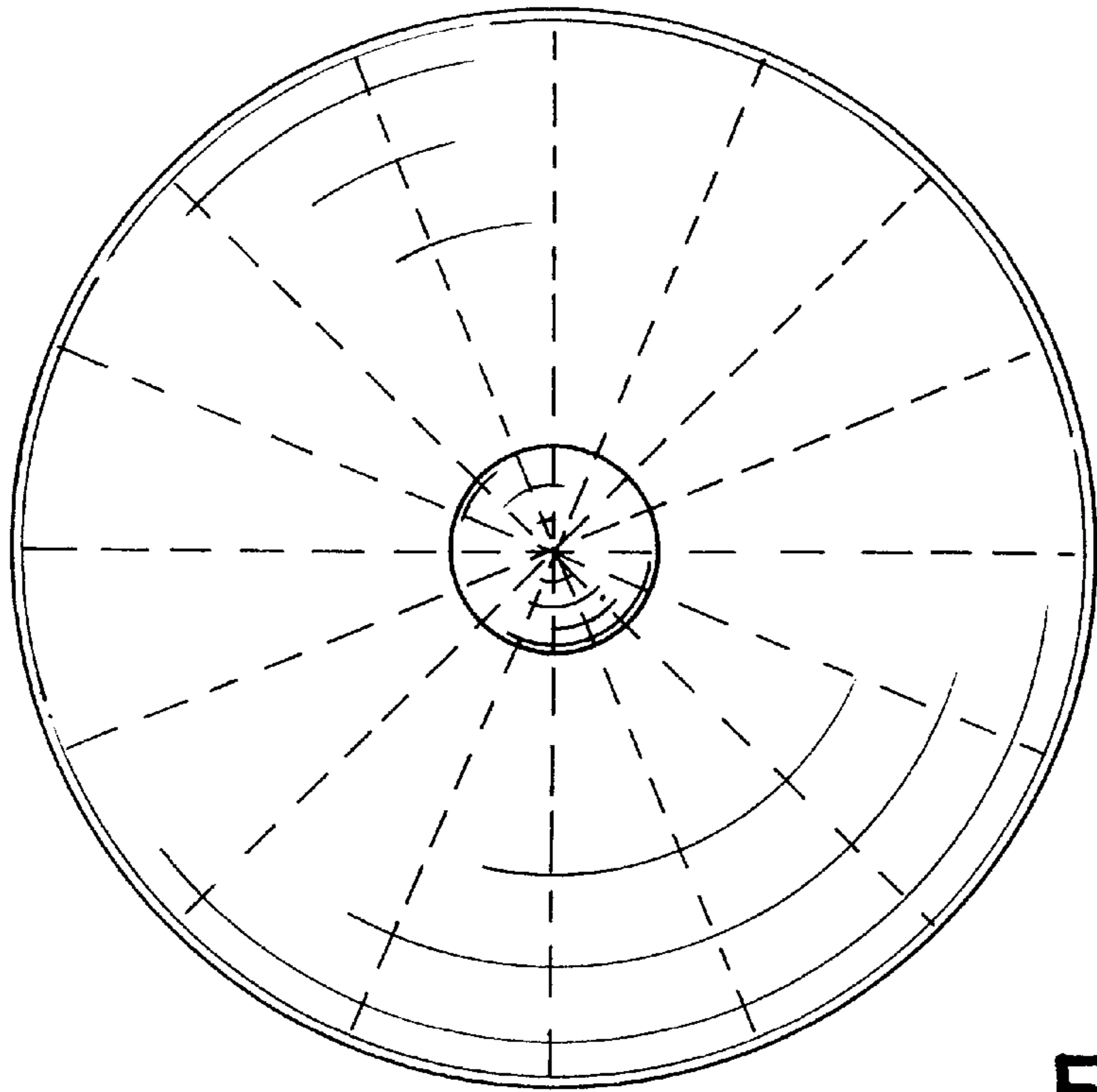

Fig. 7

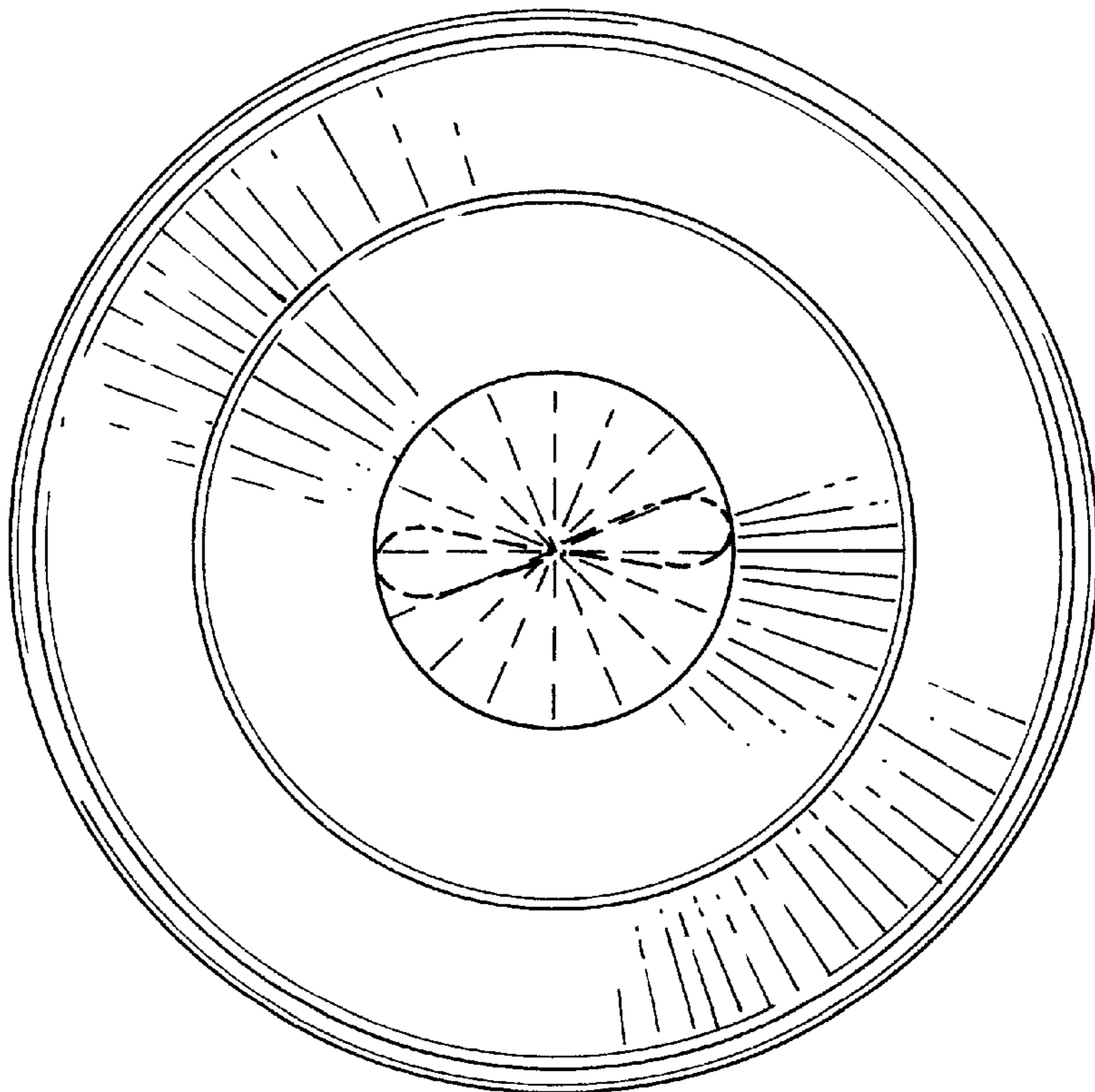

Fig. 8

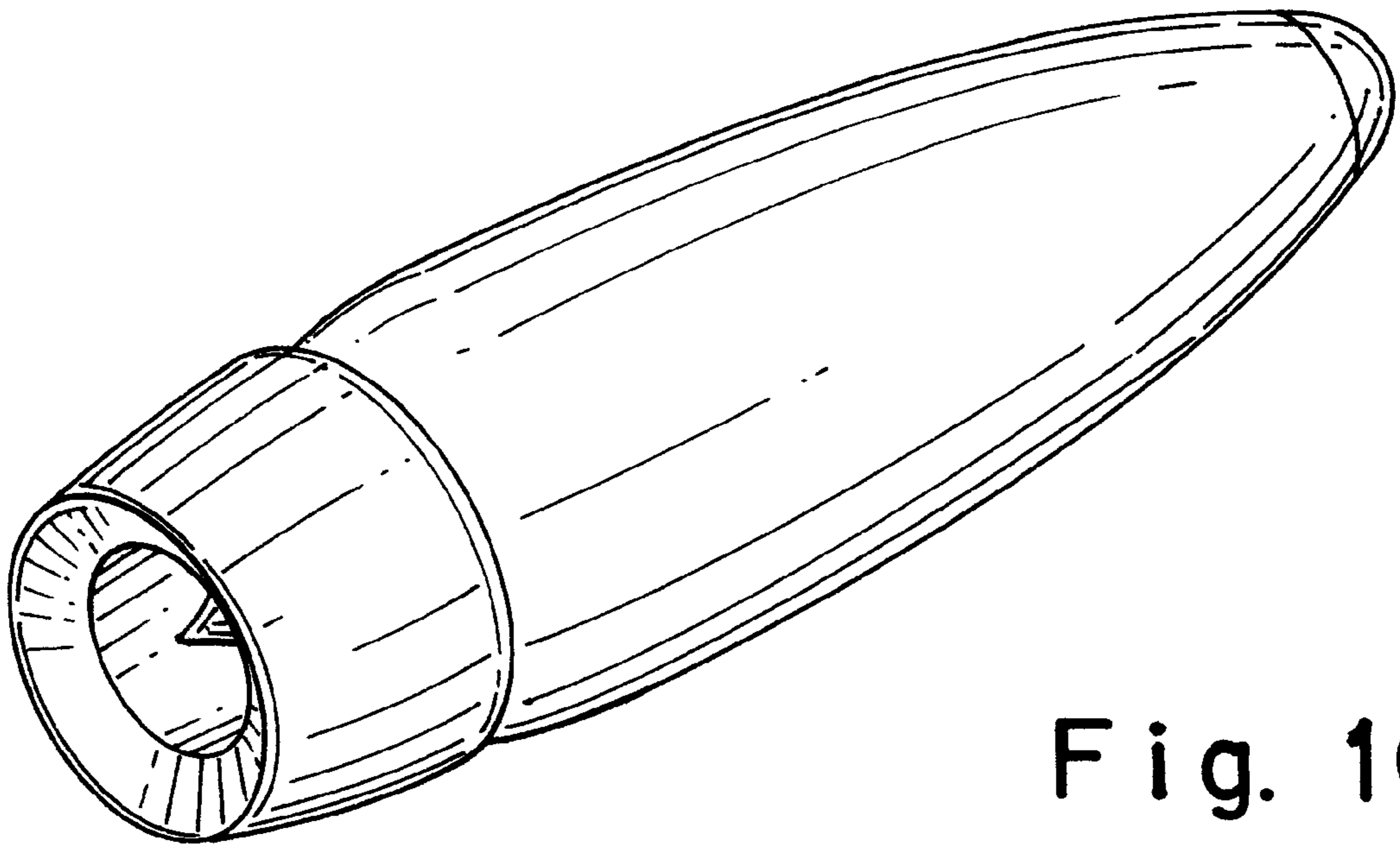

Fig. 10

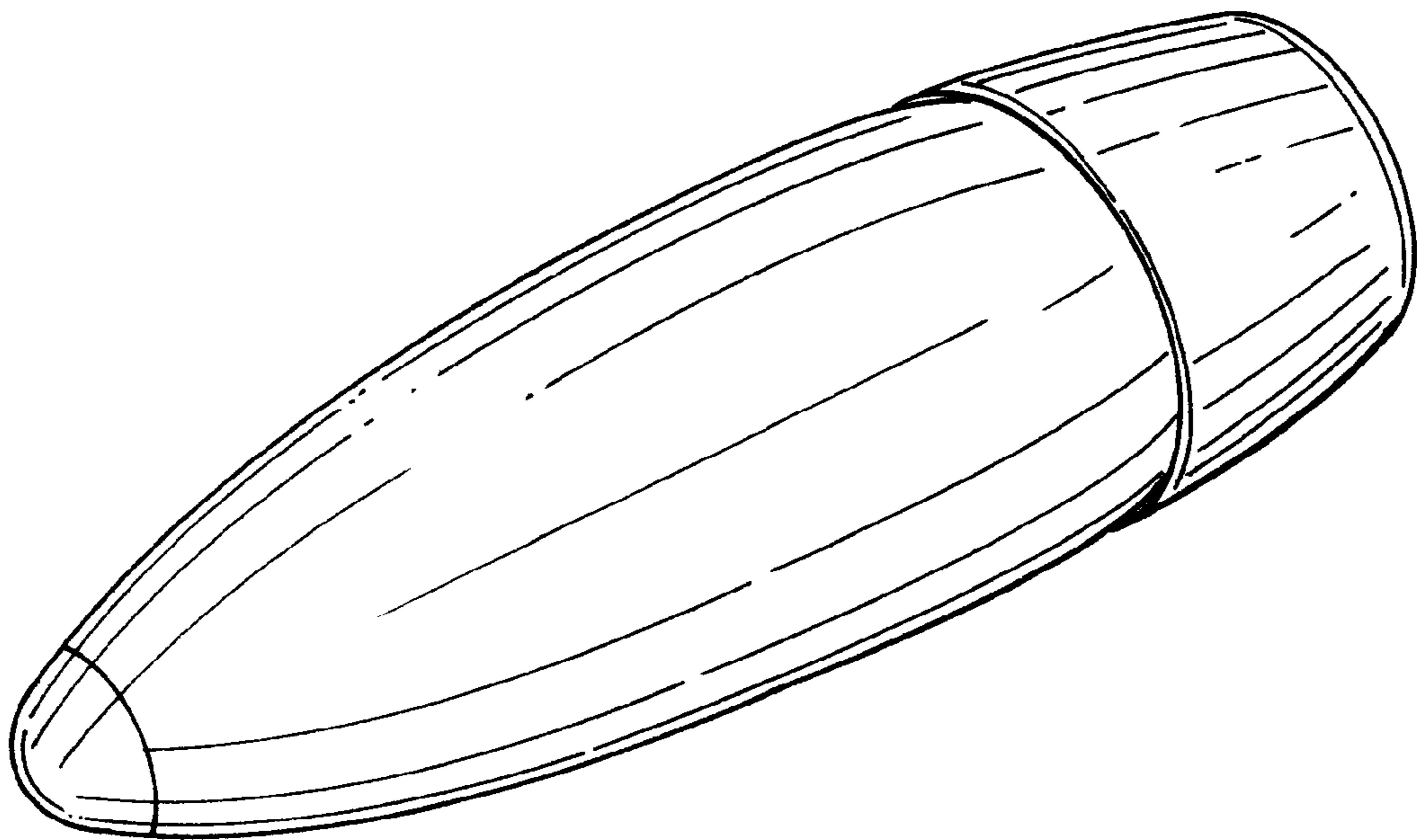

Fig. 9