



US00D427130S

United States Patent [19] Johnson

[11] Patent Number: Des. 427,130

[45] Date of Patent: ** Jun. 27, 2000

[54] VEHICLE WHEEL FRONT FACE

[75] Inventor: Ken Johnson, Fullerton, Calif.

[73] Assignee: American Racing Equipment, Inc.,
Rancho Dominguez, Calif.

[**] Term: 14 Years

[21] Appl. No.: 29/108,922

[22] Filed: Aug. 5, 1999

[51] LOC (7) Cl. 12-16

[52] U.S. Cl. D12/211

[58] Field of Search D12/204-213;
301/64.1, 65, 37.1

[56] **References Cited**

U.S. PATENT DOCUMENTS

D. 258,503	3/1981	Seiple	D12/211
D. 375,076	10/1996	Cattaneo	D12/211
D. 398,277	9/1998	Neeper	D12/209
D. 402,251	12/1998	Timm	D12/211
D. 405,749	2/1999	Kulla	D12/211

D. 409,132	5/1999	Cullen	D12/211
D. 409,552	5/1999	Chung	D12/211
D. 410,617	6/1999	Hussaini et al.	D12/209
D. 413,853	9/1999	Hale, Jr.	D12/211
D. 414,454	9/1999	Chung	D12/211

Primary Examiner—Cathron B. Matta
Assistant Examiner—Stacia Cadmus
Attorney, Agent, or Firm—Thompson Hine & Flory LLP

[57] **CLAIM**

The ornamental design for a vehicle wheel front face, as shown and described.

DESCRIPTION

FIG. 1 is a perspective view taken from the left hand side of my new vehicle wheel front face; and, FIG. 2 is a front elevational view thereof.

The broken lines adjacent to the spoke member in the center hub area define the bounds of the claimed design and form no part thereof while the remaining broken lines depict environment for illustrative purposes only and forms no part of the claimed design.

1 Claim, 2 Drawing Sheets

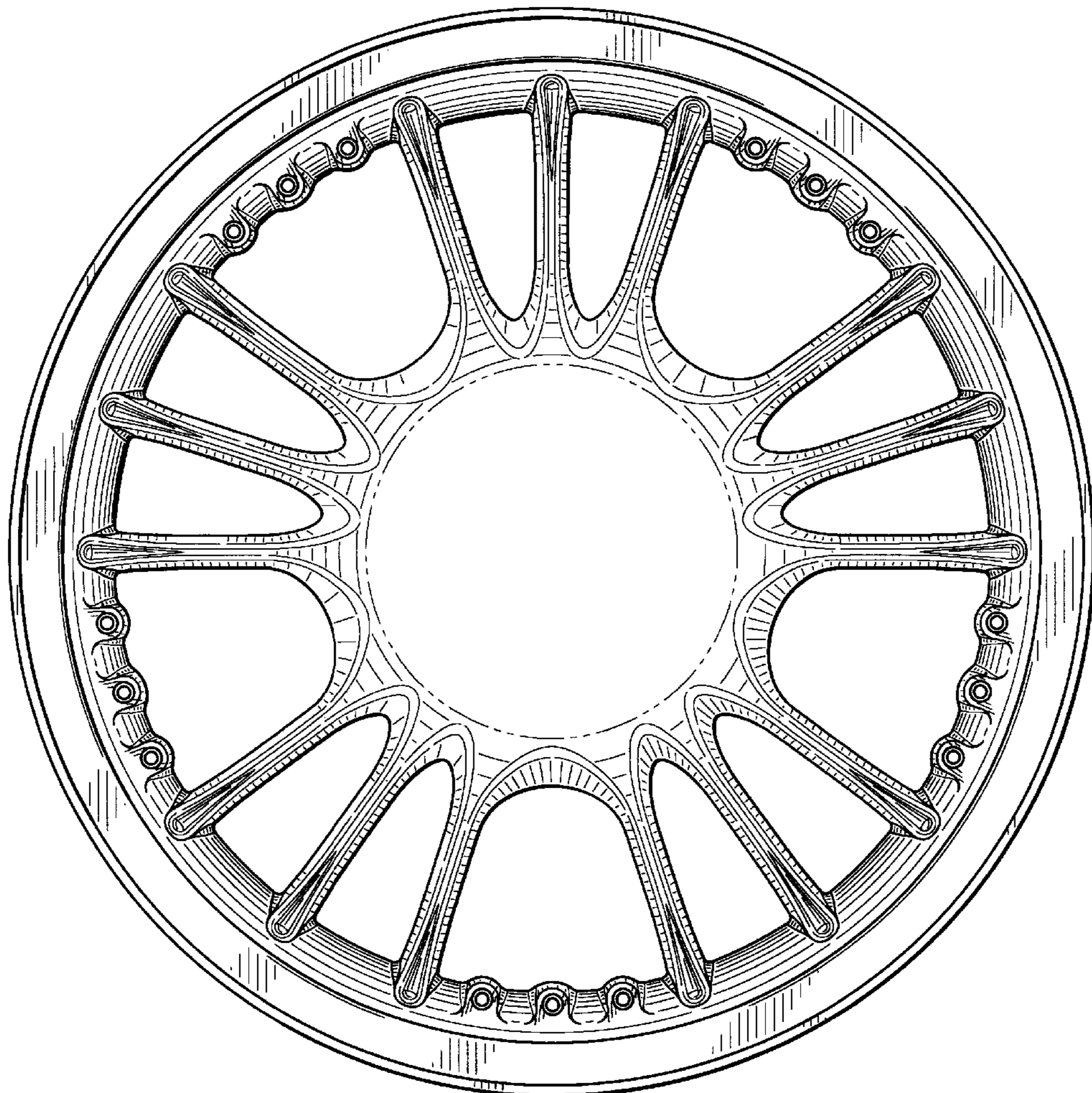

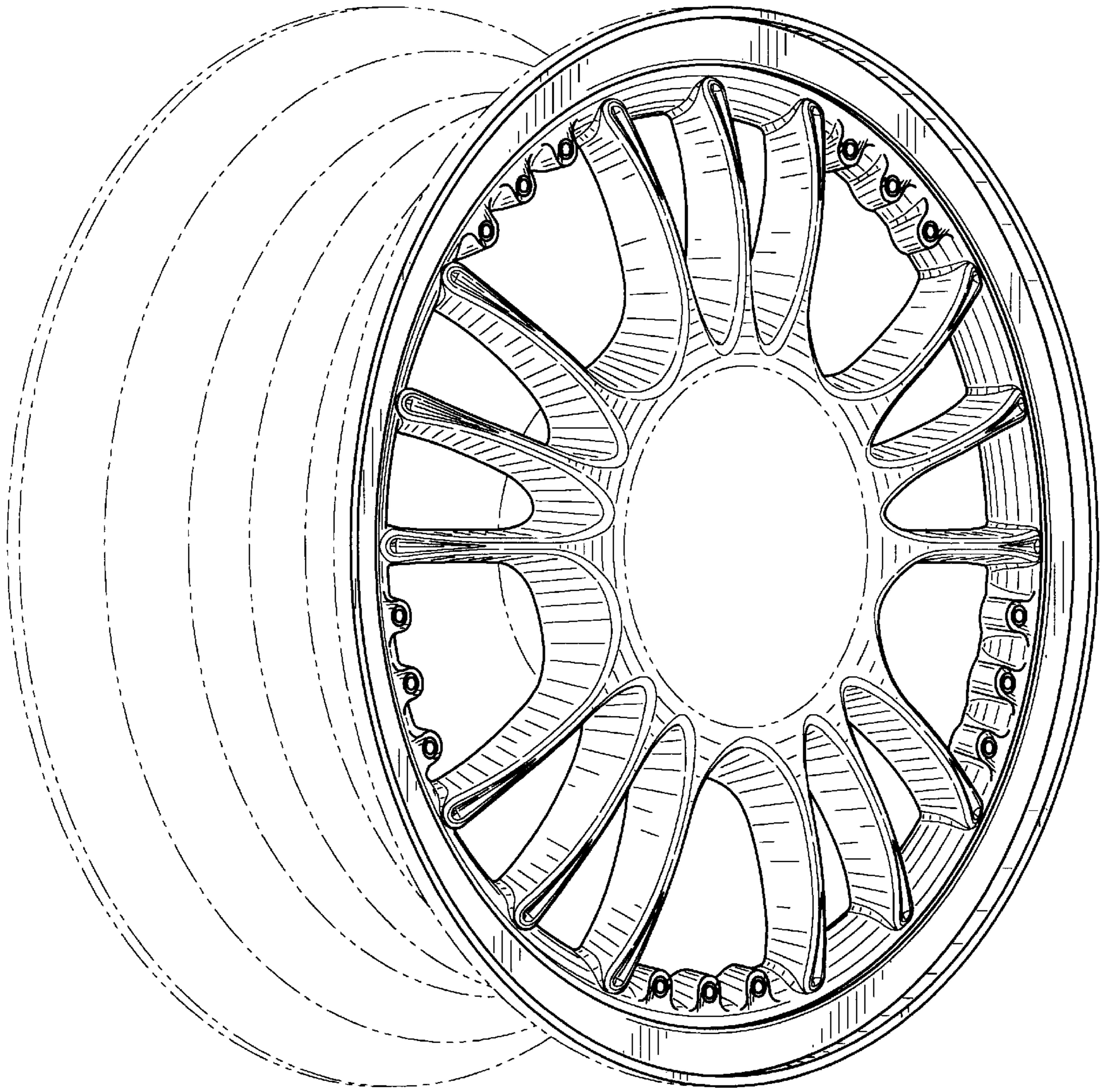

FIG. 1

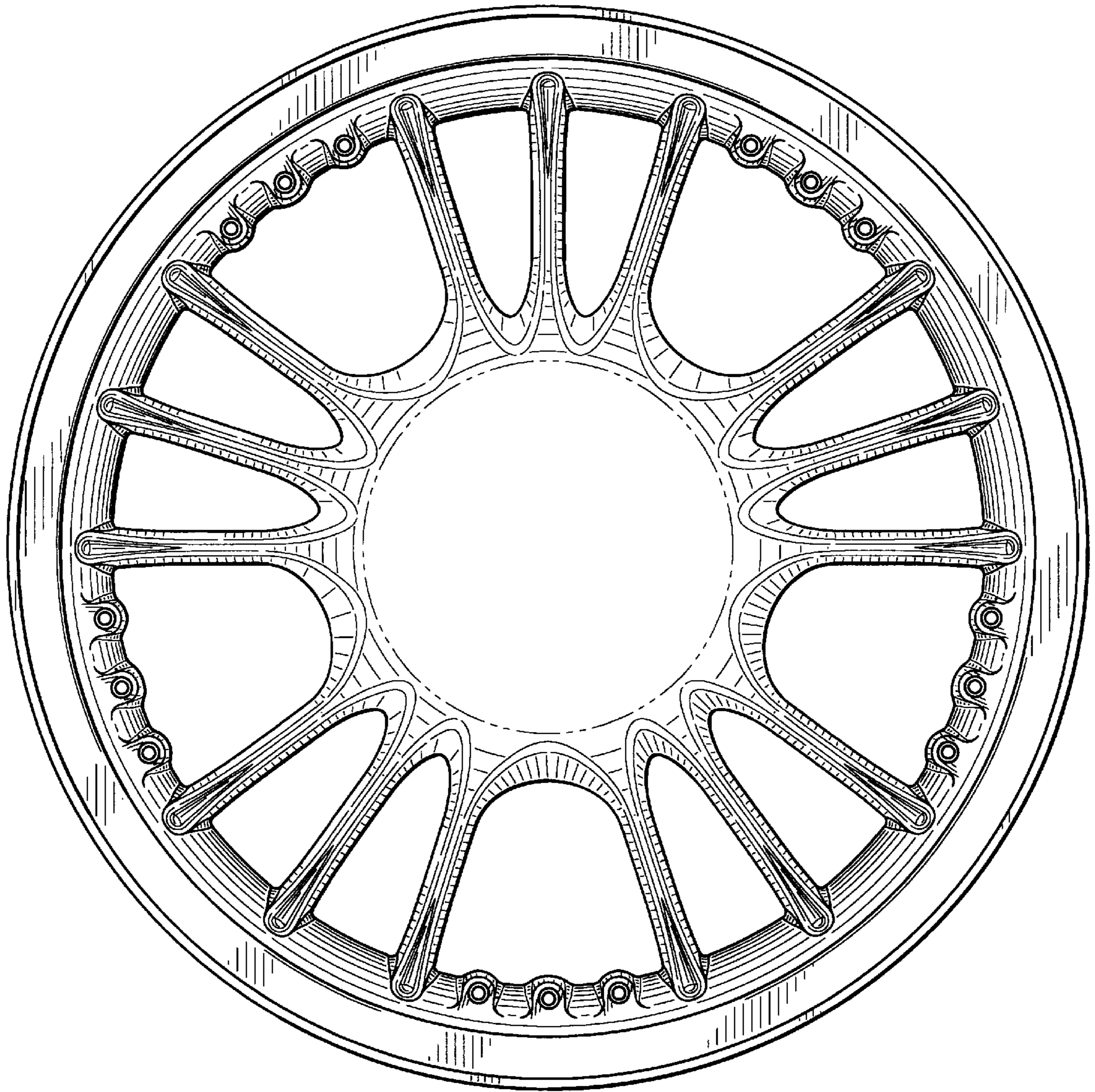

FIG. 2