



US00D427123S

# United States Patent [19]

Hoyle, Jr.

[11] **Patent Number: Des. 427,123**

[45] **Date of Patent: \*\* Jun. 27, 2000**

[54] **PORTION OF A TRUCK COWL HOOD**

[75] Inventor: **Frederick L. Hoyle, Jr.**, Pickerington, Ohio

[73] Assignee: **Reflexxion Automotive Products LLC**, Memphis, Tenn.

[\*\*] Term: **14 Years**

[21] Appl. No.: **29/115,347**

[22] Filed: **Dec. 13, 1999**

[51] **LOC (7) Cl.** ..... **12-16**

[52] **U.S. Cl.** ..... **D12/173**

[58] **Field of Search** ..... D12/173, 90-92;  
180/69.21, 69.2, 69.22, 69.25

[56] **References Cited**

**U.S. PATENT DOCUMENTS**

D. 353,124 12/1994 Benningfield ..... D12/173

D. 385,242 10/1997 Grabo et al. .... D12/173

D. 386,457 11/1997 Wittine ..... D12/173  
D. 391,309 2/1998 Wittine ..... D12/173  
D. 416,524 11/1999 Gabath ..... D12/173  
D. 418,465 1/2000 Alfes ..... D12/173

*Primary Examiner*—Melody N. Brown  
*Attorney, Agent, or Firm*—Gifford, Krass, Groh, Sprinkle, Anderson & Citkowski, P.C.

[57] **CLAIM**

I claim the ornamental design for a portion of a truck cowl hood, as shown and described.

**DESCRIPTION**

FIG. 1 is a front elevational view of a portion of a truck cowl hood showing my new design; the broken lines are shown for illustrative purposes only and form no part of the claimed design;

FIG. 2 is a front and left side perspective view thereof; and, FIG. 3 is a left side elevational view thereof, the right side being a mirror image of that shown.

**1 Claim, 1 Drawing Sheet**

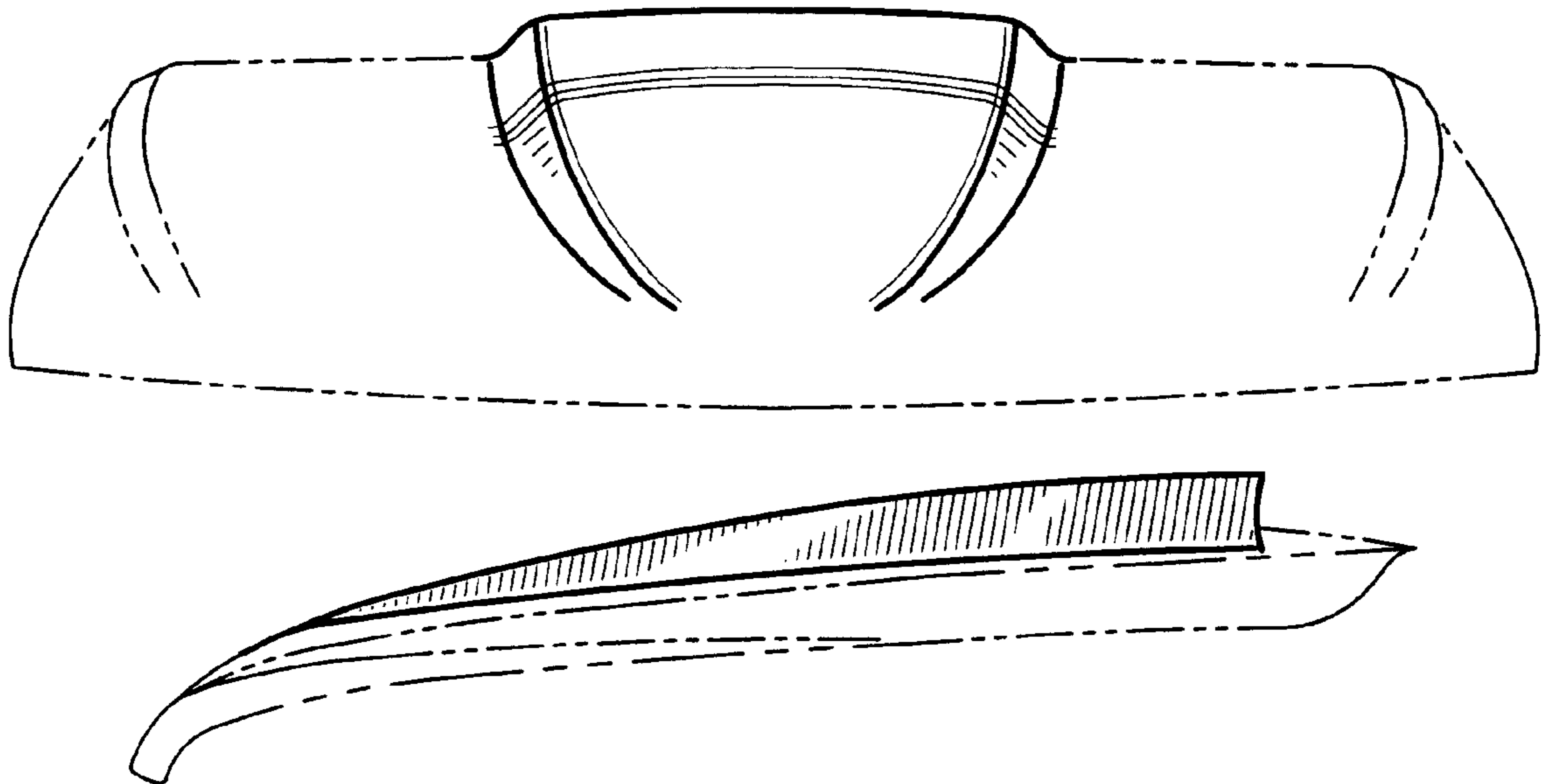

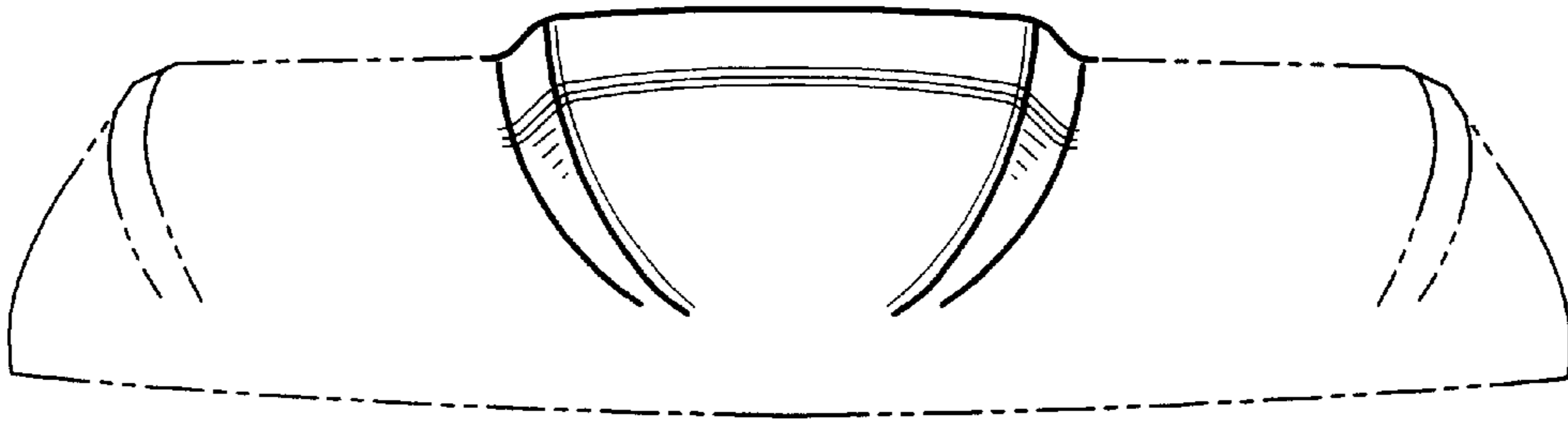

Fig-1

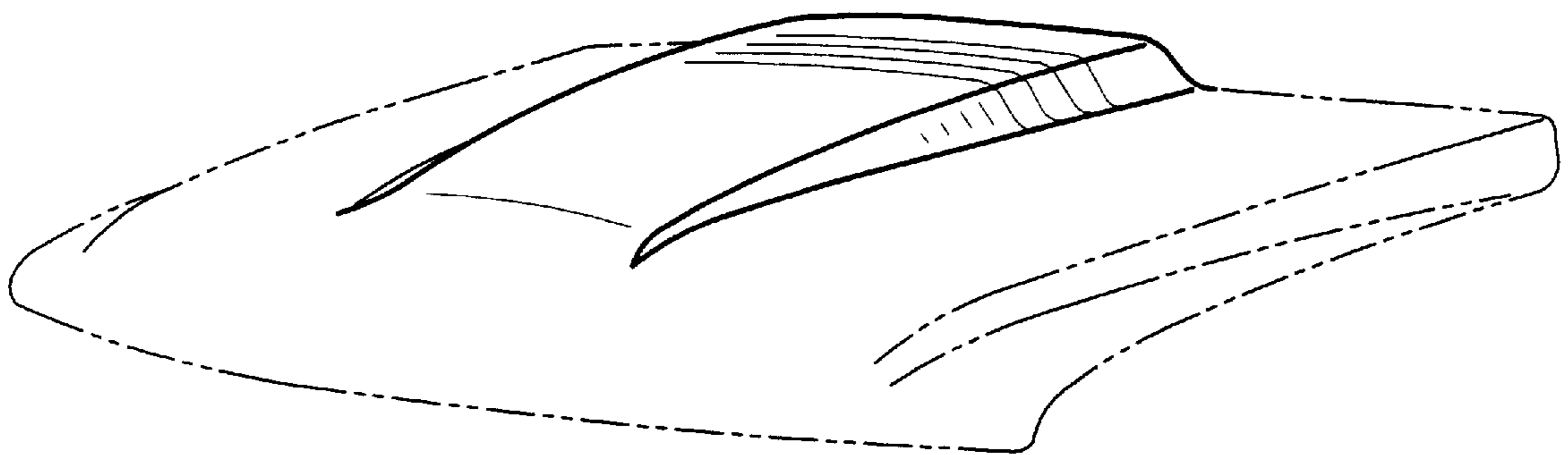

Fig-2

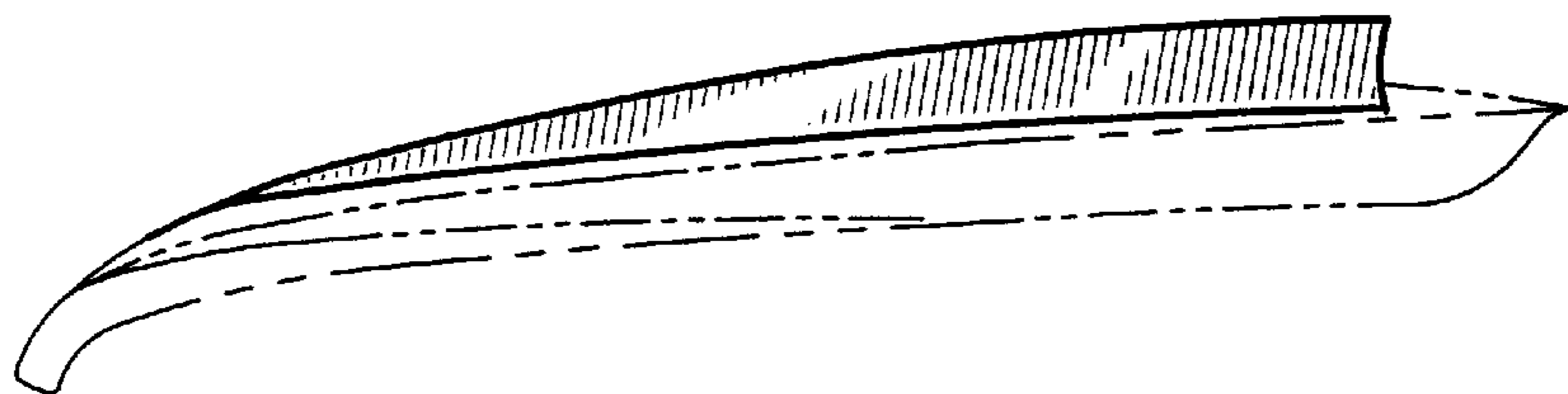

Fig-3

UNITED STATES PATENT AND TRADEMARK OFFICE  
**CERTIFICATE OF CORRECTION**

PATENT NO. : Des 427,123  
DATED : June 27, 2000  
INVENTOR(S) : Frederick L. Hoyle, Jr.

Page 1 of 3

It is certified that error appears in the above-identified patent and that said Letters Patent is hereby corrected as shown below:

Description.

After "Fig. 2 is a front and left side perspective thereof;" delete -- and --  
After "Fig. 3 is a left side elevation view thereof, the right side being a mirror image of that shown." insert

-- Fig. 4 is a formal perspective view forming a part of a second preferred embodiment of the present design;

Fig. 5 is a further frontal elevational view taken at a left side angle of the embodiment shown in Fig. 4; and

Fig. 6 is an isometric left side view forming a part of the second preferred embodiment of the present design, a corresponding right side being a mirror image thereof. --

Drawings.

After Figure "3" insert the sheet of drawings containing Figures -- 4, 5, and 6 --, so that the sheets of drawing appear as shown on the attached pages.

Signed and Sealed this

Nineteenth Day of February, 2002

Attest:

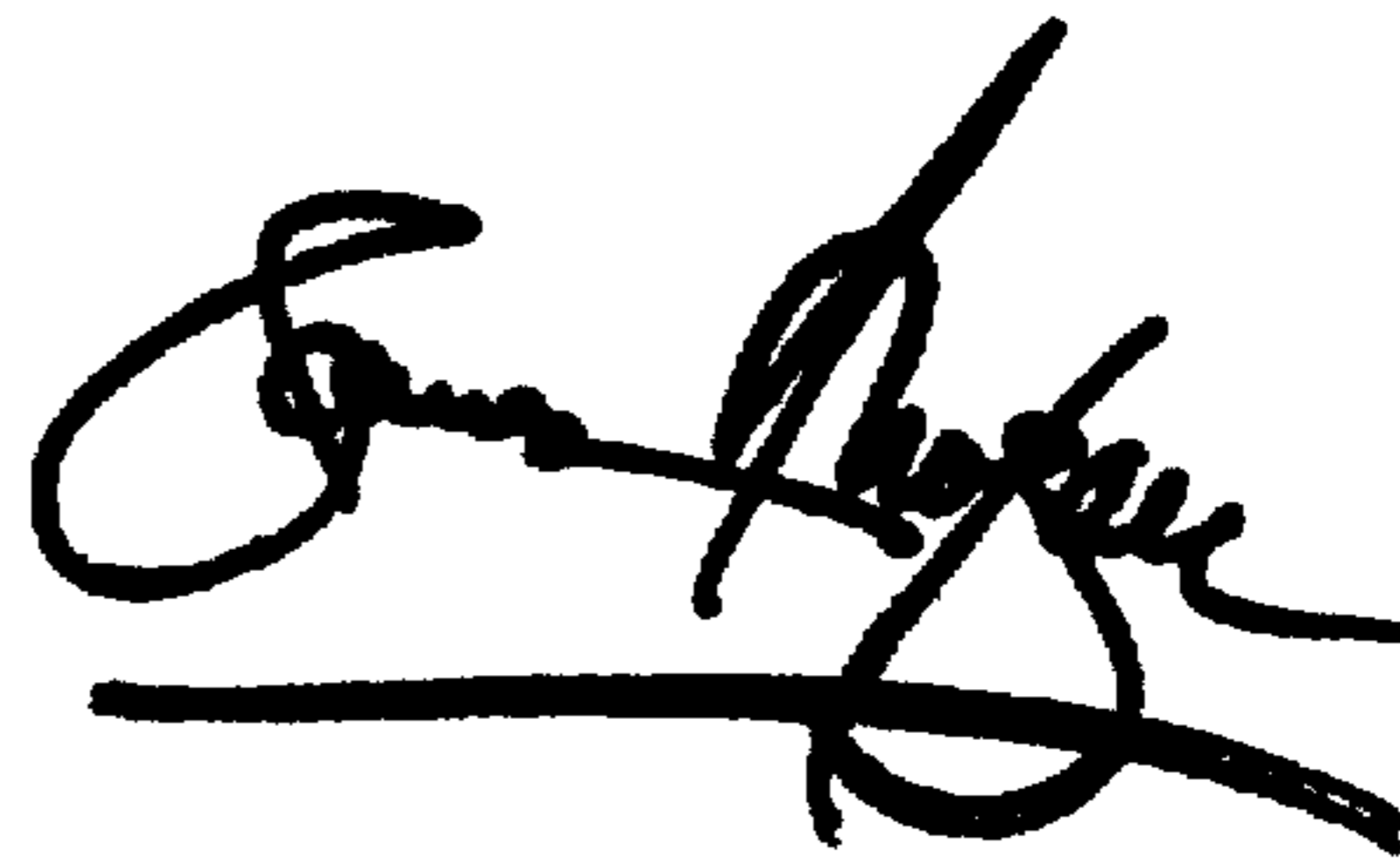

Attesting Officer

JAMES E. ROGAN  
Director of the United States Patent and Trademark Office

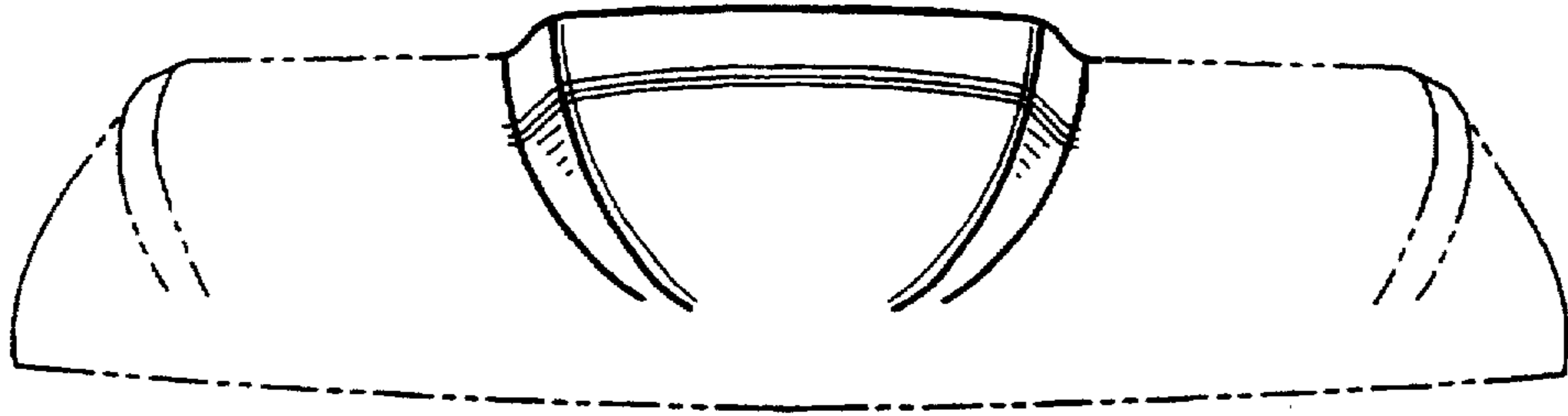

Fig-1

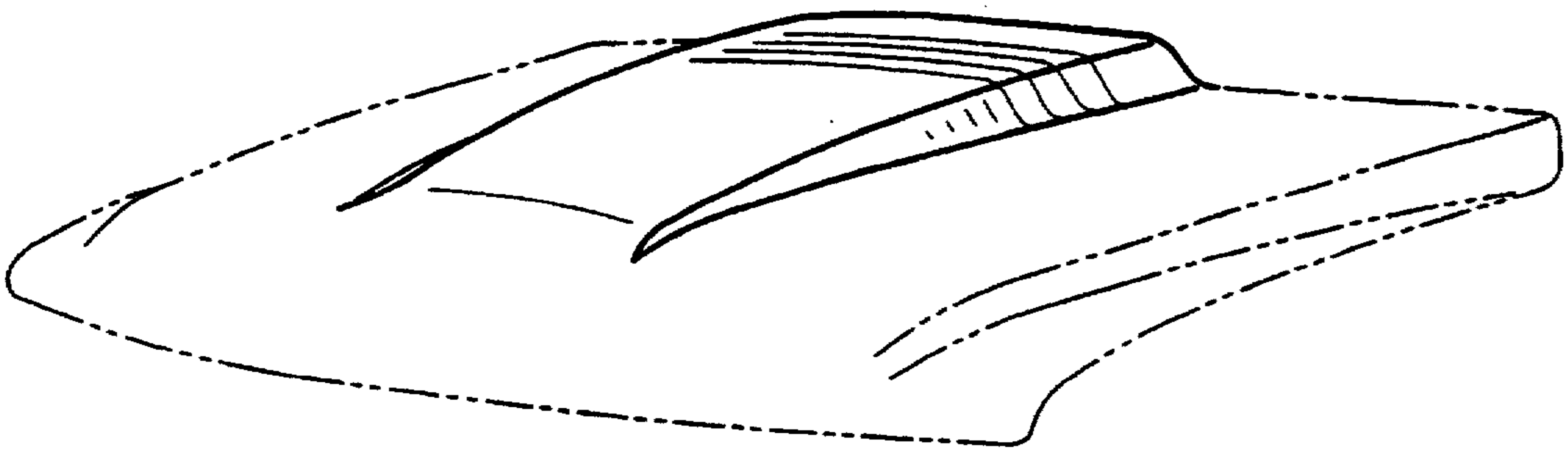

Fig-2

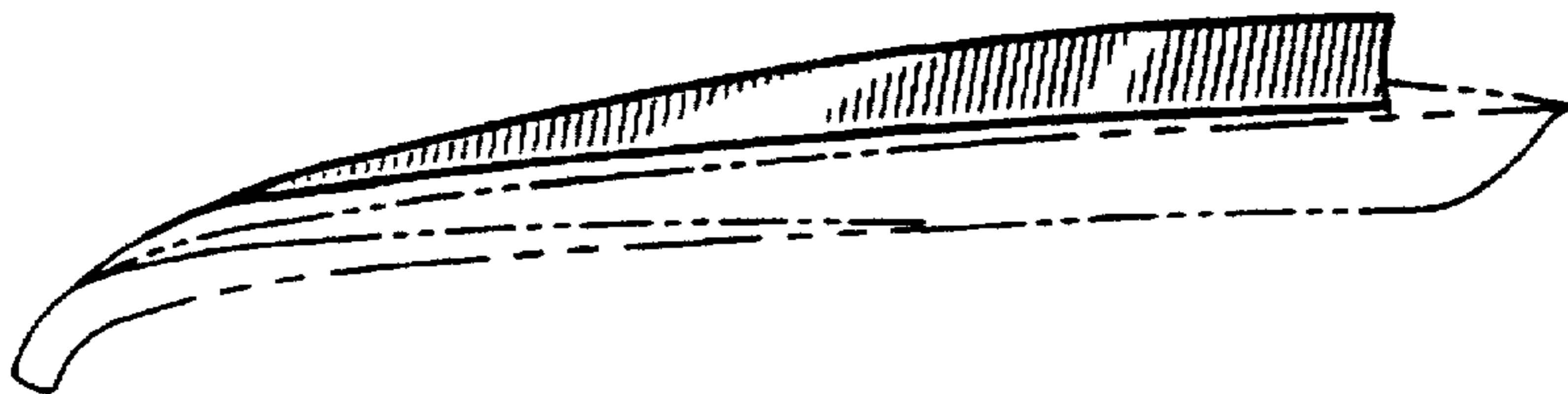

Fig-3

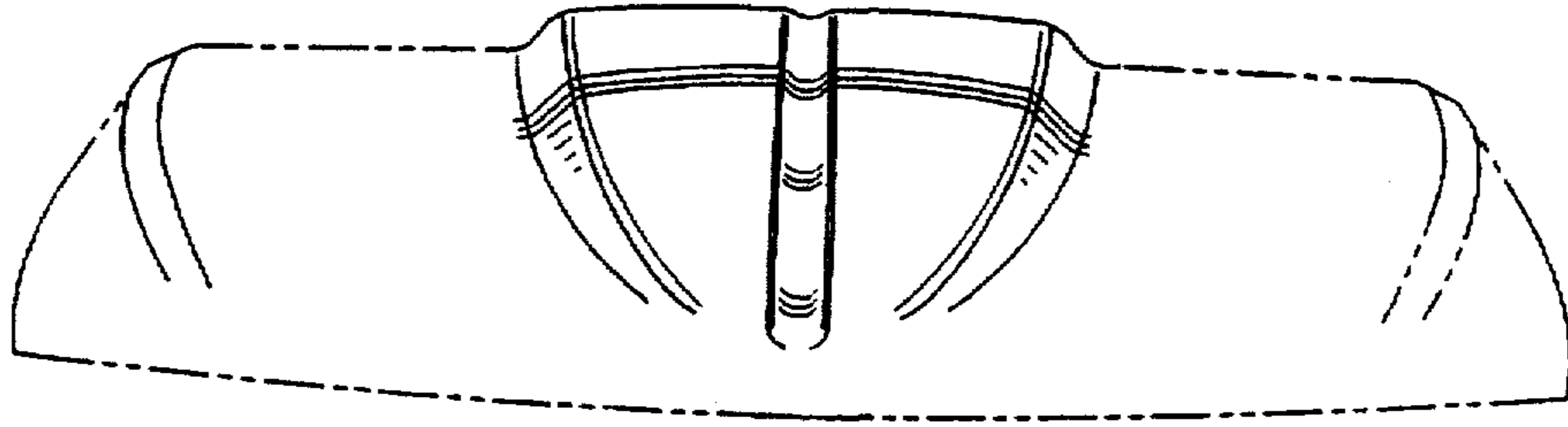

Fig-4

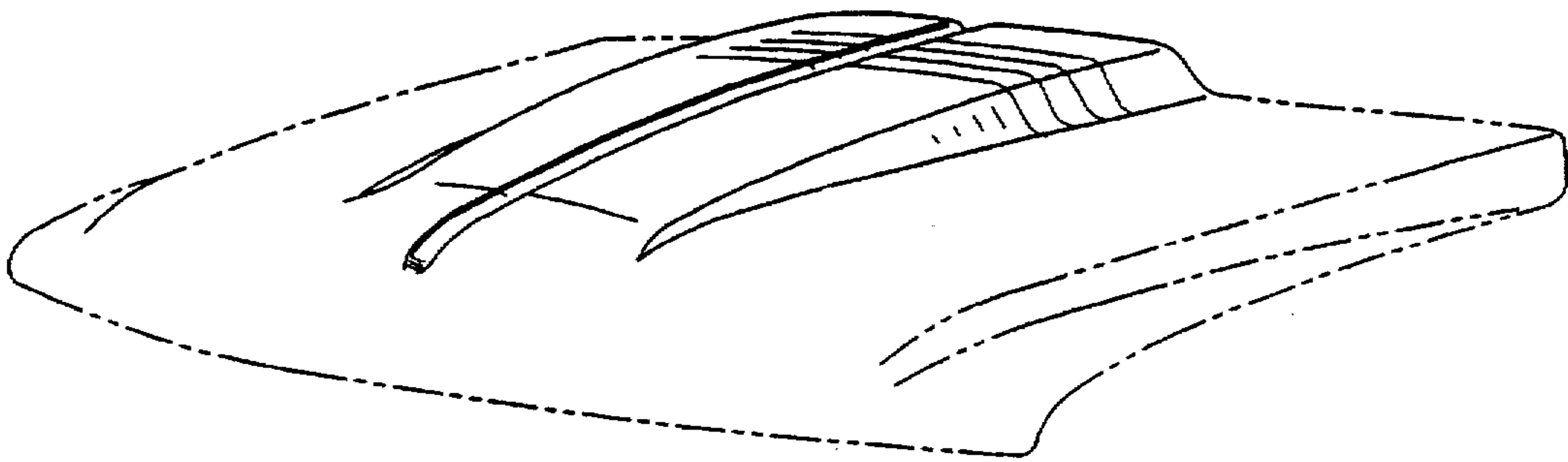

Fig-5

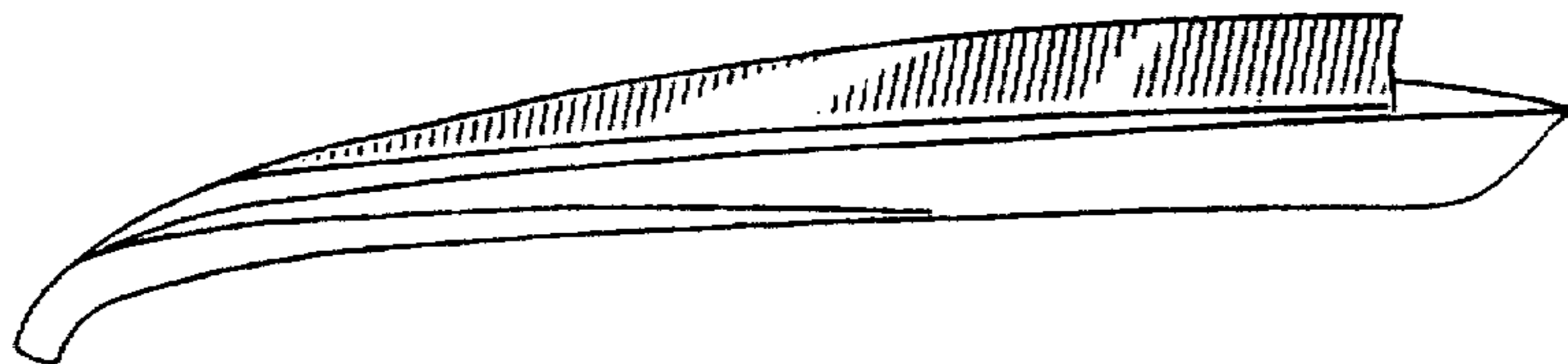

Fig-6



US00D427123C1

(12) **REEXAMINATION CERTIFICATE** (4596th)

**United States Patent**  
**Hoyle, Jr.**

(10) **Number:** **US D427,123 C1**  
(45) **Certificate Issued:** **Jun. 11, 2002**

(54) **PORTION OF A TRUCK COWL HOOD**

(56)

**References Cited**

(75) **Inventor:** **Frederick L. Hoyle, Jr.**, Pickerington, OH (US)

(73) **Assignee:** **Reflexxion Automotive Products LLC**, Memphis, TN (US)

**Reexamination Request:**

No. 90/005,821, Sep. 18, 2000

**Reexamination Certificate for:**

Patent No.: **Des. 427,123**  
Issued: **Jun. 27, 2000**  
Appl. No.: **29/115,347**  
Filed: **Dec. 13, 1999**

**U.S. PATENT DOCUMENTS**

5,136,276 A	8/1992	Wayne	340/461
5,157,377 A	10/1992	Wayne	340/468
D342,709 S	12/1993	Cervini	D12/173
5,292,166 A	3/1994	Emery	296/91
5,482,336 A	1/1996	Rouse et al.	293/115
D391,909 S	3/1998	Wittine	D12/173
D399,463 S	10/1998	Grabo et al.	D12/173
D427,123 S	6/2000	Hoyle, Jr.	D12/173
D429,670 S	8/2000	Hoyle, Jr.	D12/173
D430,084 S	8/2000	Hoyle, Jr.	D12/173
D430,085 S	8/2000	Hoyle, Jr.	D12/173
D433,359 S	11/2000	Hoyle, Jr.	D12/173
D434,709 S	12/2000	Hoyle, Jr.	D12/173

**OTHER PUBLICATIONS**

Certificate of Correction issued Feb. 19, 2002.

- (51) **LOC (7) Cl.** ..... **12-173**
- (52) **U.S. Cl.** ..... **D12/173**
- (58) **Field of Search** ..... D12/173, 90, 91,  
D12/92, 196; 180/6.86, 6.92, 6.21, 69.2,  
69.22

Brochure entitled "1998 Chrome & Steel Accessory Guide" Cowl Hoods, Steps, Bumpers, Air Dams by Reflexxion Automotive Products.

*Primary Examiner*—Susan J. Lucas

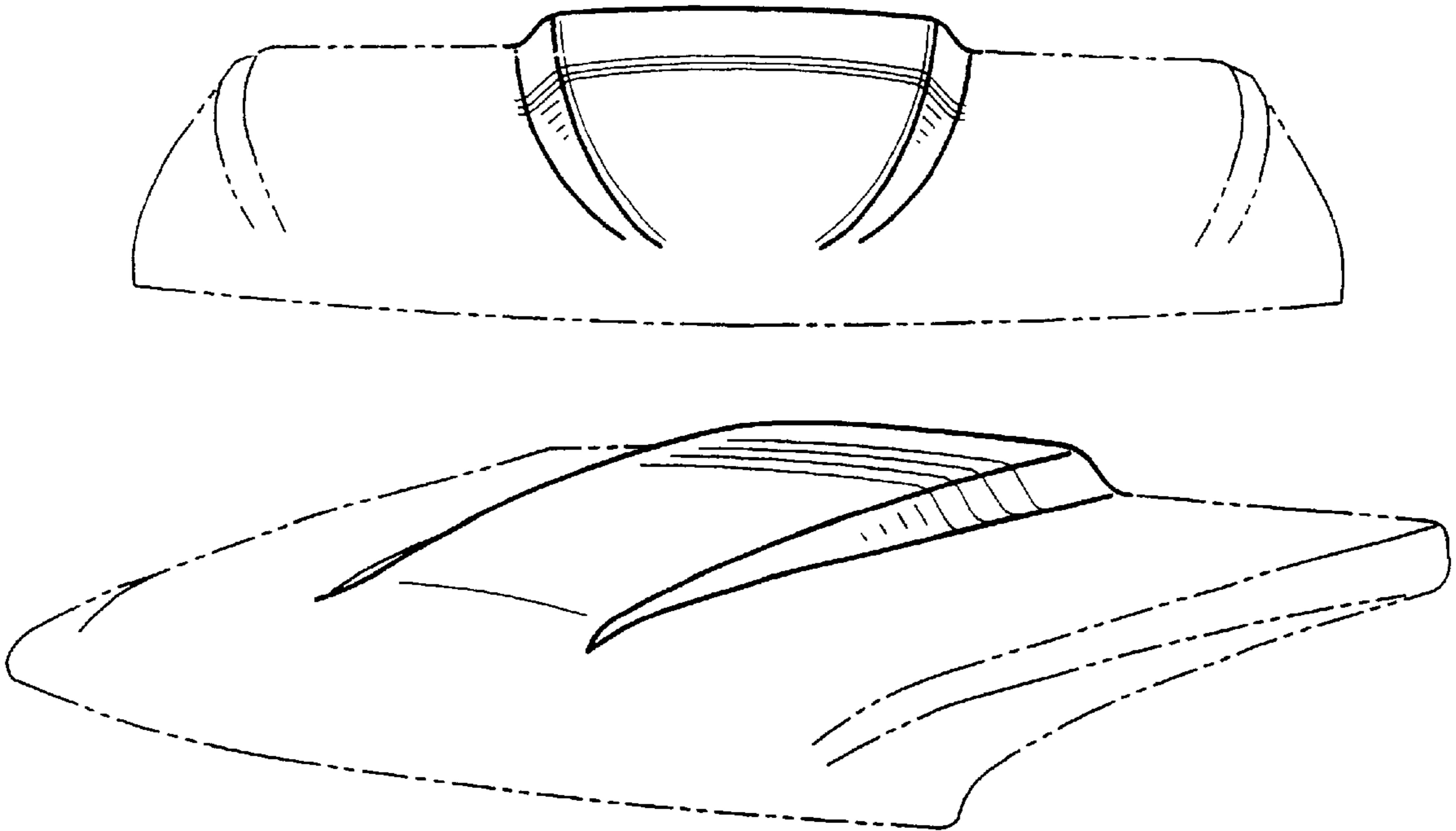

**1**  
**REEXAMINATION CERTIFICATE**  
**ISSUED UNDER 35 U.S.C. 307**

NO AMENDMENTS HAVE BEEN MADE TO  
THE PATENT

**2**  
AS A RESULT OF REEXAMINATION, IT HAS BEEN  
DETERMINED THAT:

5 The patentability of the single design claim is confirmed.

\* \* \* \* \*