



US00D426931S

United States Patent [19] McKoy

[11] Patent Number: **Des. 426,931**

[45] Date of Patent: **** Jun. 20, 2000**

[54] **PORTABLE FOOT PEDAL OPERATED
AUTOMOBILE JACK**

5,522,583 6/1996 Martin 254/93 H
5,524,868 6/1996 Decker et al. 254/93 H

[76] Inventor: **Earl McKoy**, P.O. Box 2088,
Lillington, N.C. 27546

Primary Examiner—Susan J. Lucas
Assistant Examiner—Cynthia E. Ramirez
Attorney, Agent, or Firm—Dorothy S. Morse

[**] Term: **14 Years**

[57] CLAIM

[21] Appl. No.: **29/103,391**

The ornamental design for a portable foot pedal operated automobile jack, as shown and described.

[22] Filed: **Apr. 14, 1999**

DESCRIPTION

[51] **LOC (7) Cl.** **12-05**

[52] **U.S. Cl.** **D34/31**

[58] **Field of Search** D34/31; 254/8 B,
254/8 R, 11, 84, 88, 93 H, 813, 120, 124,
426, 126, DIG. 1, 133, 134

FIG. 1 is a perspective view of a first embodiment of the invention with its hydraulic cylinder centrally attached to the base support.

FIG. 2 is a front view of the first embodiment.

FIG. 3 is a back view of the first embodiment.

FIG. 4 is a right side view of the first embodiment.

FIG. 5 is a left side view of the first embodiment.

FIG. 6 is a top view of the first embodiment.

FIG. 7 is a bottom view of the first embodiment.

FIG. 8 is a perspective view of a second embodiment of the invention with its hydraulic cylinder positioned adjacent to one end of the base support.

FIG. 9 is a front view of the second embodiment.

FIG. 10 is a back view of the second embodiment.

FIG. 11 is a right side view of the second embodiment.

FIG. 12 is a left side view of the second embodiment.

FIG. 13 is a top view of the second embodiment; and,

FIG. 14 is a bottom view of the second embodiment.

[56] References Cited

U.S. PATENT DOCUMENTS

D. 95,744	5/1935	Hein	D34/31
D. 96,568	8/1935	Werner	D34/31
D. 231,338	4/1974	Fitzpatrick	D34/31
D. 274,668	7/1984	Eliasson	D34/31
D. 327,354	6/1992	Inman	D34/31
D. 327,764	7/1992	Davis	D34/31
D. 345,844	4/1994	Steele	D34/31
D. 348,966	7/1994	Guyton	D34/31
D. 396,926	8/1998	Undrhill et al.	D34/31
D. 396,927	8/1998	Tersingi et al.	D34/31
2,412,414	12/1946	Mueller	254/8 R
2,469,670	5/1949	Thompson	254/84
4,202,514	5/1980	Chen	254/93 H
4,509,723	4/1985	Shimura	254/93 H

1 Claim, 4 Drawing Sheets

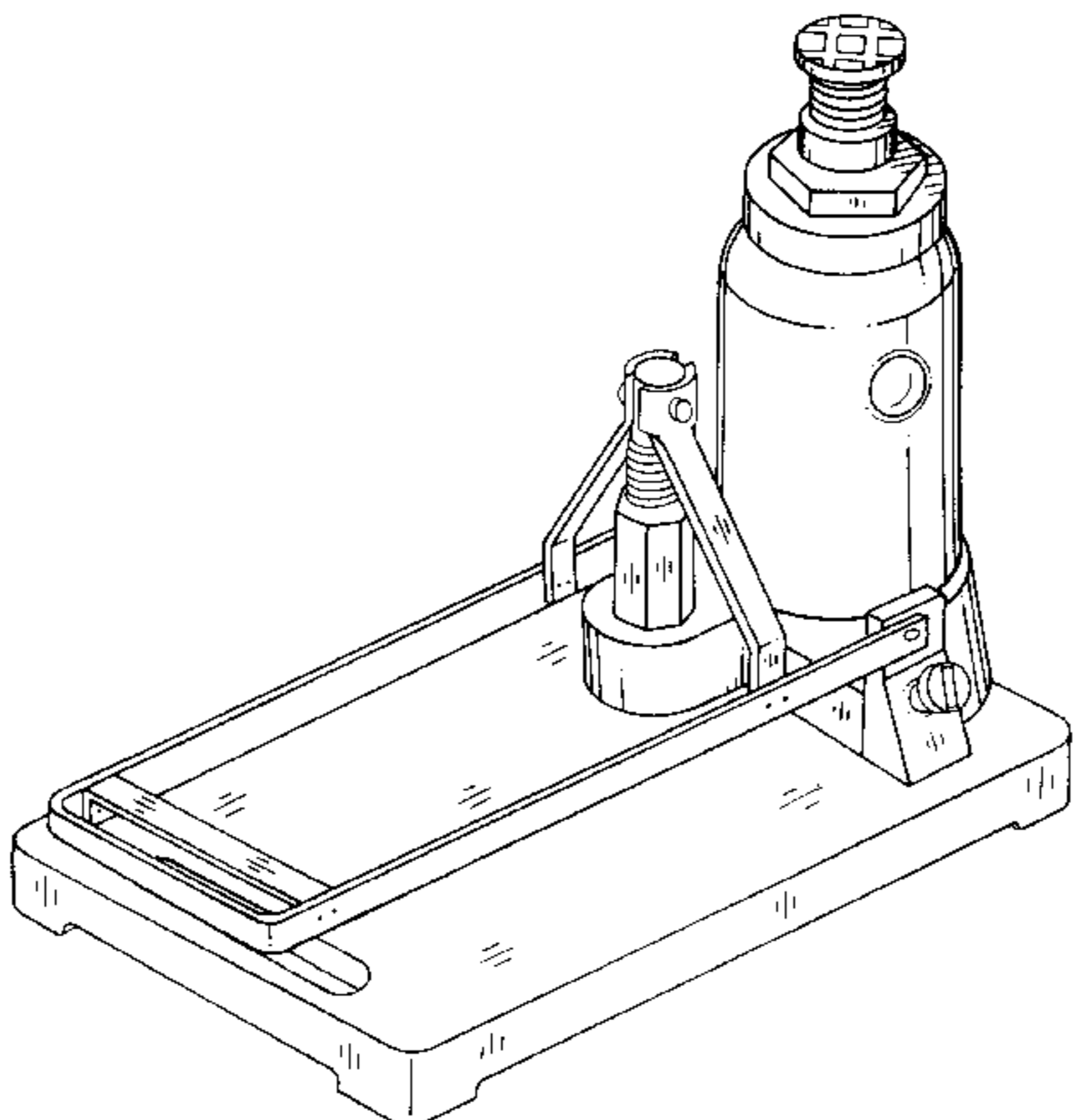
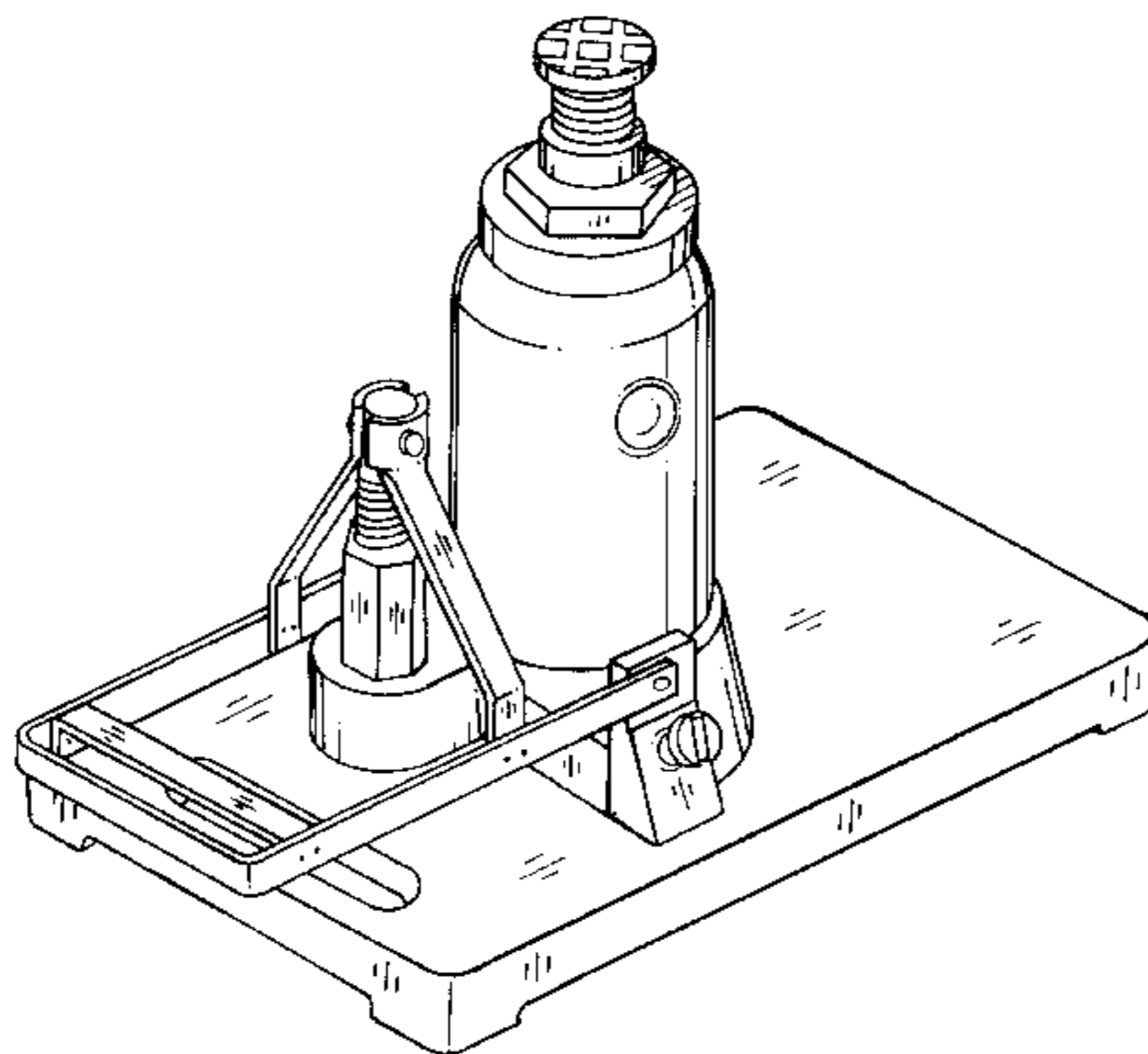

FIG. 1

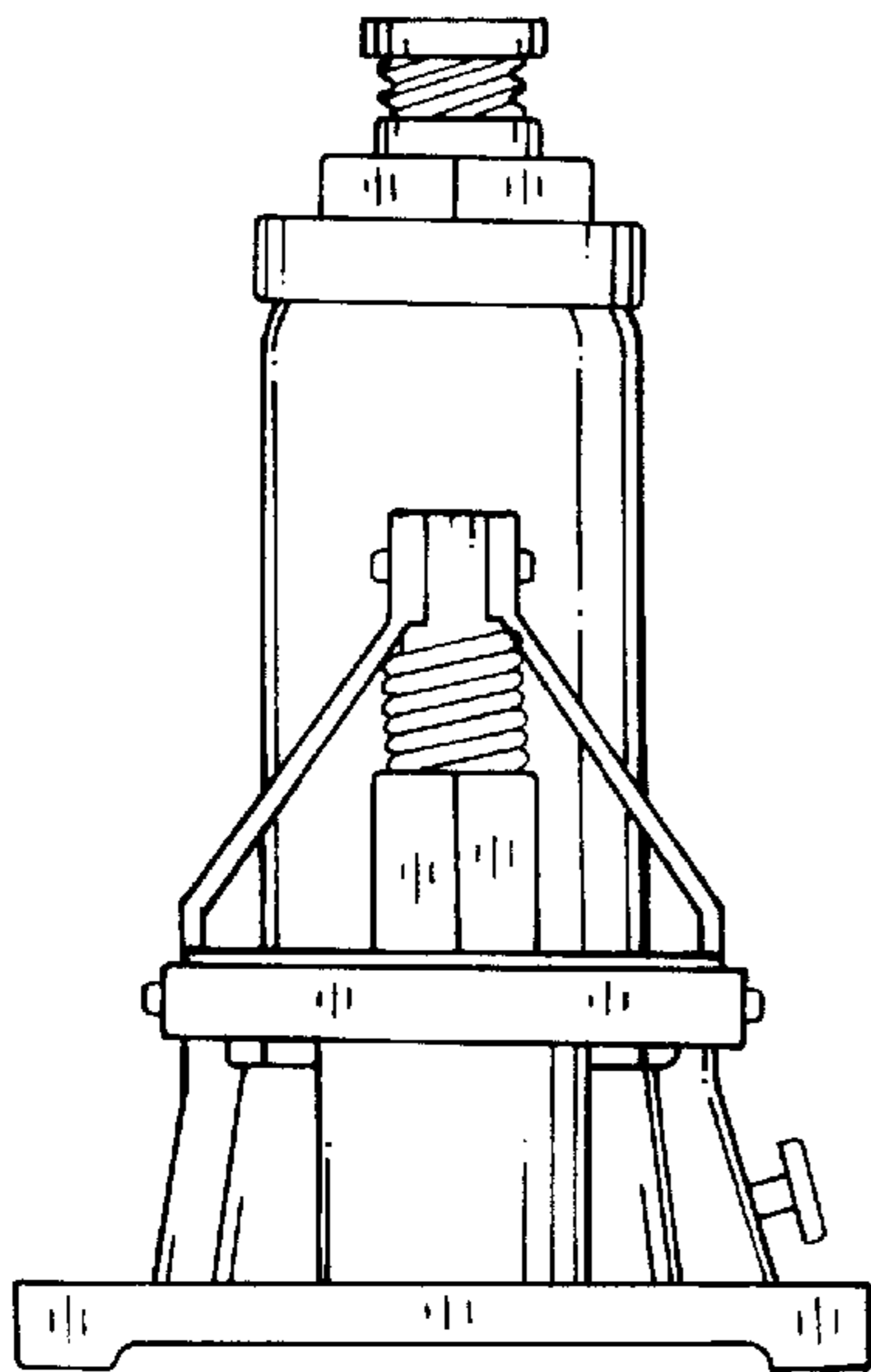
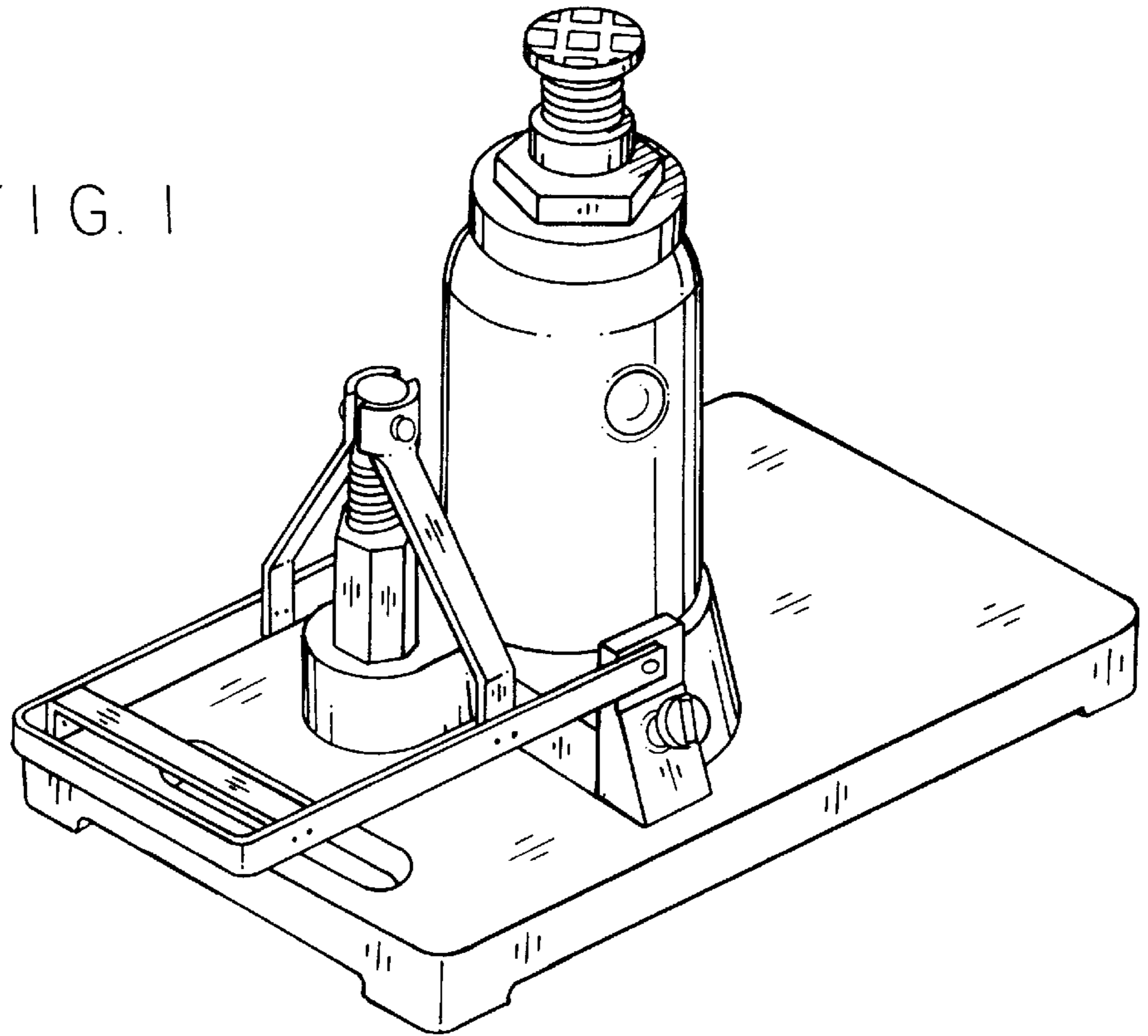

FIG. 2

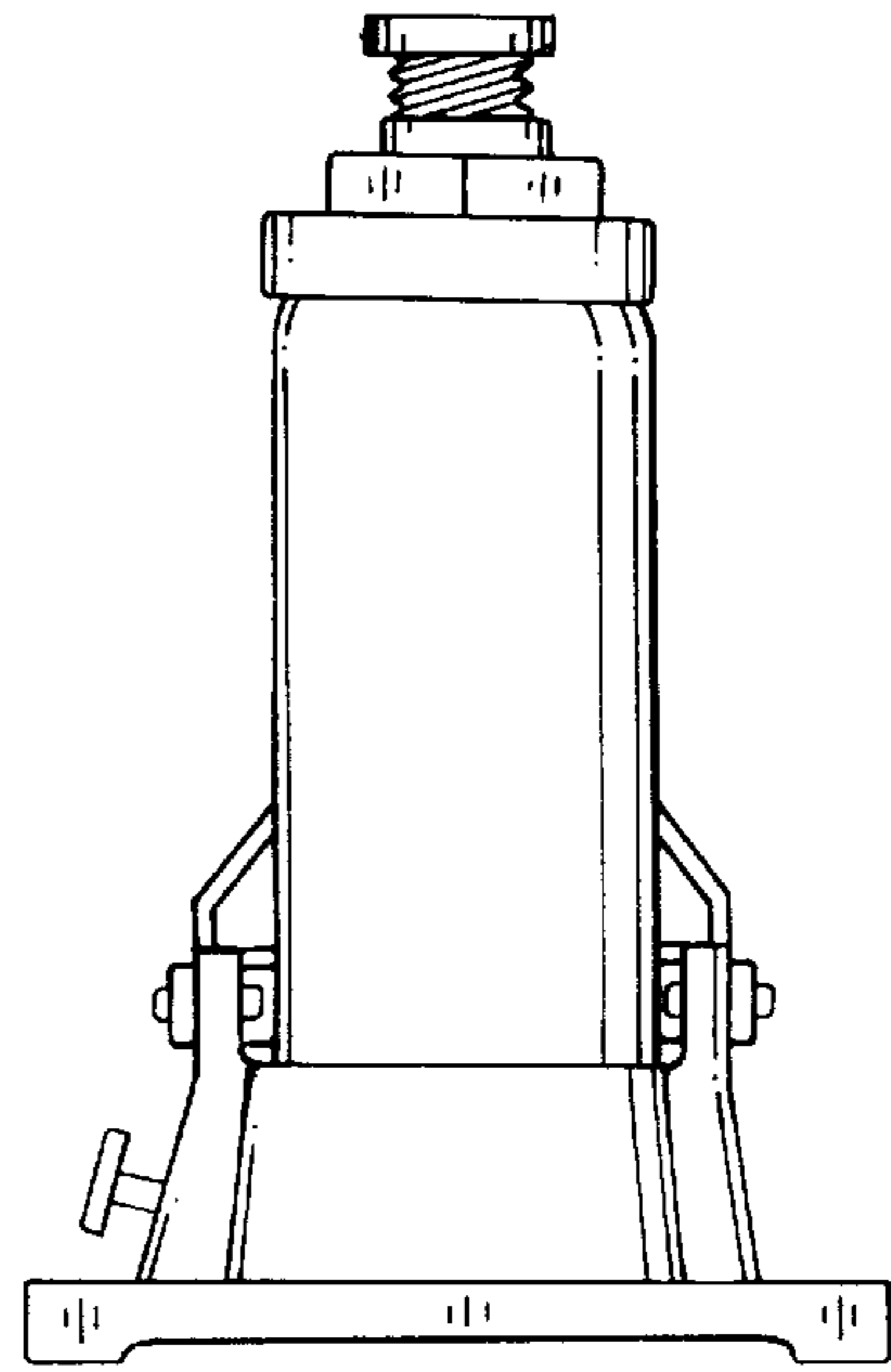

FIG. 3

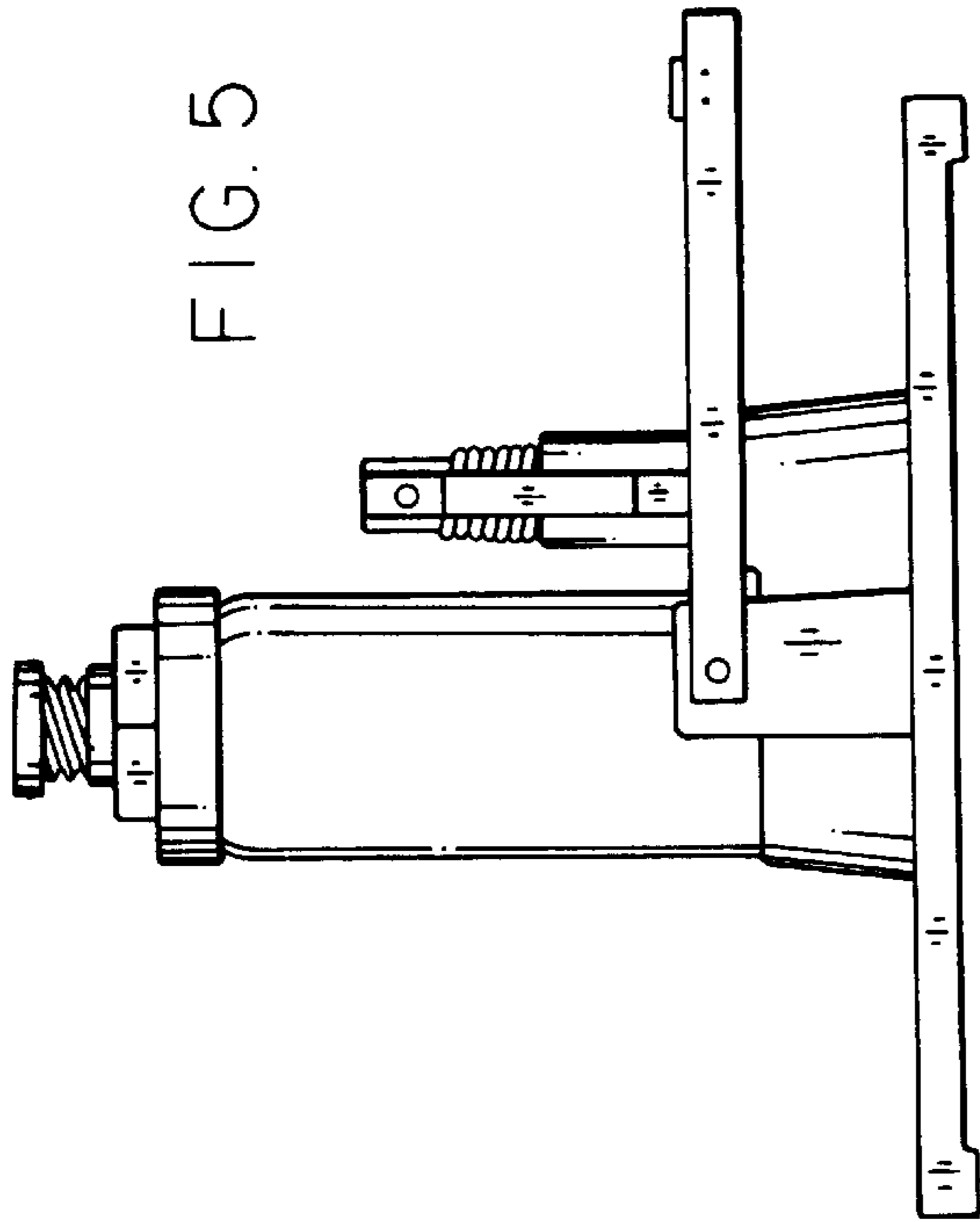

FIG. 5

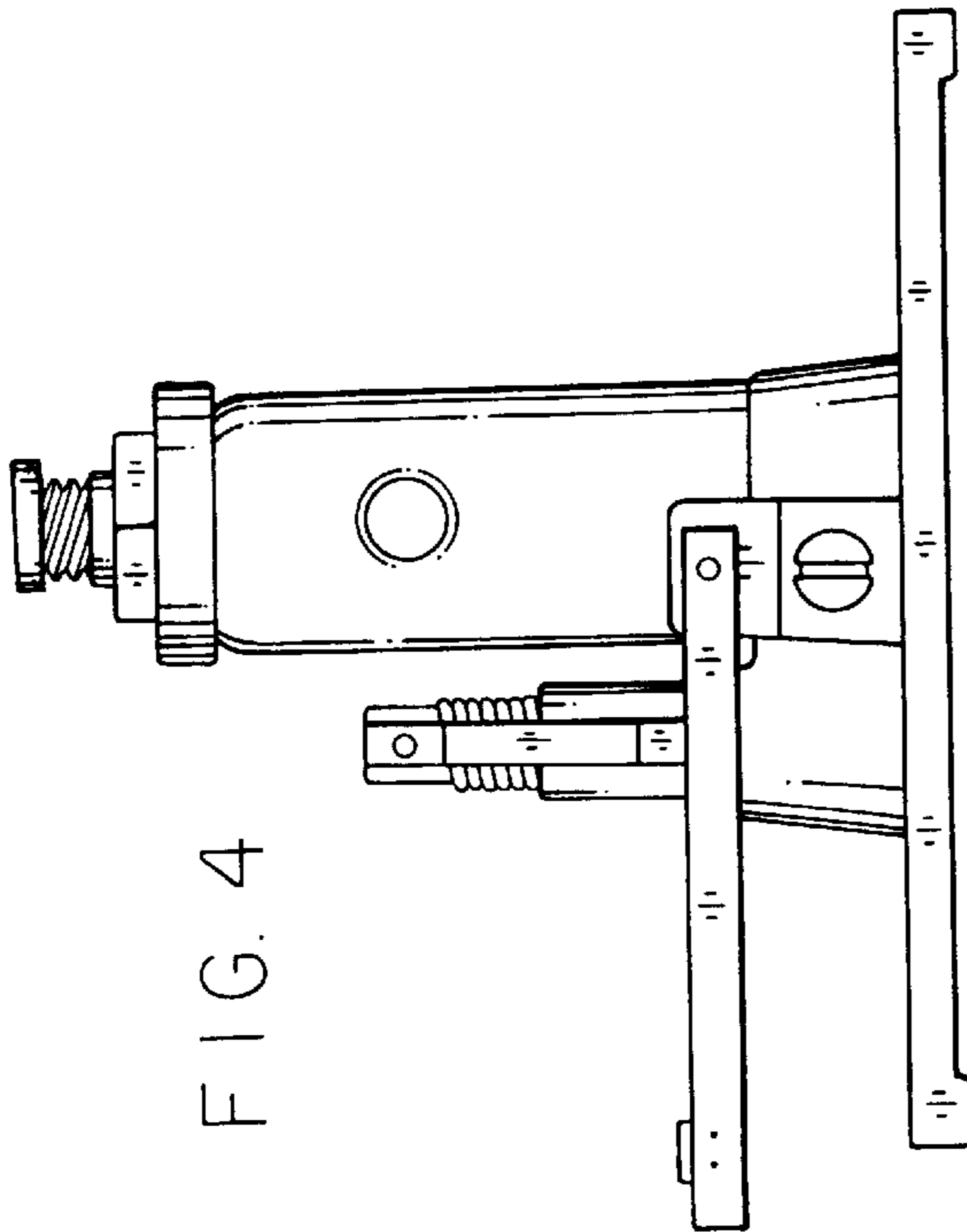

FIG. 4

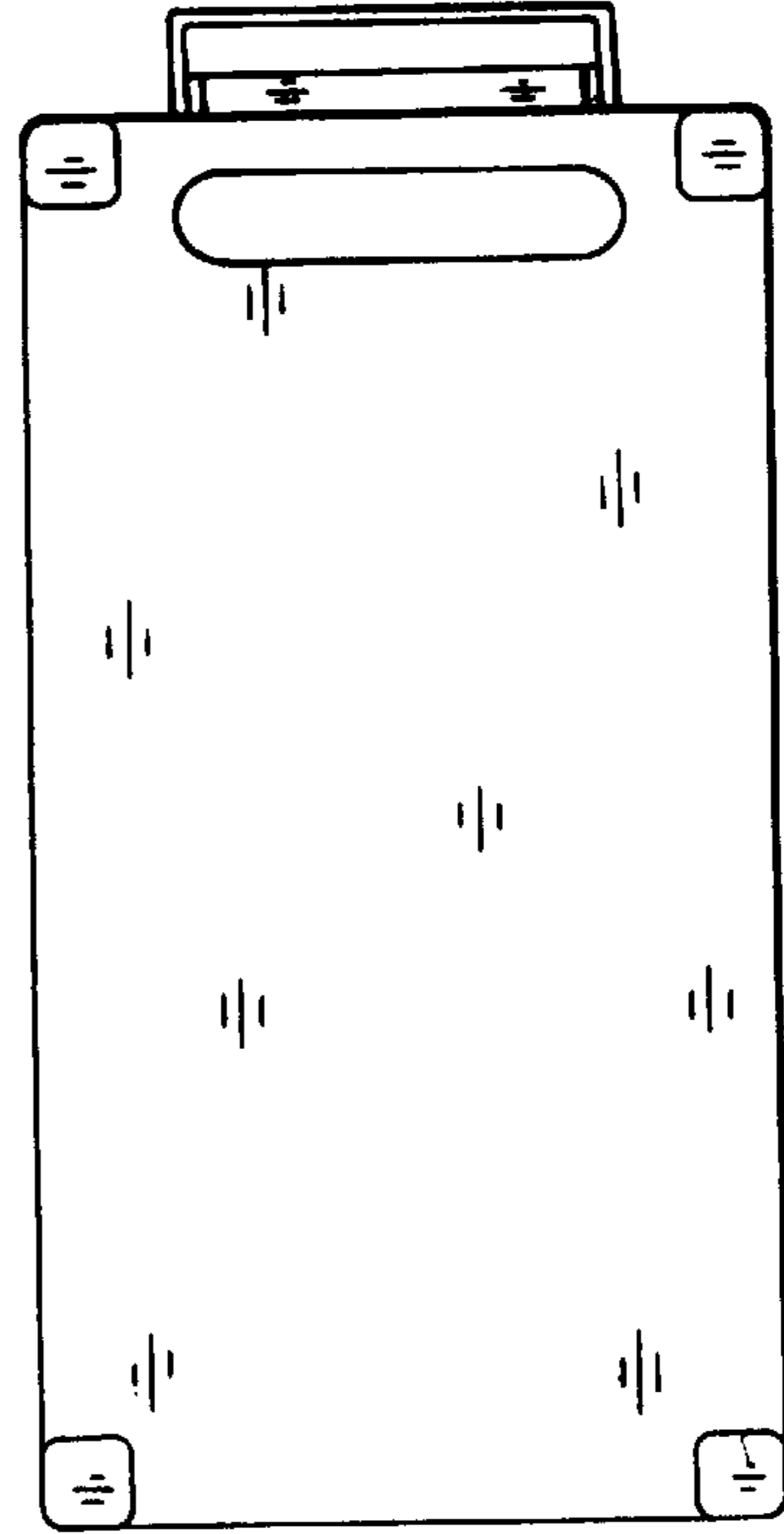

FIG. 7

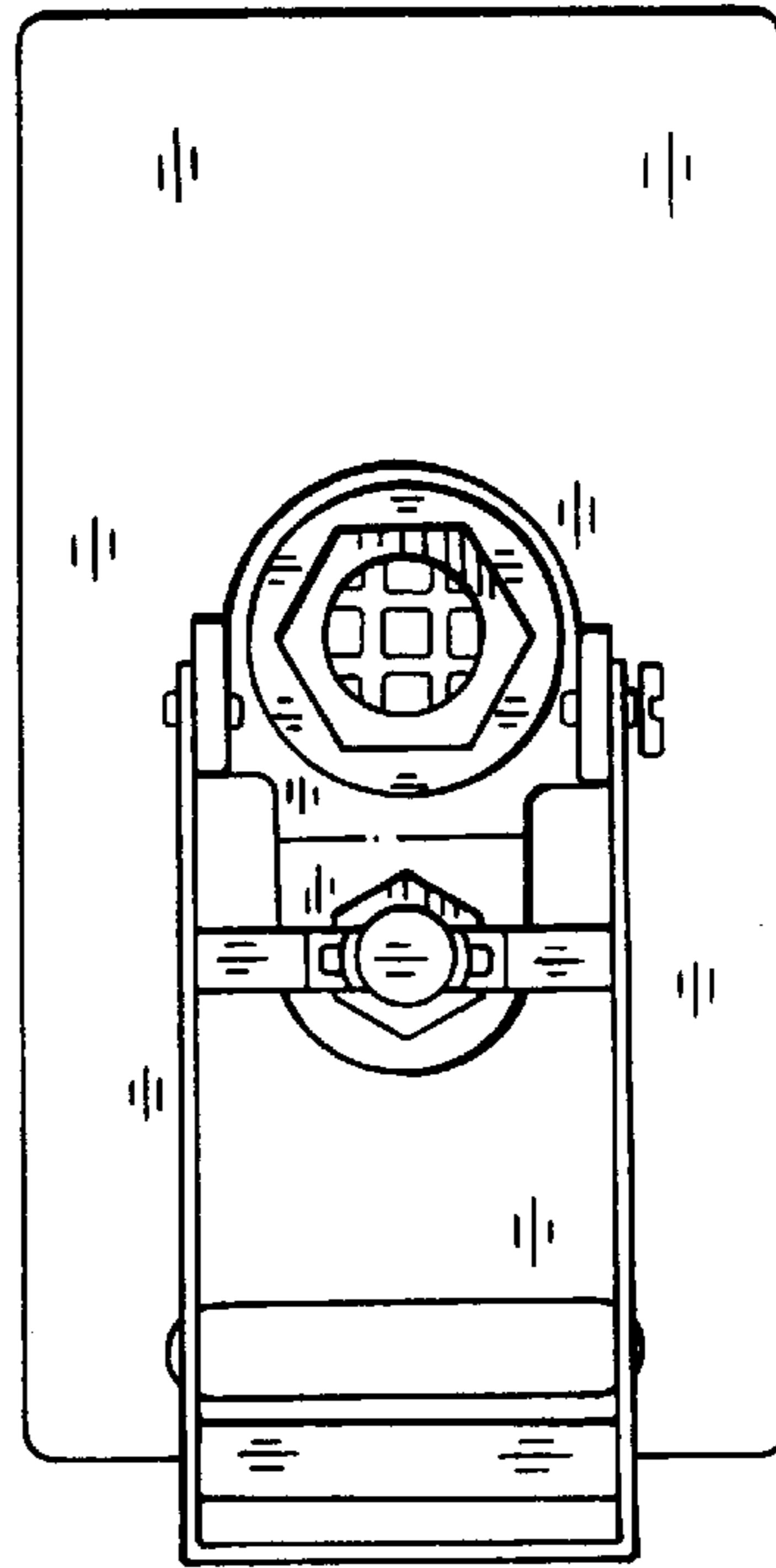

FIG. 6

FIG. 8

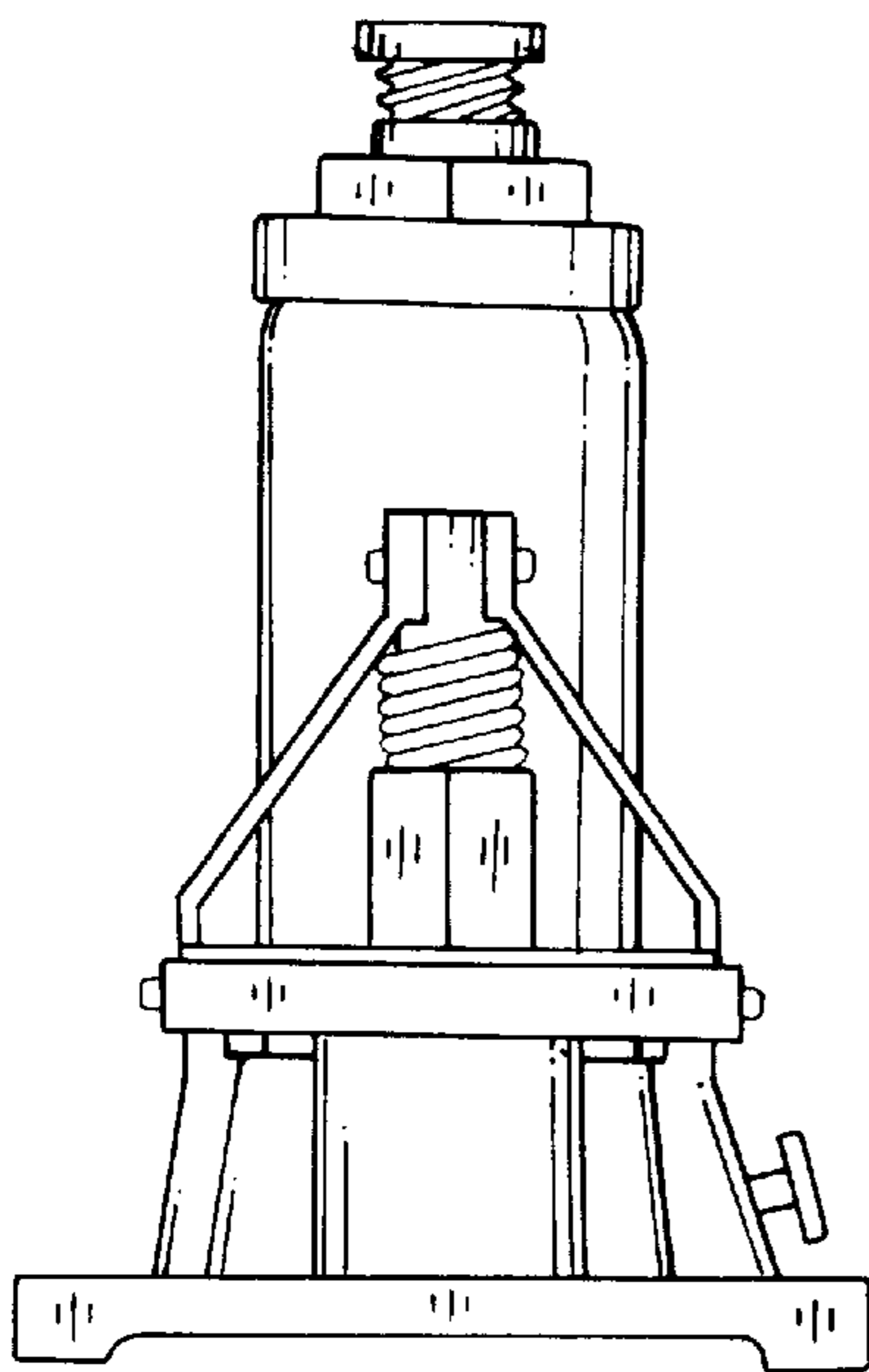
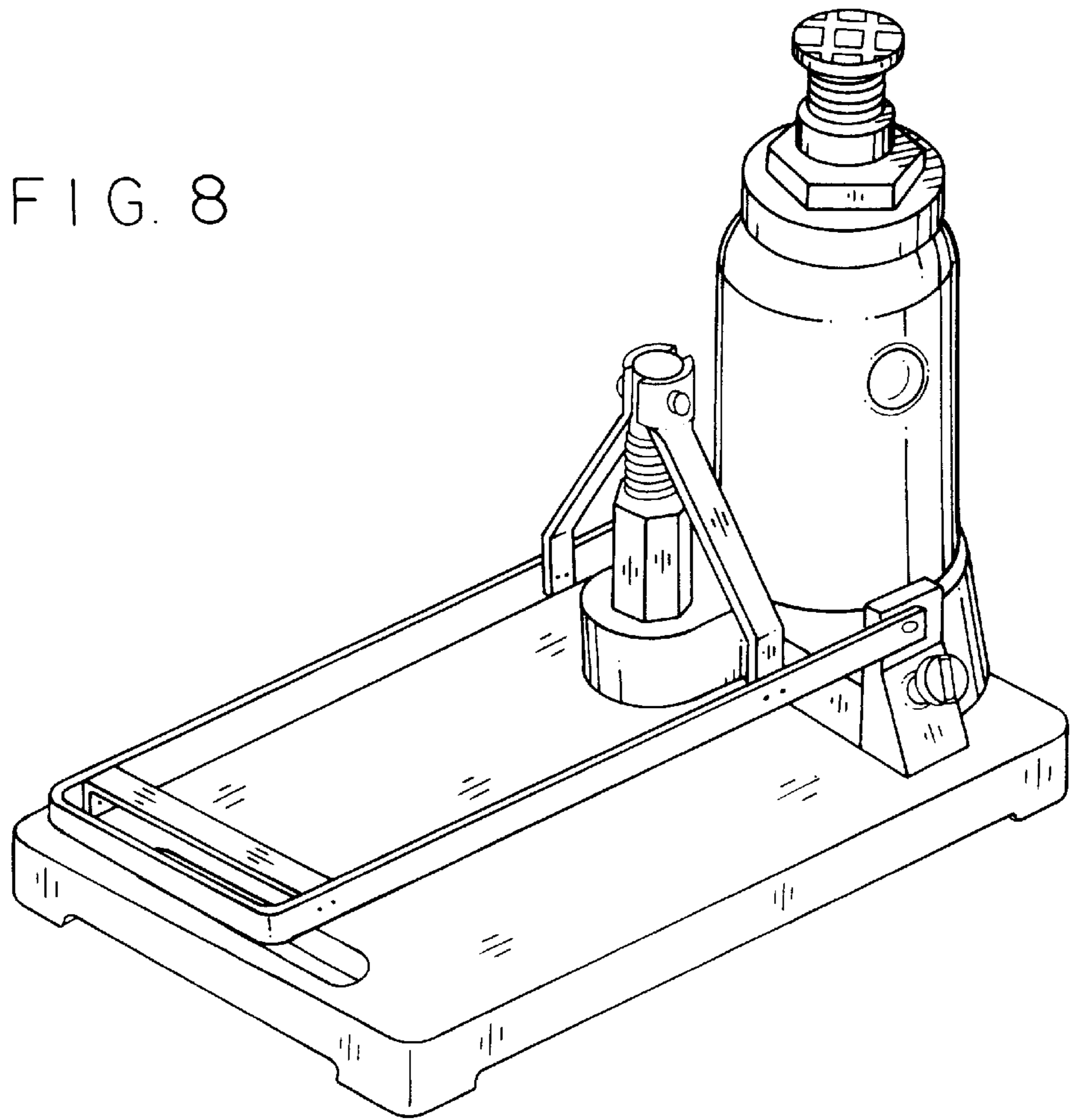

FIG. 9

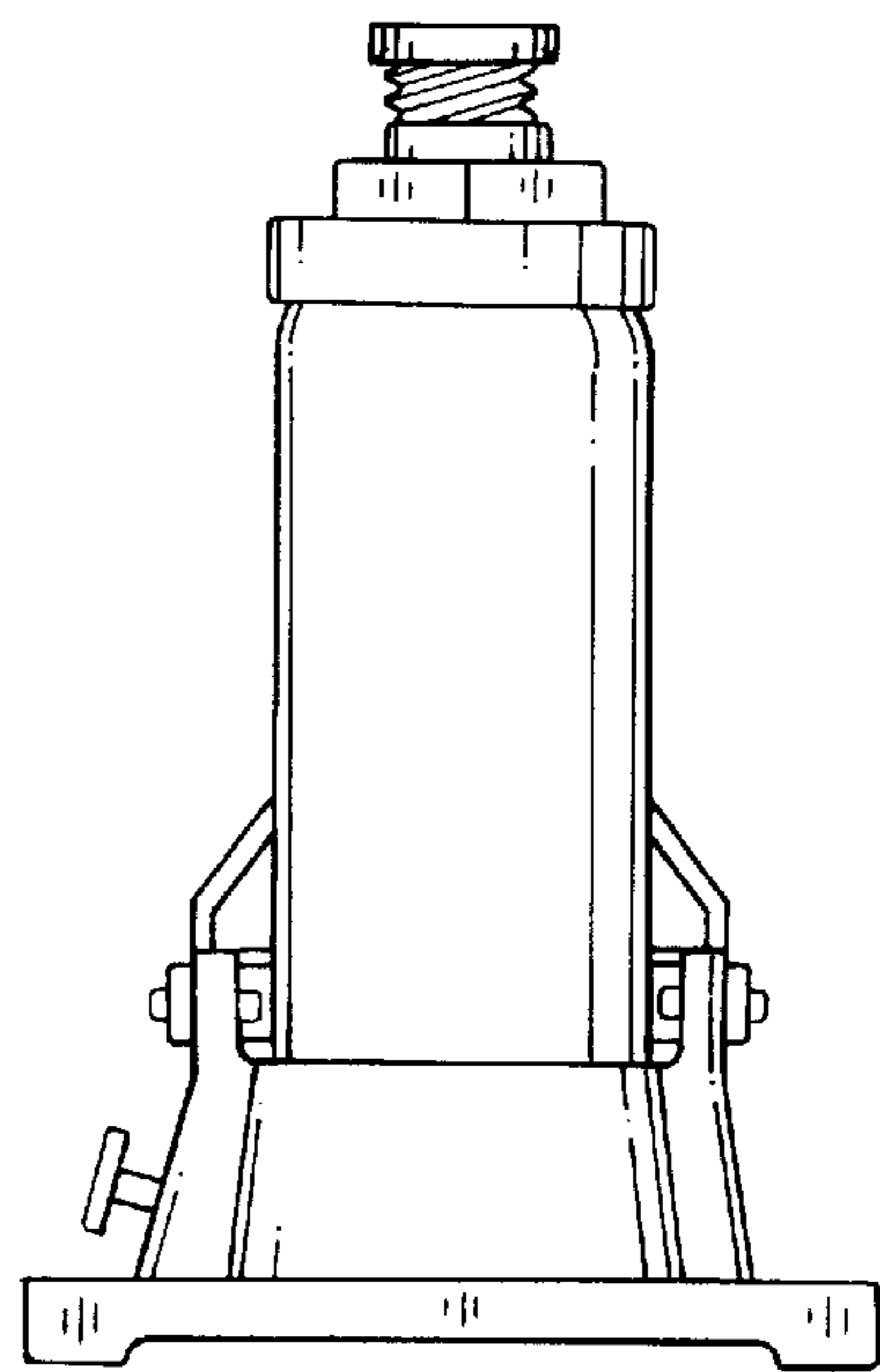

FIG. 10

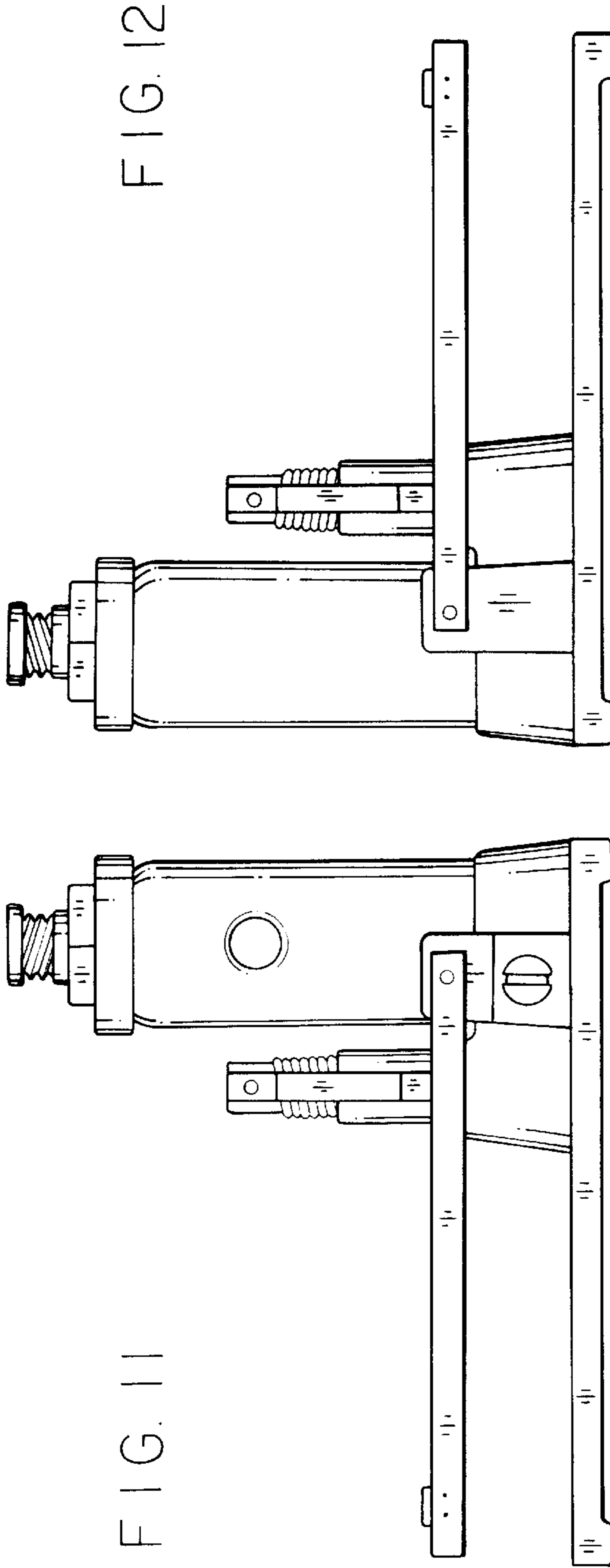

FIG. 12

FIG. 11

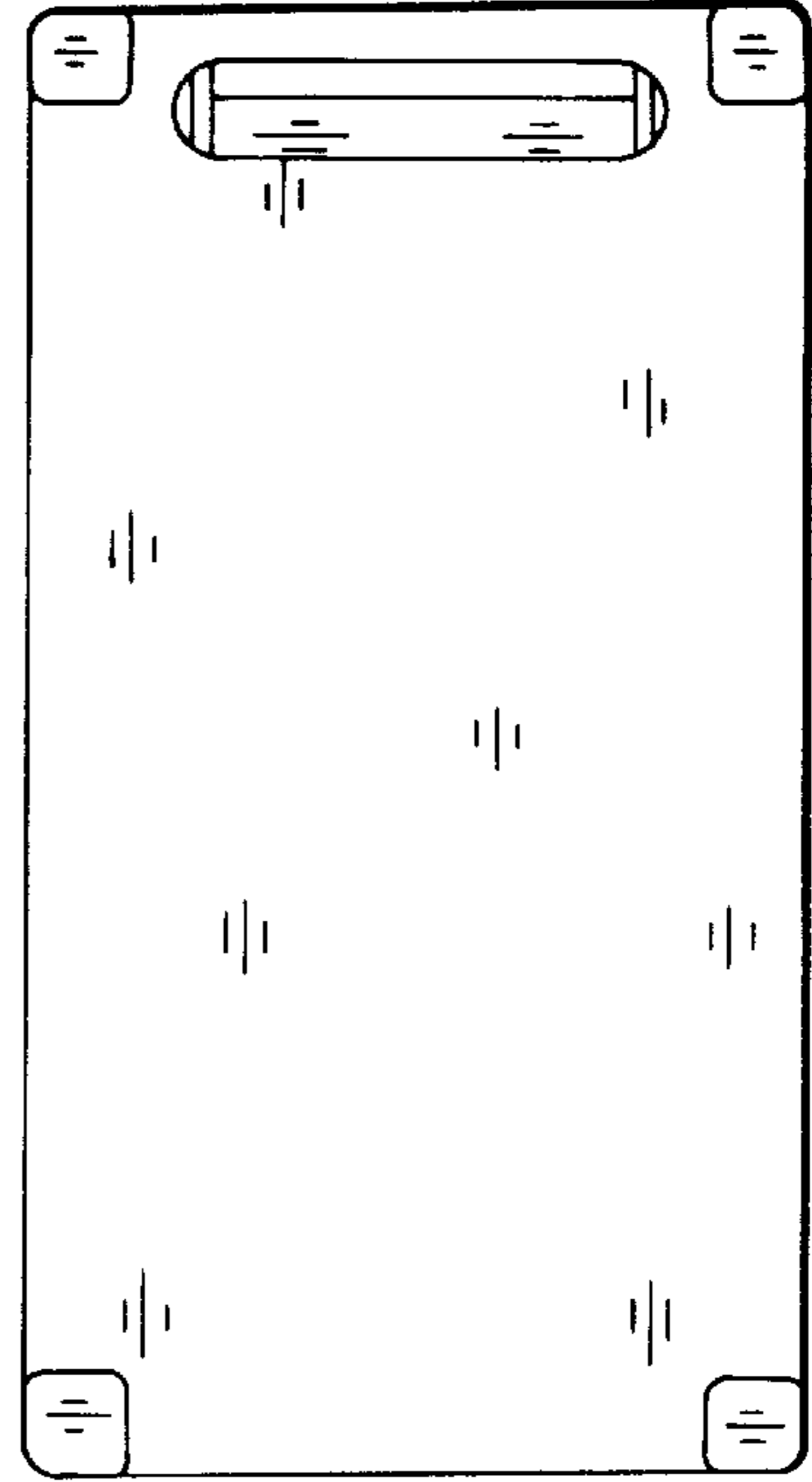

FIG. 14

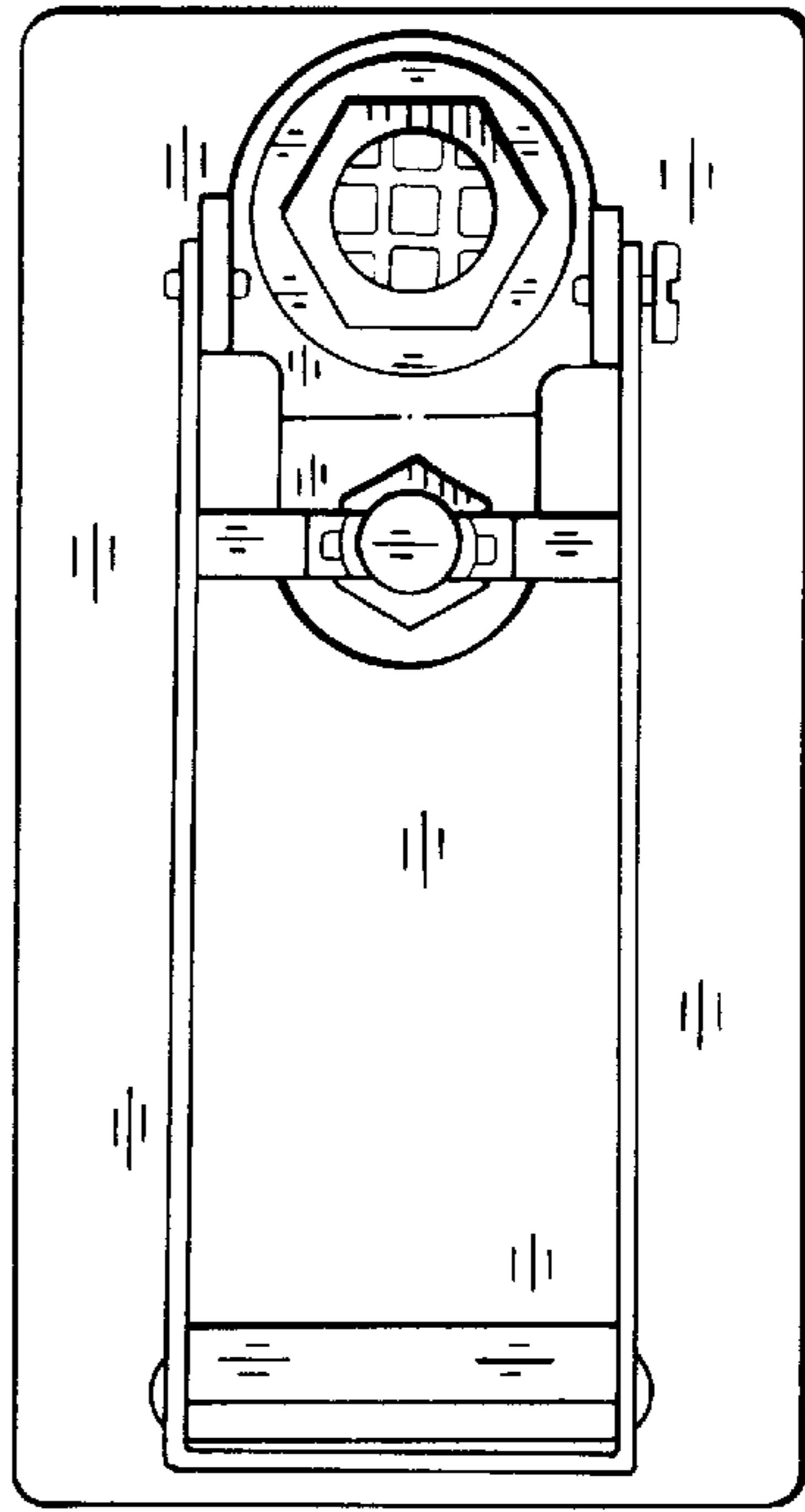

FIG. 13