



US00D426861S

# United States Patent [19]

[11] Patent Number: **Des. 426,861**

Jones, Jr. et al.

[45] Date of Patent: **\*\* Jun. 20, 2000**

[54] **ENGINE FOR CHILDREN'S RIDE-ON VEHICLE**

[75] Inventors: **John L. Jones, Jr.**, East Aurora;  
**William R. Howell**, Chaffee, both of N.Y.

[73] Assignee: **Mattel, Inc.**, El Segundo, Calif.

[\*\*] Term: **14 Years**

[21] Appl. No.: **29/100,141**

[22] Filed: **Feb. 5, 1999**

[51] **LOC (7) Cl.** ..... **21-01**

[52] **U.S. Cl.** ..... **D21/528; D21/433**

[58] **Field of Search** ..... **D21/528, 533, D21/548-560, 561, 562, 424-435; D15/3, 446/16, 93, 457, 463, 470, 471**

[56] **References Cited**

**U.S. PATENT DOCUMENTS**

D. 217,272	4/1970	Genin .....	D21/528
D. 252,148	6/1979	Schramm et al. ....	D15/3
D. 278,163	3/1985	Carignan et al. ....	D21/528
D. 299,666	1/1989	Harrod .	
D. 314,997	2/1991	Harrod .	
D. 328,317	7/1992	Harrod .	
D. 360,438	7/1995	Foster et al. ....	D21/528

D. 396,900	8/1998	Bro et al. .	
2,181,282	11/1939	Oster .	
3,671,785	6/1972	Fuchs et al. .	
4,889,516	12/1989	Auer et al. ....	446/470
5,314,371	5/1994	Kramer .	
5,366,402	11/1994	Rudell et al. .	

**OTHER PUBLICATIONS**

Paul's Model Art pp. 72, 73, 1995.  
Fisher-Price® Toyfair Catalog, cover and p. 93, 1997.

*Primary Examiner*—Raphael Barkai  
*Attorney, Agent, or Firm*—Kolisch, Hartwell, Dickinson, McCormack & Heuser

[57] **CLAIM**

The ornamental design for an engine for children's ride-on vehicle, as shown and described.

**DESCRIPTION**

FIG. 1 is a perspective view of an engine for a children's ride-on vehicle, the portions depicted in dashed lines forming no part of the claimed design;  
FIG. 2 is a top plan view thereof;  
FIG. 3 is a right-side elevation view thereof;  
FIG. 4 is a left-side elevation view thereof;  
FIG. 5 is a front elevation view thereof; and,  
FIG. 6 is a rear elevation view thereof.

**1 Claim, 3 Drawing Sheets**

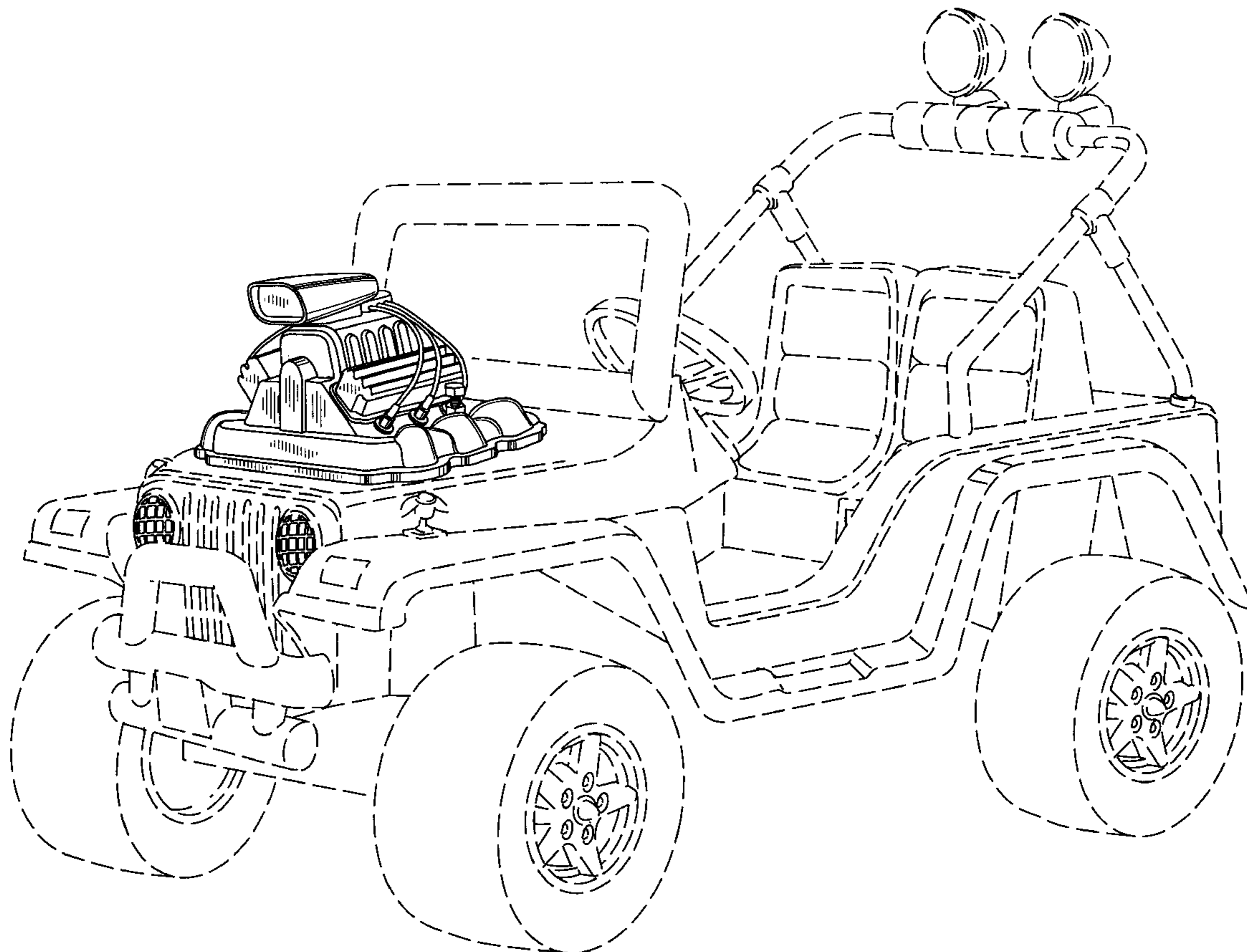

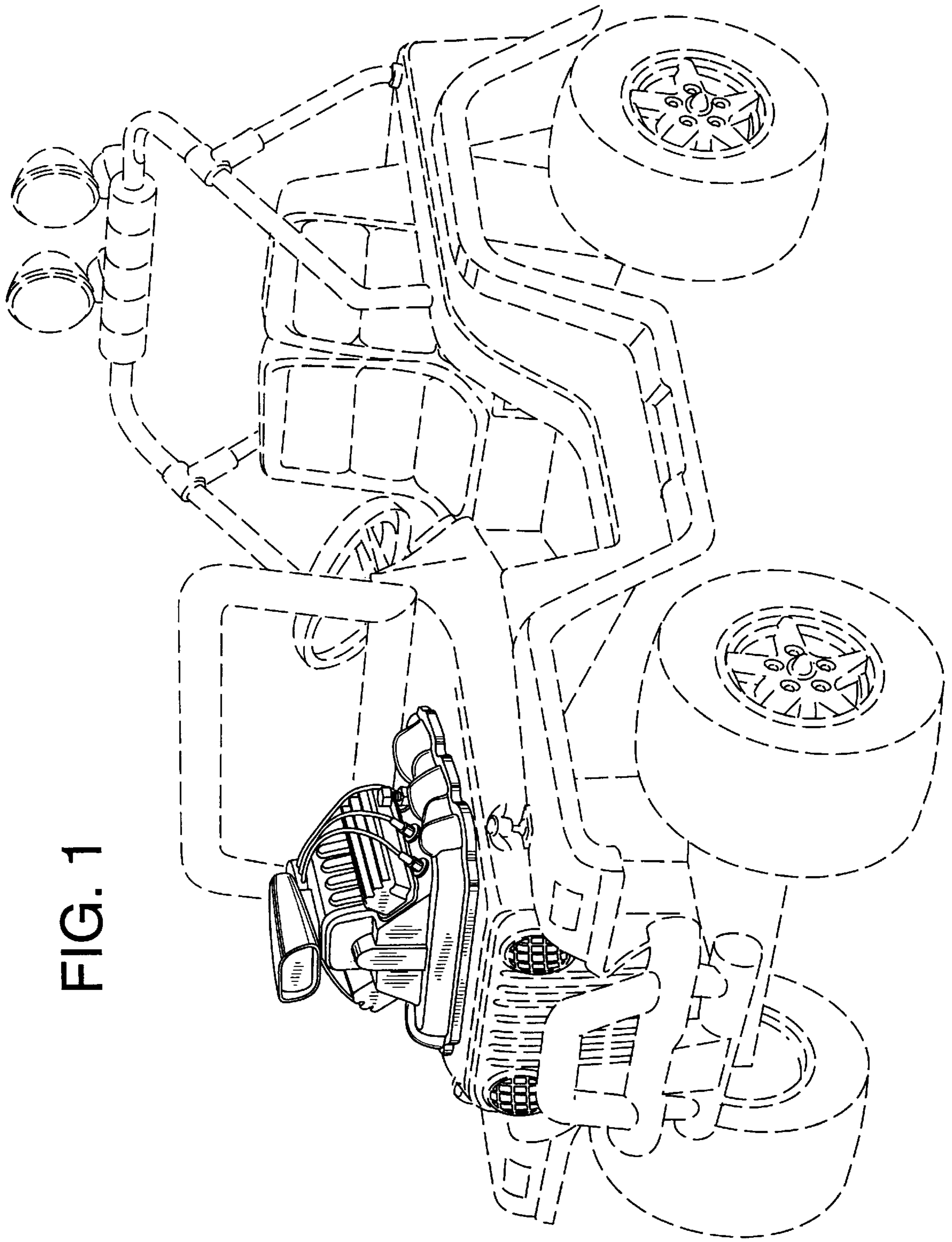

FIG. 1

FIG. 2

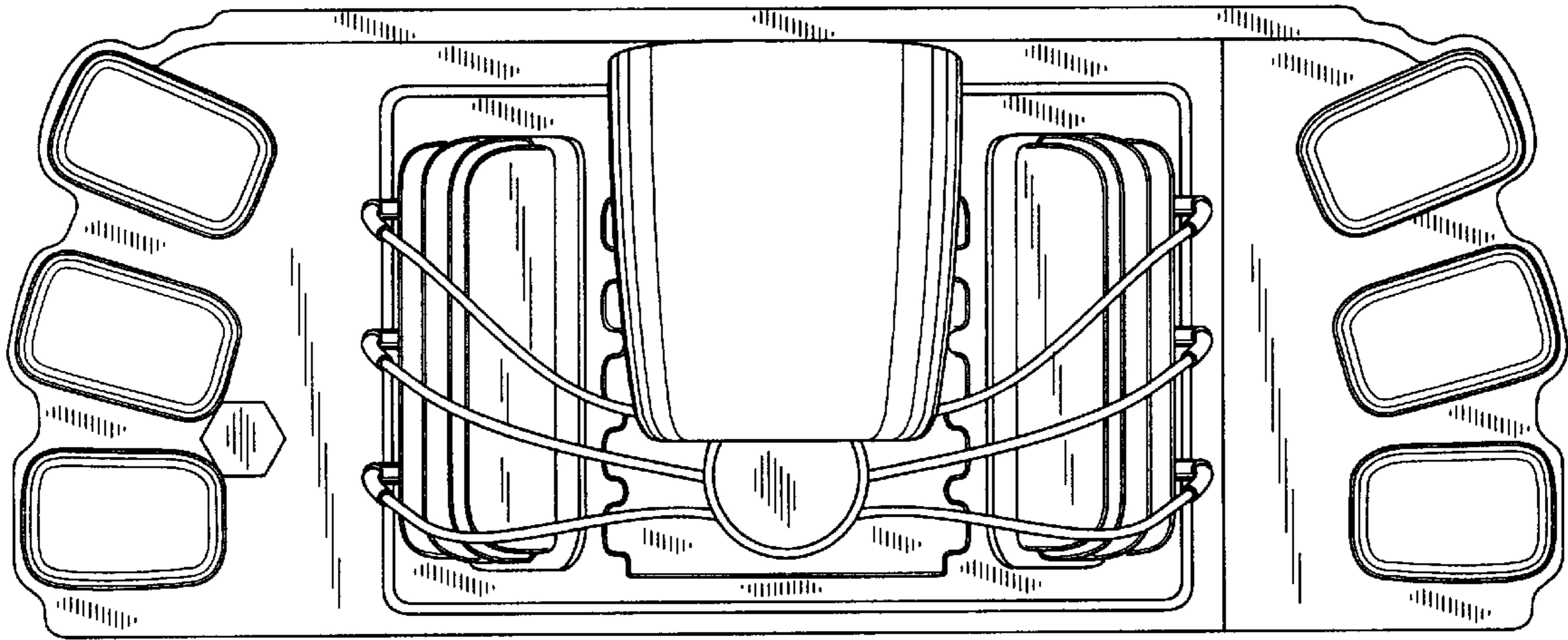

FIG. 3

FIG. 4

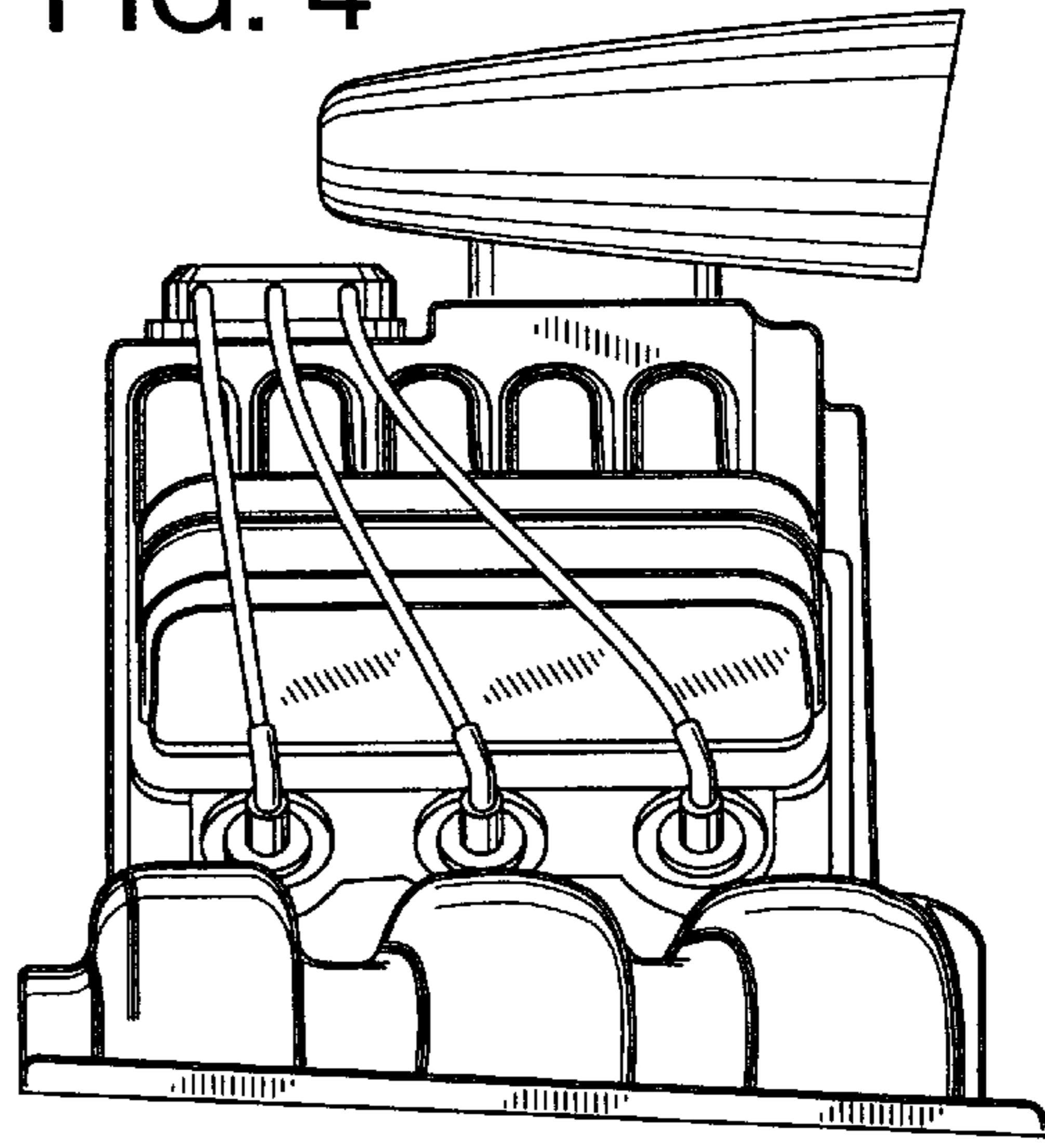
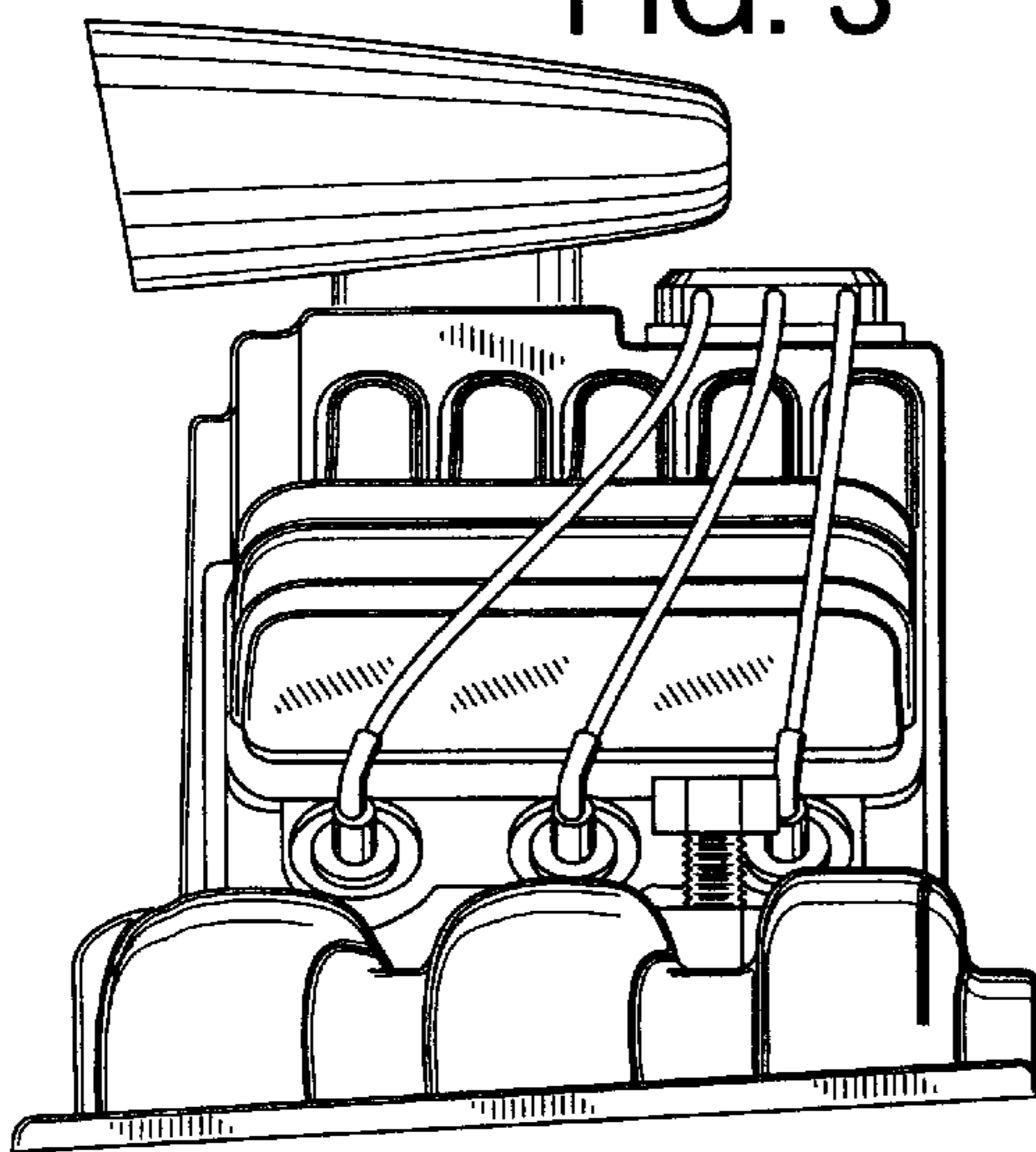



FIG. 5

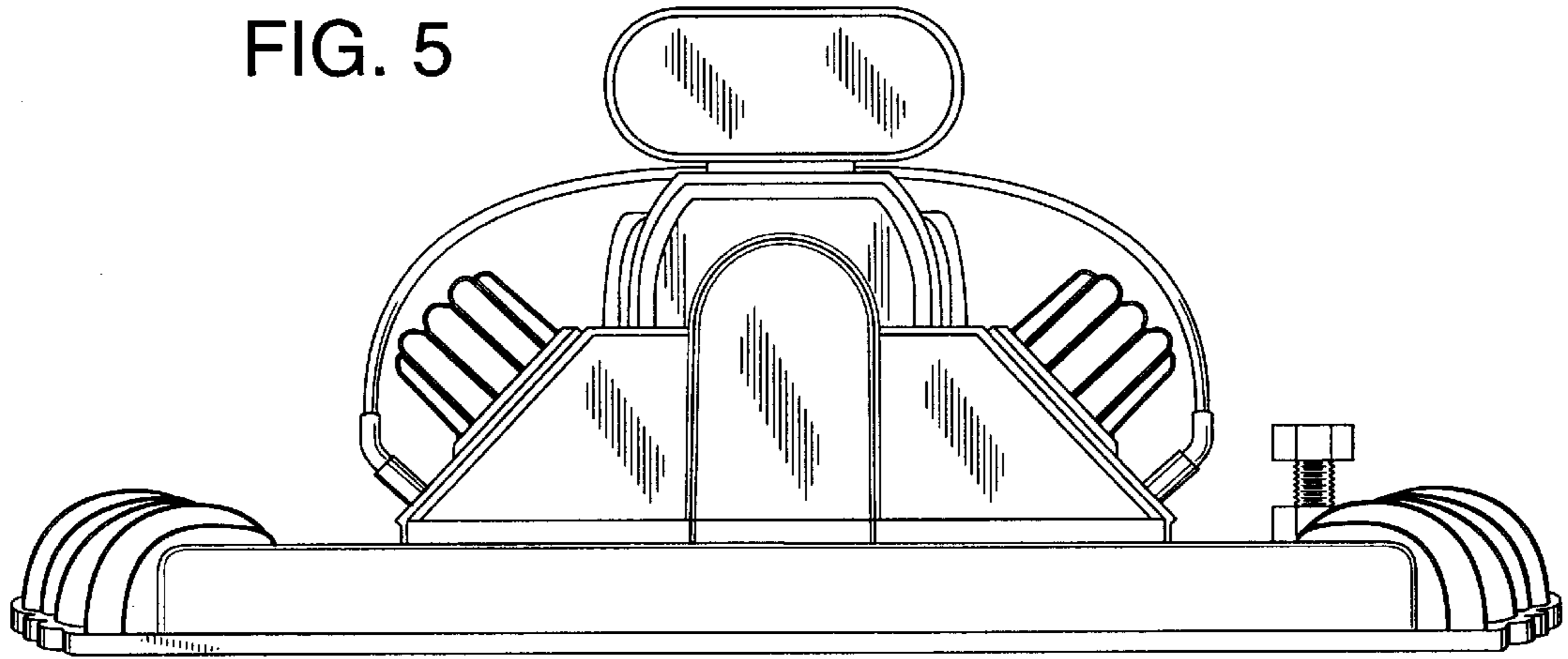

FIG. 6

