



US00D426860S

United States Patent [19]

[11] **Patent Number: Des. 426,860**

Ho

[45] **Date of Patent: ** Jun. 20, 2000**

[54] **MAGNIFYING GLASS FOR HANDHELD ELECTRONIC GAMES**

[75] Inventor: **Kin-Chung Ho**, Kowloon, The Hong Kong Special Administrative Region of the People's Republic of China

[73] Assignee: **Storm Electronics Company Limited**, Kowloon, The Hong Kong Special Administrative Region of the People's Republic of China

[**] Term: **14 Years**

[21] Appl. No.: **29/109,071**

[22] Filed: **Aug. 9, 1999**

[30] **Foreign Application Priority Data**

Jun. 5, 1999 [HK] The Hong Kong Special Administrative Region of the People's Republic of China 9910685.2M002

[51] **LOC (7) Cl.** **21-01**

[52] **U.S. Cl.** **D21/333; D26/24**

[58] **Field of Search** D21/324, 328, D21/329, 330, 333, 385; 273/148 B; 463/1, 30-35, 46, 47; 363/23, 28, 84, 85, 109, 191, 253, 455, 806; 248/917, 918; D26/23, 24, 26, 37, 52, 51

[56] **References Cited**

U.S. PATENT DOCUMENTS

D. 316,454 4/1991 Tortola et al. D26/24

D. 341,855 11/1993 Tortola et al. D21/385
4,589,659 5/1986 Yokoi et al. 463/1
4,756,528 7/1988 Umashankar et al. 463/1
5,130,907 7/1992 Tortola et al. 273/148 B
5,165,779 11/1992 Torloal et al. 362/109
5,217,295 6/1993 Tortola et al. 362/109
5,325,280 6/1994 Tortola et al. 362/109 X

Primary Examiner—Prabhakar Deshmukh
Attorney, Agent, or Firm—Alix, Yale, & Ristas, LLP

[57] **CLAIM**

The ornamental design for a magnifying glass for handheld electronic games, as shown and described.

DESCRIPTION

FIG. 1 is a perspective view of the magnifying glass for handheld electronic games;
FIG. 2 is a perspective view of the magnifying glass for handheld electronic games of FIG. 1 for a collapsed configuration thereof;
FIG. 3 is a front elevation view of the magnifying glass for handheld electronic games of FIG. 1;
FIG. 4 is a rear elevation view of the magnifying glass for handheld electronic games of FIG. 1;
FIG. 5 is a left side elevation view of the magnifying glass for handheld electronic games if FIG. 1;
FIG. 6 is a right side elevation view of the magnifying glass for handheld electronic games of FIG. 1;
FIG. 7 is a top plan view of the magnifying glass for handheld electronic games of FIG. 1; and,
FIG. 8 is a bottom plan view of the magnifying glass for handheld electronic games.

1 Claim, 5 Drawing Sheets

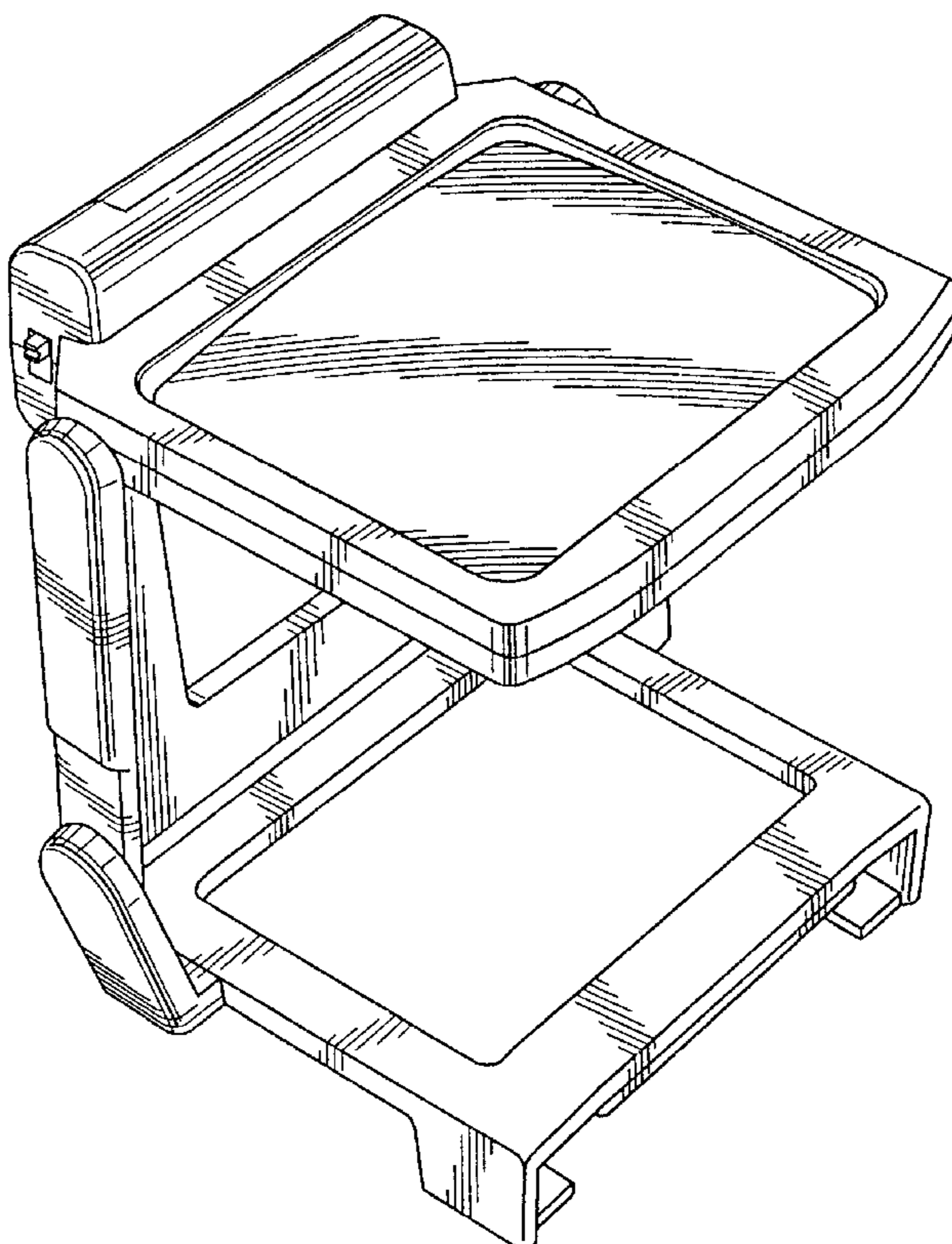

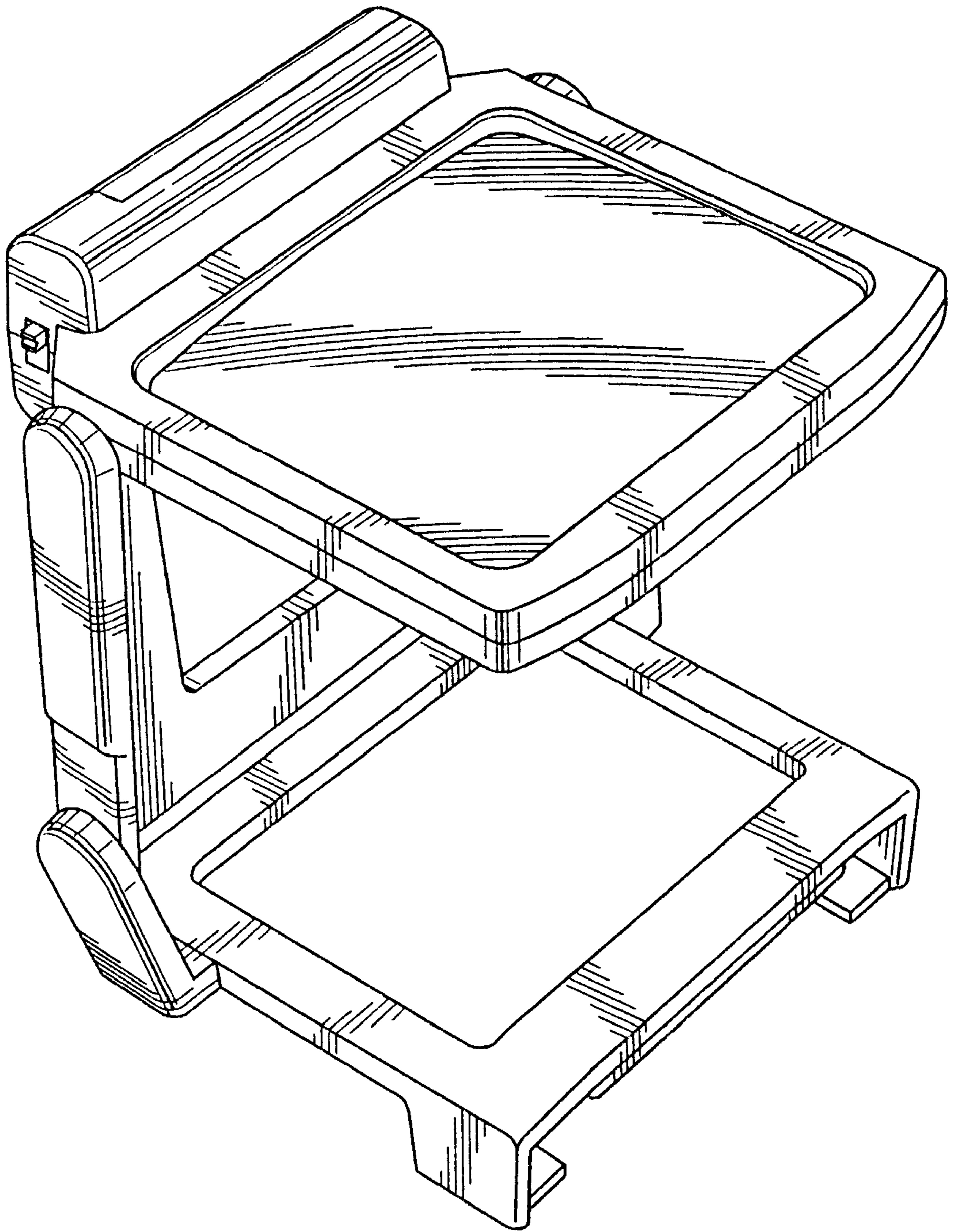

FIG. 1

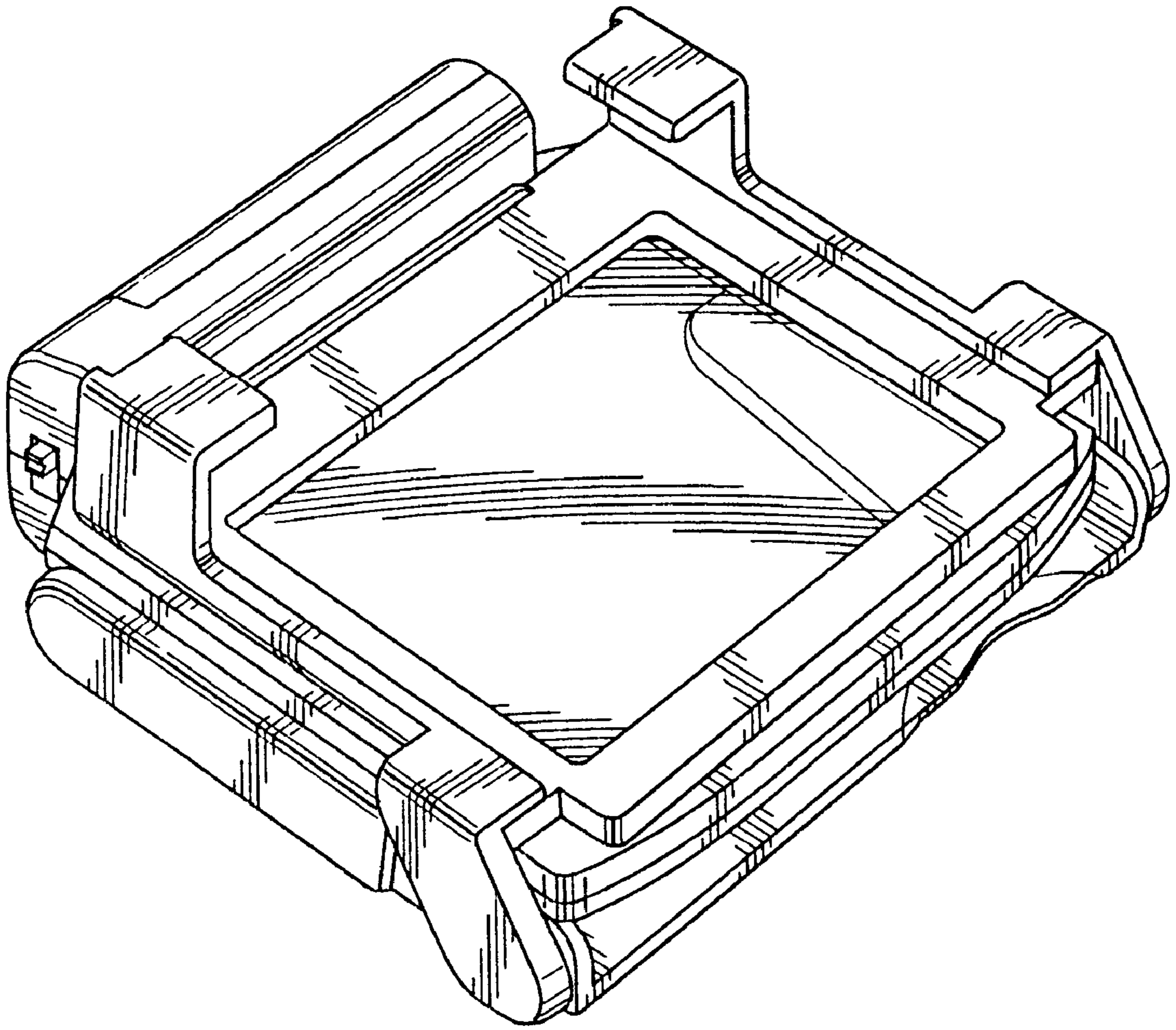

FIG. 2

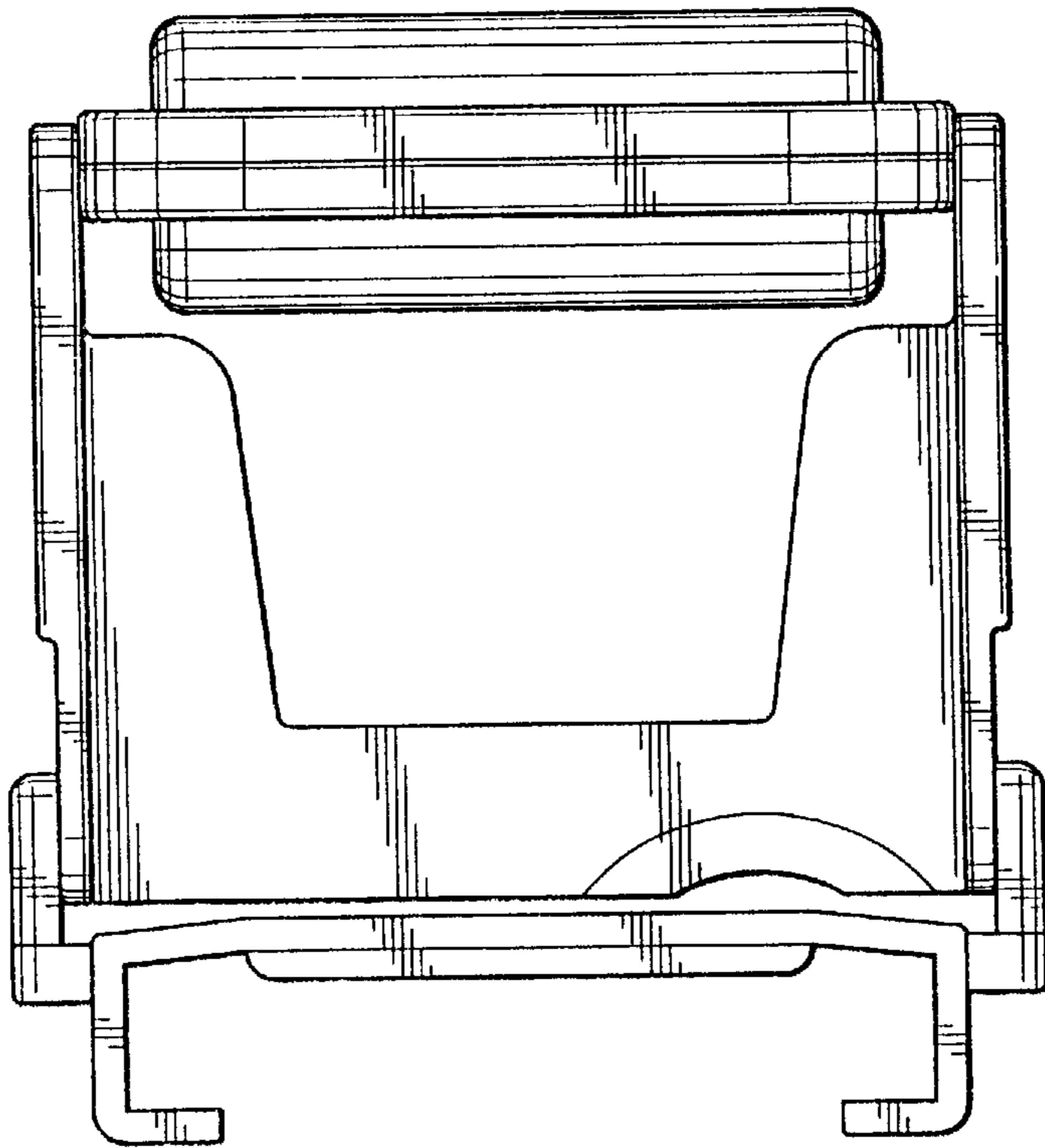

FIG. 3

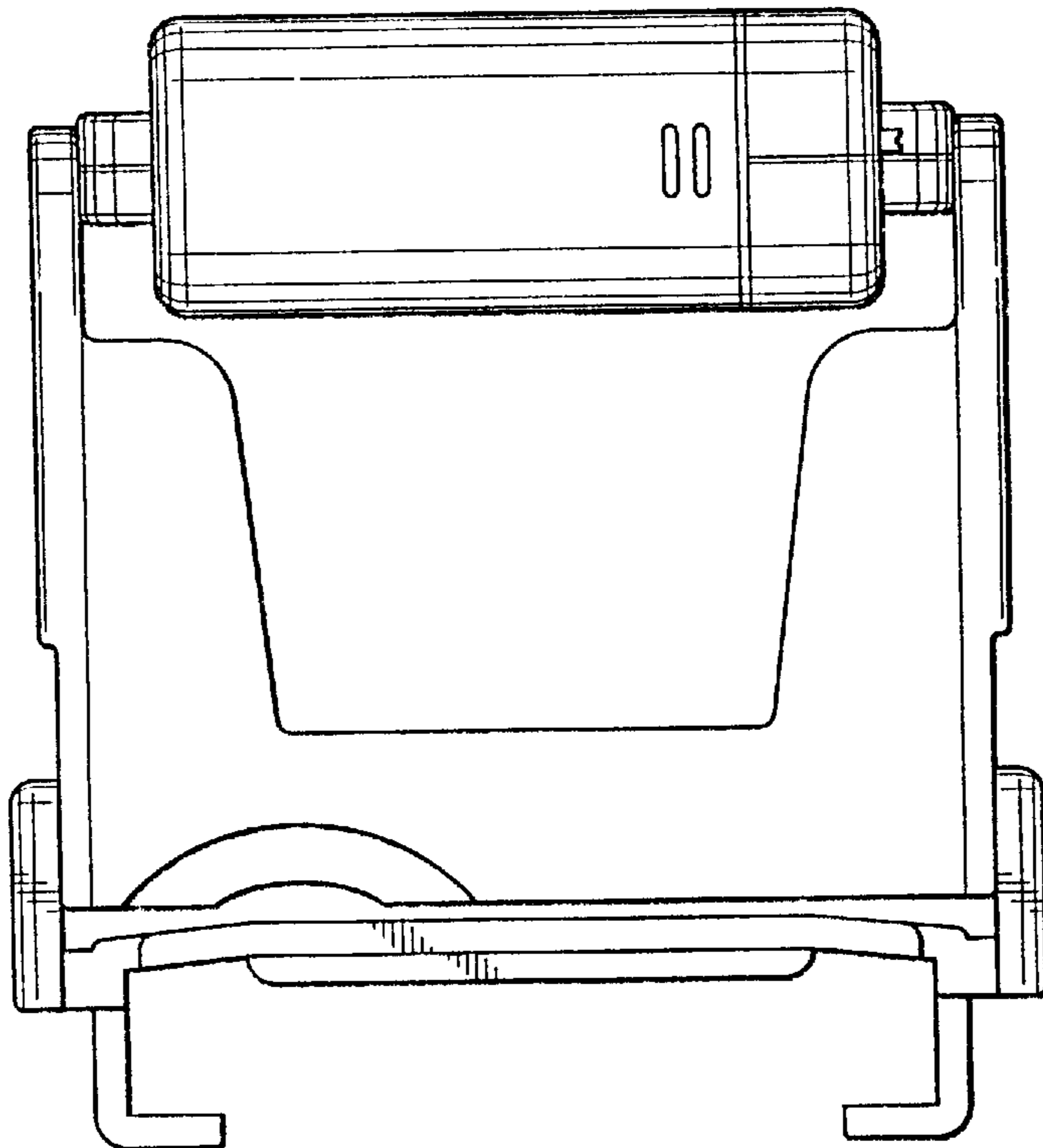

FIG. 4

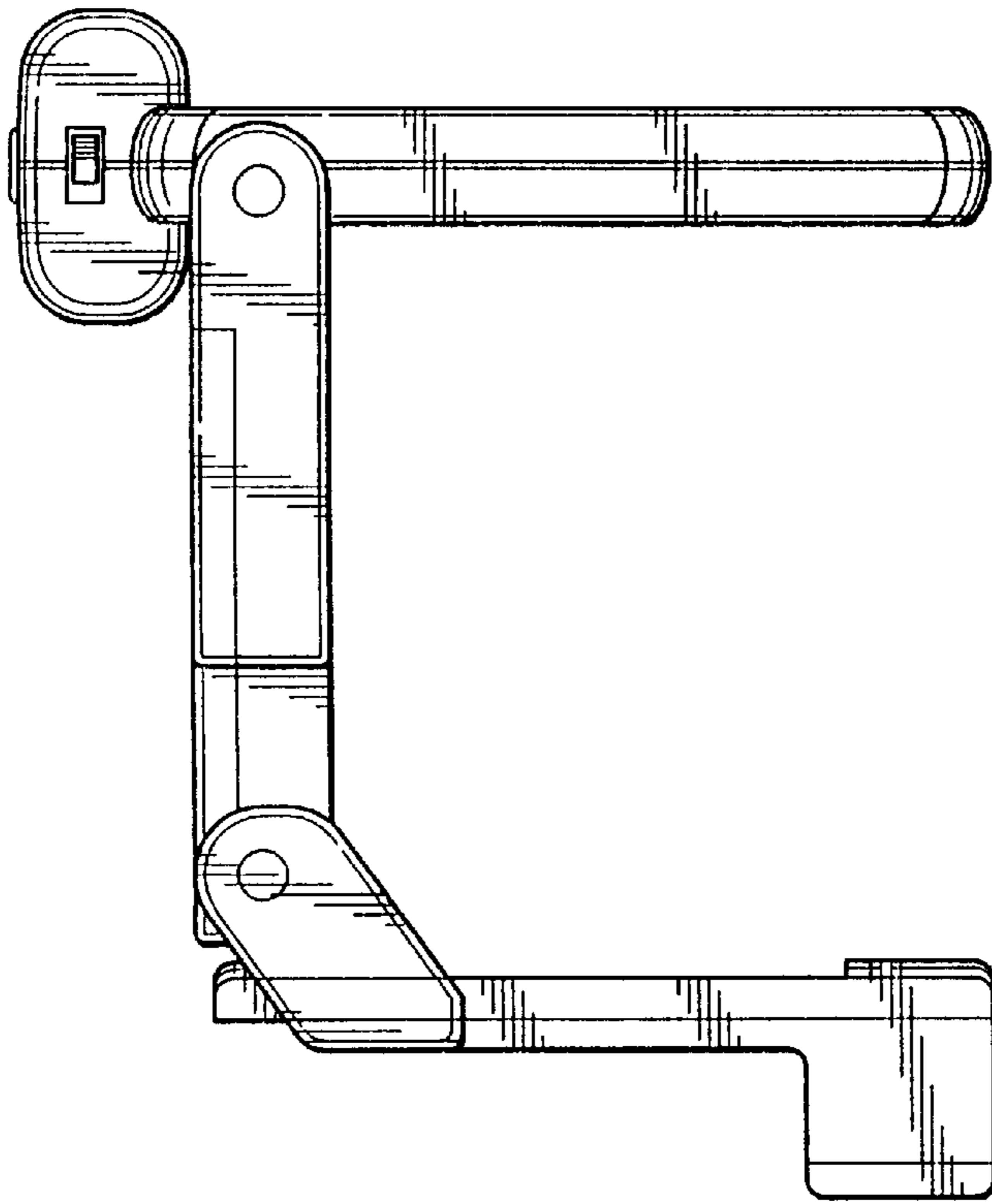

FIG. 5

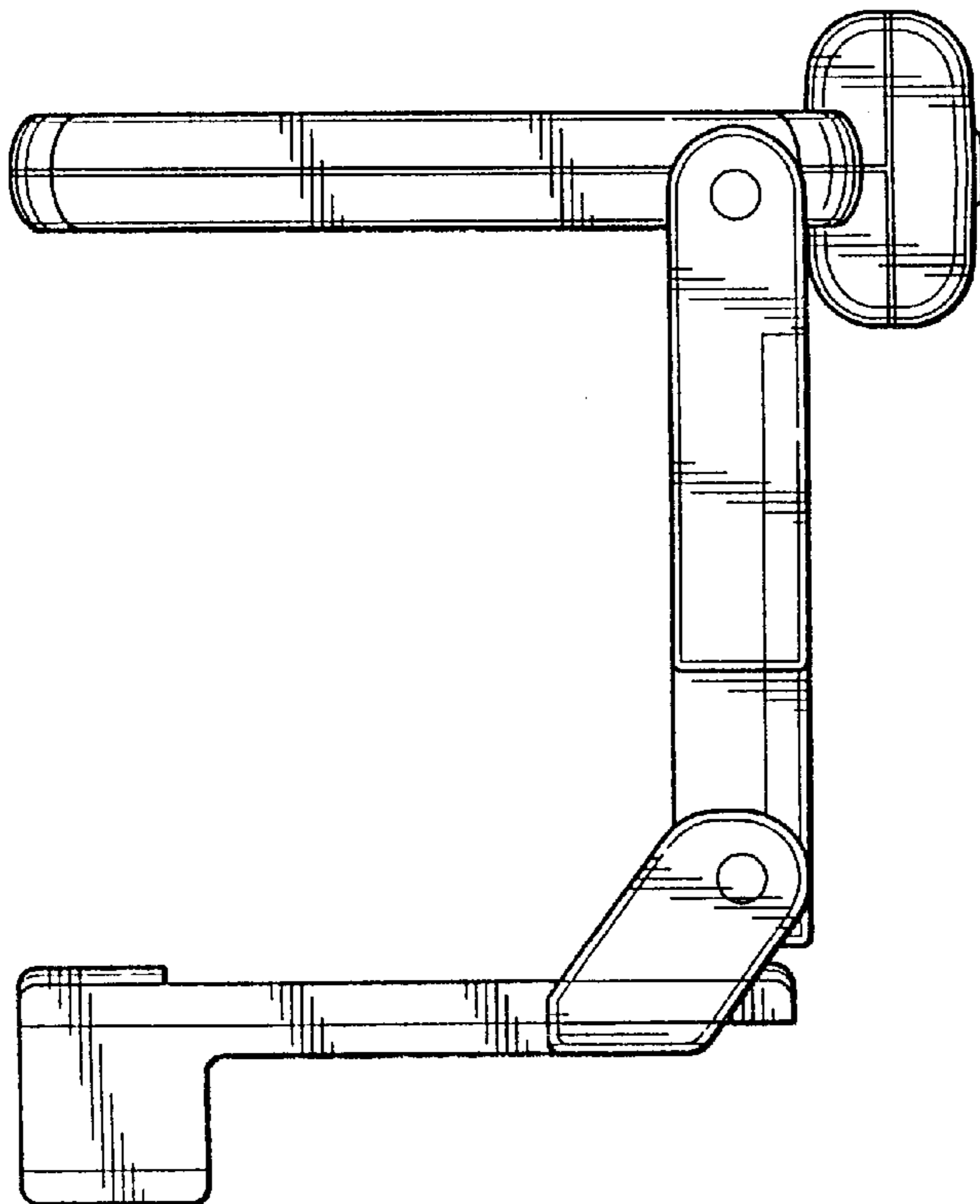

FIG. 6

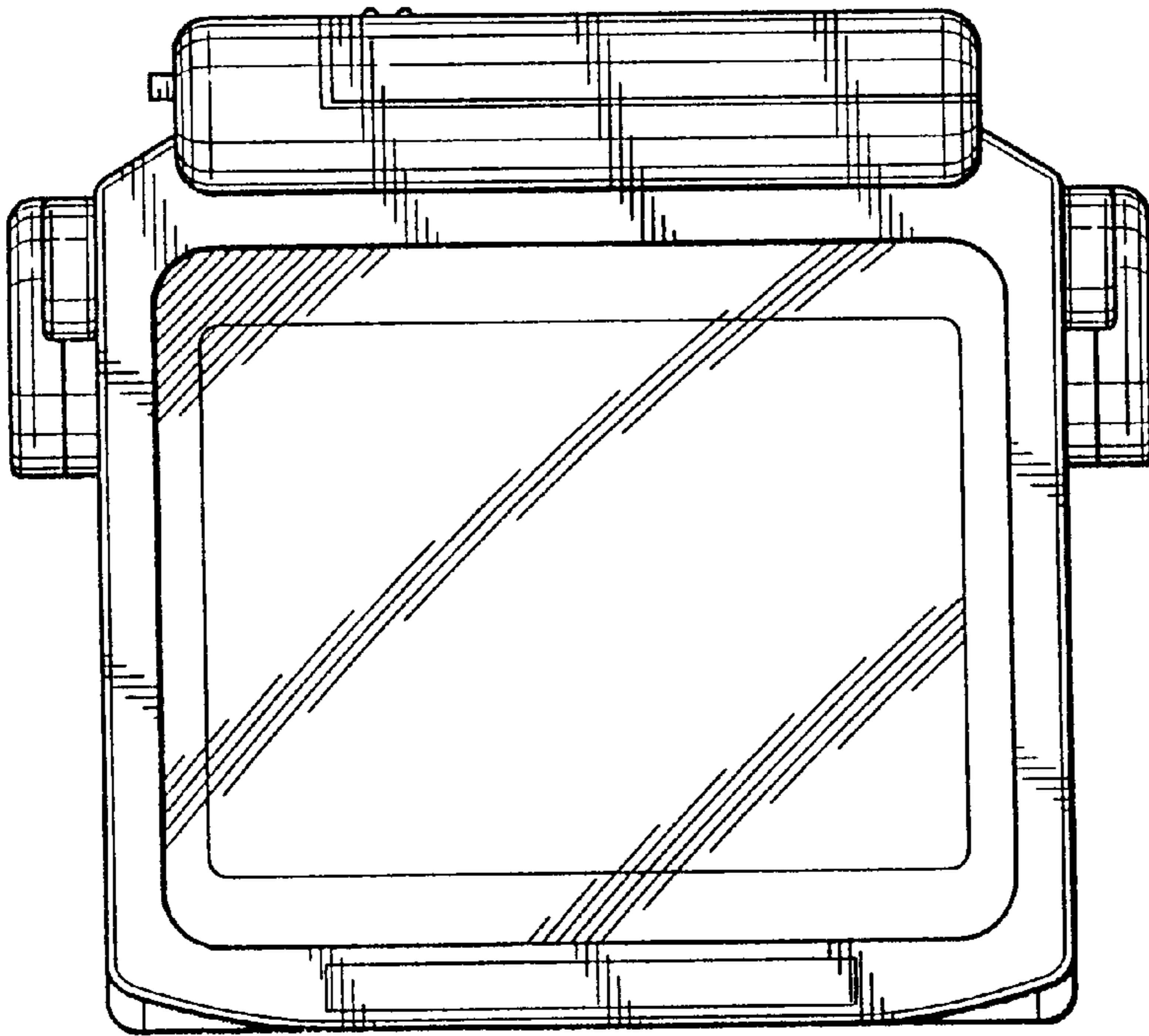

FIG. 7

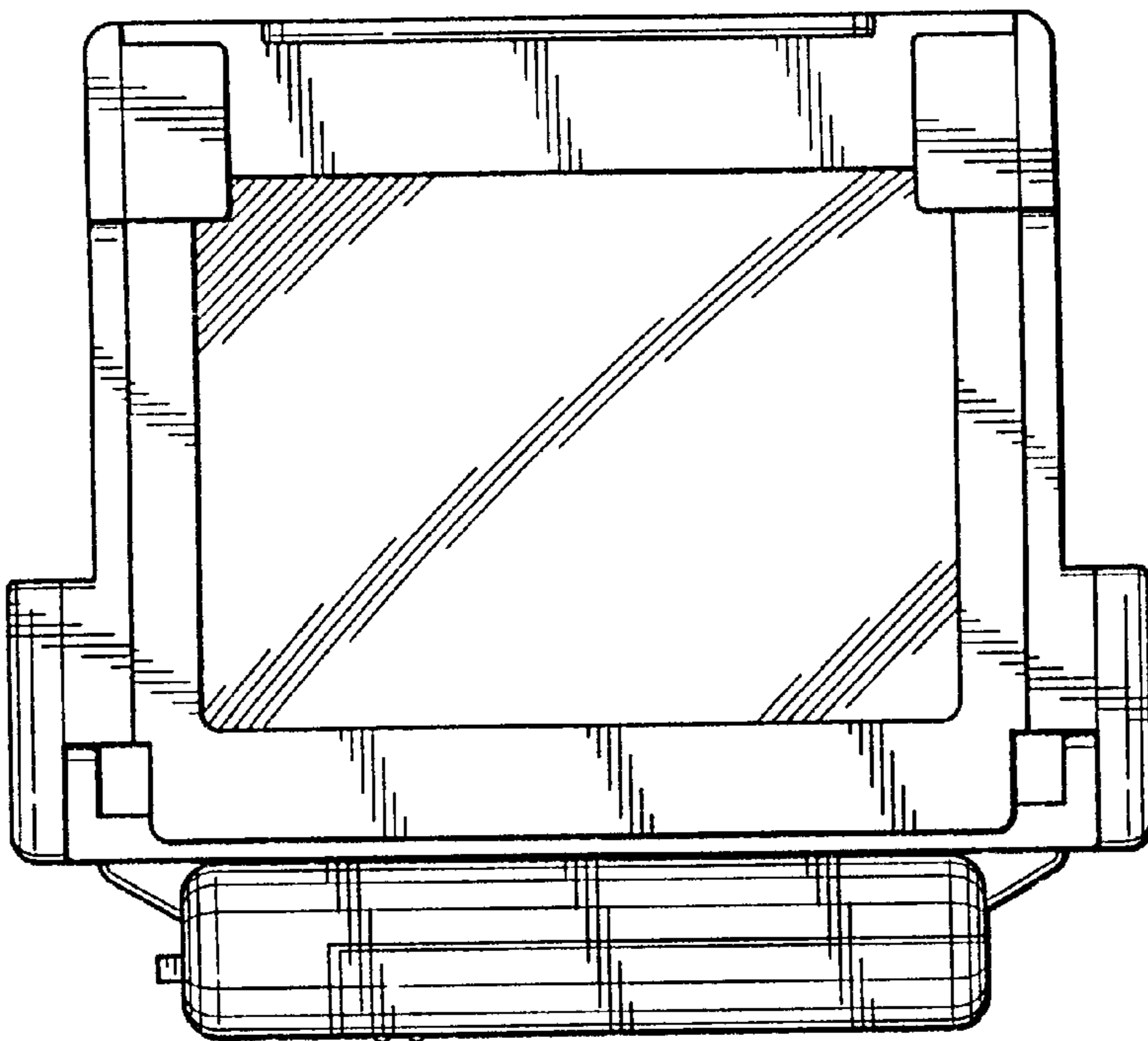

FIG. 8