



US00D426802S

United States Patent [19]

Sacco et al.

[11] Patent Number: **Des. 426,802**

[45] Date of Patent: **** Jun. 20, 2000**

[54] **VEHICLE SIDE PANEL CONFIGURATION**

[75] Inventors: **Bruno Sacco**, Sindelfingen; **Peter Pfeiffer**, Boeblingen, both of Germany

[73] Assignee: **DaimlerChrysler AG**, Germany

[**] Term: **14 Years**

[21] Appl. No.: **29/106,310**

[22] Filed: **Jun. 15, 1999**

[30] **Foreign Application Priority Data**

Dec. 15, 1998 [DE] Germany 49812331

[51] **LOC (7) Cl.** **12-16**

[52] **U.S. Cl.** **D12/196**

[58] **Field of Search** D12/196, 90-92;
296/185

[56] **References Cited**

U.S. PATENT DOCUMENTS

- D. 385,245 10/1997 Gallitzendoerfer D12/196
- D. 391,911 3/1998 Lagaay et al. D12/196
- D. 393,439 4/1998 Lagaay et al. D12/196

D. 414,153 9/1999 Sacco et al. D12/196

Primary Examiner—Melody N. Brown
Attorney, Agent, or Firm—Evenson, McKeown, Edwards & Lenahan, P.L.L.C.

[57] **CLAIM**

The ornamental design for a vehicle side panel configuration, as shown and described.

DESCRIPTION

FIG. 1 is a front view of a first embodiment of a vehicle side panel configuration according to our novel design;
FIG. 2 is a perspective view of the first embodiment of the vehicle side panel configuration according to our novel design;

FIG. 3 is a front view of a second embodiment of the vehicle side panel configuration according to our novel design and

FIG. 4 is a perspective view of the second embodiment of the vehicle side panel configuration according to our novel design.

The broken lines shown depict environment and are not part of the claimed design.

1 Claim, 2 Drawing Sheets

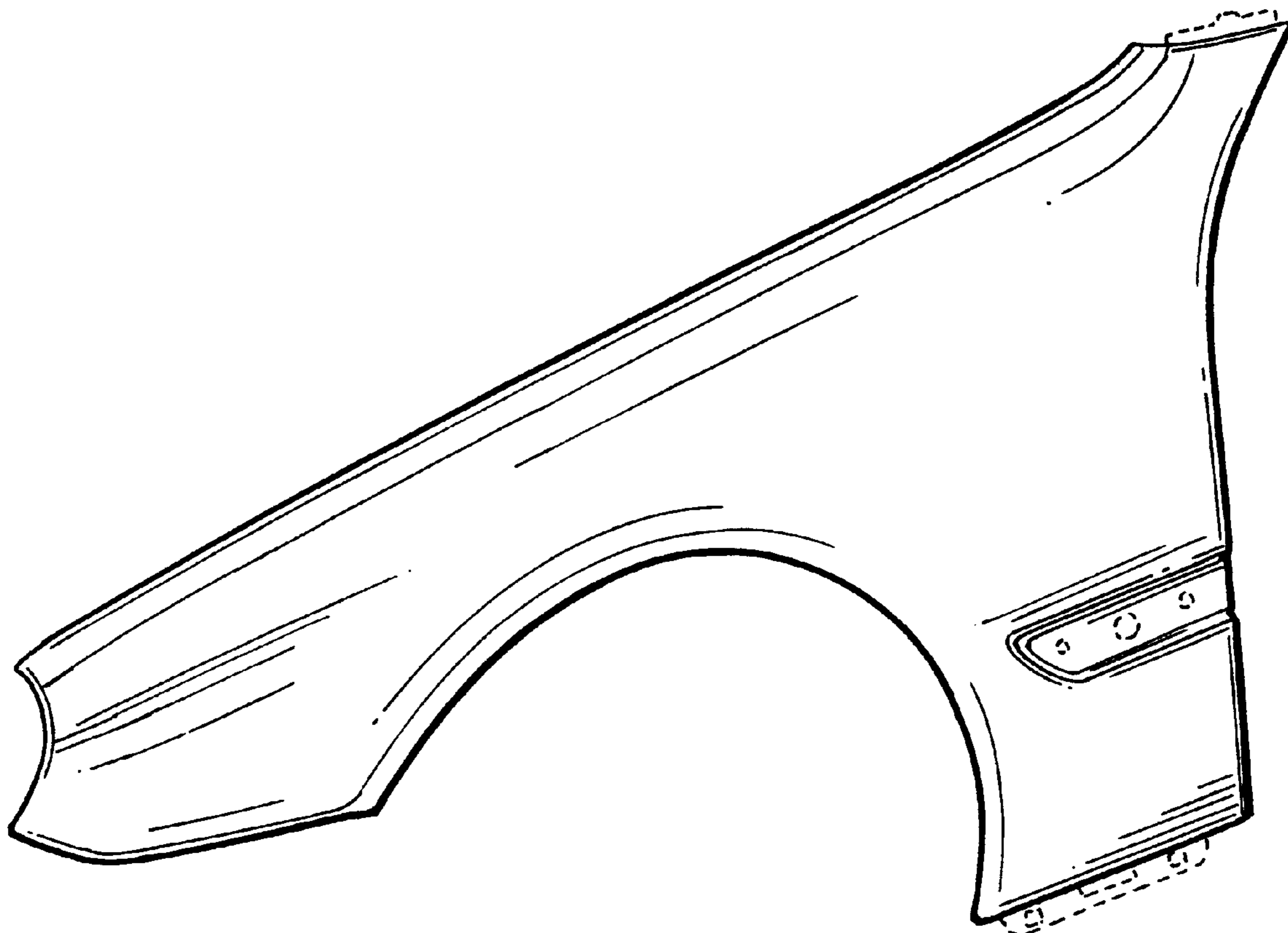

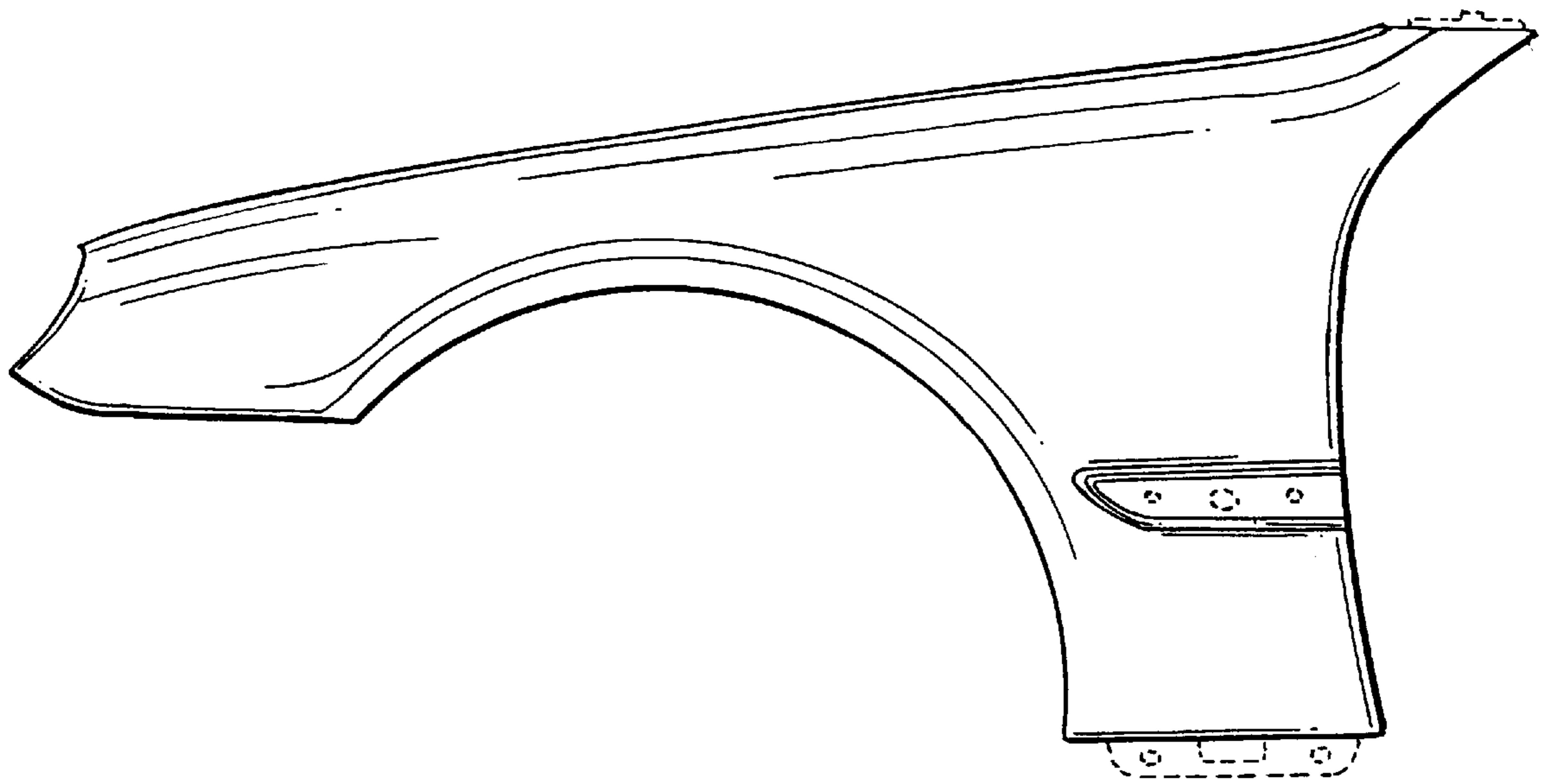

FIG. 1

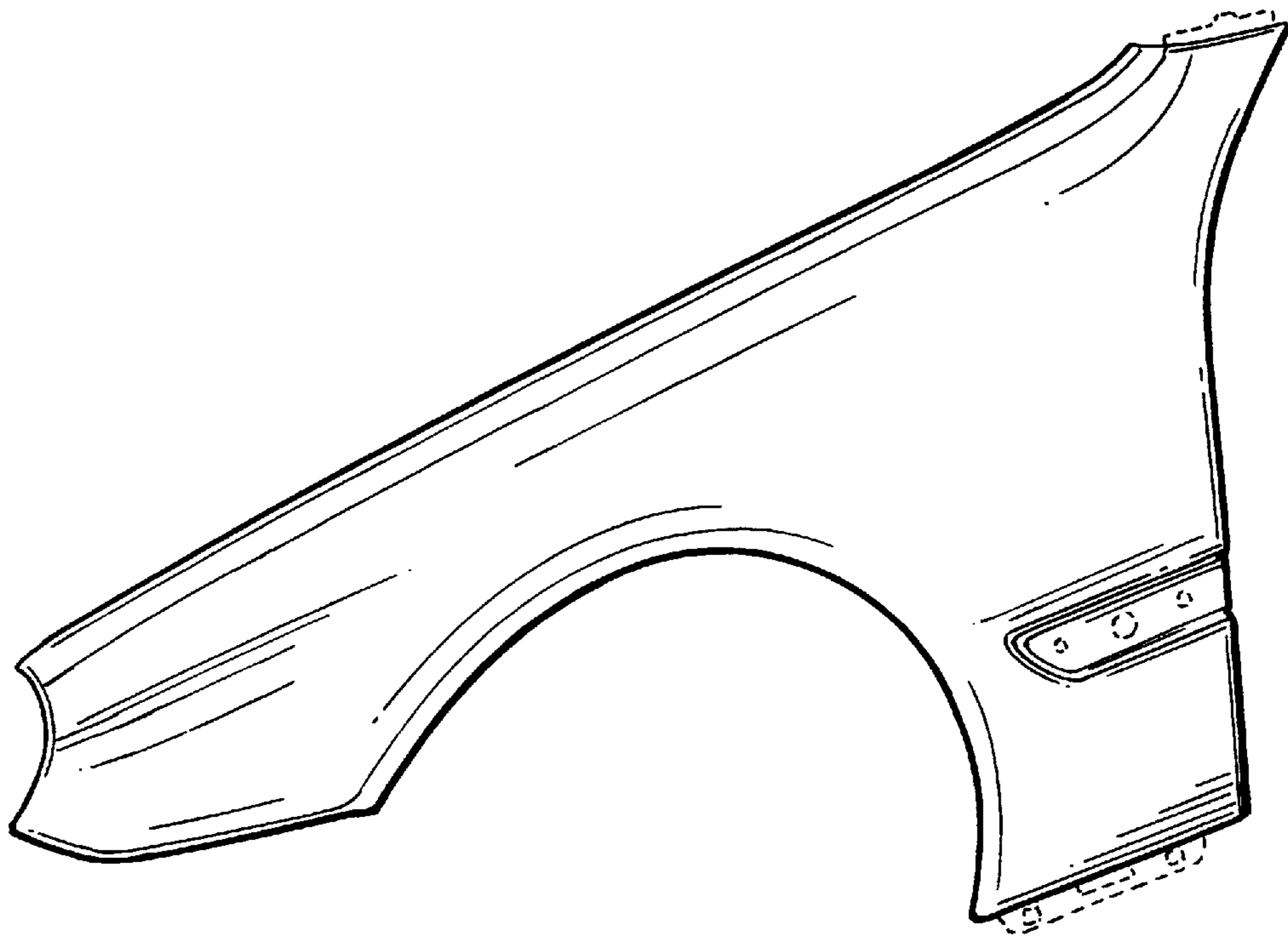

FIG. 2

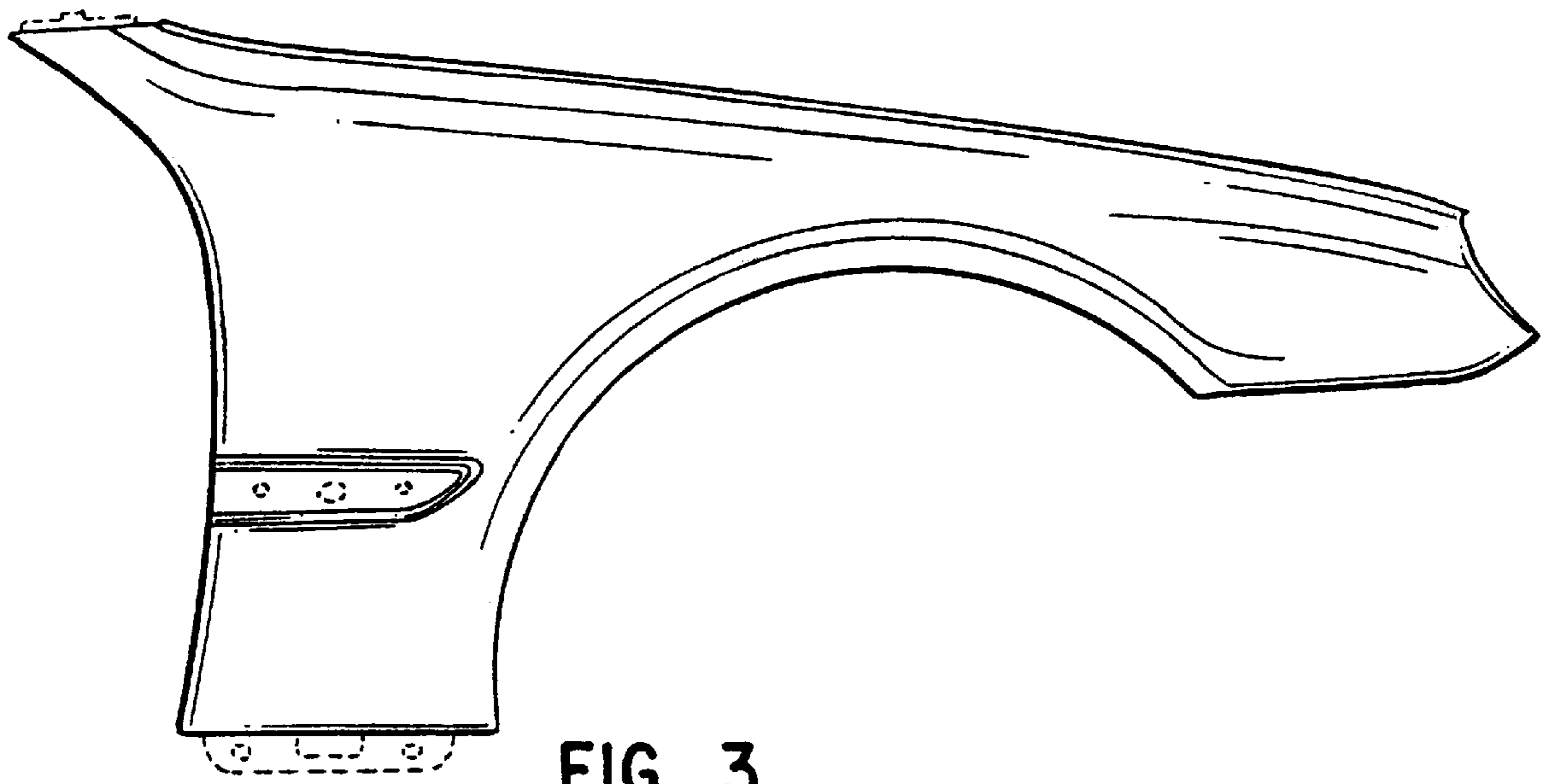

FIG. 3

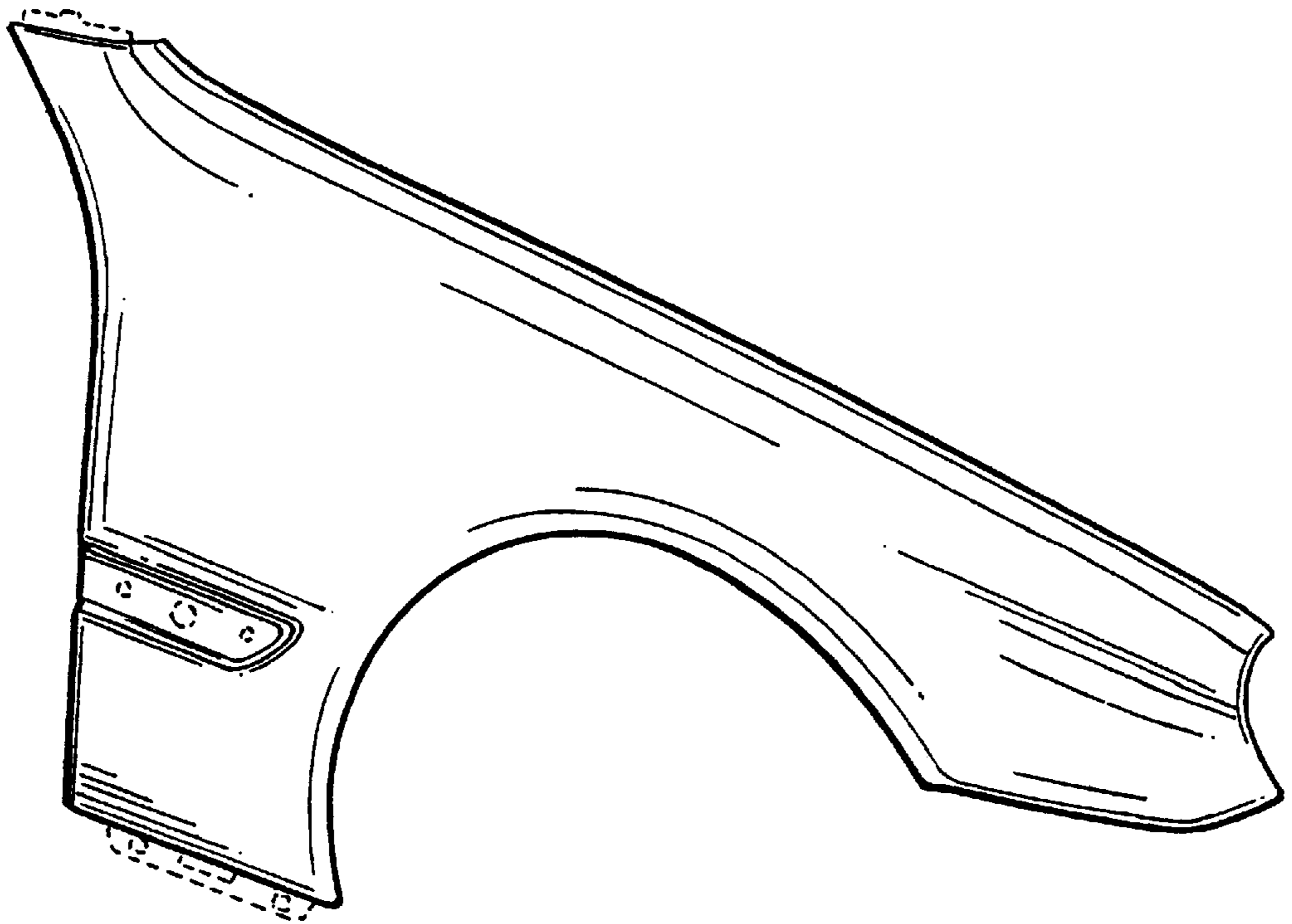

FIG. 4