



US00D426406S

# United States Patent [19] Noll

[11] **Patent Number: Des. 426,406**  
[45] **Date of Patent: \*\* Jun. 13, 2000**

[54] **PAIR OF SIDE TABLES FOR A GLIDER**

[76] Inventor: **Ronald C. Noll**, 25 Fairway Trail,  
Moreland Hills, Ohio 44022

[\*\*] Term: **14 Years**

[21] Appl. No.: **29/107,511**

[22] Filed: **Jul. 7, 1999**

[51] **LOC (7) Cl. .... 06-03**

[52] **U.S. Cl. .... D6/480; D6/511**

[58] **Field of Search .... D6/491, 501, 511,  
D6/480, 487, 486, 344, 347; 297/281, 282,  
148, 160, 170**

## [56] **References Cited**

### U.S. PATENT DOCUMENTS

D. 215,857	11/1969	Olson .	
D. 287,677	1/1987	Pomeroy et al. ....	D6/449
D. 289,588	5/1987	Winzeler, III .	
D. 290,072	6/1987	Winzeler, III .	
D. 292,150	10/1987	Restin et al. .	
D. 307,363	4/1990	Pomeroy et al. .	
D. 307,523	5/1990	Pomeroy et al. .	
D. 309,065	7/1990	Huff .	
D. 310,604	9/1990	Pomeroy et al. .	
D. 325,823	5/1992	Pomeroy et al. .	
D. 328,197	7/1992	Braxton, III .	
D. 331,332	12/1992	Farmer .	
D. 334,485	4/1993	Pomeroy et al. ....	D6/344
D. 338,563	8/1993	Chiang ....	D6/344
D. 350,855	9/1994	Pomeroy et al. ....	D6/344
D. 362,349	9/1995	Pomeroy et al. .	
D. 365,692	1/1996	Pomeroy et al. .	
D. 389,675	1/1998	Noll ....	D6/487

D. 390,051	2/1998	Noll .
D. 400,720	11/1998	Pomeroy et al. .
3,166,354	1/1965	Sorenson .
3,191,992	6/1965	McMasters .
3,194,600	7/1965	Junkunc .
3,567,284	3/1971	Miller et al. .
3,825,299	7/1974	Gaucher .
3,894,496	7/1975	Phillips et al. .
5,653,499	8/1997	Goodall .
5,667,273	9/1997	Noll .
5,765,911	6/1998	Sorenson .
5,893,607	4/1999	Trimnell .

### OTHER PUBLICATIONS

Sunstar Brownie Mfg. Co., "Tete-A-Tete Tray" at bottom and far right.

*Primary Examiner*—Janice E. Seeger  
*Attorney, Agent, or Firm*—Pearne, Gordon, McCoy & Granger LLP

## [57] **CLAIM**

The ornamental design for a pair of side tables for a glider, as shown and described.

### DESCRIPTION

FIG. 1 is a perspective view of a pair of side tables for a glider, showing my new design.  
FIG. 2 is a top plan view thereof.  
FIG. 3 is a front elevational view thereof.  
FIG. 4 is a side elevational view thereof.  
FIG. 5 is a rear elevational view thereof; and,  
FIG. 6 is a bottom plan view thereof.  
The broken lines are for environmental purposes only and form no part of the claimed design.

**1 Claim, 4 Drawing Sheets**

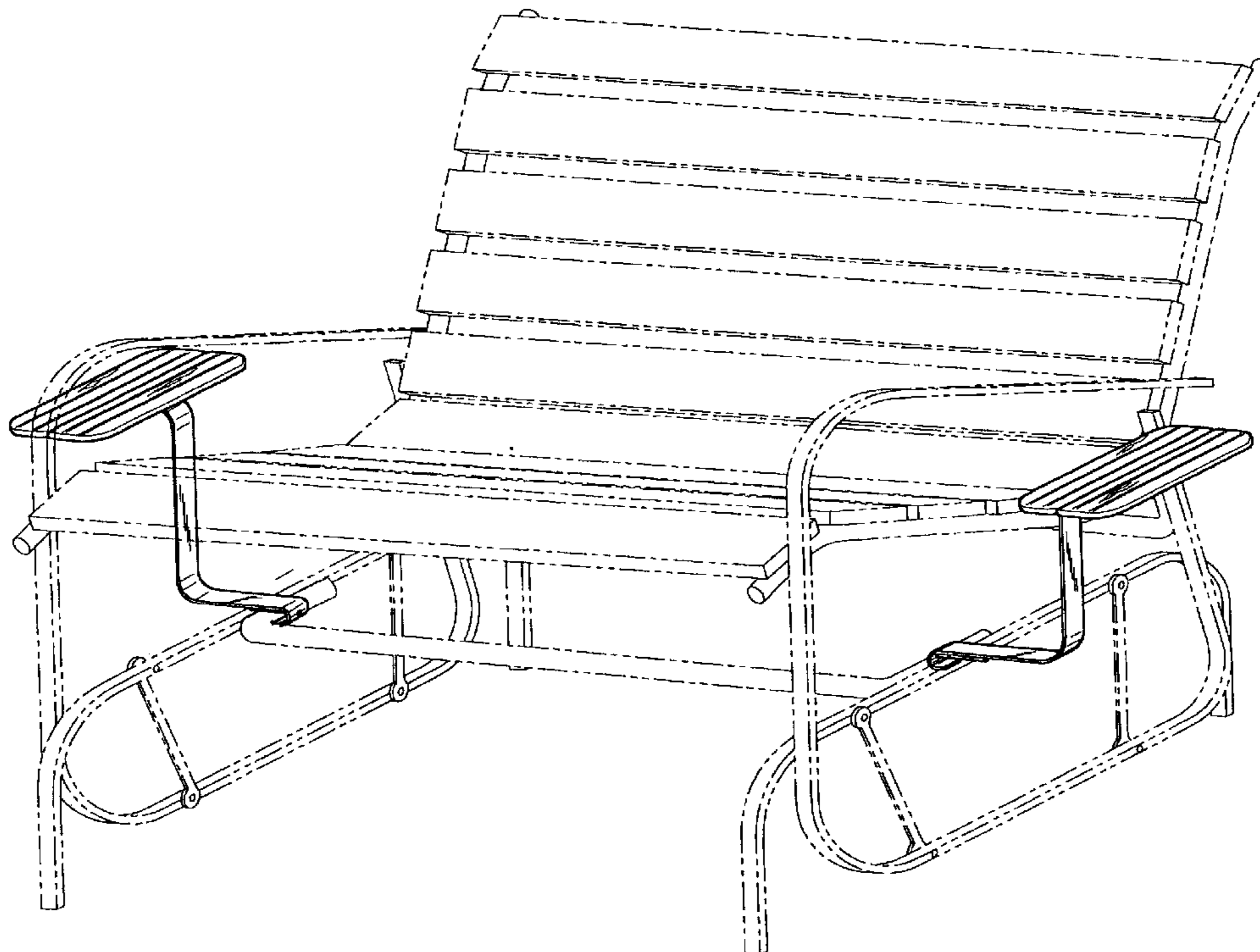
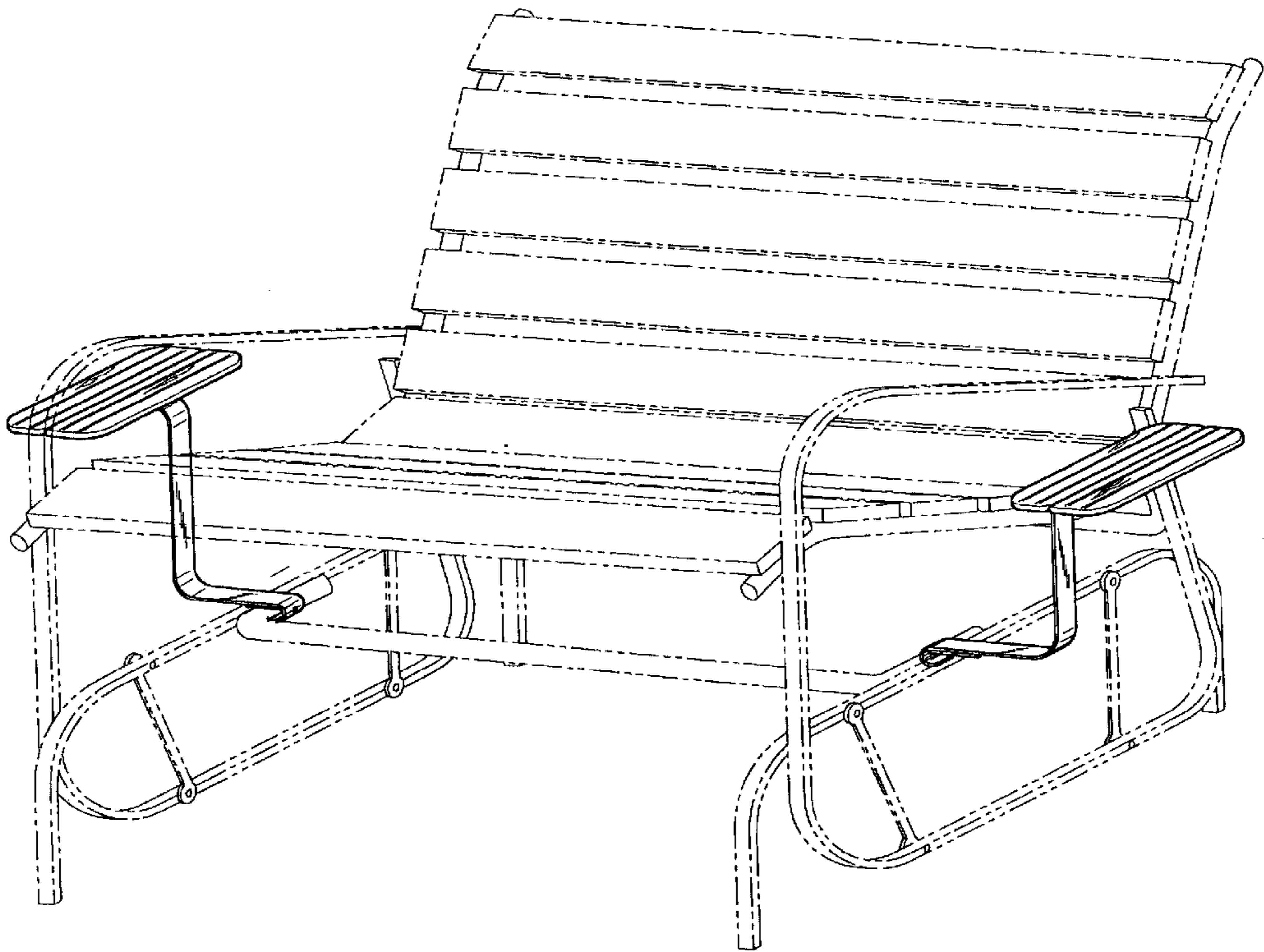

Fig. 1



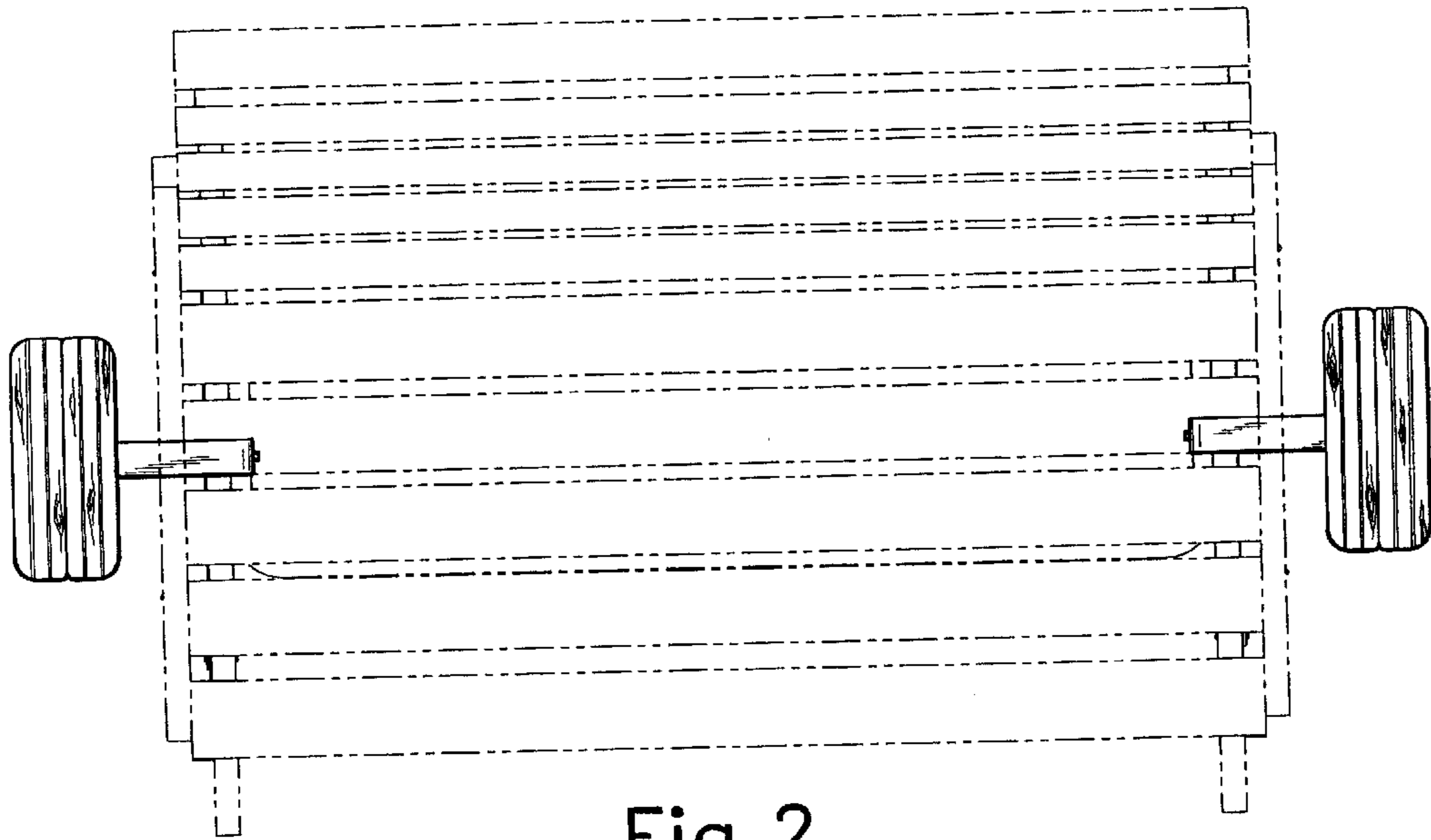

Fig. 2

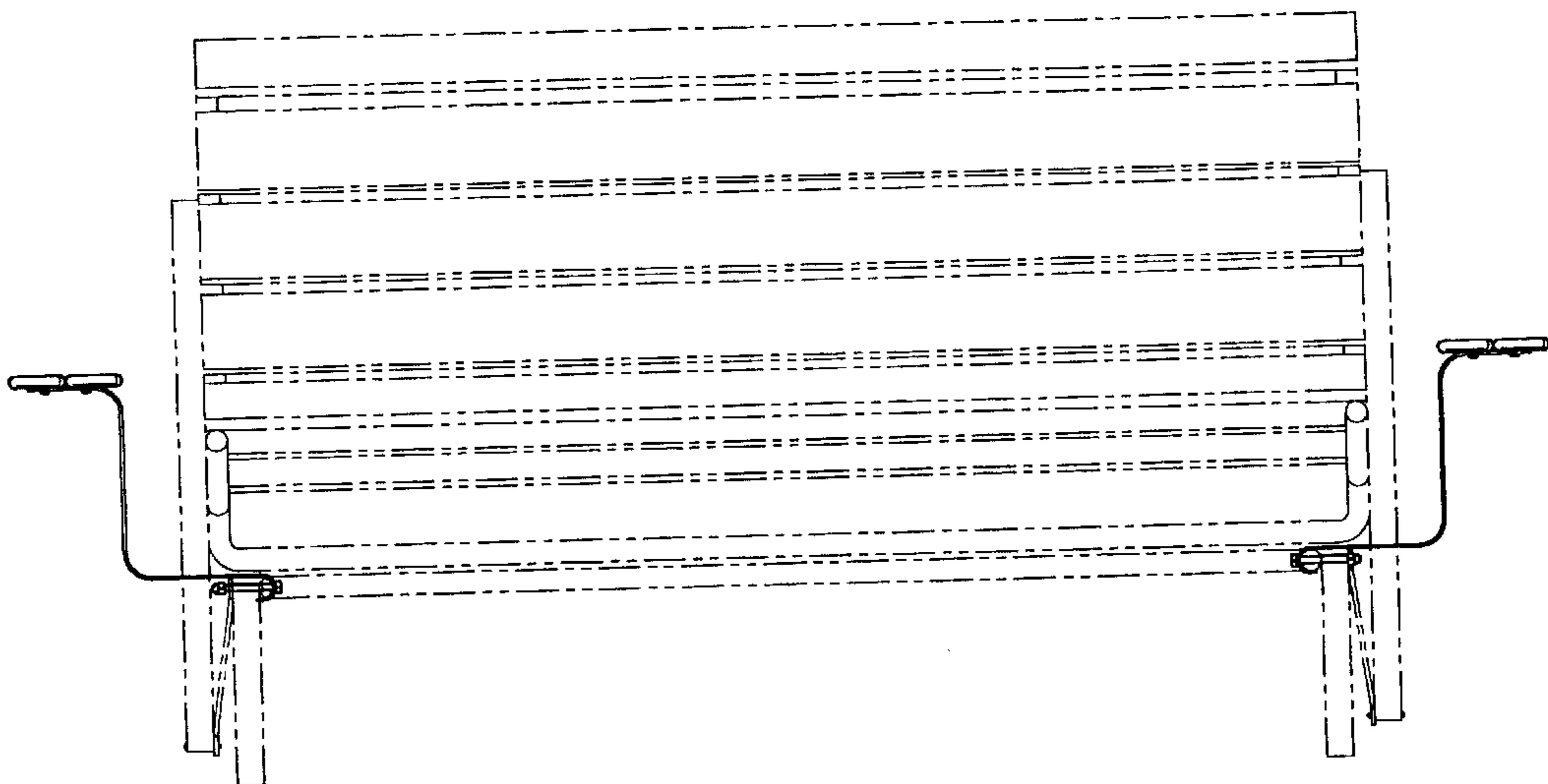

Fig. 3

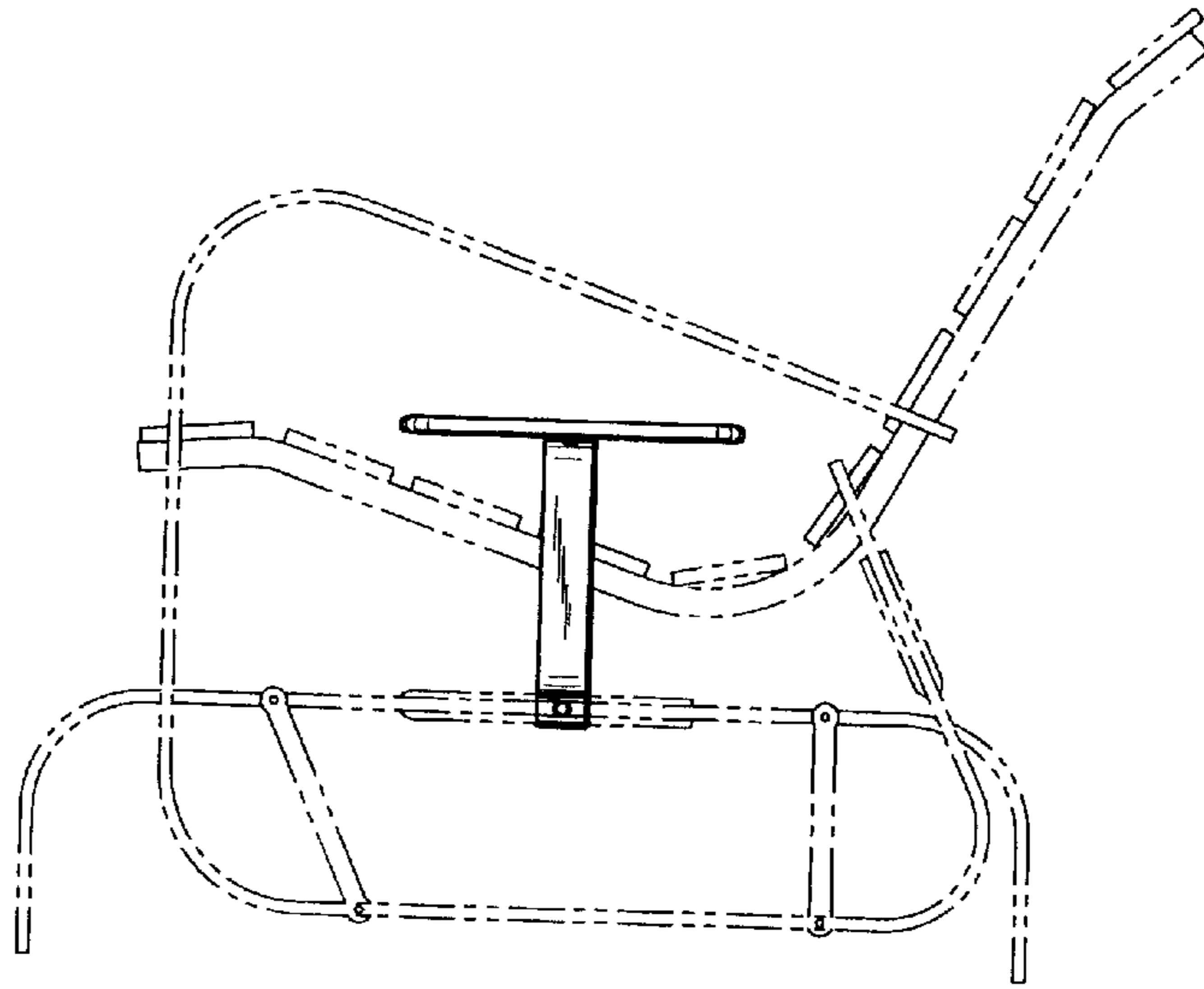

Fig.4

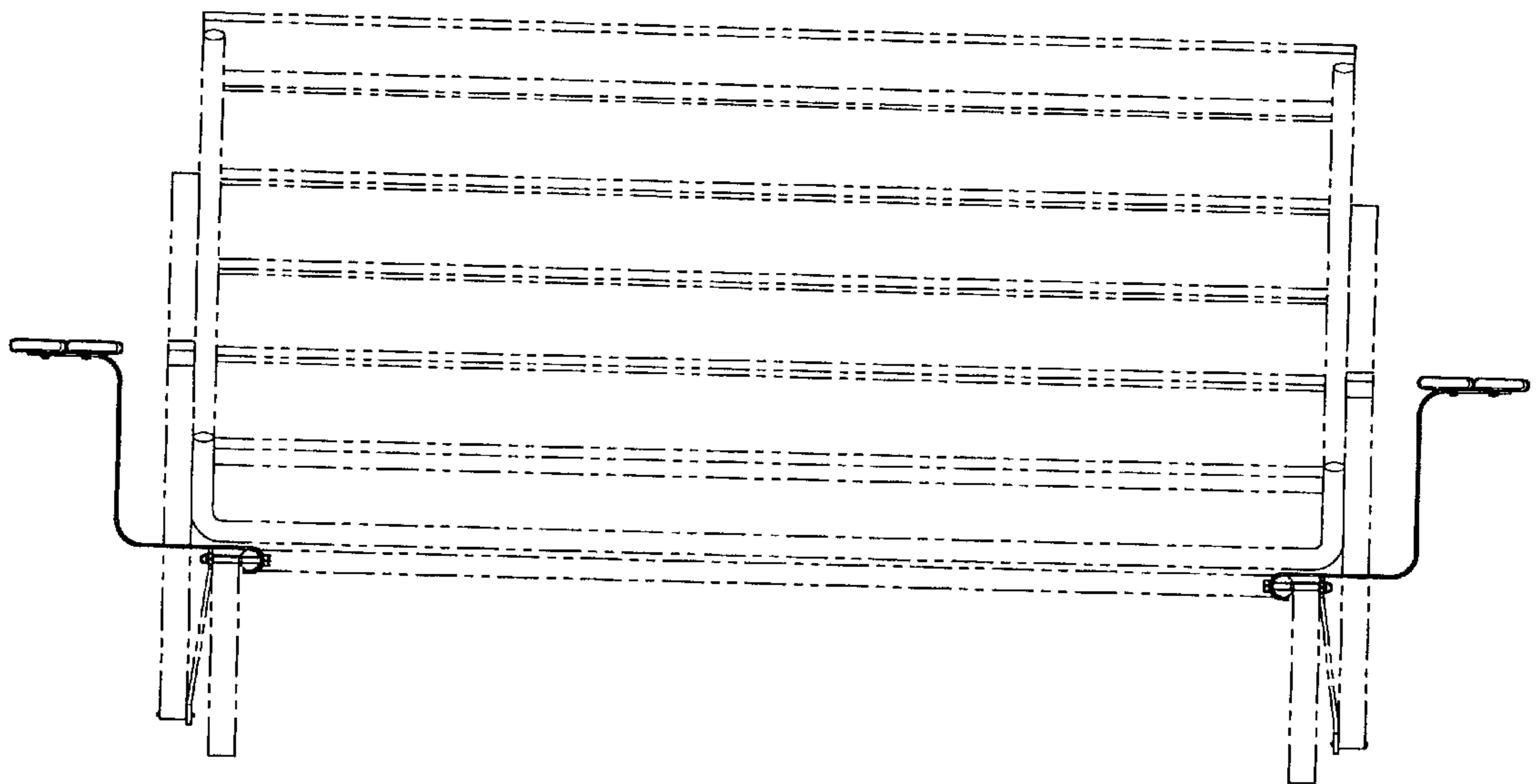

Fig.5

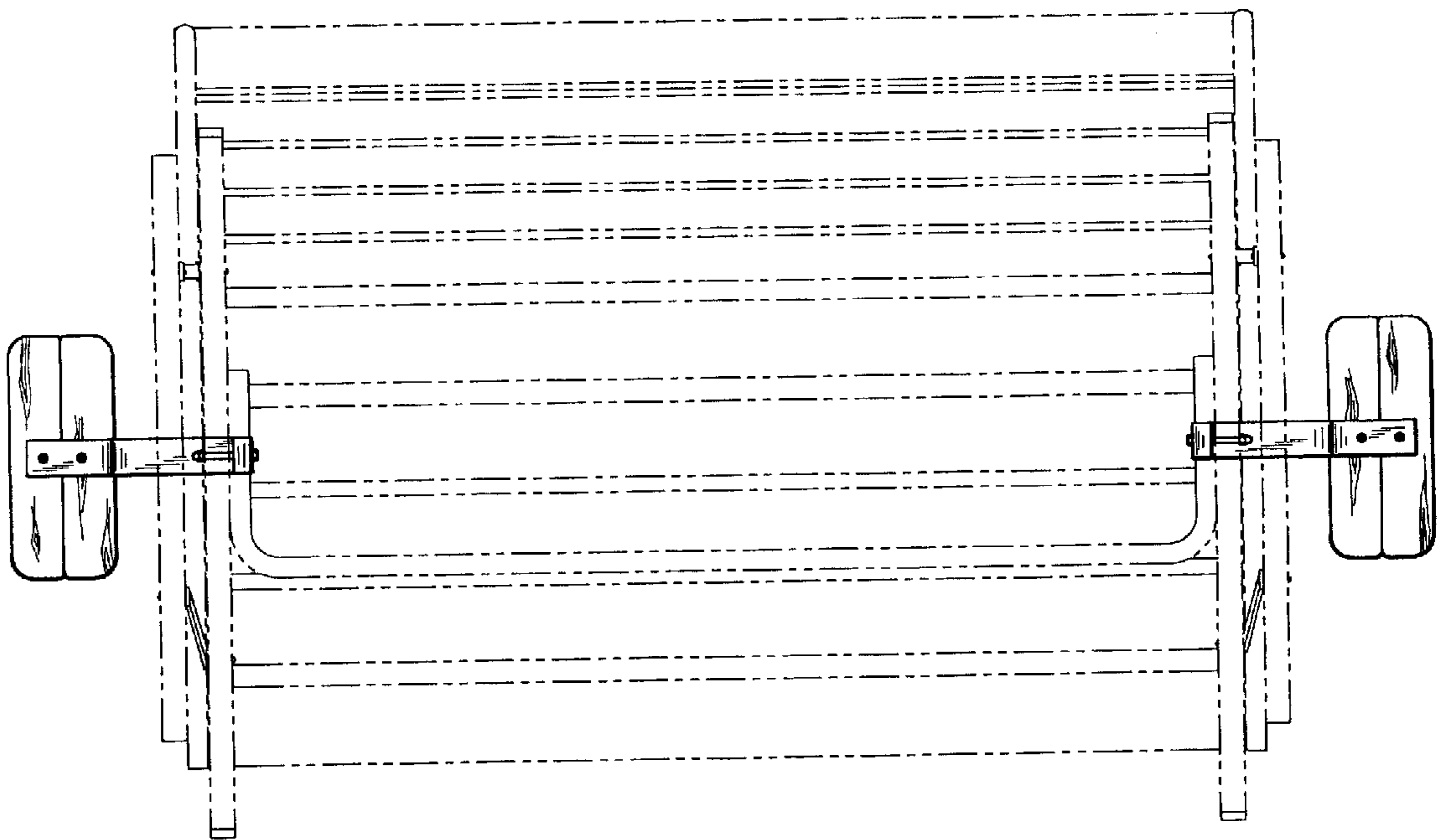

Fig.6