



US00D426244S

United States Patent [19] Grant

[11] **Patent Number: Des. 426,244**
[45] **Date of Patent: ** Jun. 6, 2000**

[54] **MACHINE HAVING ADJUSTABLE KNIVES FOR CONTINUOUSLY SLITTING A ROLL OF MATERIAL INTO STRIPS OF PREDETERMINED WIDTH**

[76] Inventor: **Randall D. Grant**, 728 Skidmore Rd., Bidwell, Ohio 45614

[**] Term: **14 Years**

[21] Appl. No.: **29/082,083**

[22] Filed: **Jan. 14, 1998**

[51] **LOC (7) Cl. 15-09**

[52] **U.S. Cl. D15/127**

[58] **Field of Search D15/127; 82/1.11, 82/129; 409/199; 451/49; 242/555.4, 556.1**

[56] **References Cited**

U.S. PATENT DOCUMENTS

4,790,698 12/1988 Heffron 409/199 X

Primary Examiner—Antoine Duval Davis

[57] **CLAIM**

I claim the ornamental design for a machine having adjustable knives for continuously slitting a roll of material into strips of predetermined width, as shown.

DESCRIPTION

FIG. 1 is a top, front and left side perspective view of a machine having adjustable knives for continuously slitting a roll of material into strips of predetermined width showing my new design;

FIG. 2 is a top, front and right side perspective view;

FIG. 3 is another top, front and left side perspective view; and,

FIG. 4 is another top, front and right side perspective view thereof.

The broken lines shown in FIG. 1. of the drawings are for illustrive purposes only and form no part of the claimed design.

1 Claim, 4 Drawing Sheets

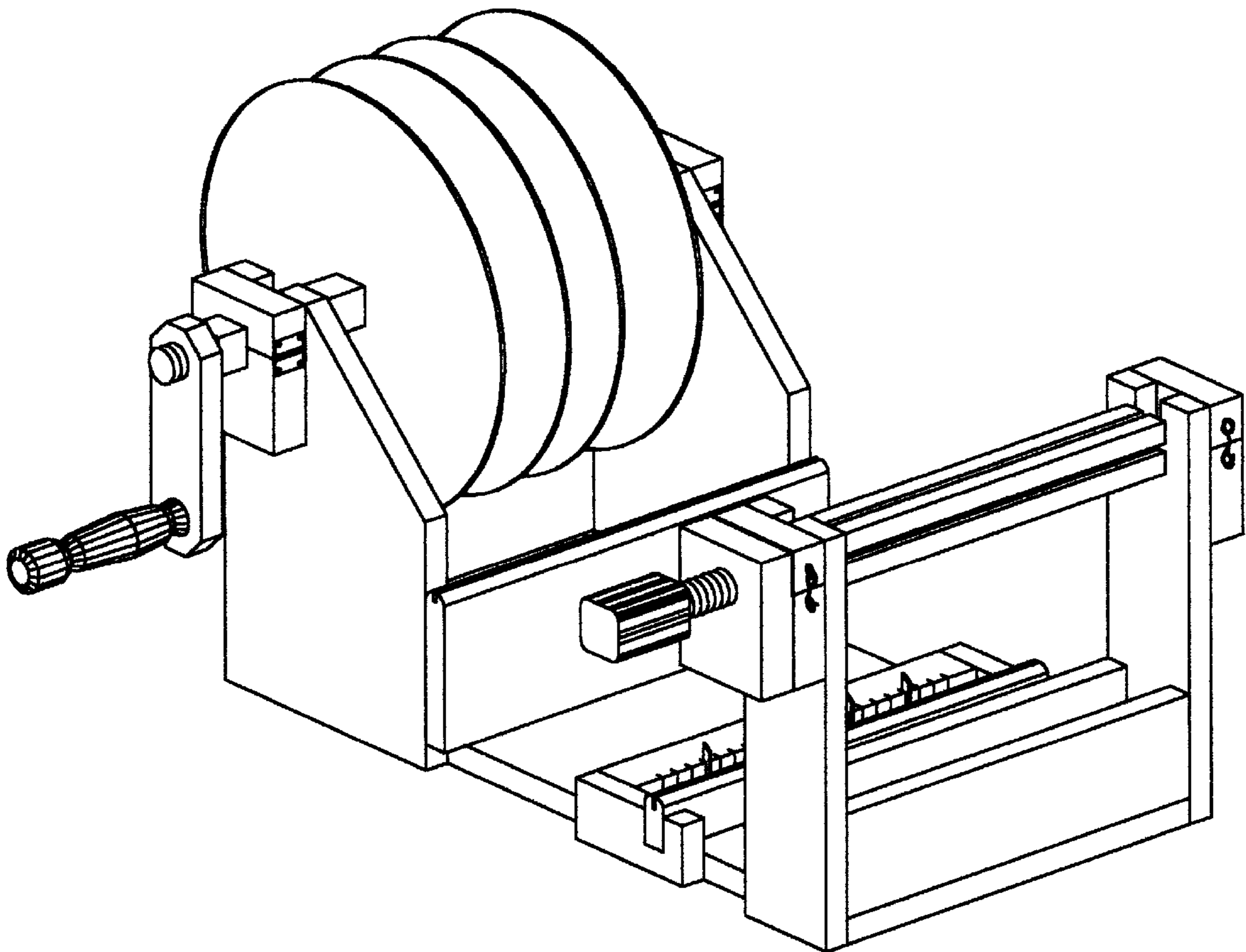

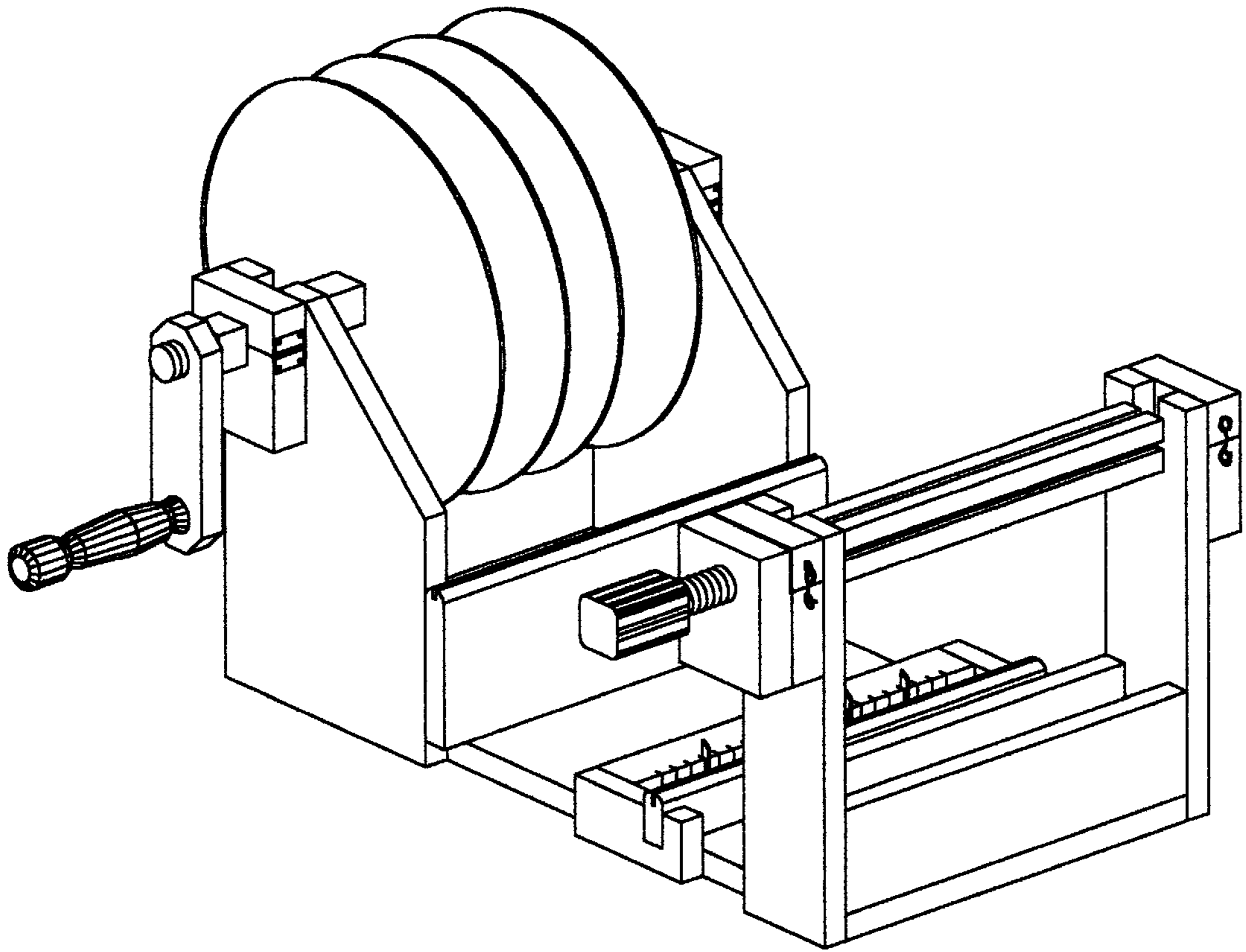

FIG. 1

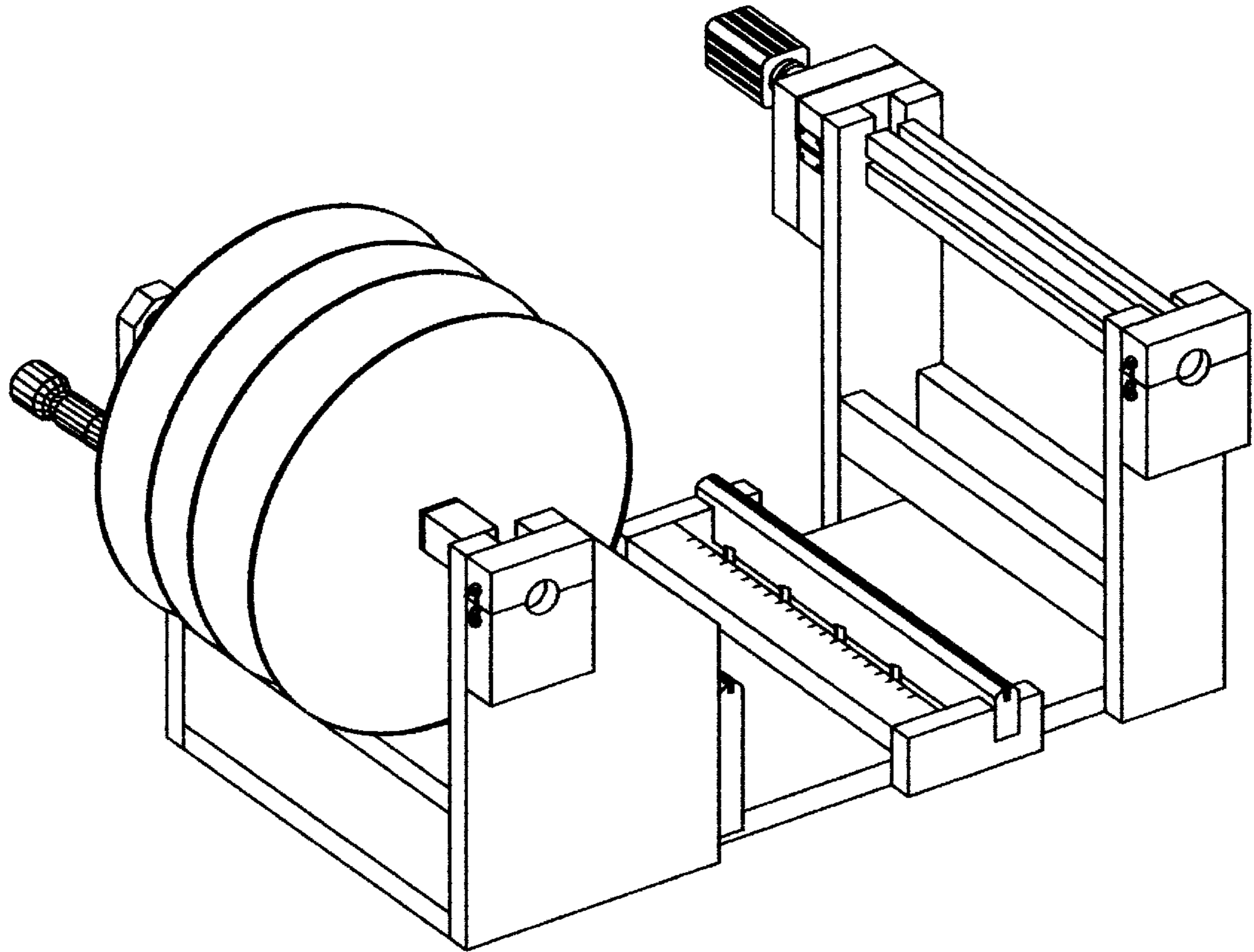

FIG. 2

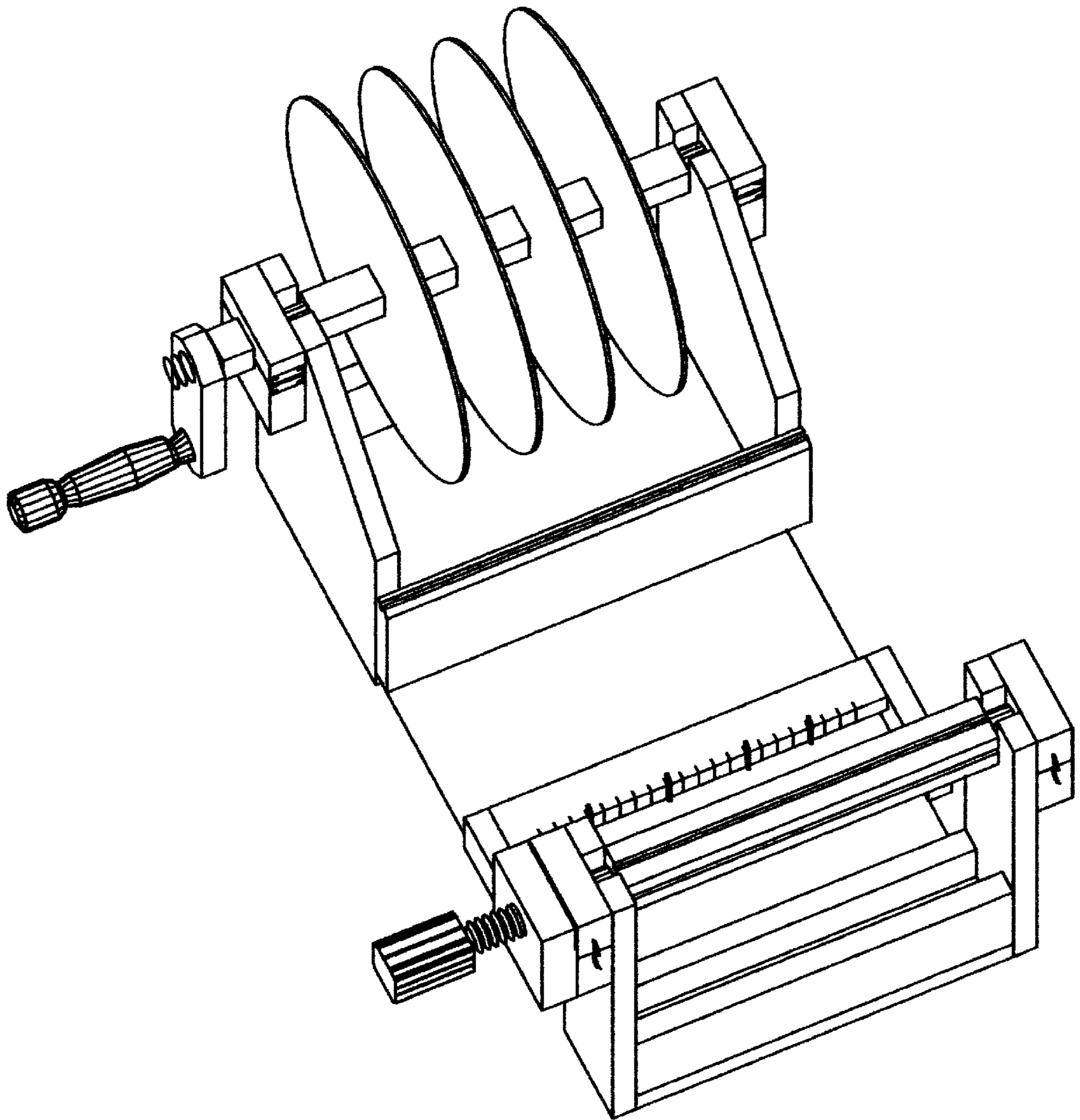

FIG. 3

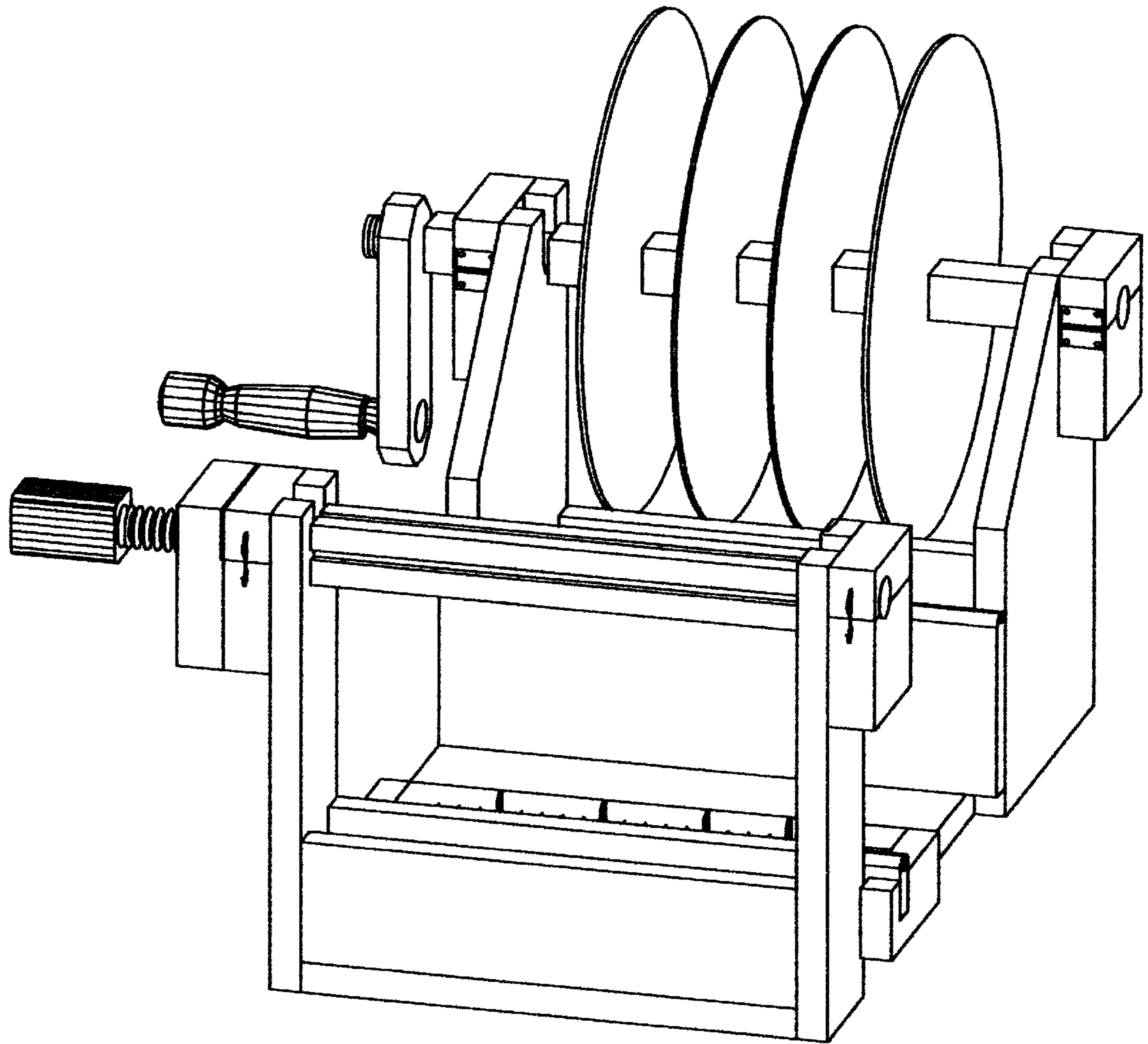

FIG. 4