



US00D426183S

United States Patent [19]

Brooks, II et al.

[11] Patent Number: Des. 426,183

[45] Date of Patent: ** Jun. 6, 2000

[54] WINDSHIELD VISOR EXTENSION

[76] Inventors: **Leon Brooks, II; Gail Brooks**, both of
615 Cairns St., Grand Lake, Colo.
80447

[**] Term: **14 Years**

[21] Appl. No.: **29/074,695**

[22] Filed: **Jul. 31, 1997**

[51] LOC (7) Cl. **12-16**

[52] U.S. Cl. **D12/191**

[58] Field of Search D12/191, 190,
D12/417; D5/15; 296/97.1, 97.6-97.12;
160/370.21-370.23, DIG. 3; 224/312

[56] **References Cited**

U.S. PATENT DOCUMENTS

D. 208,975	10/1967	Koubele	D12/191
D. 217,343	4/1970	Seida	D12/191
D. 220,618	5/1971	Berkoff	D12/191
D. 310,653	9/1990	Aizawa et al.	D12/191
D. 310,810	9/1990	Lewis	D12/191
D. 339,785	9/1993	Schierau	D12/191
D. 344,530	2/1994	Johnson	D12/191
D. 351,127	10/1994	Baylon	D12/191
D. 361,970	9/1995	Zetterlund	D12/191
D. 398,893	9/1998	Lyons	D12/191
D. 405,746	2/1999	Larson	D12/191
2,921,813	1/1960	Lowry	296/97.1

Primary Examiner—Doris V. Coles
Assistant Examiner—Stacia Sinuik

Attorney, Agent, or Firm—John B. Phillips; Gregg I. Anderson

[57] **CLAIM**

The ornamental design for a windshield visor extension, as shown and described.

DESCRIPTION

FIG. 1 is a front perspective view of a windshield visor extension showing the first embodiment of our new design; FIG. 2 is a front elevation view thereof. FIG. 3 is a top view thereof. FIG. 4 is a rear elevation view thereof. FIG. 5 is a bottom view thereof. FIG. 6 is a right side elevation view thereof. FIG. 7 is a left side elevation view thereof. FIG. 8 is a front perspective view of a windshield visor extension showing the second embodiment of our new design, the only difference being the transparency of the material; FIG. 9 is a front elevation thereof. FIG. 10 is a top view thereof. FIG. 11 is a rear elevation view thereof. FIG. 12 is a bottom view thereof. FIG. 13 is a right side elevation view thereof. FIG. 14 is a left side elevation view thereof; and, FIG. 15 is a reduced perspective view of the windshield visor extension of FIG. 1 shown with the visor portion extended to the left and attached to a visor of a vehicle; it being understood that the broken lines are for illustrative purposes only and form no part of the claimed design.

1 Claim, 7 Drawing Sheets

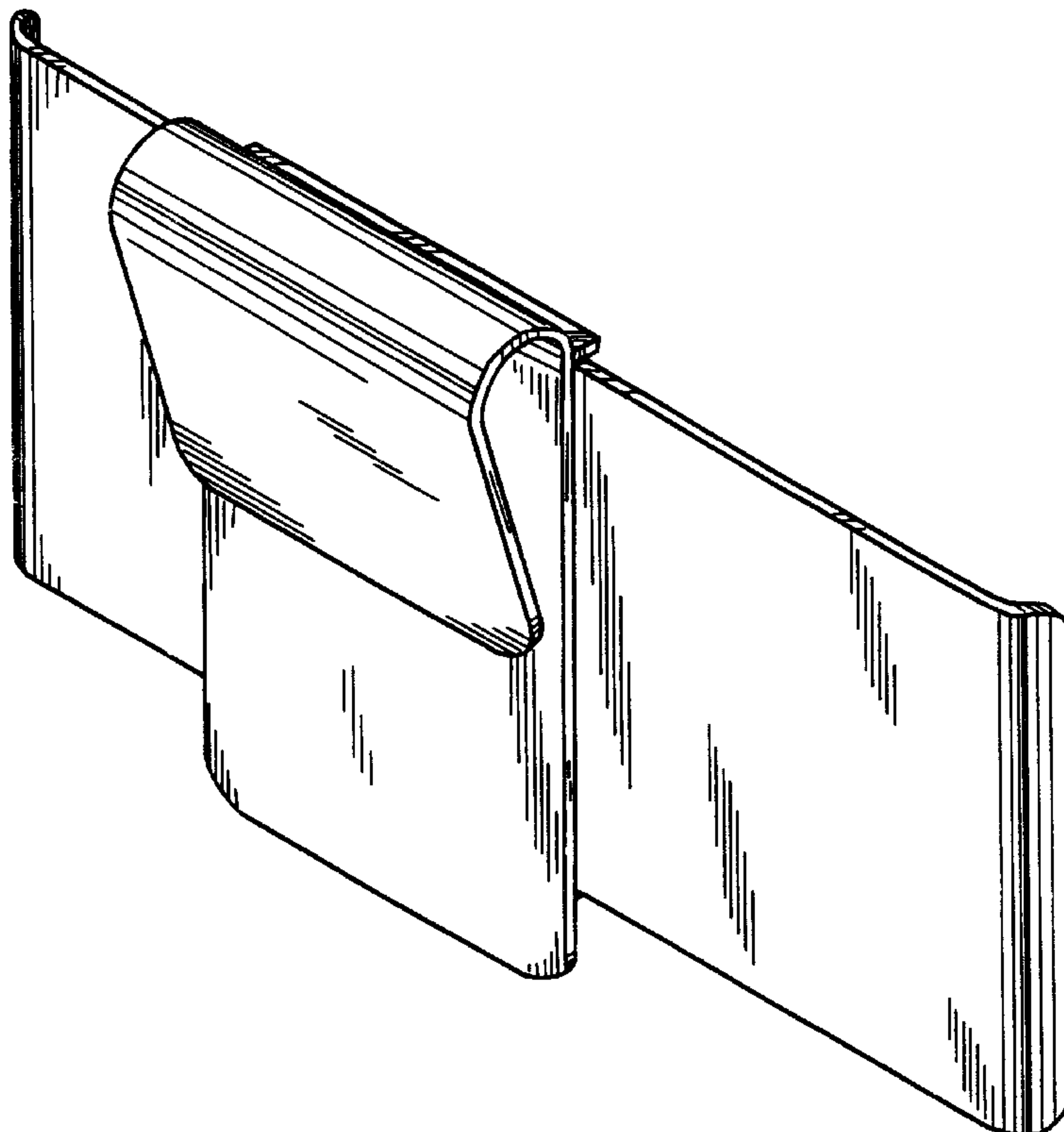

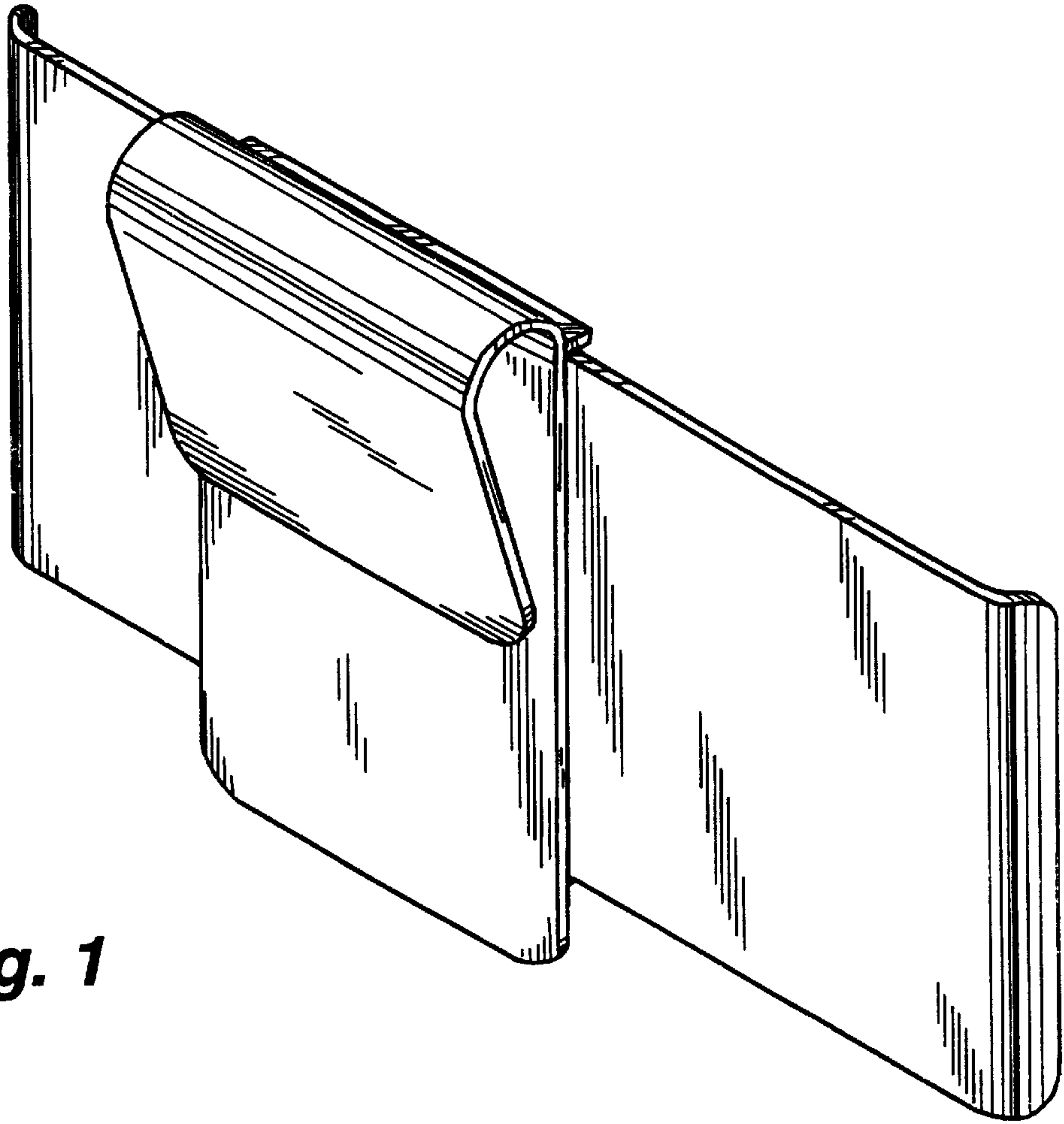

Fig. 1

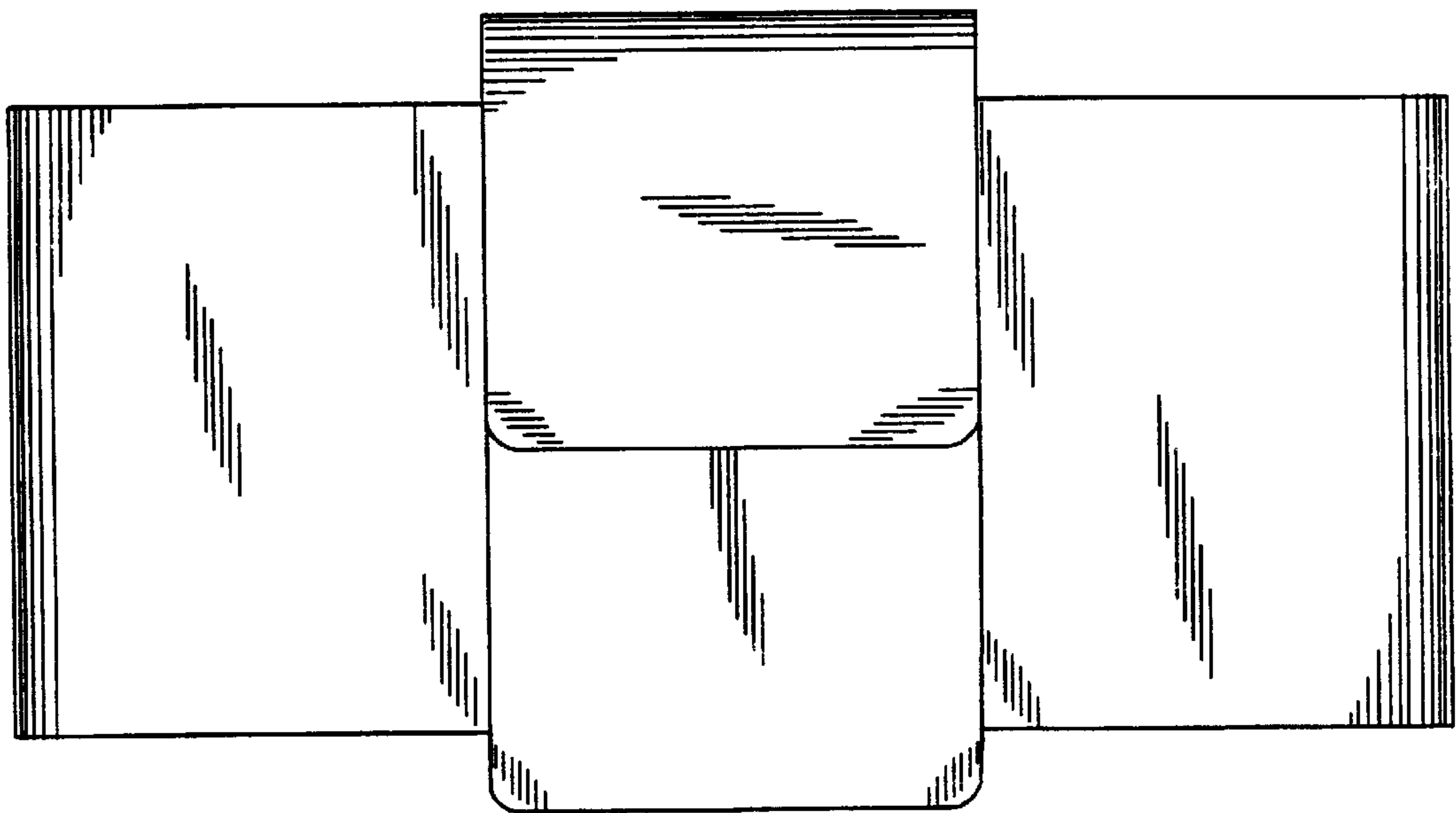

Fig. 2

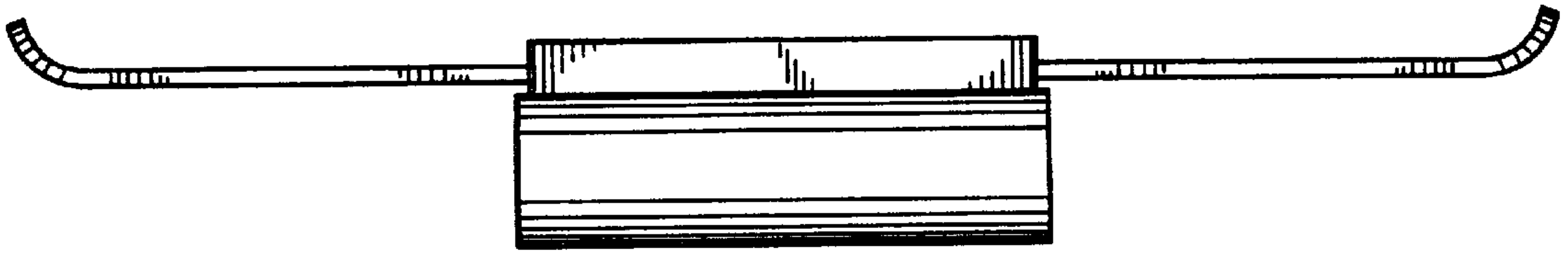

Fig. 3

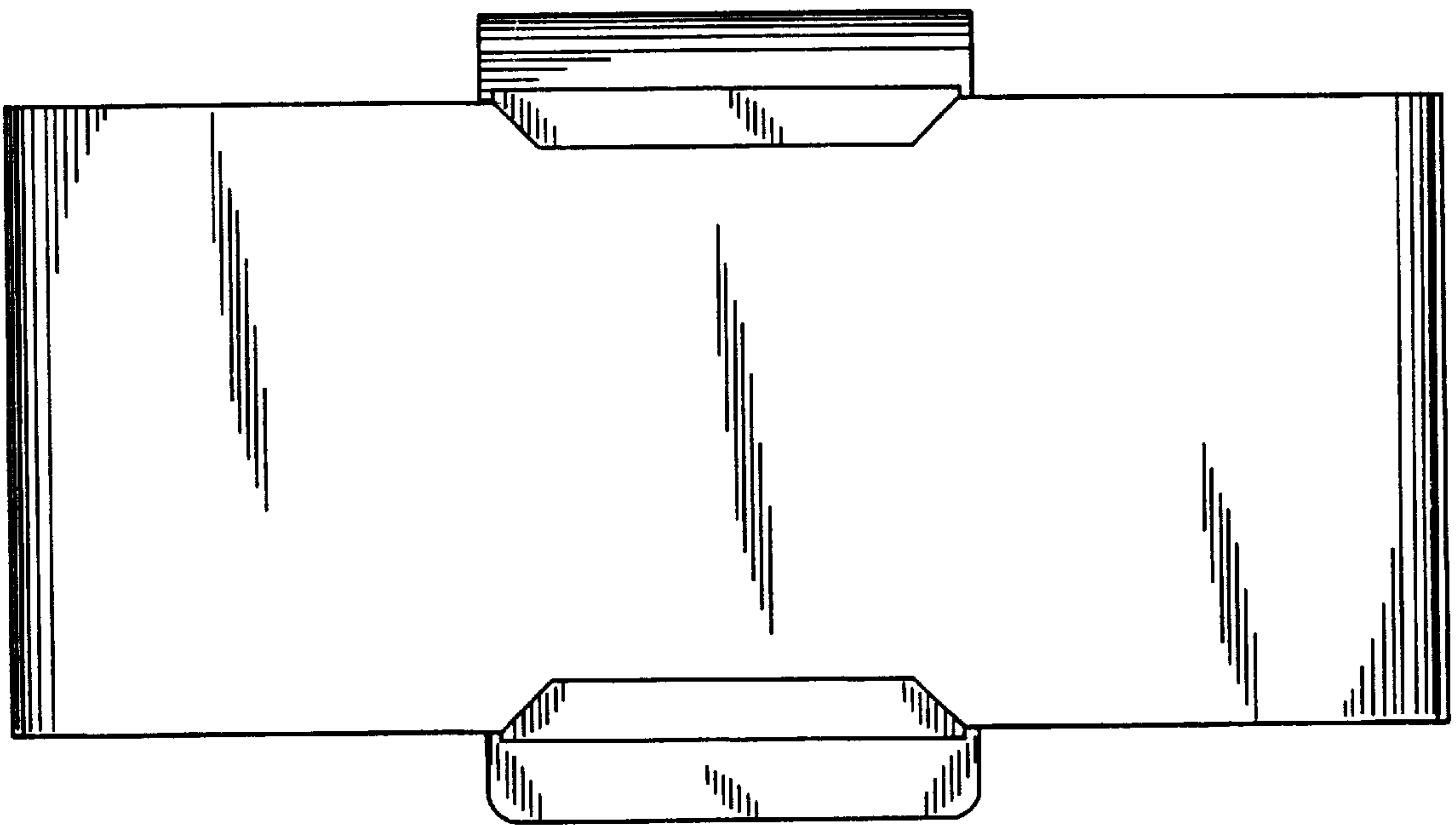

Fig. 4

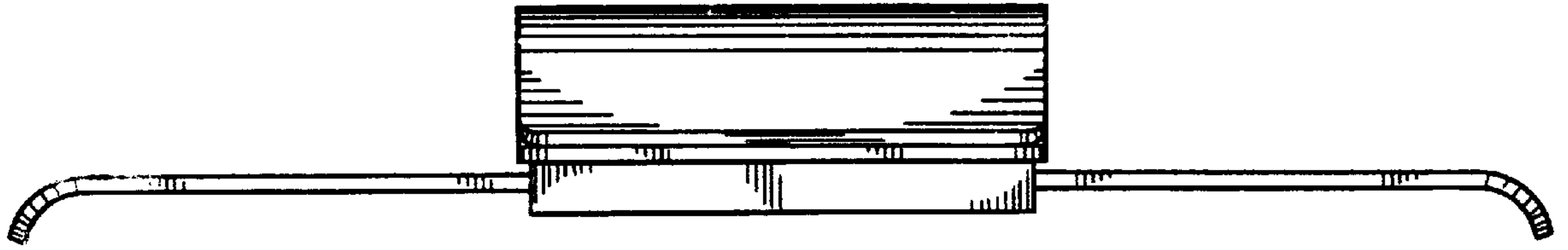

Fig. 5



Fig. 6

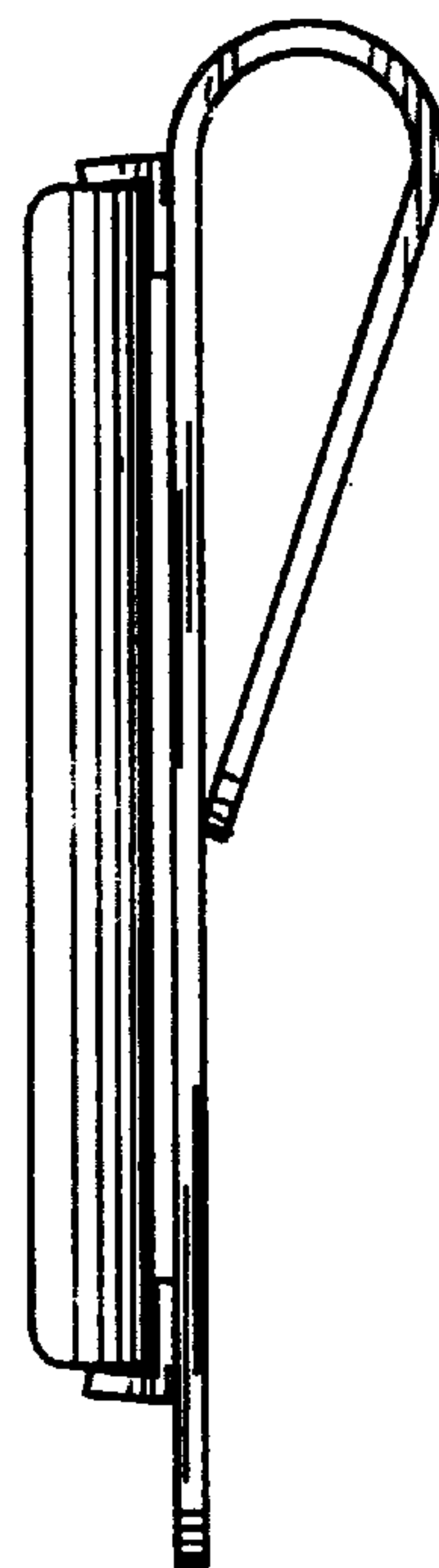

Fig. 7

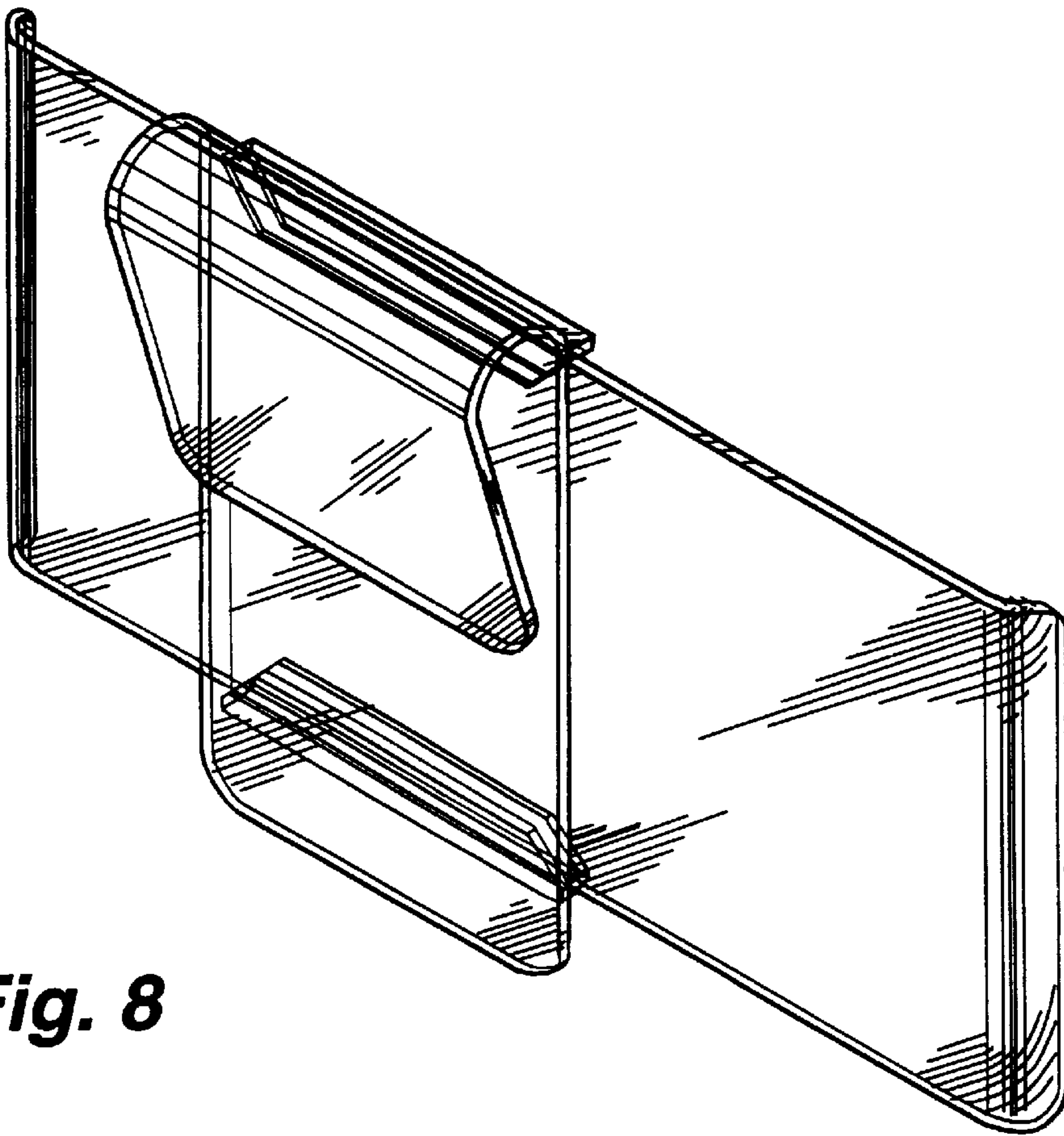

Fig. 8

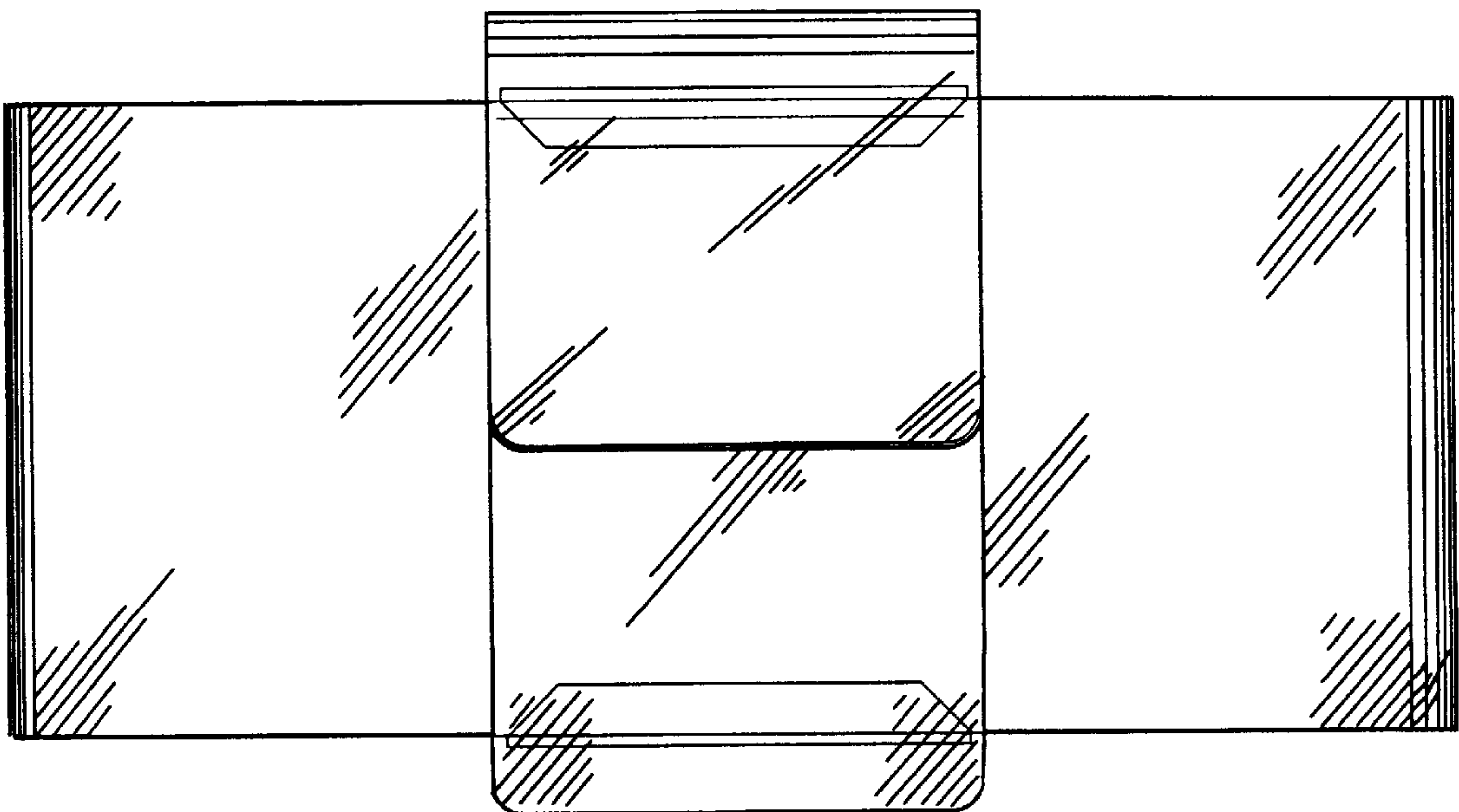

Fig. 9

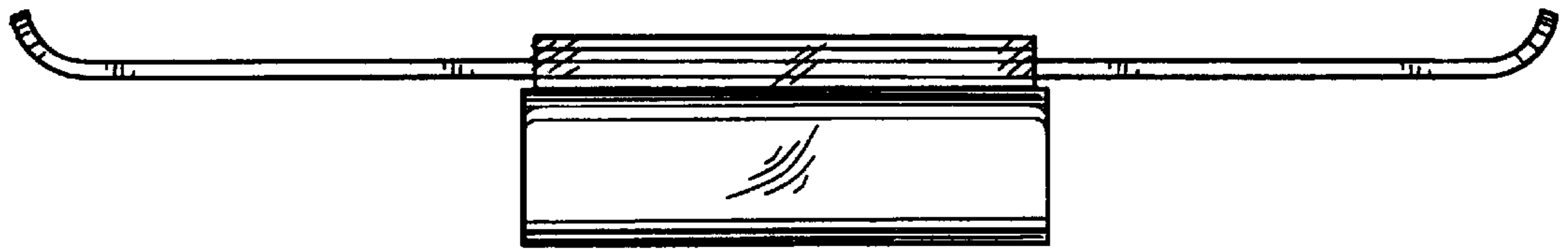

Fig. 10

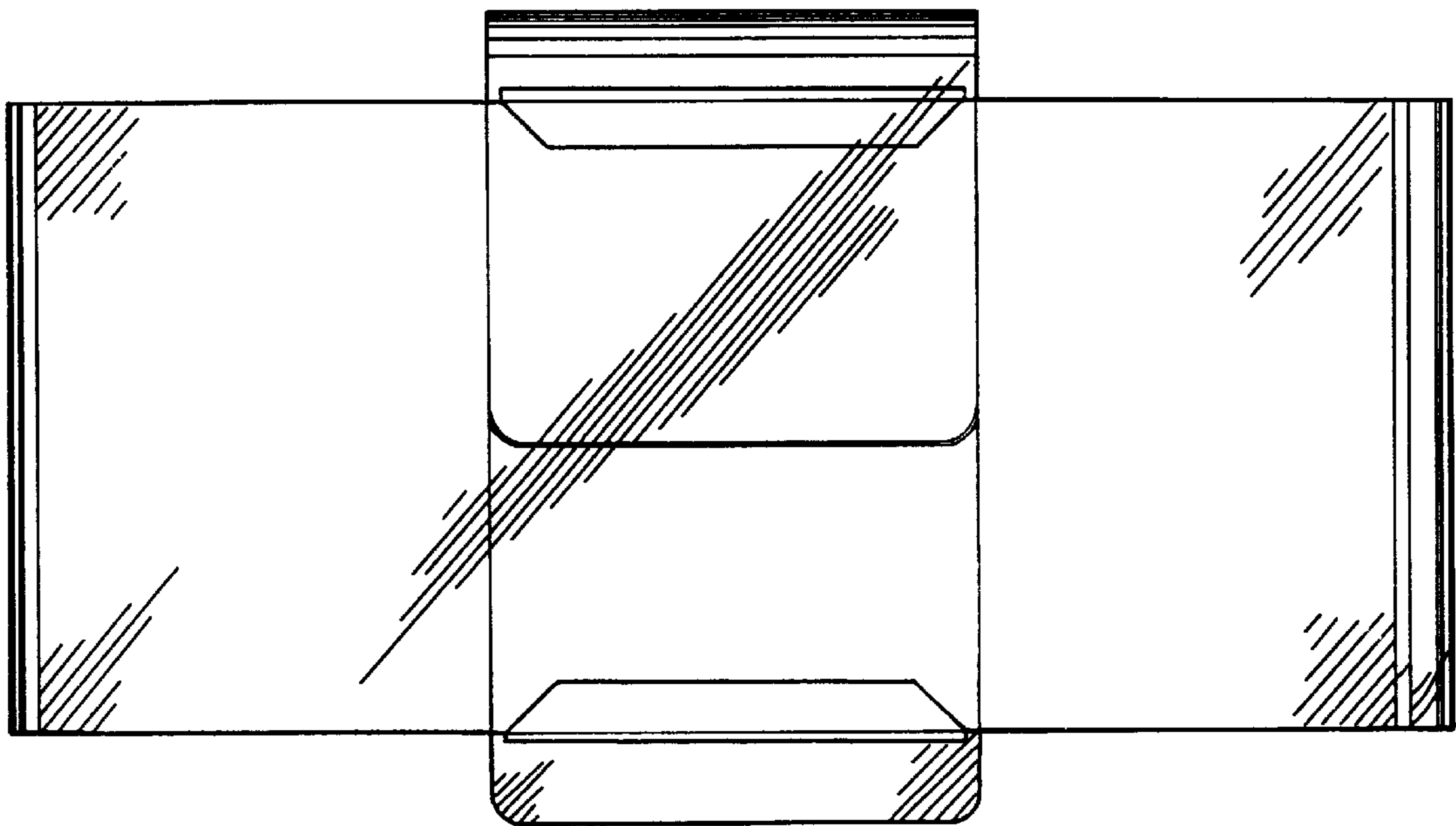

Fig. 11

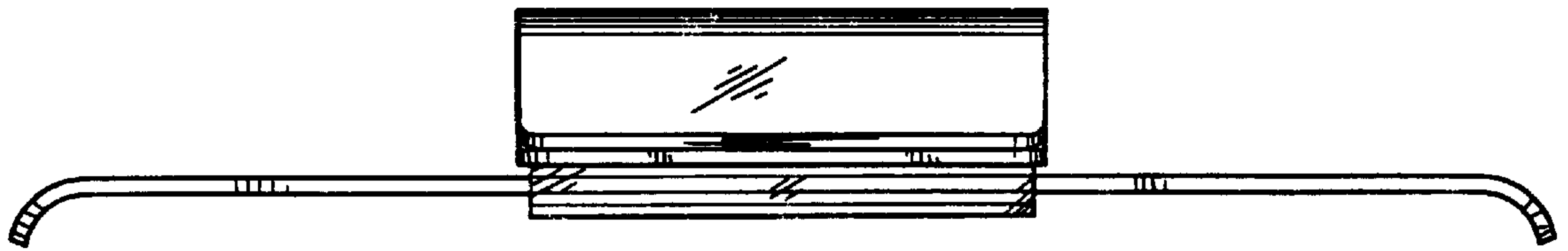

Fig. 12

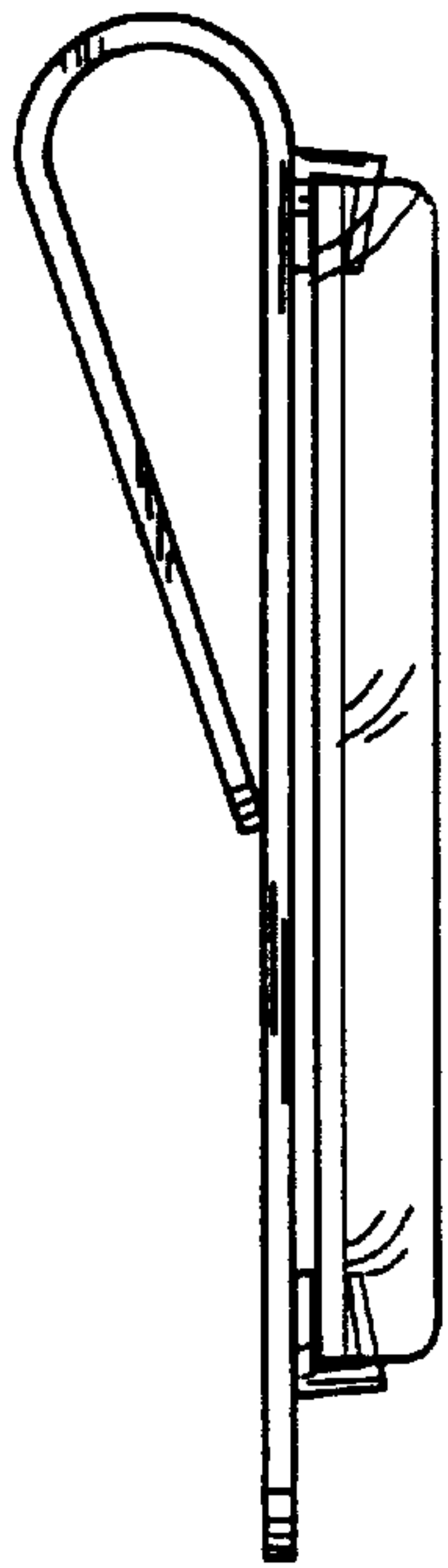

Fig. 13

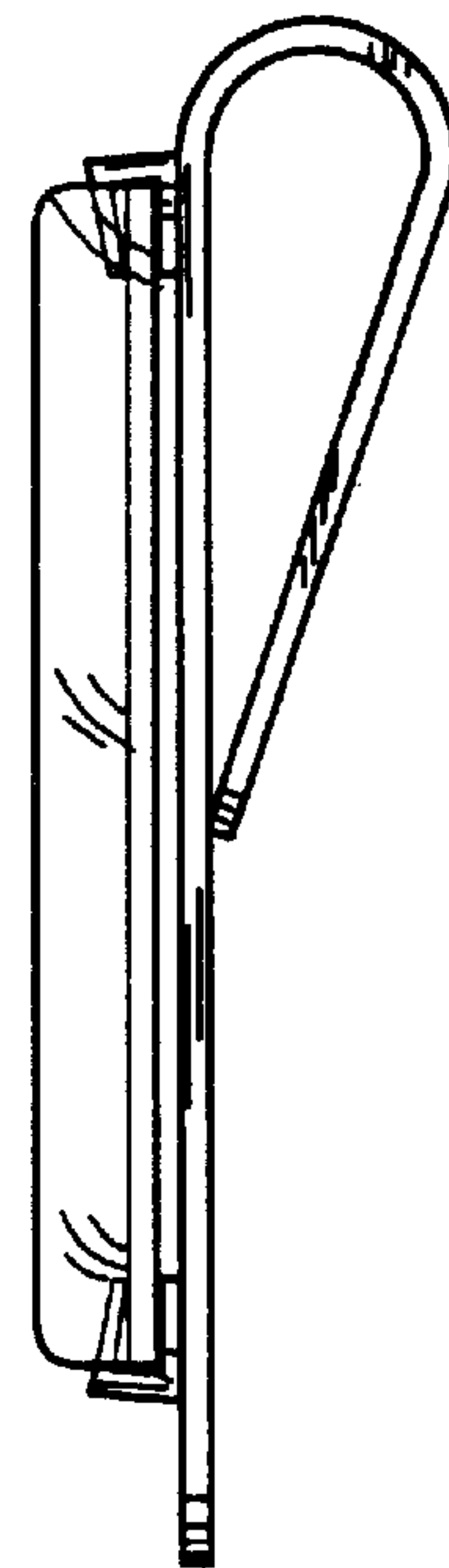

Fig. 14

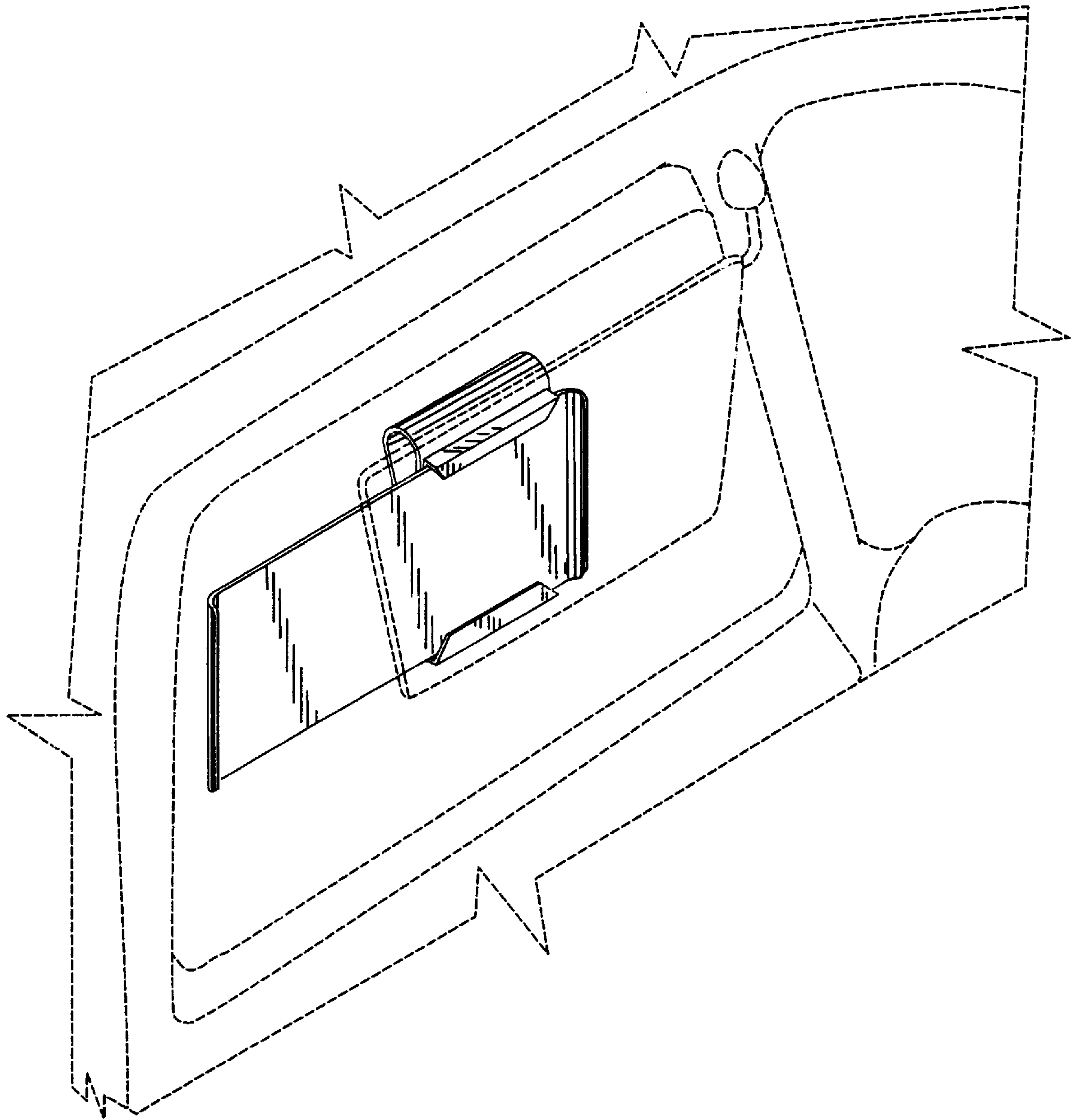

Fig. 15