



US00D426137S

# United States Patent [19]

Ball et al.

[11] Patent Number: Des. 426,137

[45] Date of Patent: \*\* Jun. 6, 2000

## [54] AUTOMOBILE ACCESSORY

## DESCRIPTION

[75] Inventors: **Gregg Ball**, Randolph, N.J.; **David Dennison**, Morristown, N.Y.

FIG. 1 is a perspective view of the first embodiment of an automobile accessory showing our new design;

[73] Assignee: **Allison Corporation**, Livingston, N.J.

FIG. 2 is a front view thereof;

[\*\*] Term: **14 Years**

FIG. 3 is a top view thereof;

[21] Appl. No.: **29/085,094**

FIG. 4 is a side view thereof, it being understood that the opposite is a mirror image thereof;

[22] Filed: **Mar. 16, 1998**

FIG. 5 is a bottom view thereof;

[51] **LOC (7) Cl.** ..... **08-06**

FIG. 6 is a top view of a second embodiment of an automobile accessory showing our new design;

[52] **U.S. Cl.** ..... **D8/305; D8/310; D12/400; D12/179**

FIG. 7 is a perspective view thereof;

[58] **Field of Search** ..... D12/400, 179, D12/190-192, 174, 153; D8/300, 305-310, 387; D21/41, 51, 232; D11/222-224, 238-240, 43-49; 292/347

FIG. 8 is a front view thereof, it being understood that the rear is mirror image thereof

FIG. 9 is a side view thereof, it being understood that the opposite is a mirror image thereof;

## [56] References Cited

FIG. 10 is a bottom view thereof;

FIG. 11 is a perspective view of a third embodiment of an automobile accessory showing our new design;

### U.S. PATENT DOCUMENTS

D. 214,981	8/1969	Nelson	.....	D12/153
D. 260,157	8/1981	Appel et al.	.....	D8/387
D. 319,297	8/1991	Hardman	.....	D8/305 X
D. 357,541	4/1995	Neidell	.....	D9/451 X
D. 400,422	11/1998	Dennison et al.	.....	D8/305
D. 401,197	11/1998	Julian	.....	D12/162
D. 402,599	12/1998	Adelaar	.....	D12/162
D. 404,696	1/1999	Julian	.....	D12/162

FIG. 12 is a top view thereof;

FIG. 13 is a front view thereof, it being understood that the rear side is a mirror image thereof;

### OTHER PUBLICATIONS

D & W Bestell Katalog, p. 817 See Items 1-4, 1994.  
Allison Auto Accessories, p. 53, See #8150 and #8117, 8127, 8128, and 8129, 1992.

FIG. 14 is a side view thereof, it being understood that the opposite is a mirror image thereof;

FIG. 15 is a bottom view thereof;

*Primary Examiner*—Doris V. Coles  
*Assistant Examiner*—Stacia Cadmus  
*Attorney, Agent, or Firm*—Helfgott & Karas P.C.

FIG. 16 is a perspective view of a fourth embodiment of an automobile accessory showing our new design;

FIG. 17 is a top view thereof;

FIG. 18 is a front view thereof, it being understood that the rear side is a mirror image thereof;

FIG. 19 is a side view thereof, it being understood that the opposite is a mirror image thereof; and,

FIG. 20 is a bottom view thereof.

The broken line showing of environment is for illustrative purposes only and forms no part of the claimed design.

## [57] CLAIM

The ornamental design for an automobile accessory, as shown and described.

1 Claim, 4 Drawing Sheets

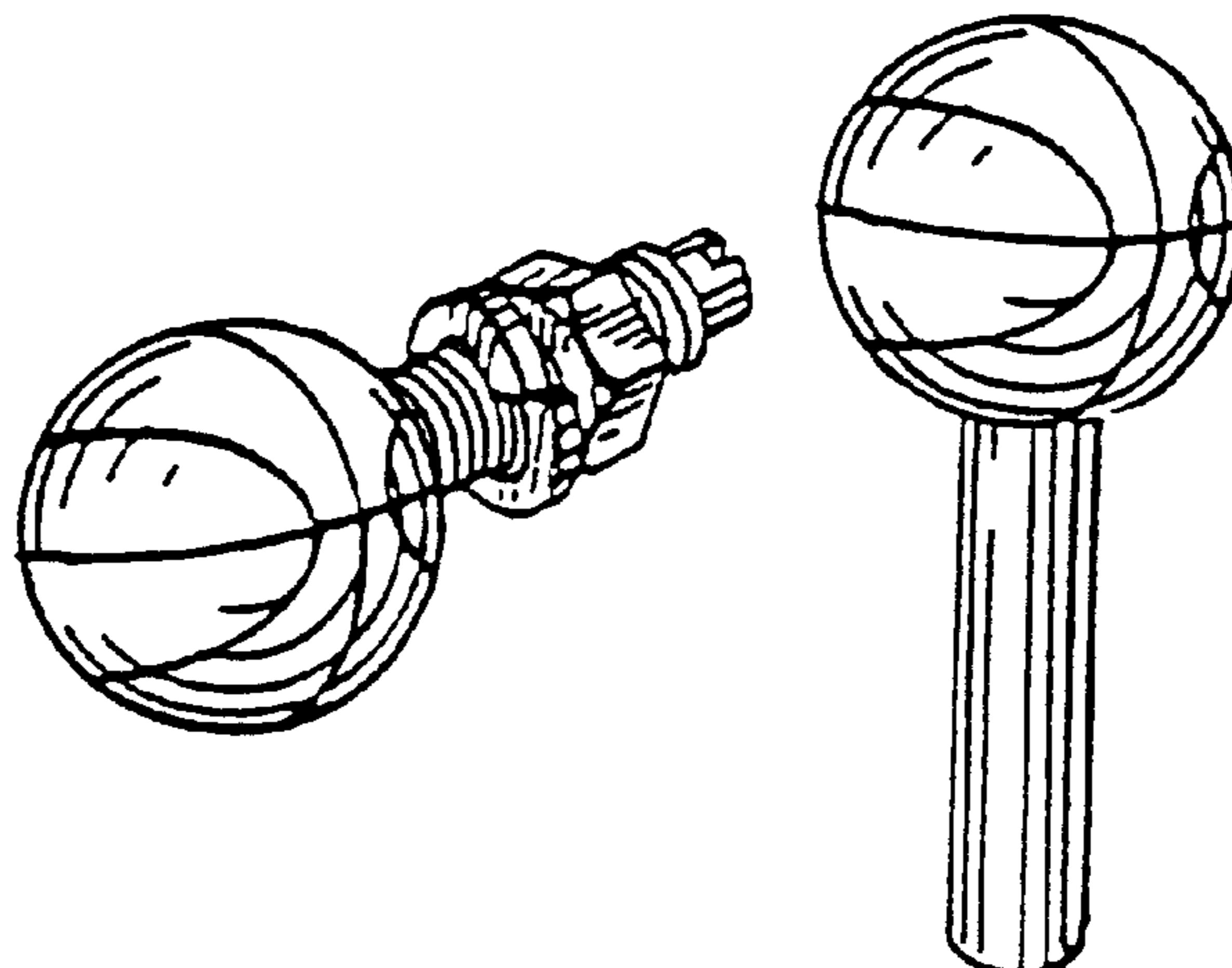

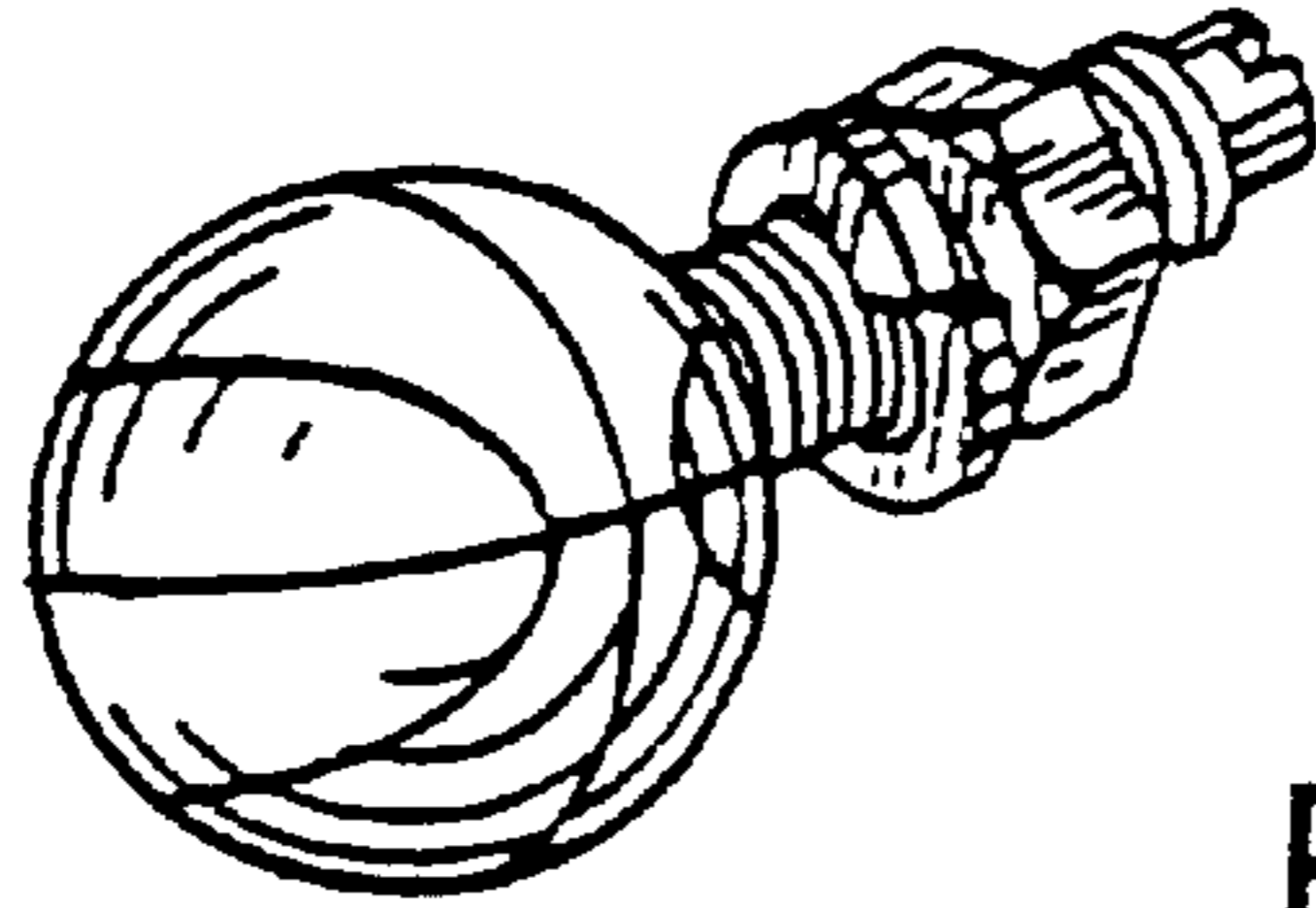

FIG. 1

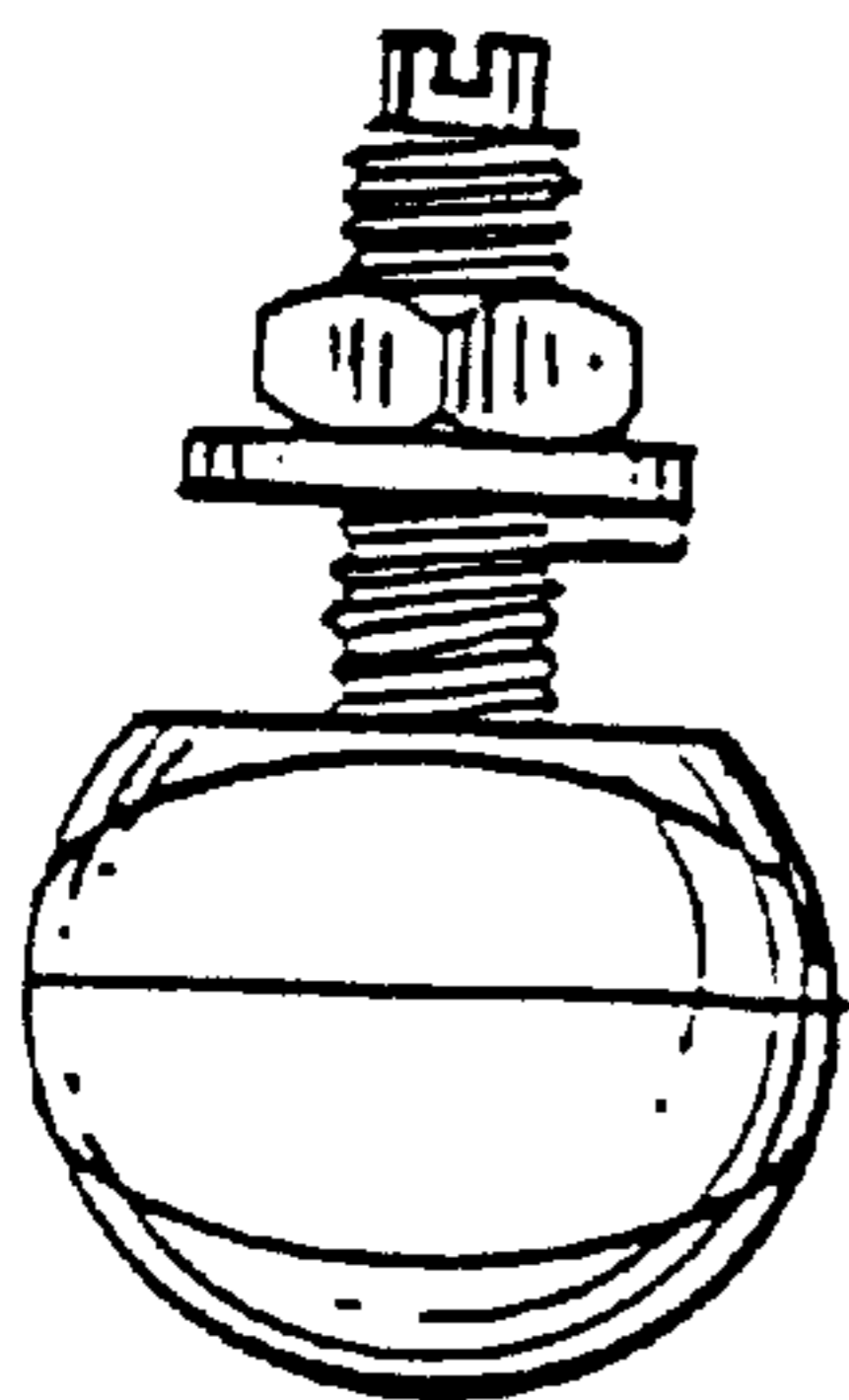

FIG. 2

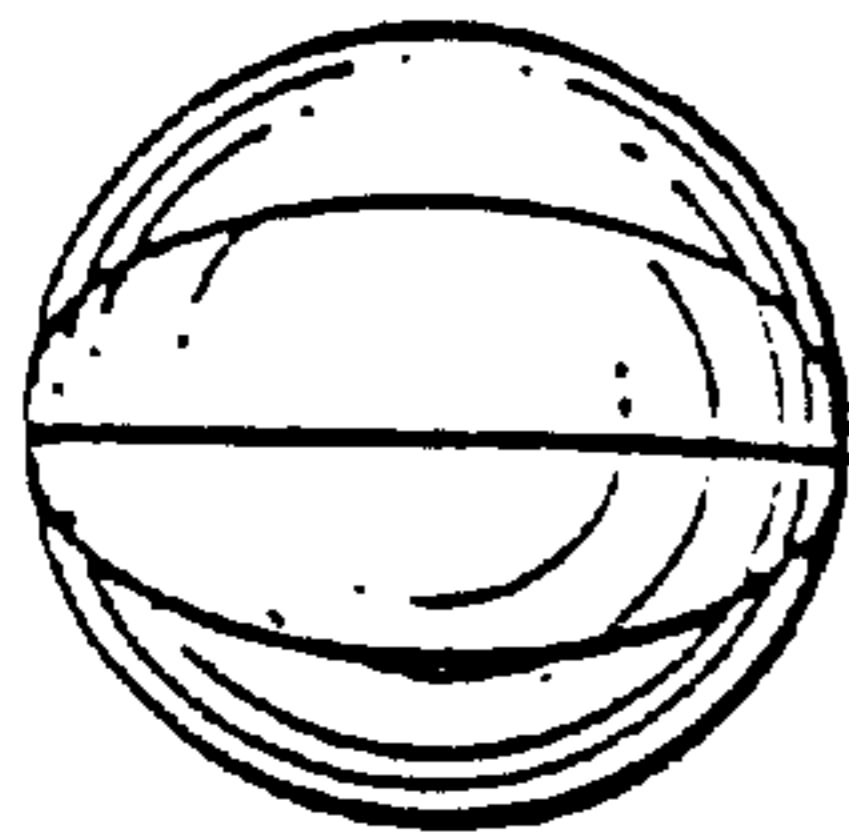

FIG. 3

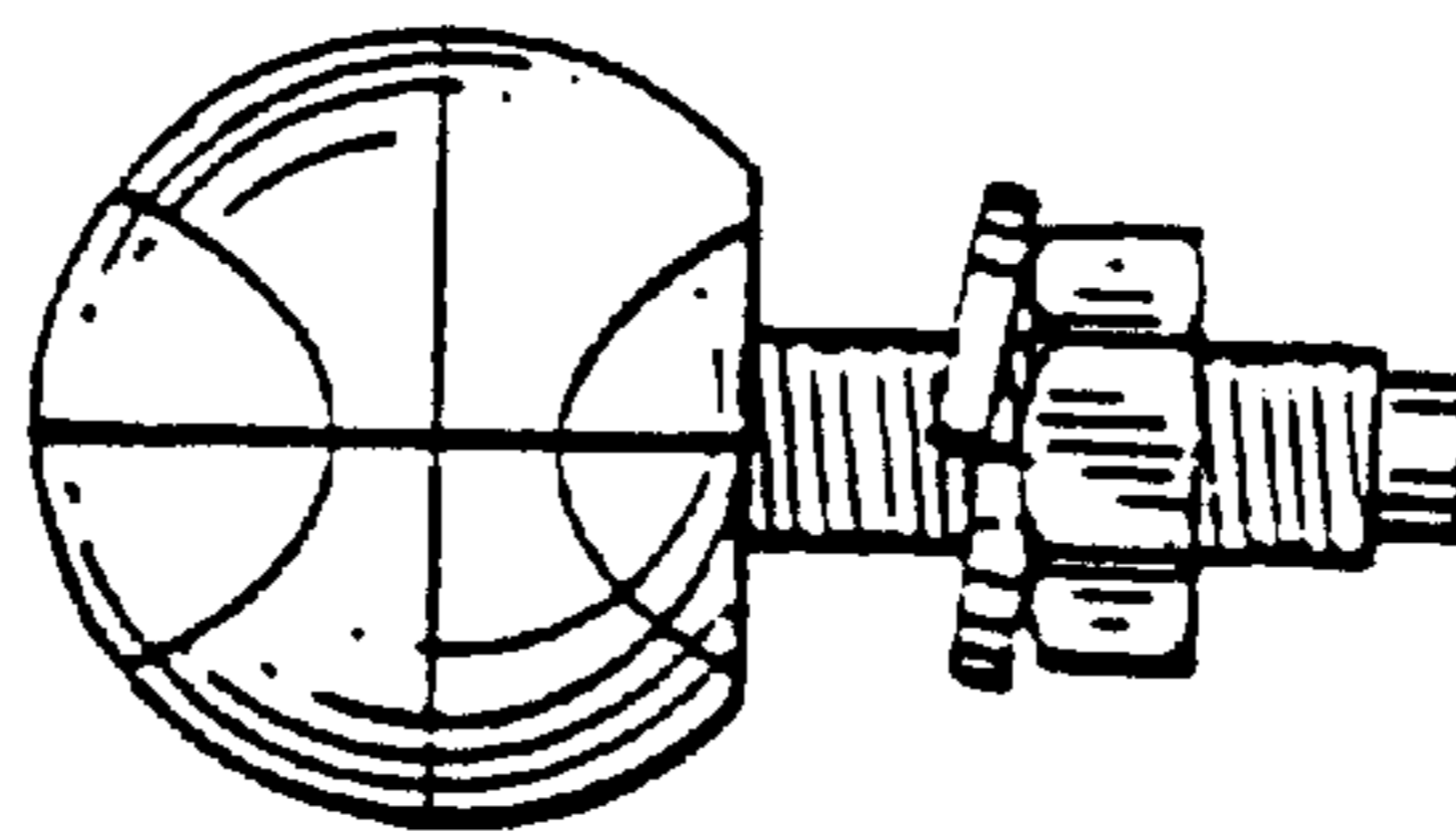

FIG. 4

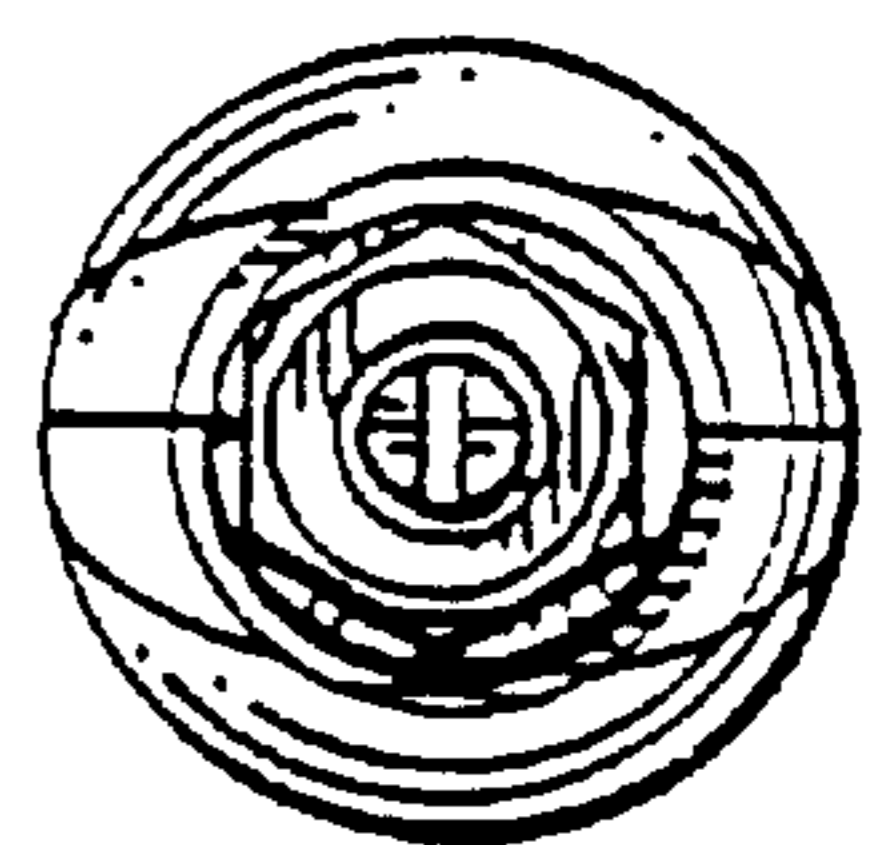

FIG. 5

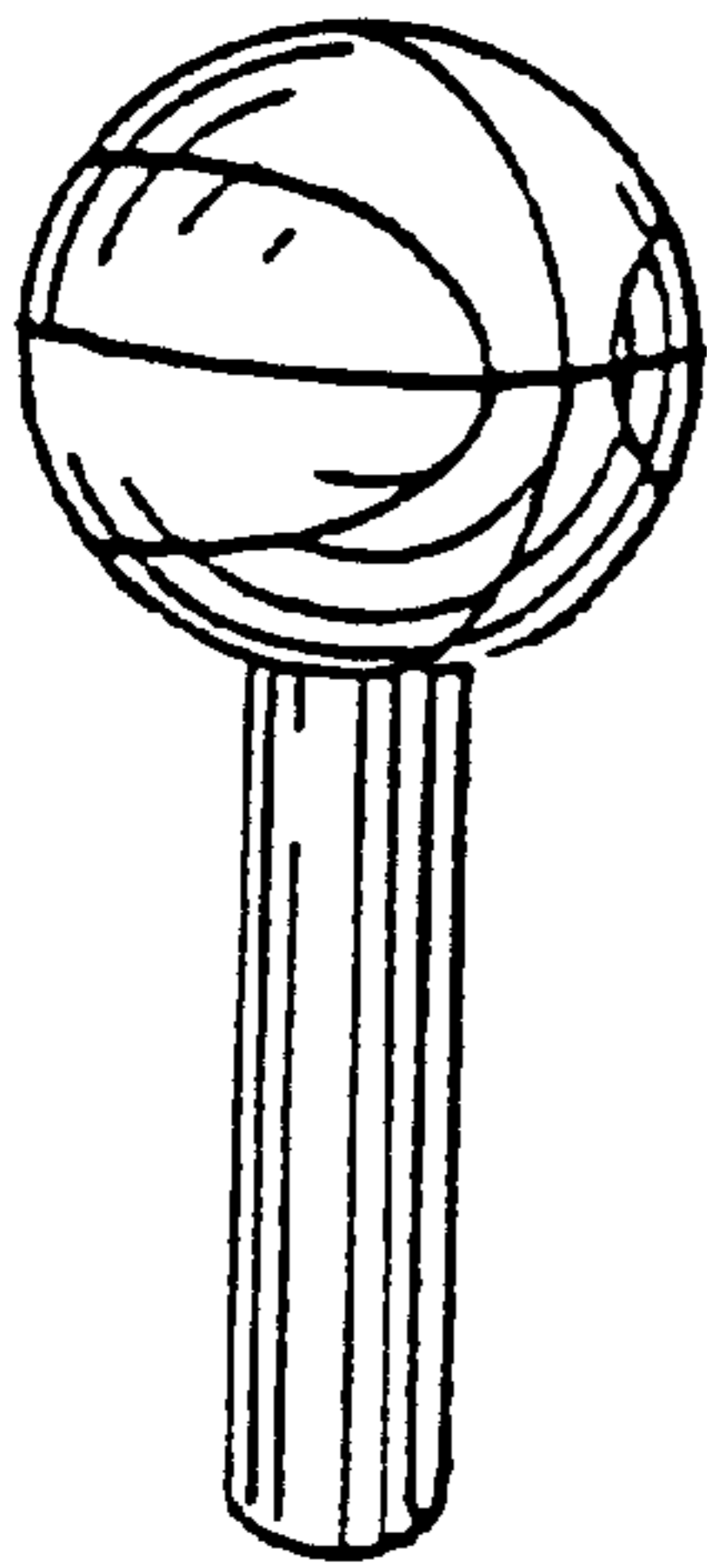

FIG. 7

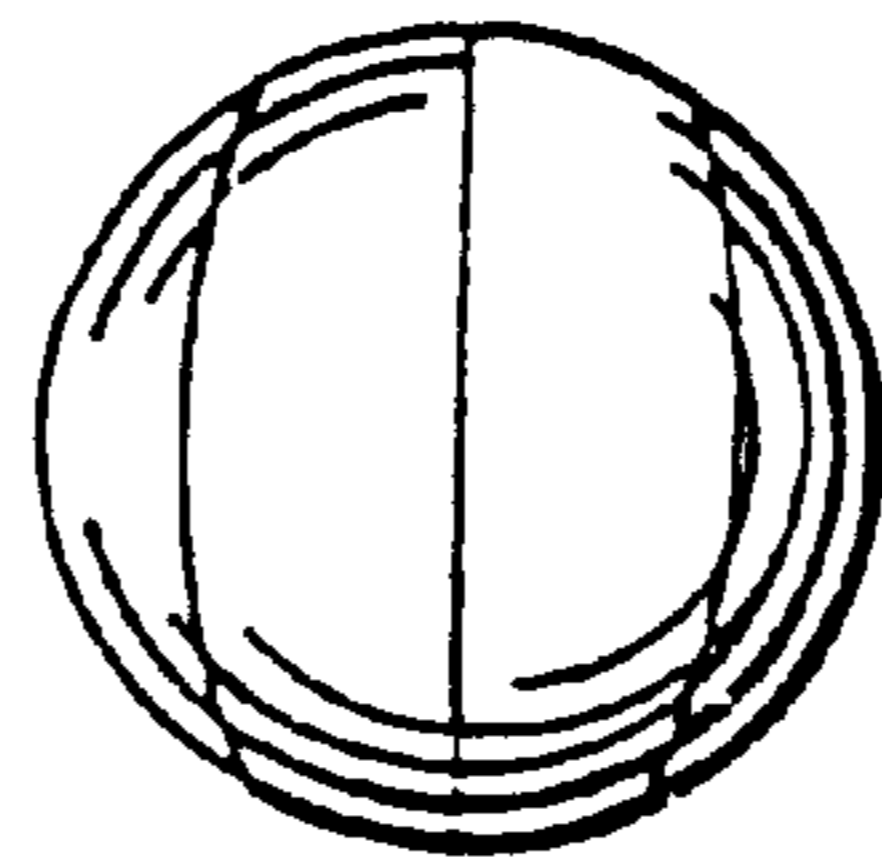

FIG. 6

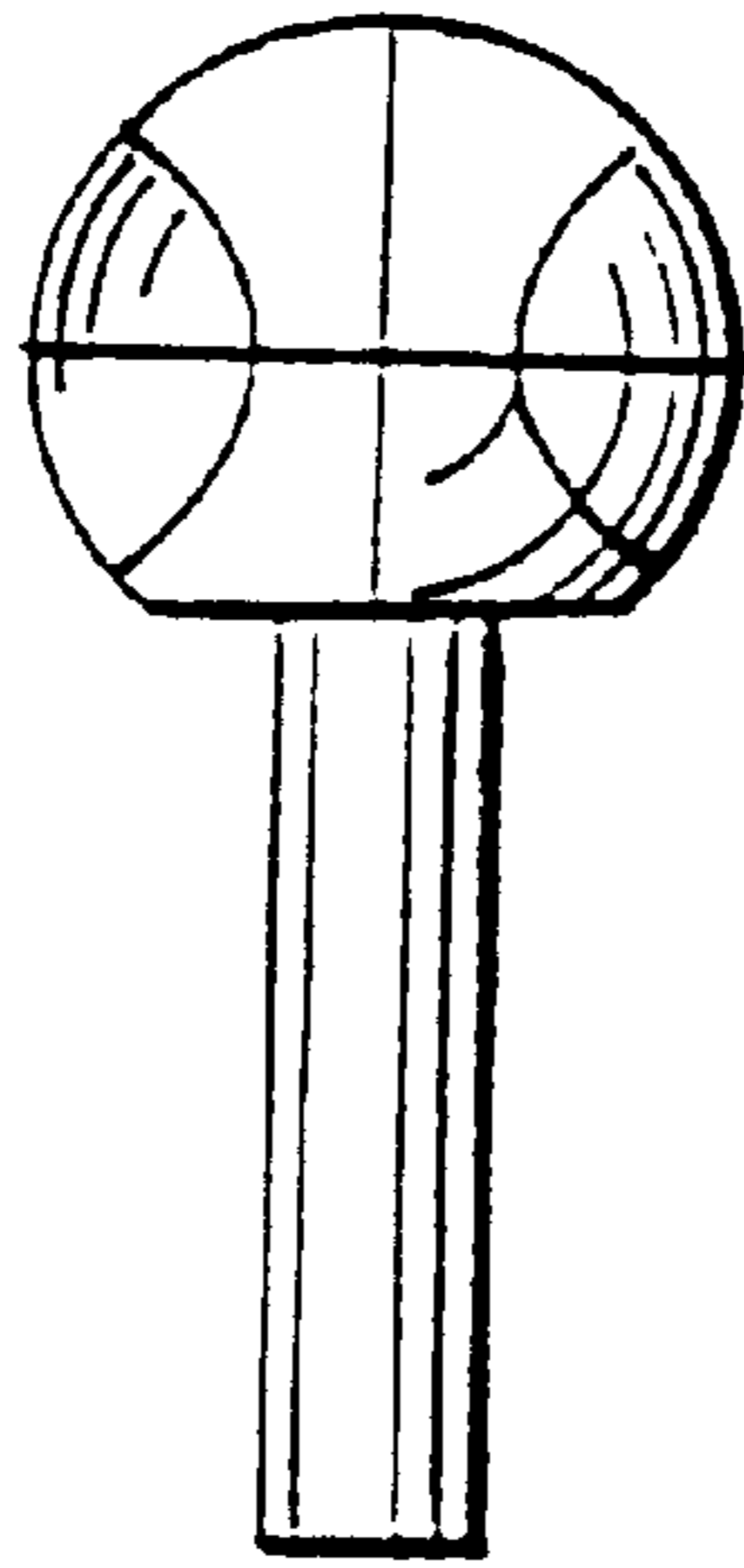

FIG. 8

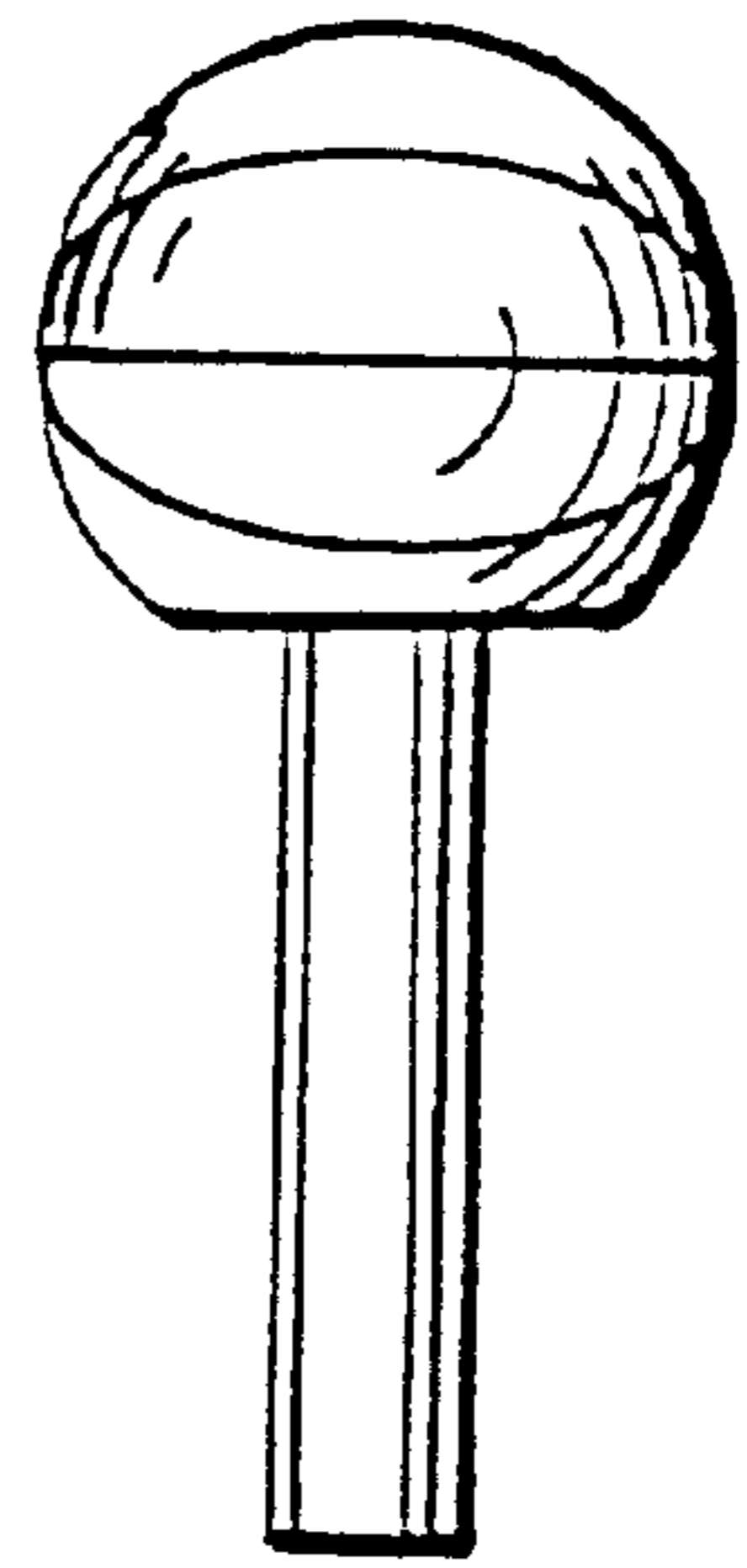

FIG. 9

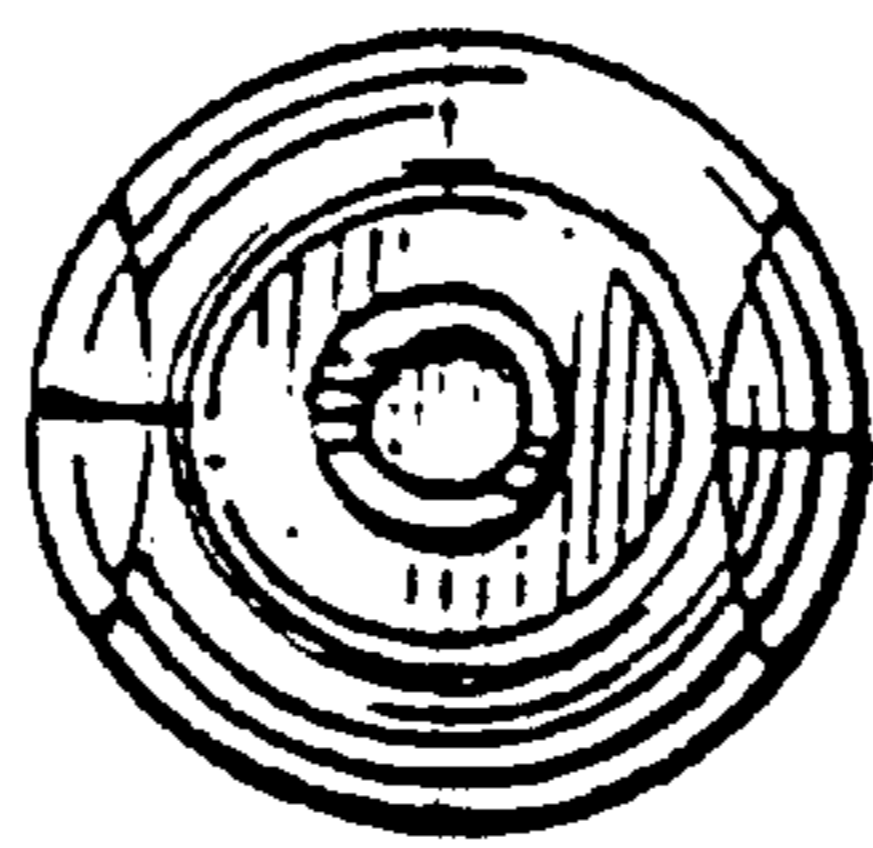

FIG. 10

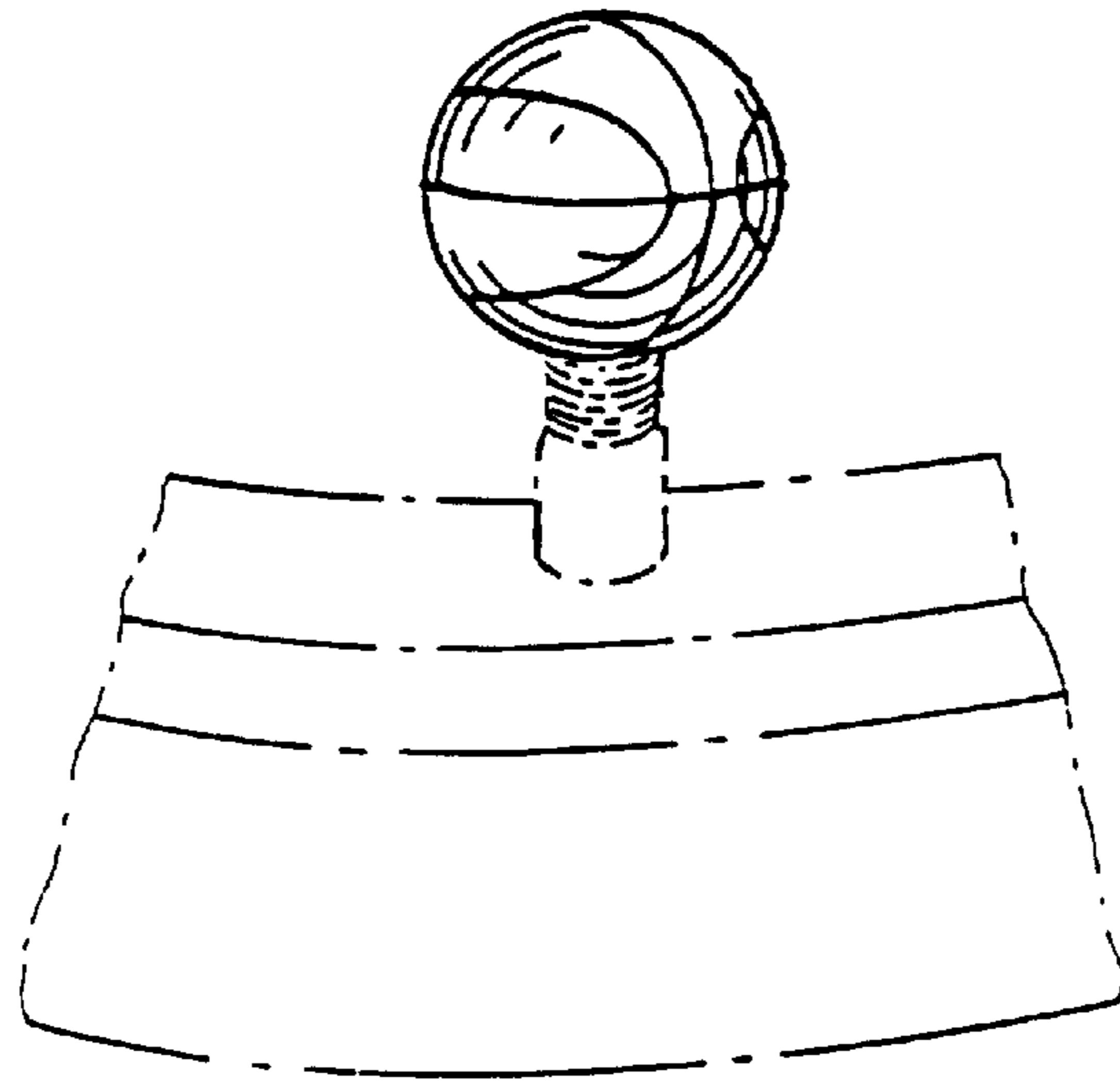

FIG. 11

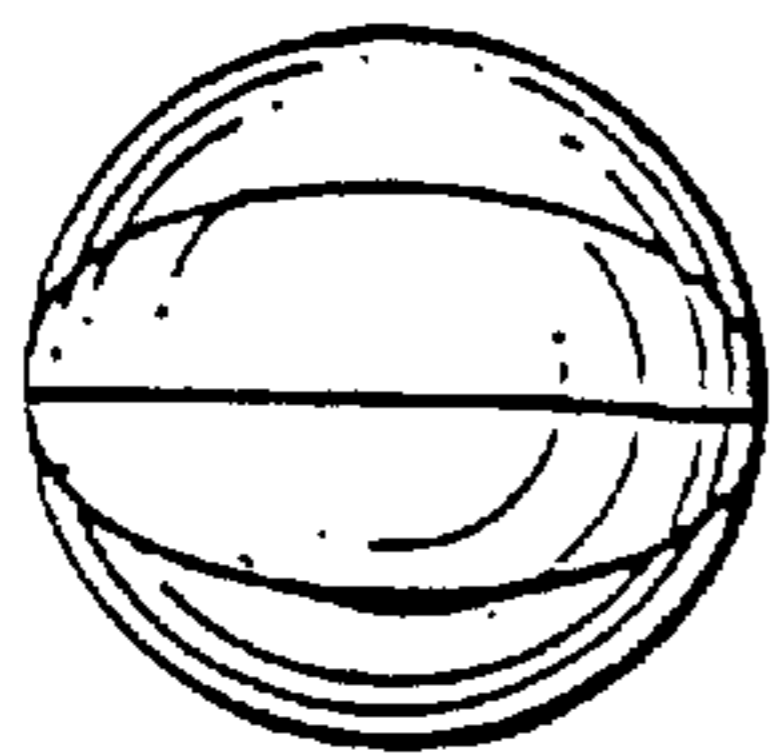

FIG. 12

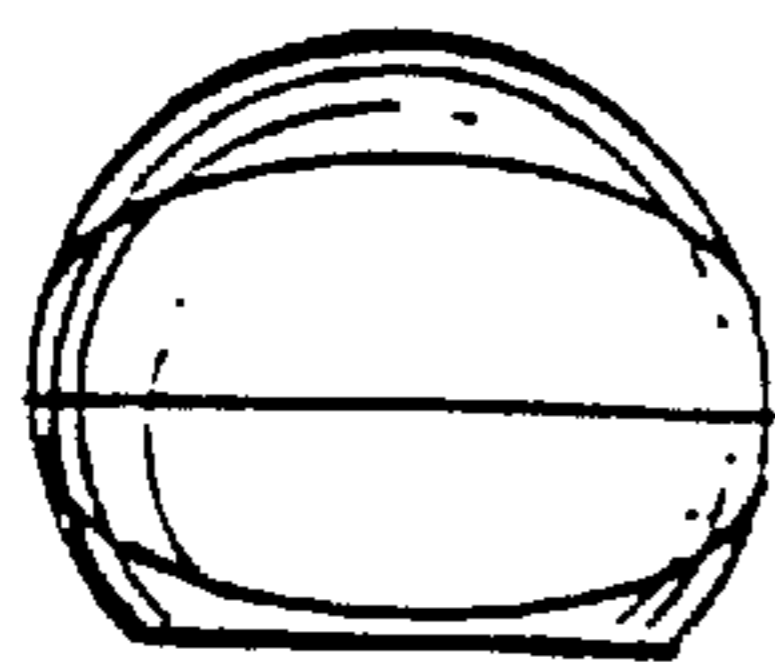

FIG. 13

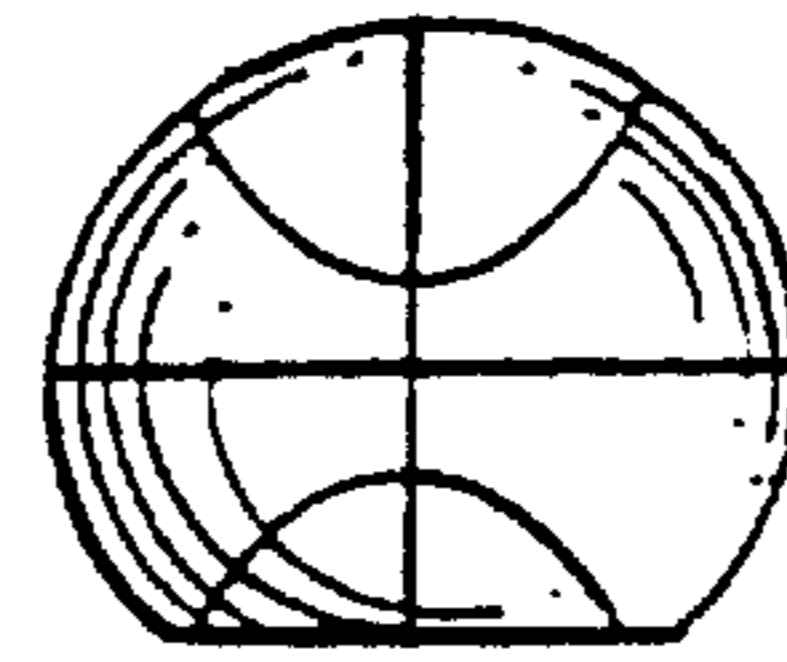

FIG. 14

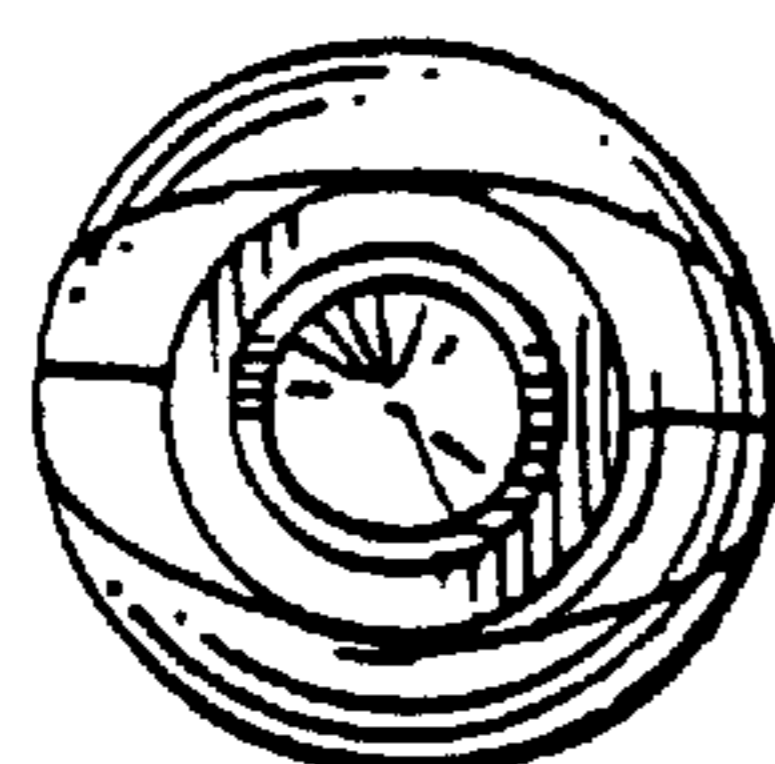

FIG. 15

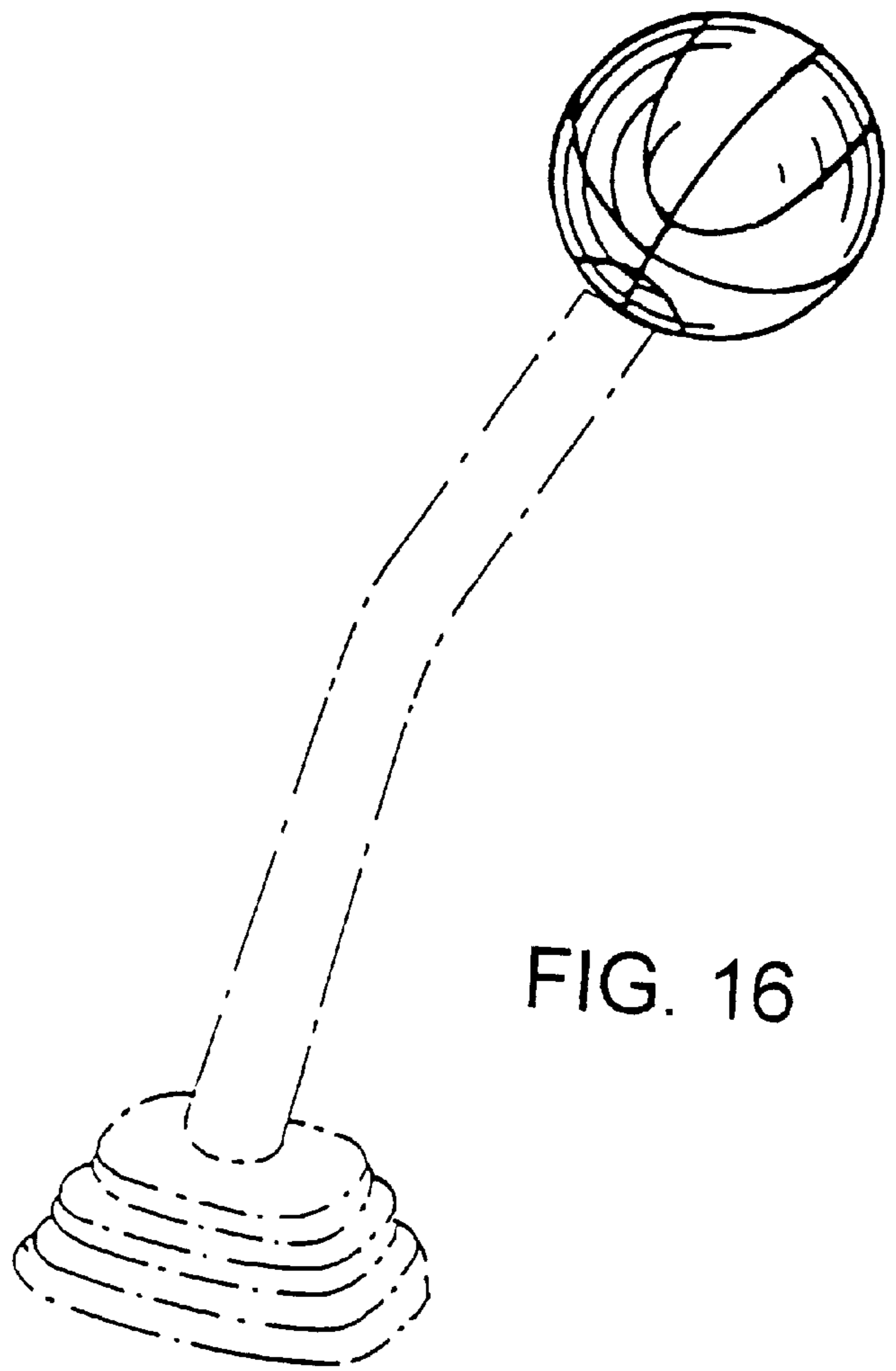

FIG. 16

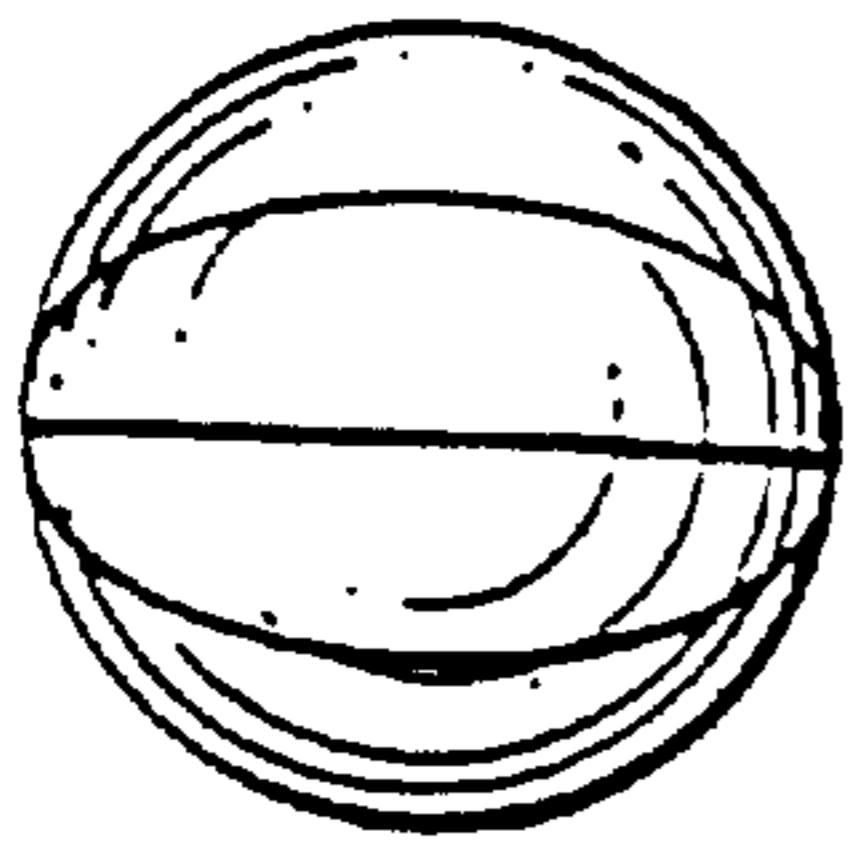

FIG. 17

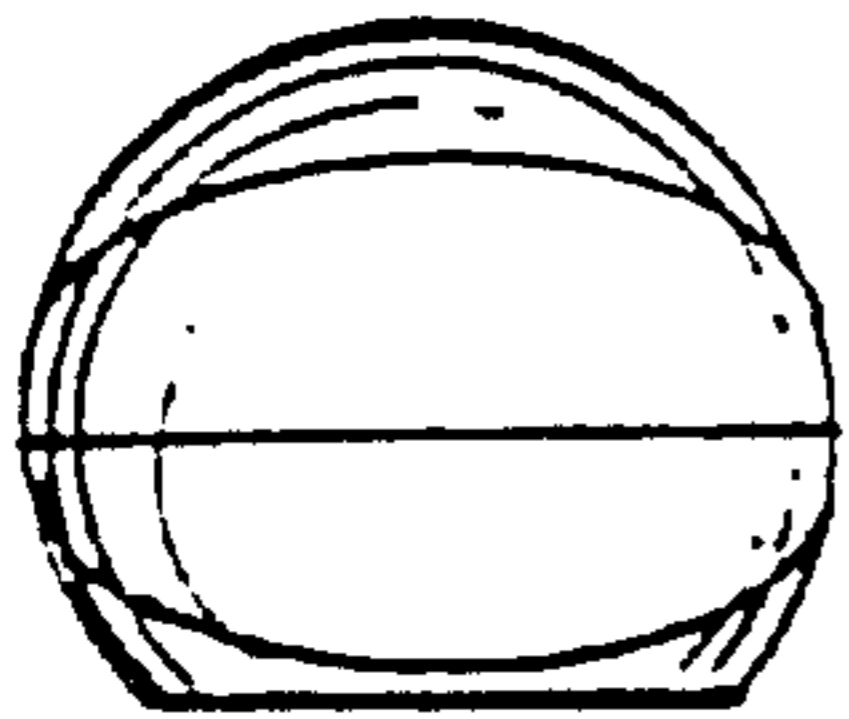

FIG. 18

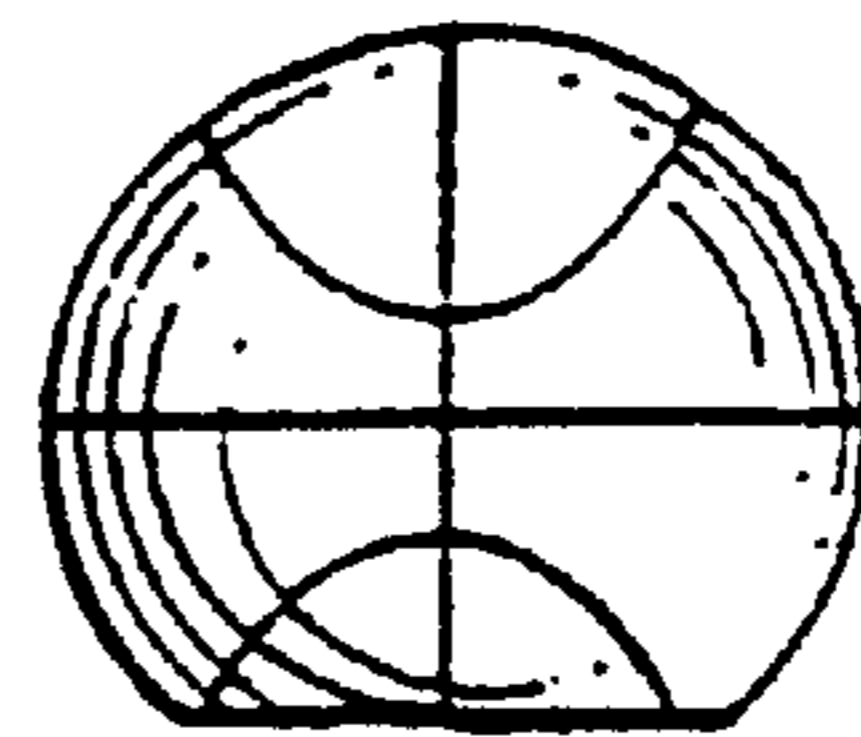

FIG. 19

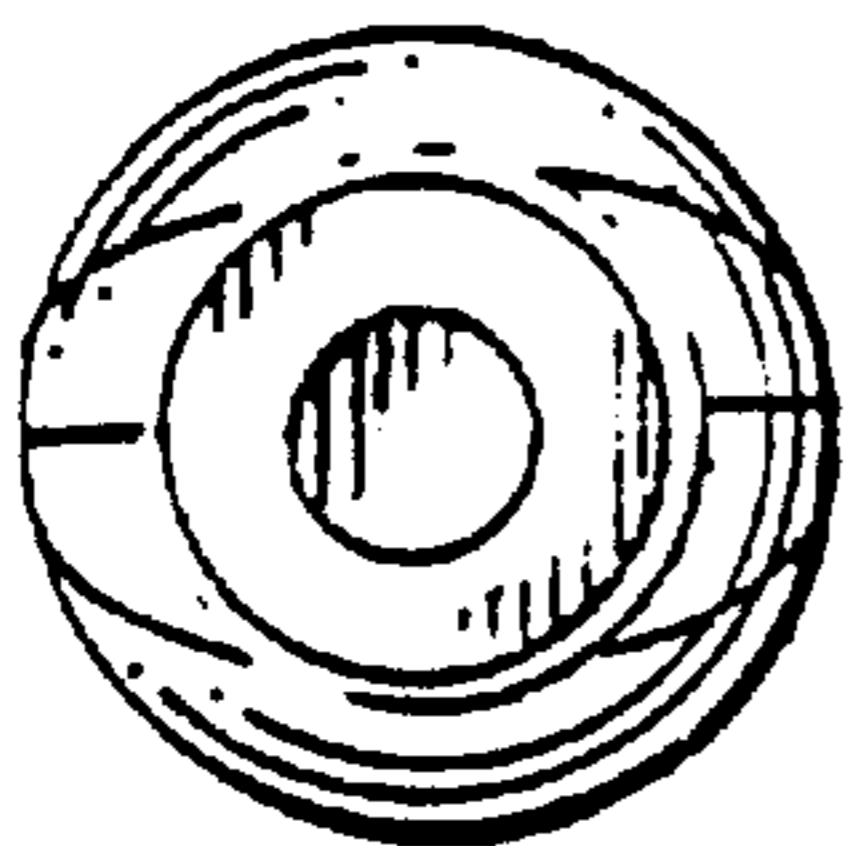

FIG. 20