



US00D425853S

United States Patent [19] Caporaletti

[11] **Patent Number: Des. 425,853**

[45] **Date of Patent: ** May 30, 2000**

[54] **HELICOPTER**

5,377,934 1/1995 Hill 244/17.11

[75] Inventor: **Amedeo Caporaletti**, Mogliano Veneto, Italy

Primary Examiner—Kay H. Chin
Attorney, Agent, or Firm—Pitney, Hardin, Kipp & Szuch, LLP

[73] Assignee: **Finmeccanica S.p.A.**, Rome, Italy

[57] **CLAIM**

[**] Term: **14 Years**

The ornamental design for a helicopter, as shown and described.

[21] Appl. No.: **29/095,046**

[22] Filed: **Oct. 15, 1998**

DESCRIPTION

[30] **Foreign Application Priority Data**

Apr. 17, 1998 [IT] Italy TO9800103

FIG. 1 is a side elevational view of a helicopter showing my design;

[51] **LOC (7) Cl.** **12-07**

[52] **U.S. Cl.** **D12/327; D12/328**

FIG. 2 is an opposed side elevational view thereof;

FIG. 3 is a top plan view thereof;

FIG. 4 is a bottom plan view thereof;

FIG. 5 is a front elevational view thereof; and,

FIG. 6 is a rear elevational view thereof.

[58] **Field of Search** D12/319, 326, D12/327, 328, 329; 244/17.11, 17.19, 17.21

The characteristic feature of the design resides in a helicopter having a lateral stripe on each of its sides that extends from the nose end along each side up to the bottom fin and then to the tail skid at which location the strip blends and combines with the profile of the tail skid.

[56] **References Cited**

U.S. PATENT DOCUMENTS

D. 239,710 4/1976 Garrison D12/327

D. 361,053 8/1995 Whyte et al. D12/327

1 Claim, 5 Drawing Sheets

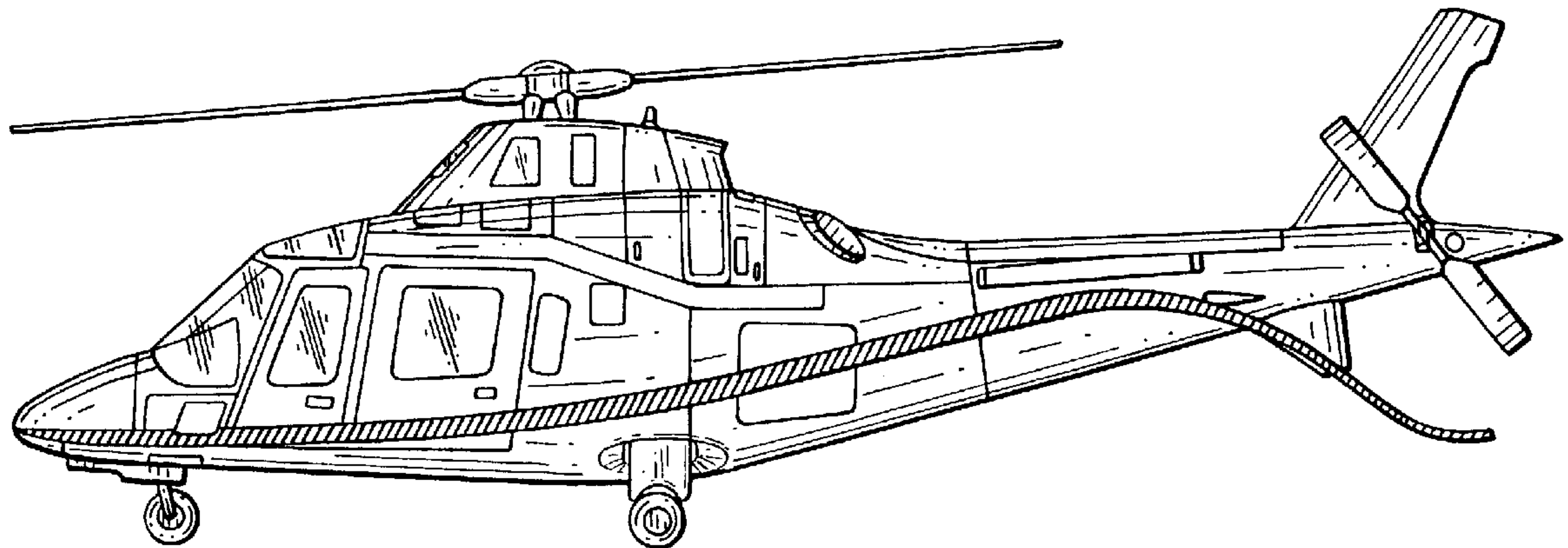

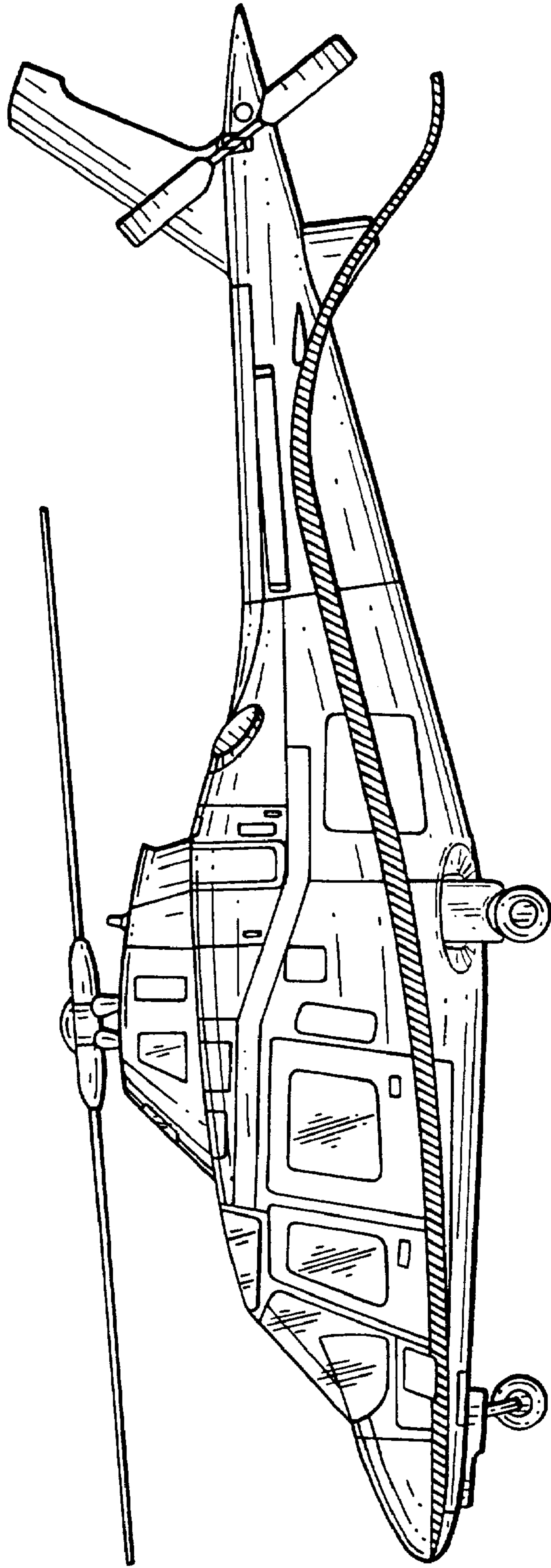

FIG. 1

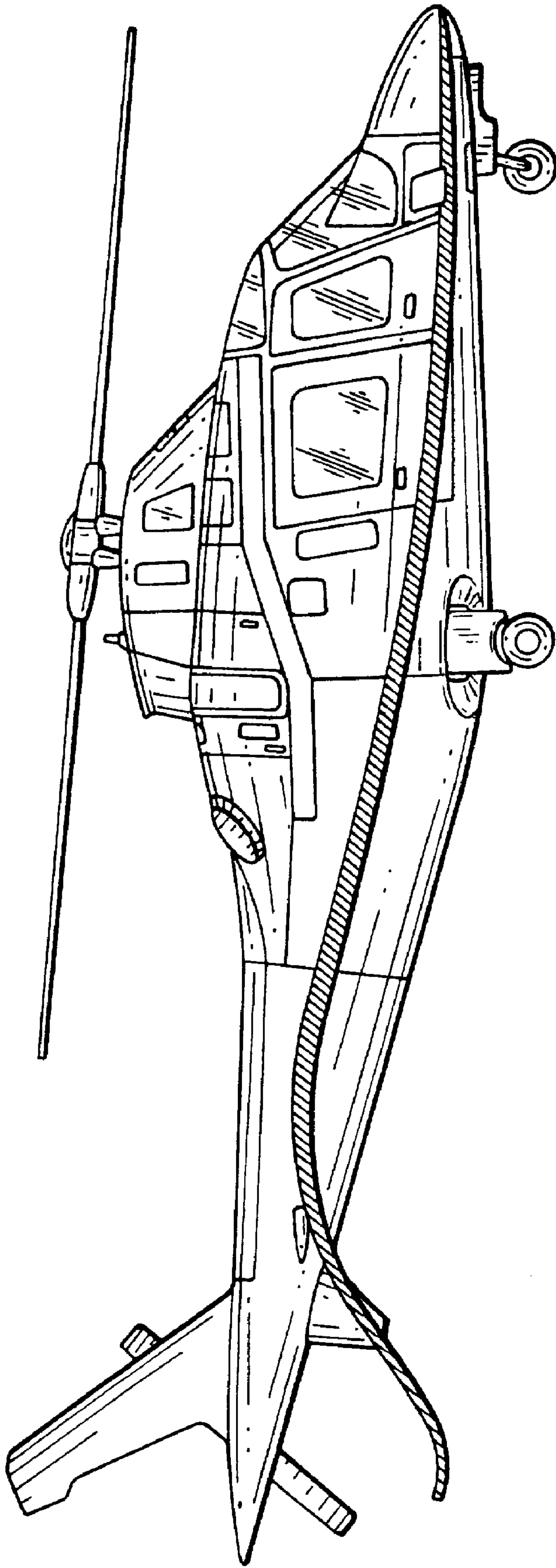

FIG. 2

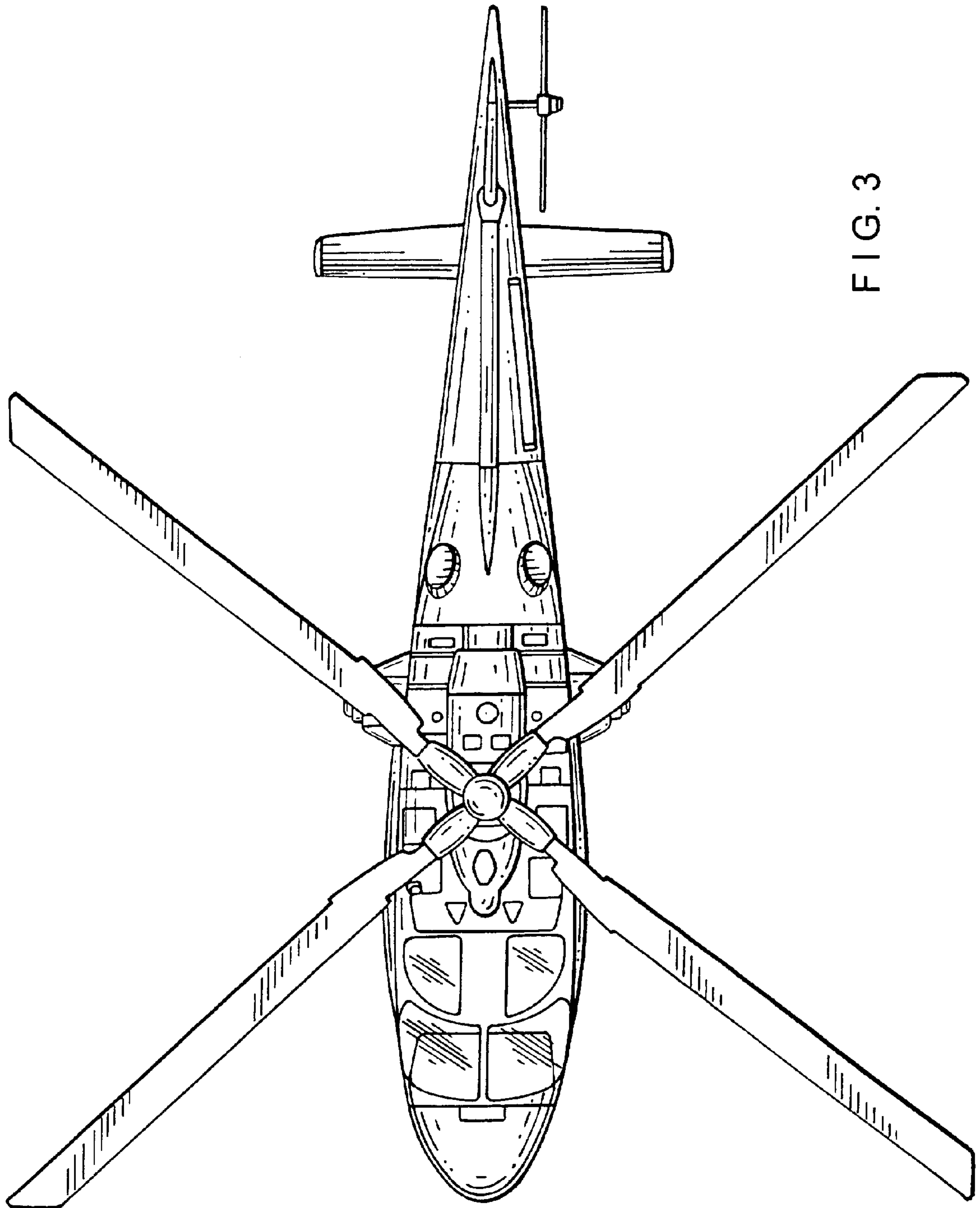

FIG. 3

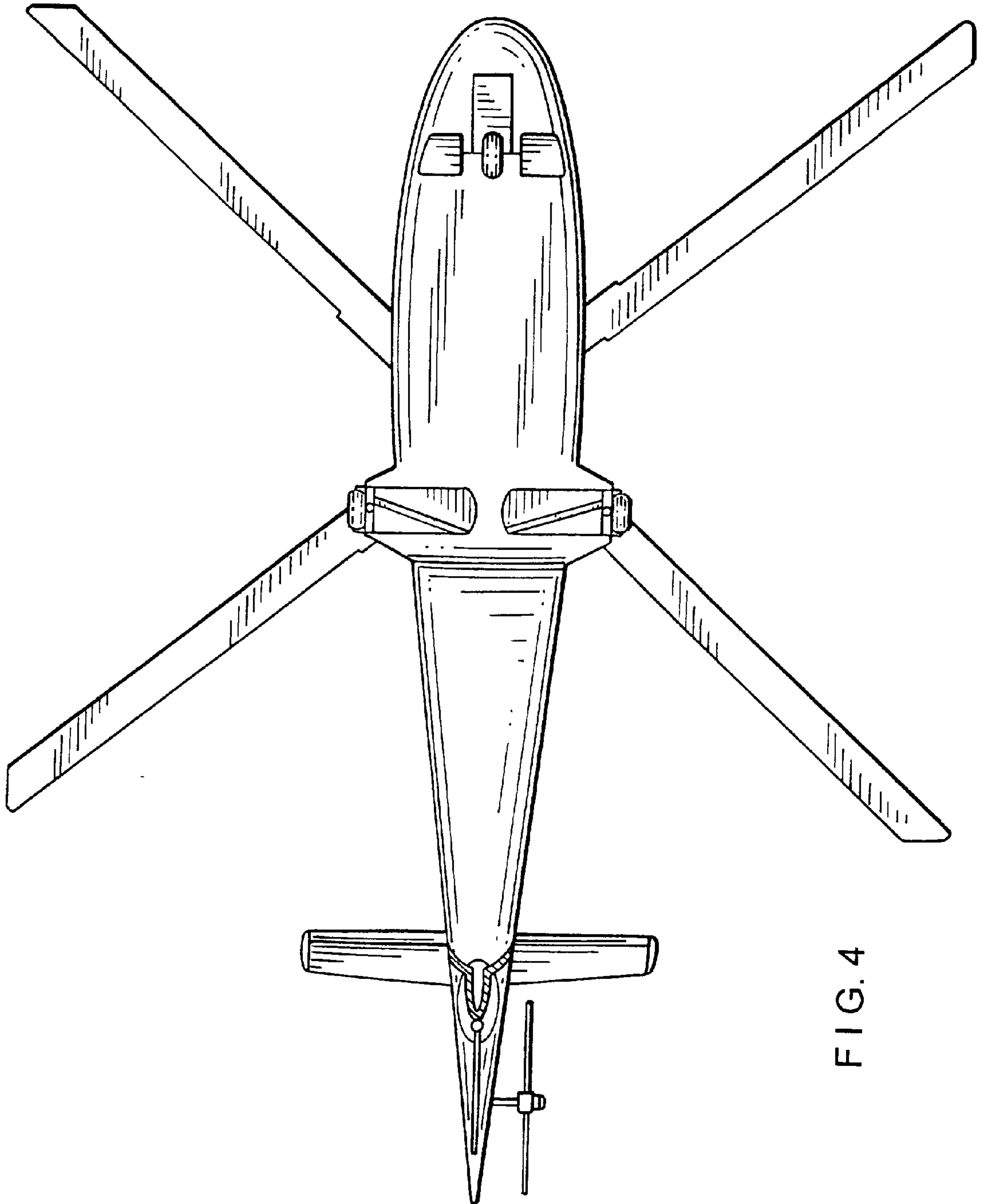

FIG. 4

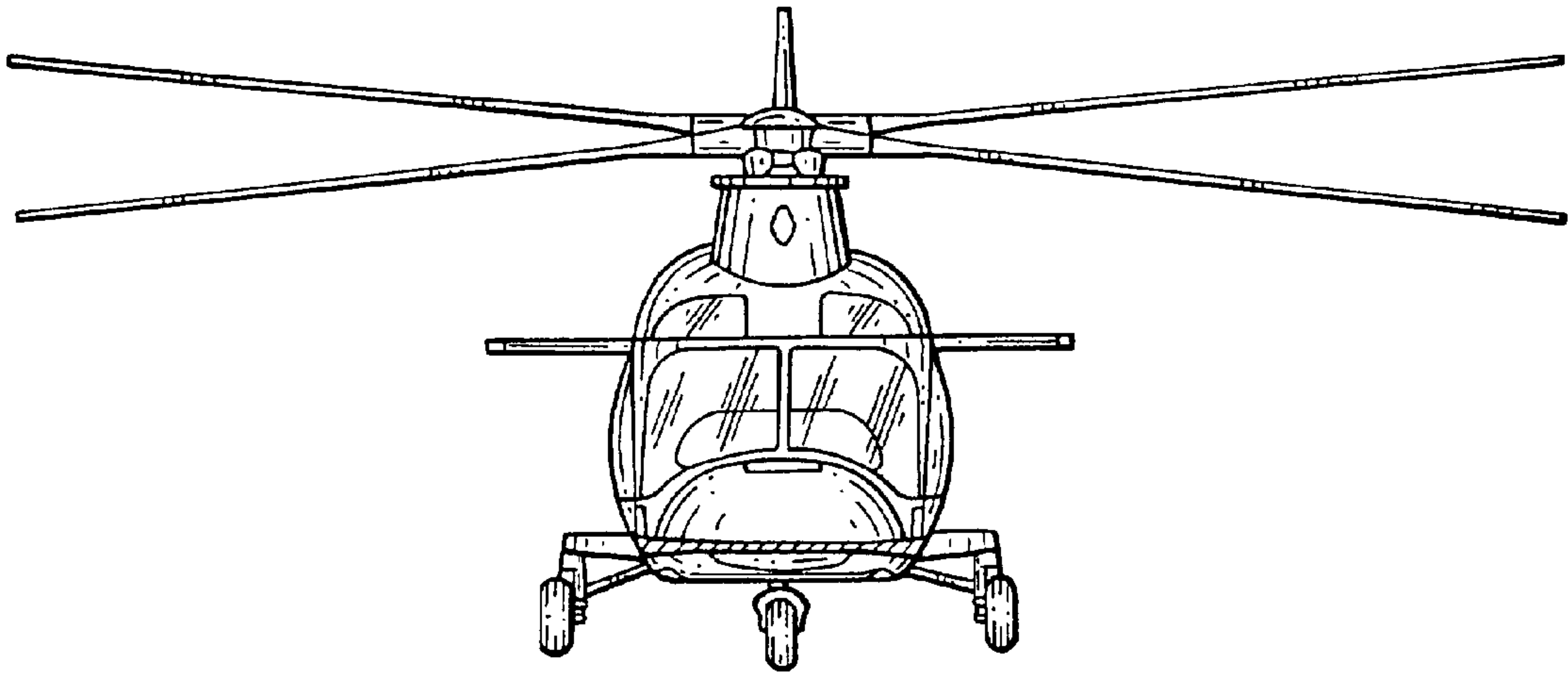

FIG. 5

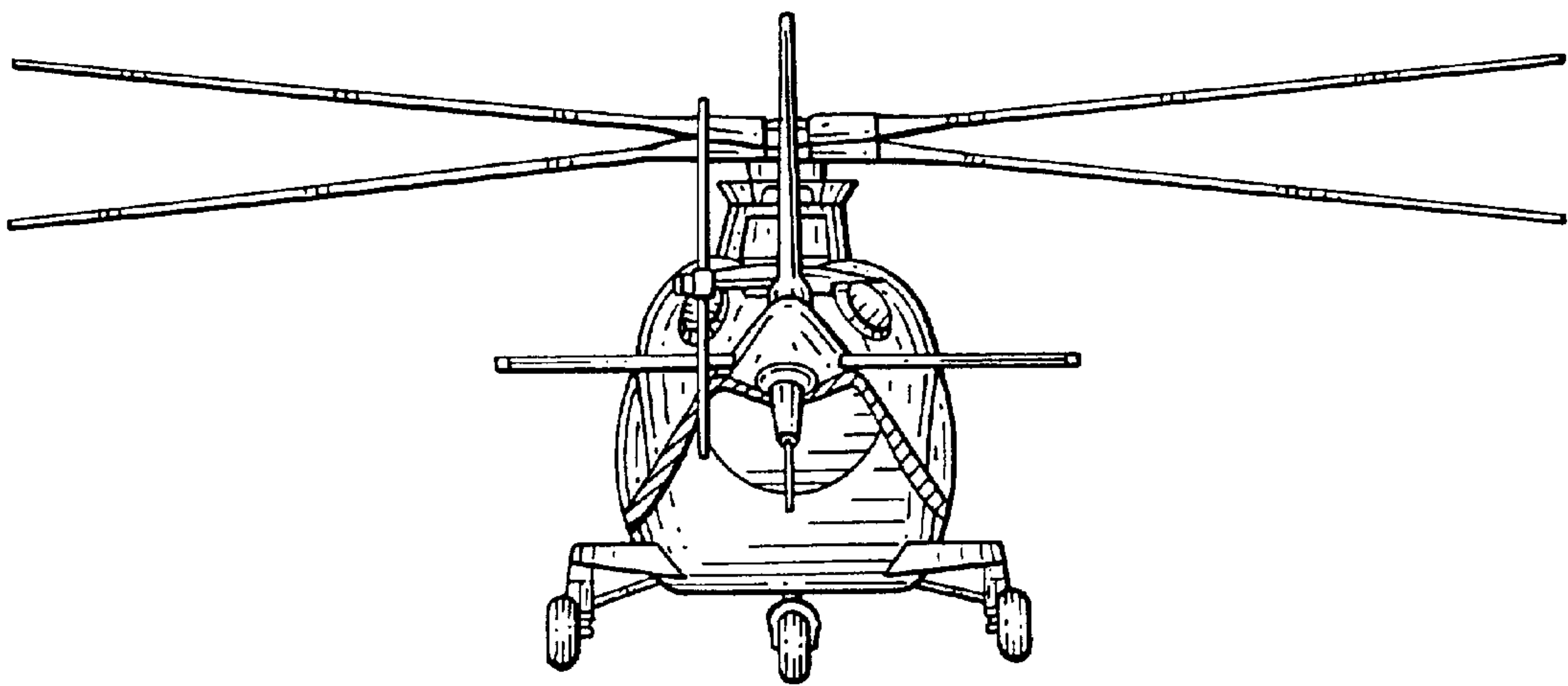

FIG. 6