



US00D425840S

**United States Patent** [19]  
**Hare**

[11] **Patent Number: Des. 425,840**

[45] **Date of Patent: \*\* May 30, 2000**

[54] **EMERGENCY STEERING WHEEL COLUMN DEFLECTOR**

D. 411,821 7/1999 Markegard et al. .... D12/177  
5,996,736 12/1999 Stankiewicz ..... 70/209 X

[76] Inventor: **Thomas D. Hare**, Rte. 2, Box 175,  
Wynne, Ark. 72396

*Primary Examiner*—Melody N. Brown  
*Attorney, Agent, or Firm*—Stephen D. Carver

[\*\*] Term: **14 Years**

[57] **CLAIM**

[21] Appl. No.: **29/106,819**

The ornamental design for an emergency steering wheel column deflector, as shown.

[22] Filed: **Jun. 21, 1999**

**DESCRIPTION**

[51] **LOC (7) Cl.** ..... **12-16**

[52] **U.S. Cl.** ..... **D12/177**

[58] **Field of Search** ..... D12/177; D8/333,  
D8/331; 74/558, 558.5; 70/209, 232, 225,  
236, 238, 226, 227; 182/127

FIG. 1 is a front elevational view of an emergency steering wheel column deflector showing my new design;  
FIG. 2 is a rear elevational view thereof;  
FIG. 3 is a bottom plan view thereof;  
FIG. 4 is a top plan view thereof;  
FIG. 5 is a right side elevational view thereof; and,  
FIG. 6 is a front perspective view thereof.

[56] **References Cited**

**U.S. PATENT DOCUMENTS**

D. 265,645 8/1982 Hampton ..... D12/162

**1 Claim, 6 Drawing Sheets**

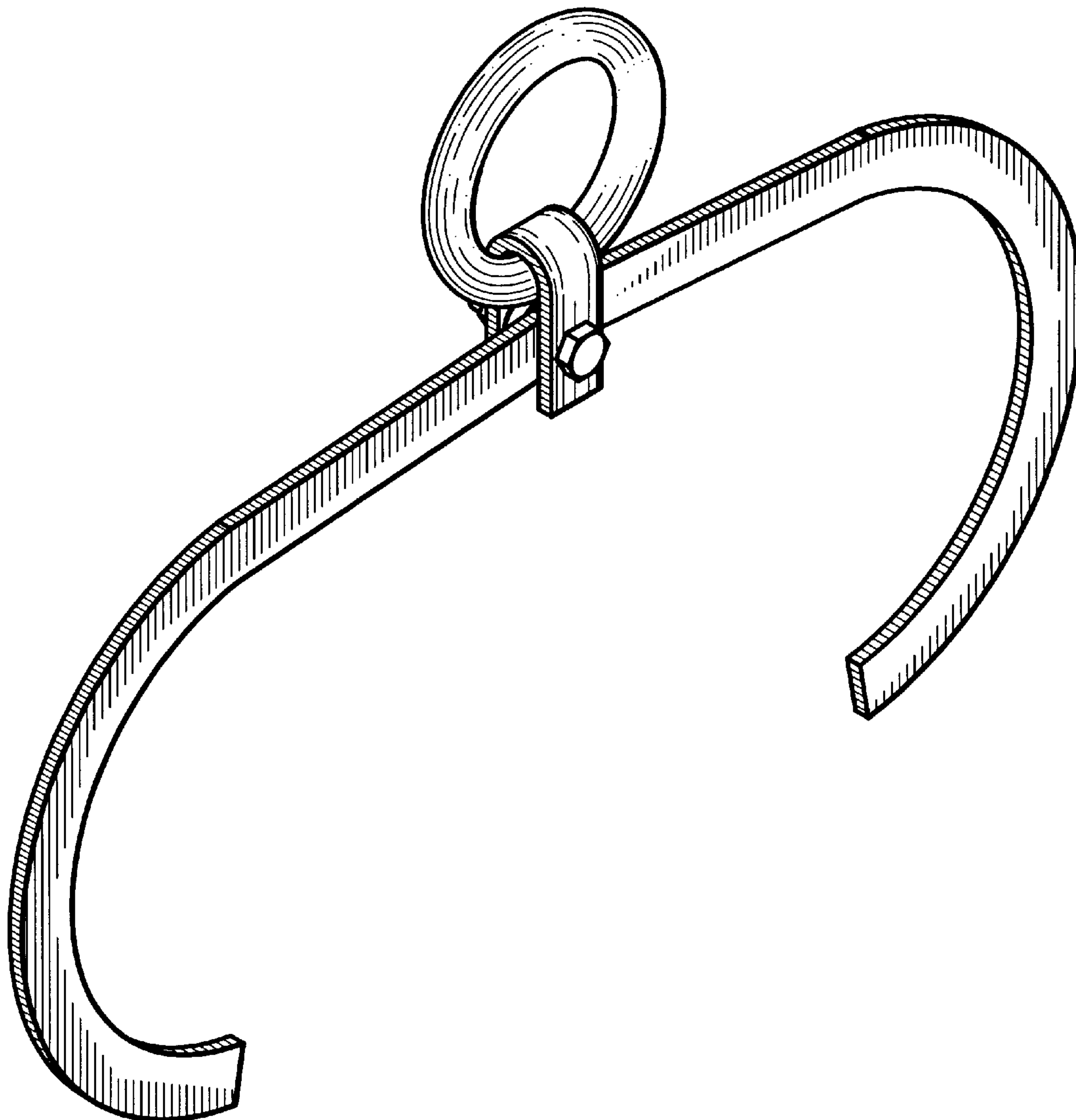

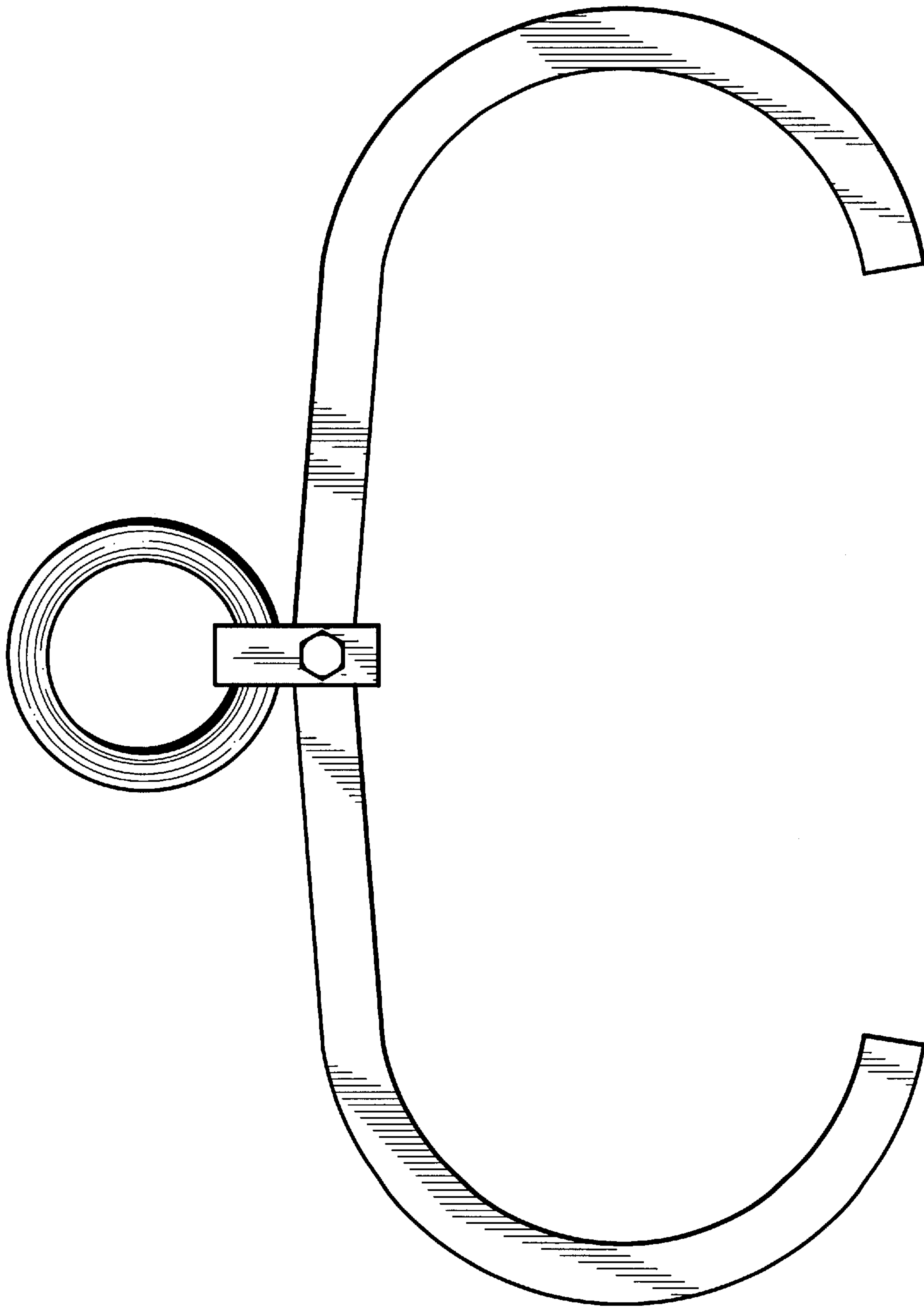

Fig. 1

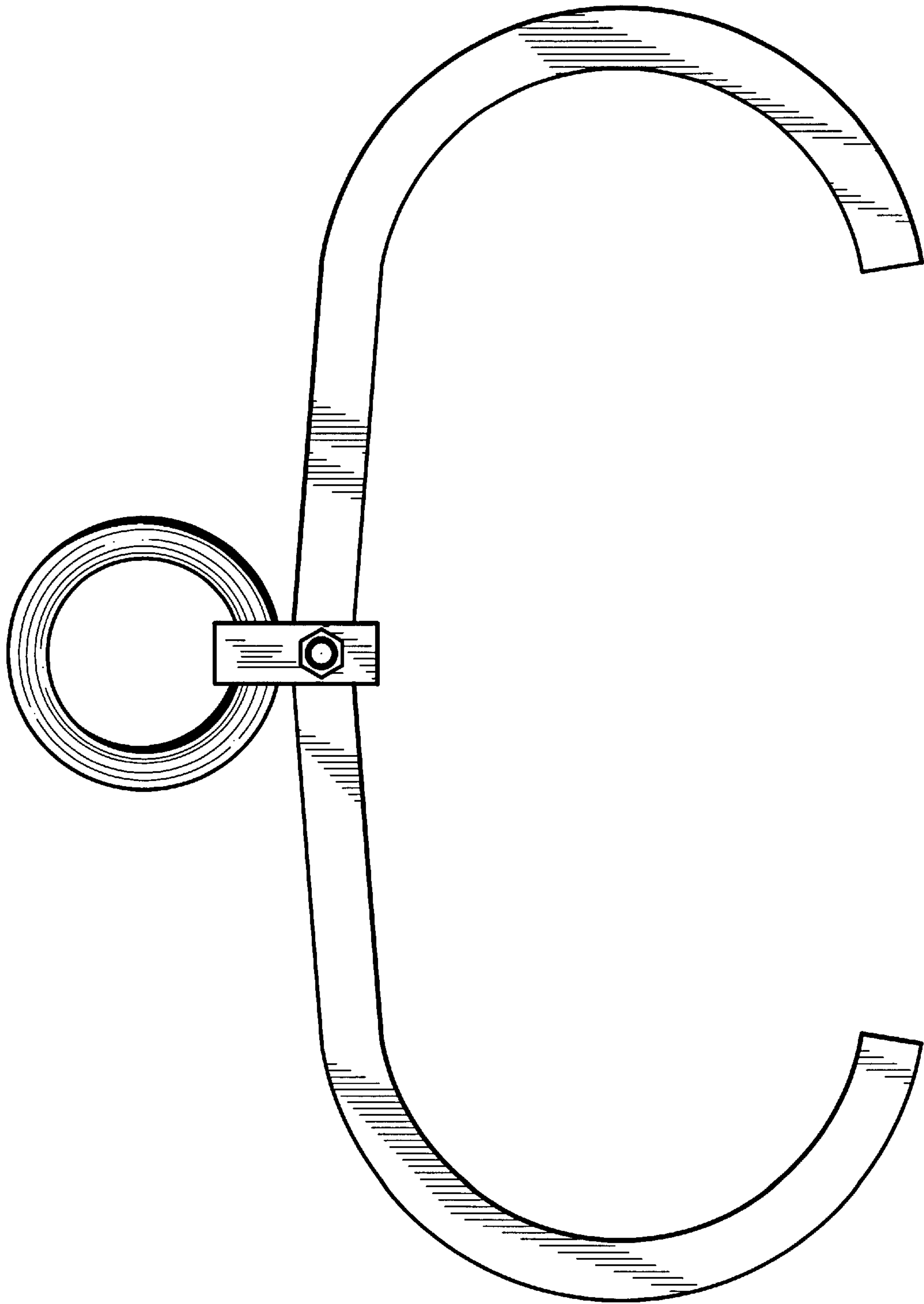

Fig. 2

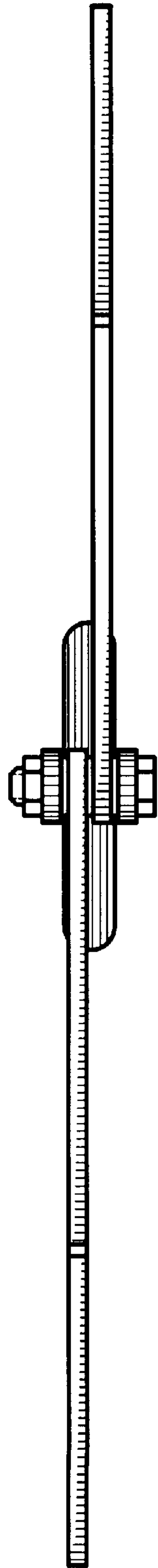

Fig. 3

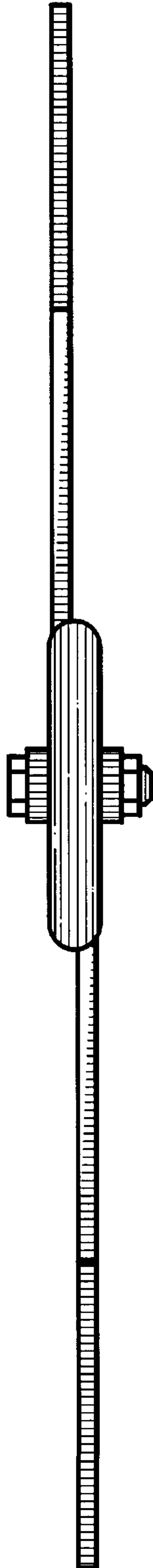

FIG. 4

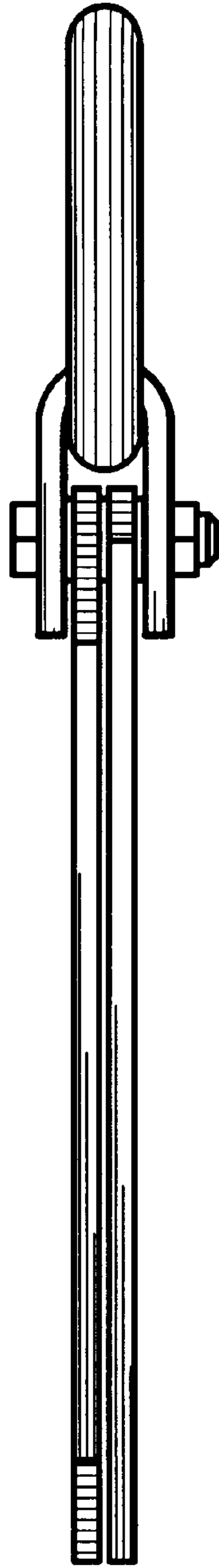

Fig. 5

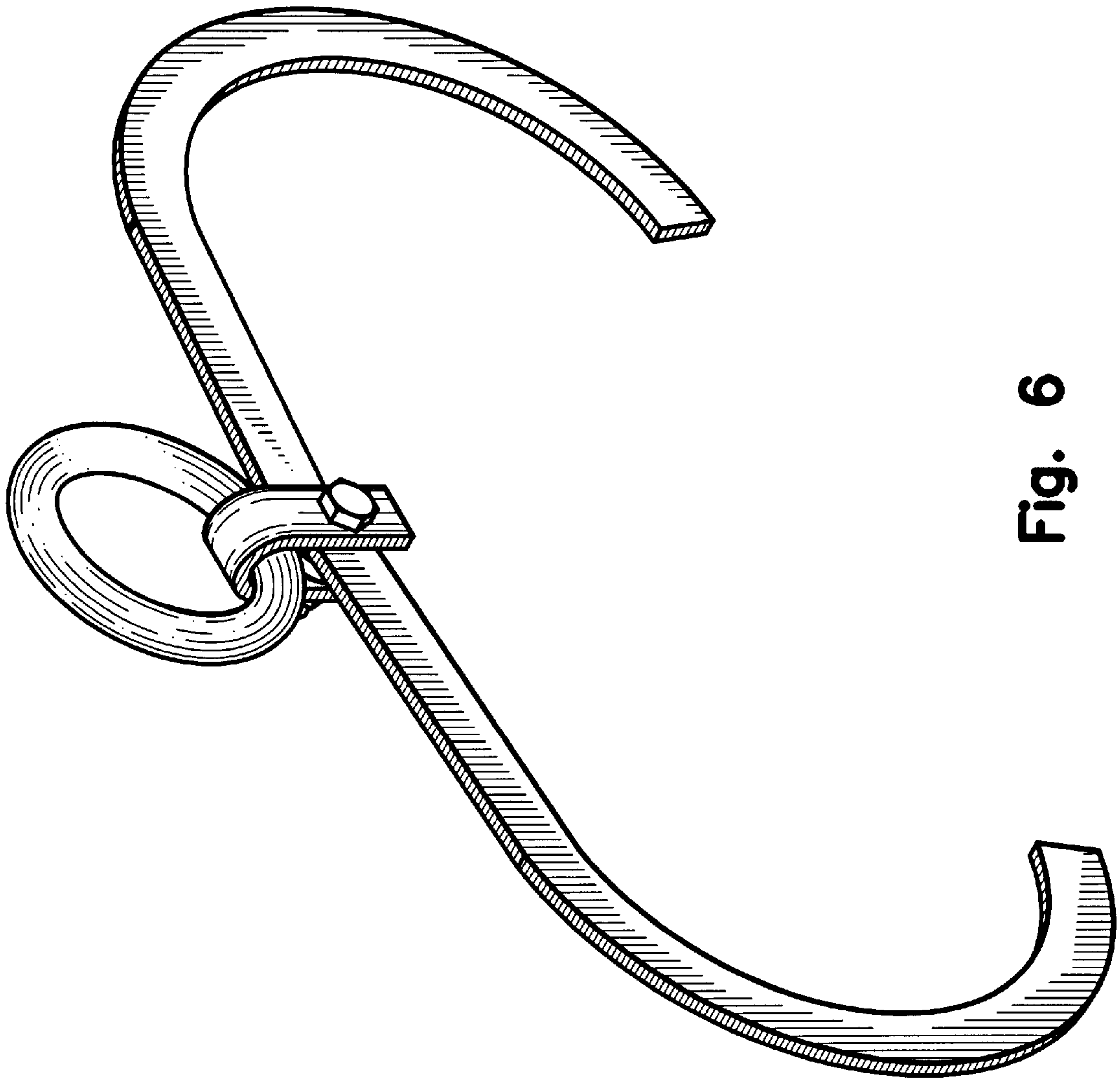

Fig. 6