



US00D425826S

United States Patent [19]

[11] Patent Number: Des. 425,826

Hellhake et al.

[45] Date of Patent: ** May 30, 2000

[54] MID-HIGH ROOF CAB OVER ENGINE TRUCK EXTERIOR SURFACE

Attorney, Agent, or Firm—Klarquist Sparkman Campbell Leigh & Winston, LLP

[75] Inventors: Ferdinand F. Hellhake, Beaverton, Oreg.; Joachim Paschke, Gechingen, Germany; Mark S. Hurayt, Aloha; Sigmund D. Runyon, Sandy, both of Oreg.

[57] CLAIM

We claim the ornamental design for a mid-high roof cab over engine truck exterior surface, as shown and described.

[73] Assignee: Freightliner Corporation, Portland, Oreg.

DESCRIPTION

[**] Term: 14 Years

FIG. 1 is a perspective view of one embodiment of the exterior surface of a truck of the present invention.

[21] Appl. No.: 29/093,605

FIG. 2 is a right side view of the truck exterior surface of FIG. 1.

[22] Filed: Sep. 15, 1998

FIG. 3 is a left side view of the truck exterior surface of FIG. 1.

[51] LOC (7) Cl. 12-08

FIG. 4 is a top view of the truck exterior surface of FIG. 1.

[52] U.S. Cl. D12/96

FIG. 5 is a bottom view of the truck exterior surface of FIG. 1.

[58] Field of Search D12/96, 97; 296/190, 296/181-183; 180/89.12, 89.14, 89.16, 89.19

FIG. 6 is a front view of the truck exterior surface of FIG. 1.

FIG. 7 is a back view of the truck exterior surface of FIG. 1.

[56] References Cited

FIG. 8 is a front perspective view of a second embodiment of a truck exterior surface of the present invention without the optional rear sleeper compartment door panel and door window.

U.S. PATENT DOCUMENTS

D. 302,257	7/1989	Bretschweidt et al.	D12/96
D. 344,472	2/1994	Savio	D12/98
D. 367,443	2/1996	Fauo et al.	D12/96
D. 394,026	5/1998	Hellhake et al.	D12/96
D. 399,791	10/1998	Hellhake et al.	D12/96
D. 399,792	10/1998	Hellhake et al.	D12/96
D. 406,552	3/1999	Hellhake et al.	D12/93
D. 406,553	3/1999	Hellhake et al.	D12/96
D. 408,331	4/1999	Fauo et al.	D12/96
4,143,732	3/1979	Schnule et al.	180/686

FIG. 9 is a right side view of the truck exterior surface of FIG. 8.

FIG. 10 is the left side view of the truck exterior surface of FIG. 8, it being understood that the bottom, back, front and top views of the truck exterior surface of FIG. 8 are identical to those of the embodiment of FIG. 1; and,

OTHER PUBLICATIONS

Freightliner Corporation Brochure: "Freightliner Cab Over Engine", Copyright 1988.

FIG. 11 is a front view of a third embodiment of a truck exterior surface of the present invention showing the truck exterior surface with a optional two-piece windshield and optional passenger door window, it being understood that the other features of the truck exterior surface of the FIG. 11 embodiment are alternatively identical to those of the embodiment of FIG. 1 and the embodiment of FIG. 8.

Freightliner Corporation Brochure: "The New Freightliner C.O.E.", Copyright 1993.

The truck portions shown in broken lines are for illustrative purposes only and form no part of the claimed design.

Freightliner Corporation Brochure: "You Expect More From Freightliner. And You Should" (depicting prior art vehicle).

Primary Examiner—Melody N. Brown

1 Claim, 11 Drawing Sheets

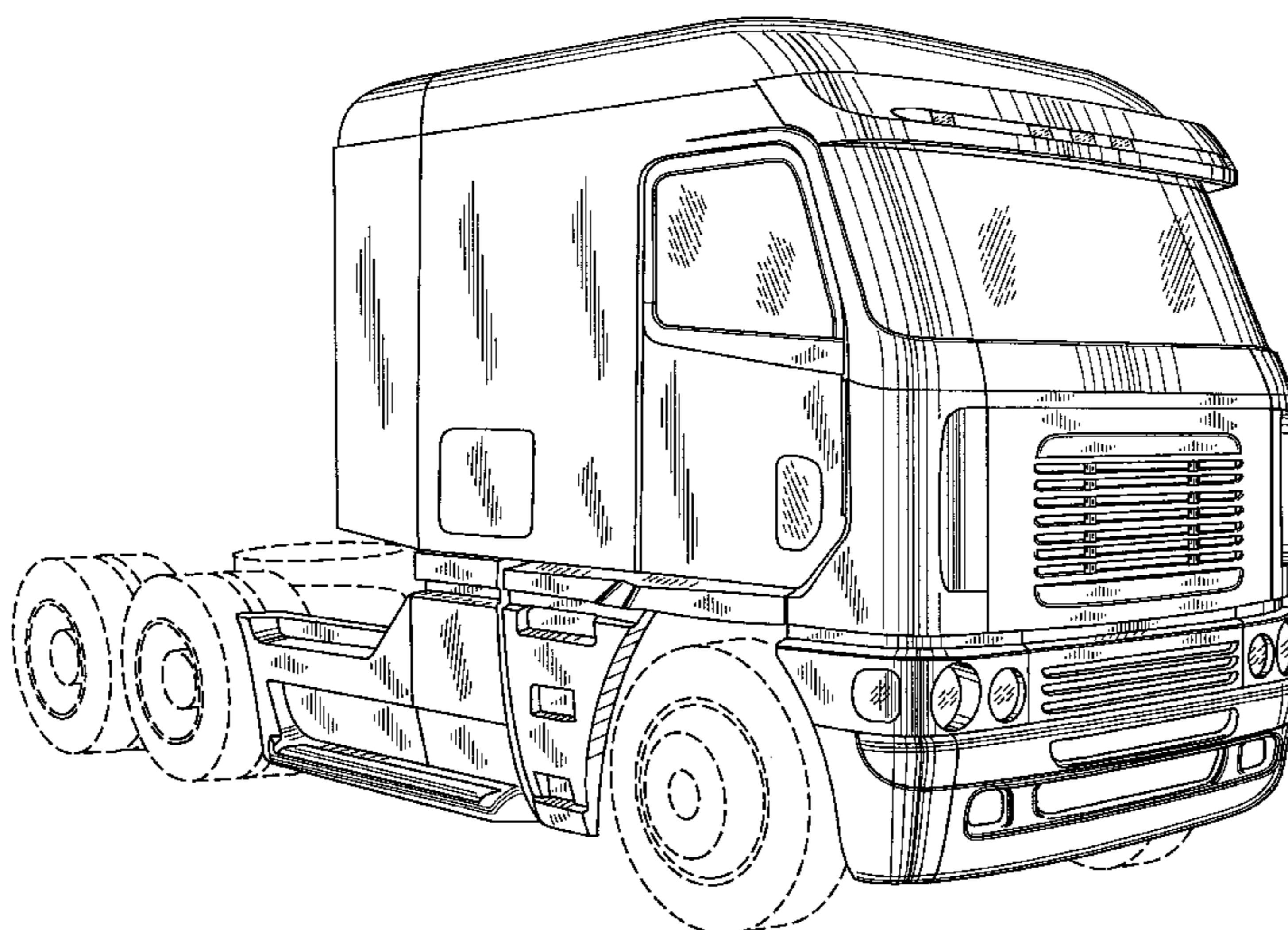

FIG. 1

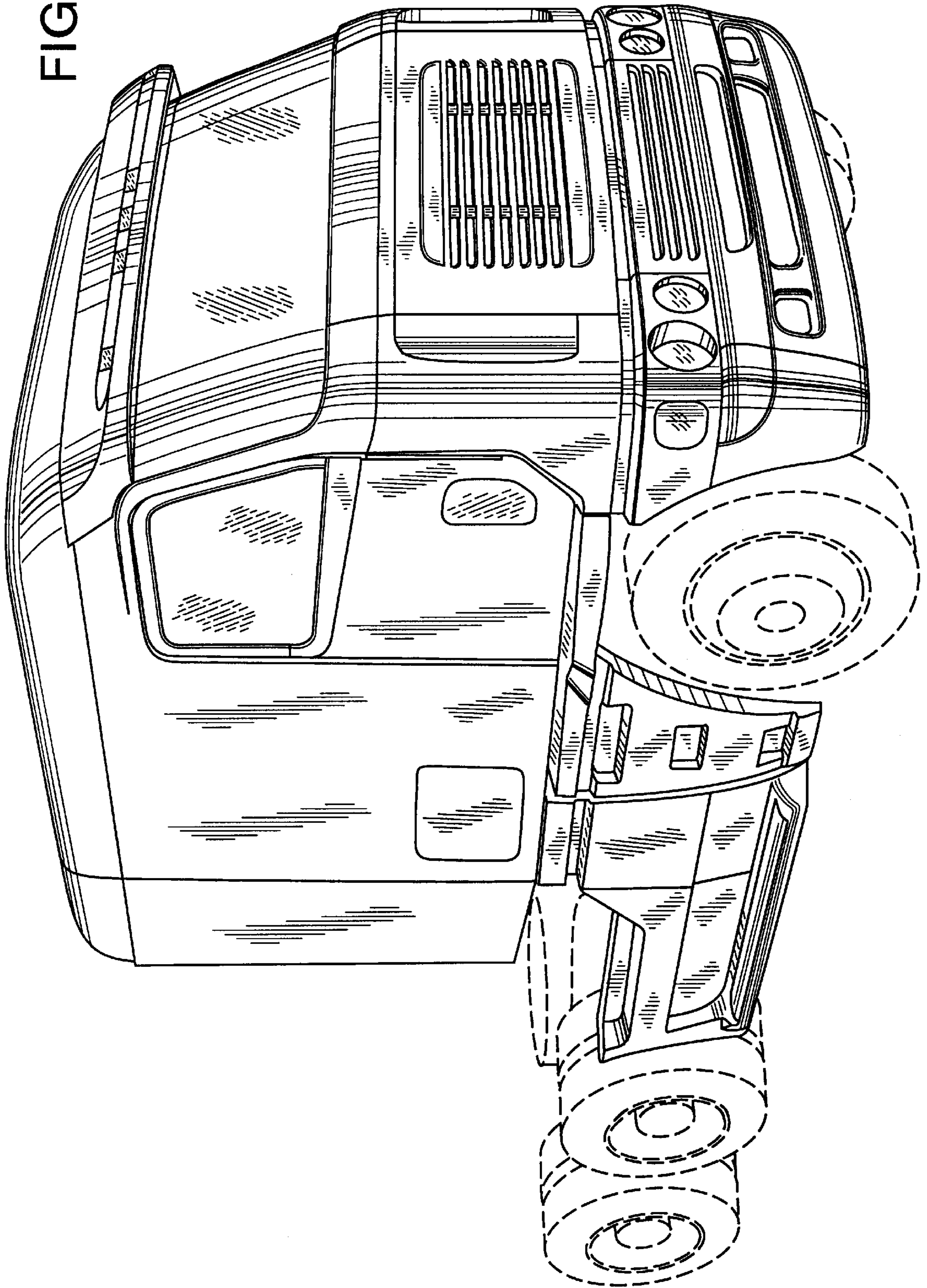

FIG. 2

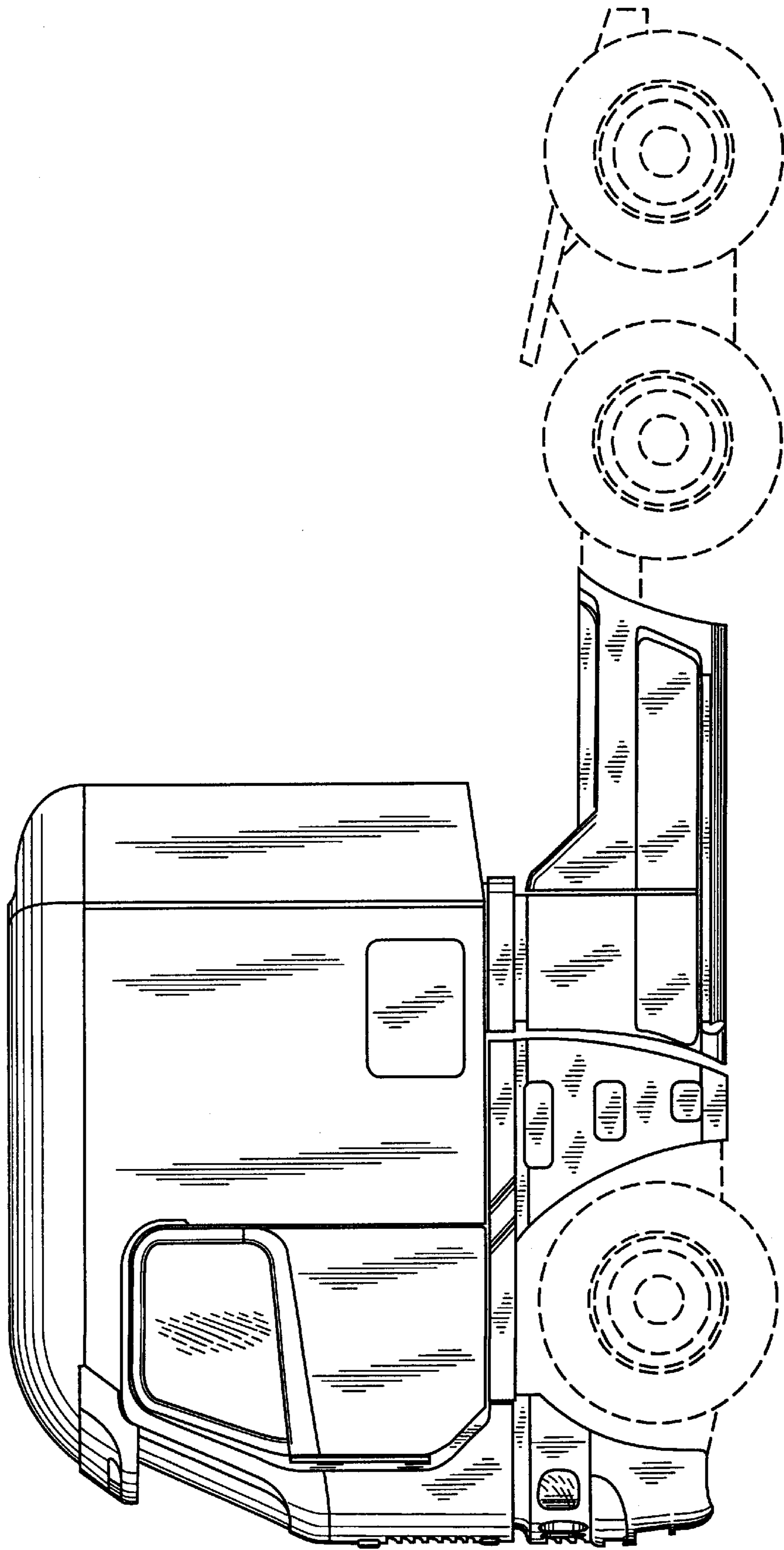

FIG. 3

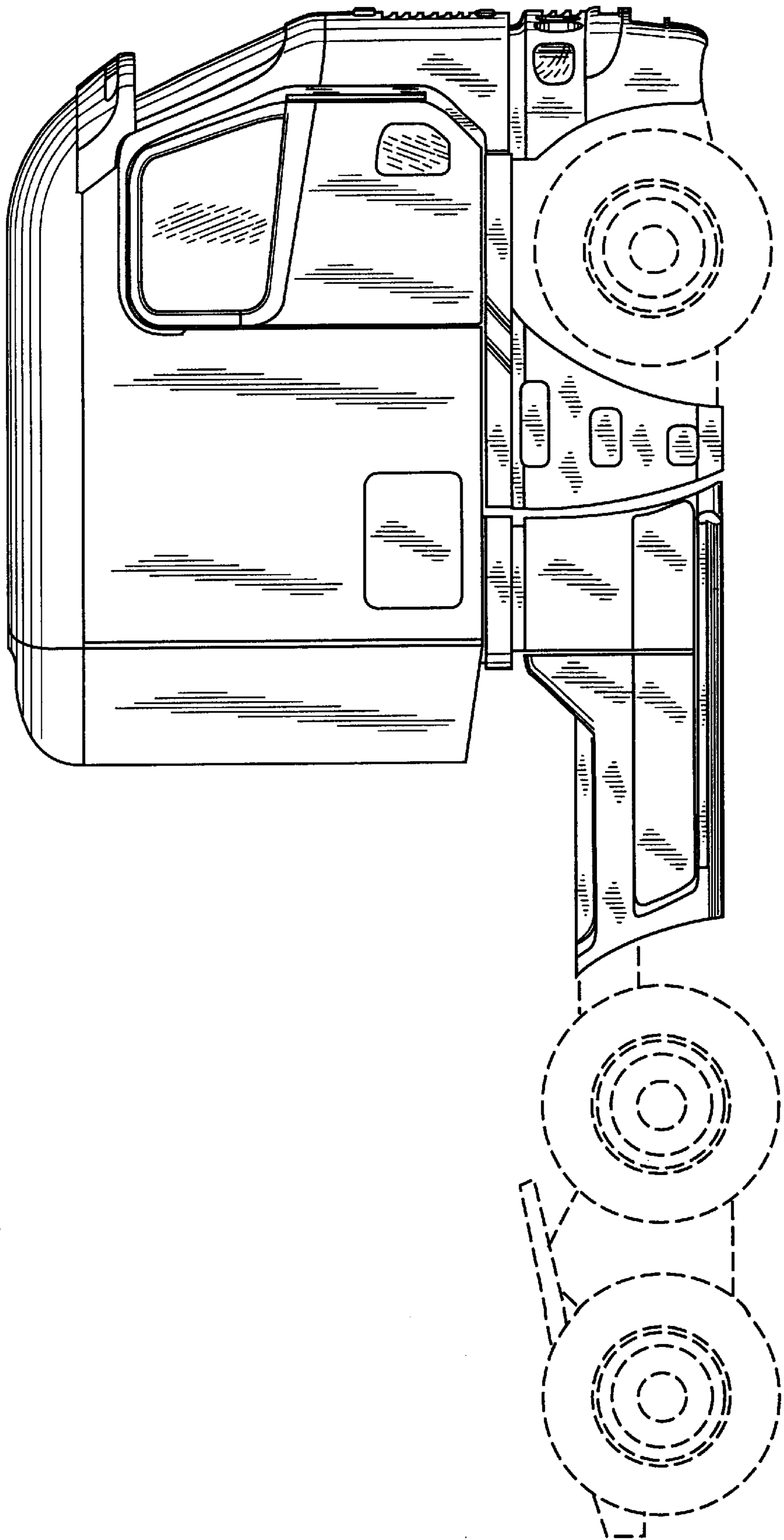
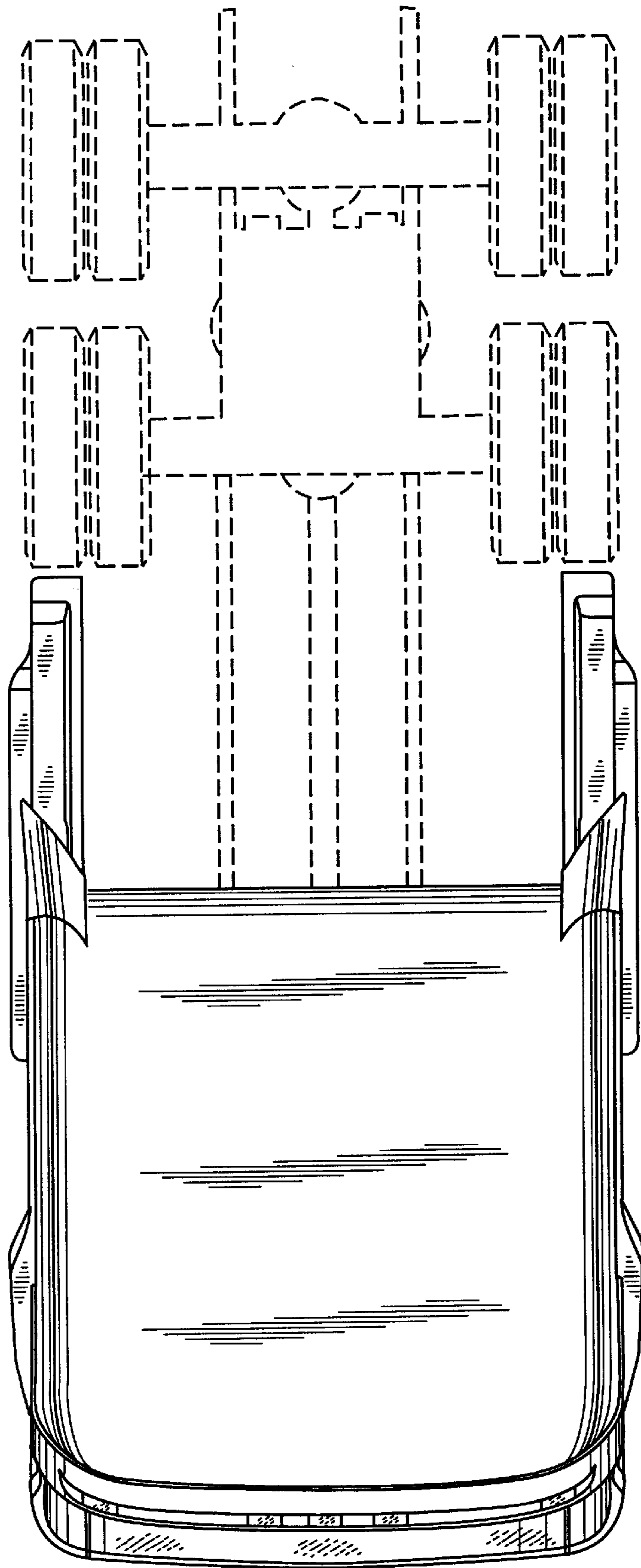

FIG. 4



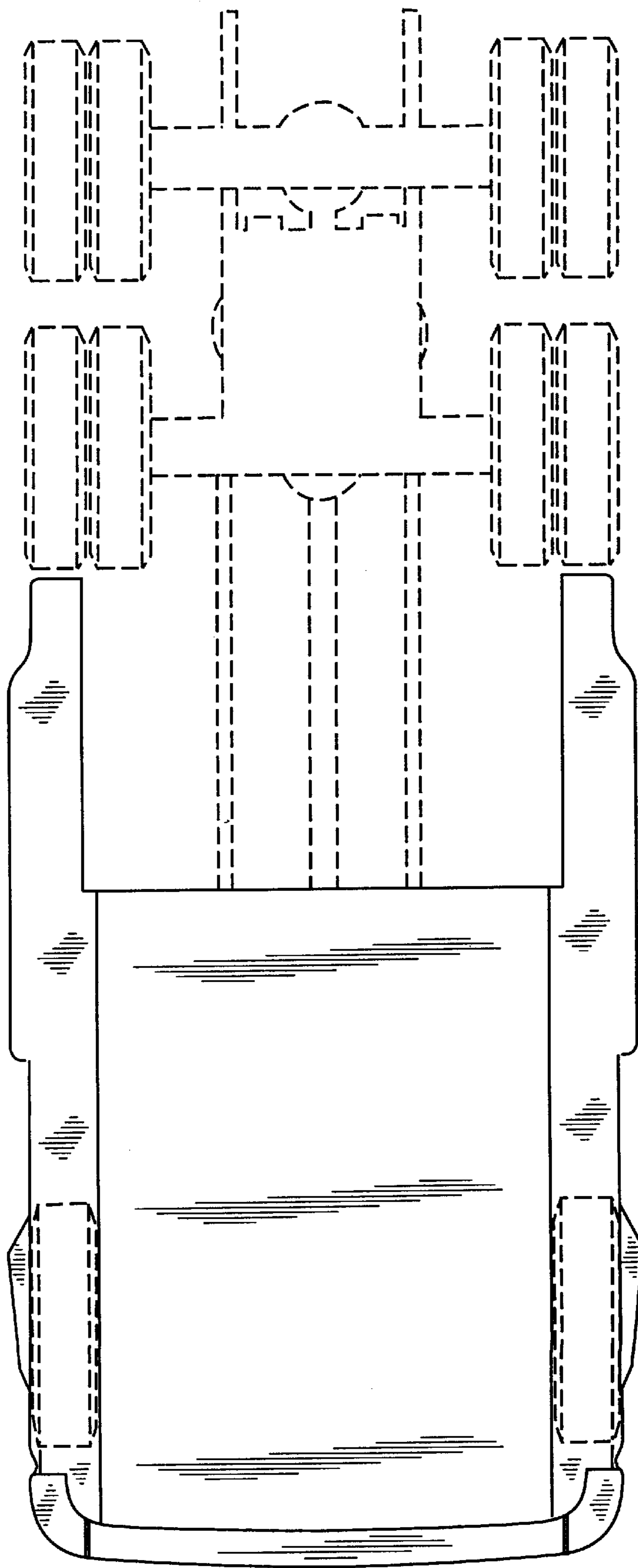

FIG. 5

FIG. 6

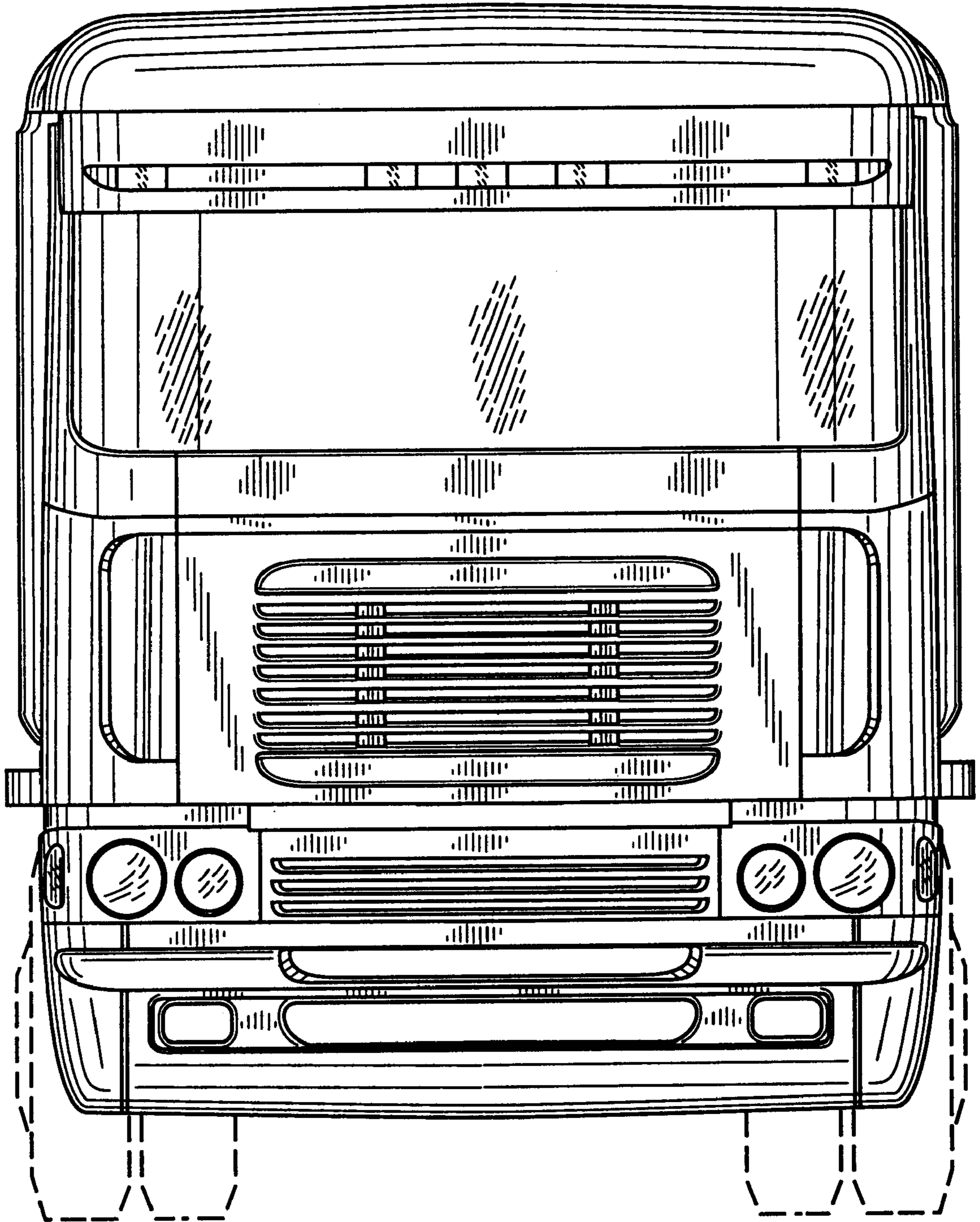
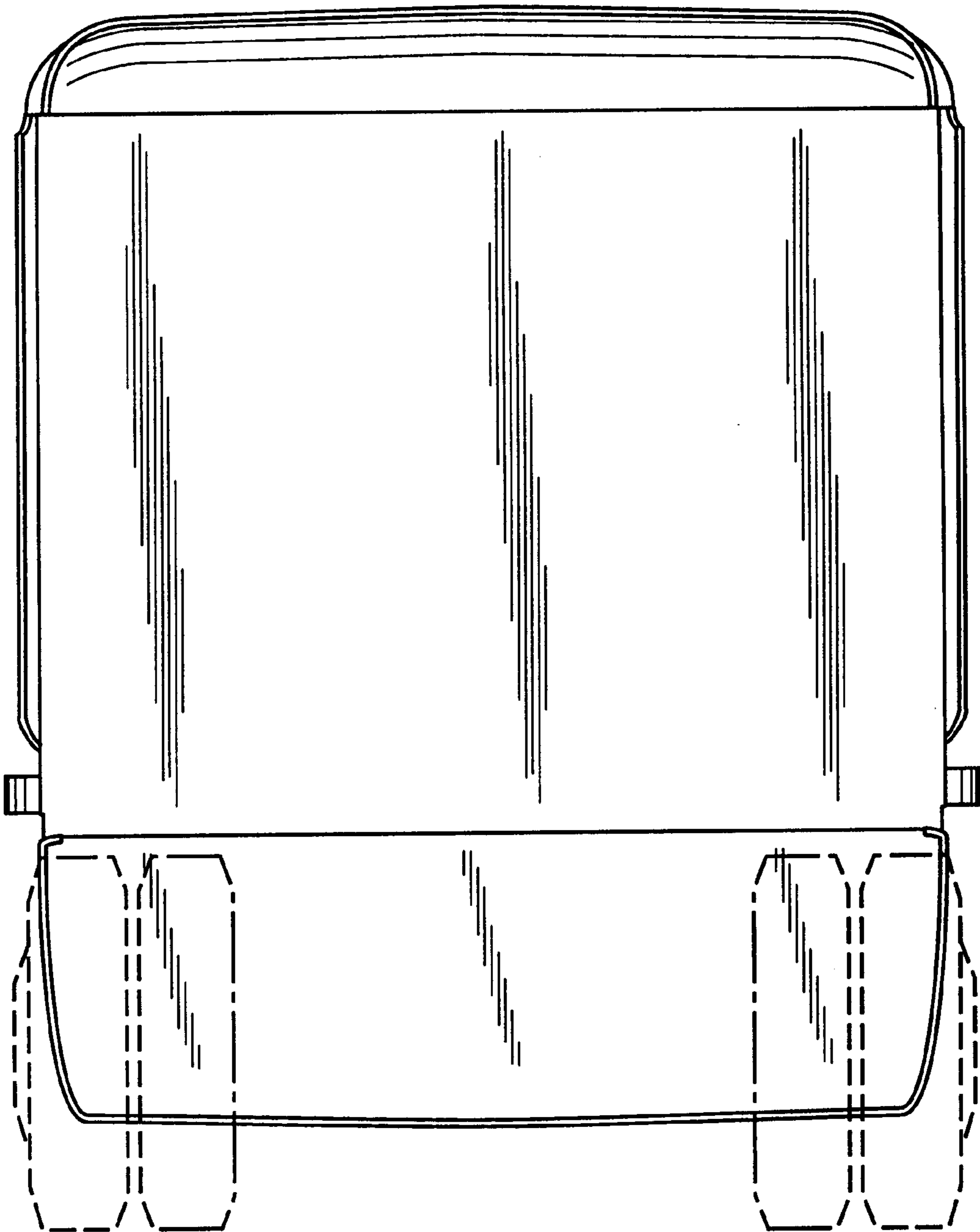

FIG. 7



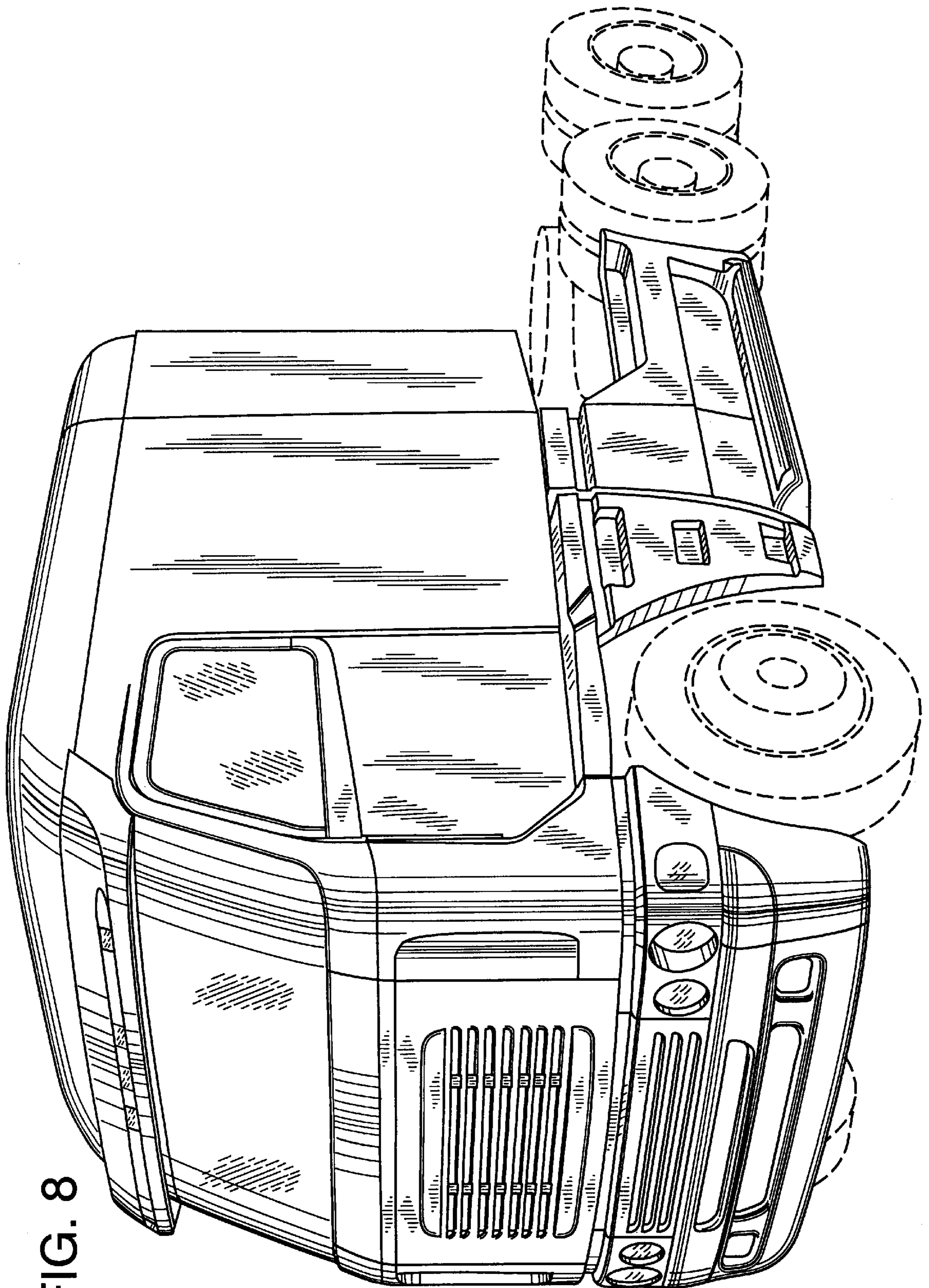

FIG. 8

FIG. 9

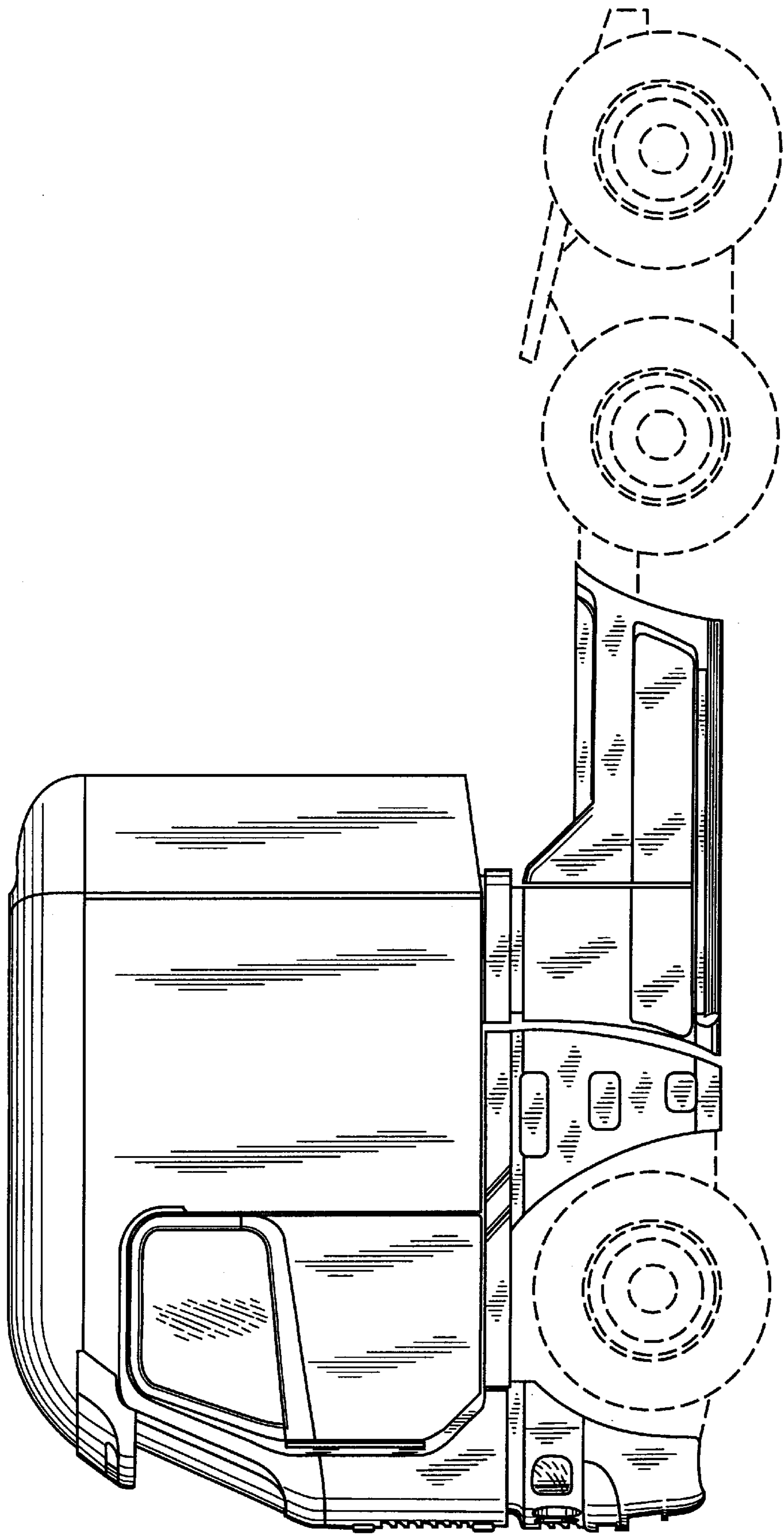

FIG. 10

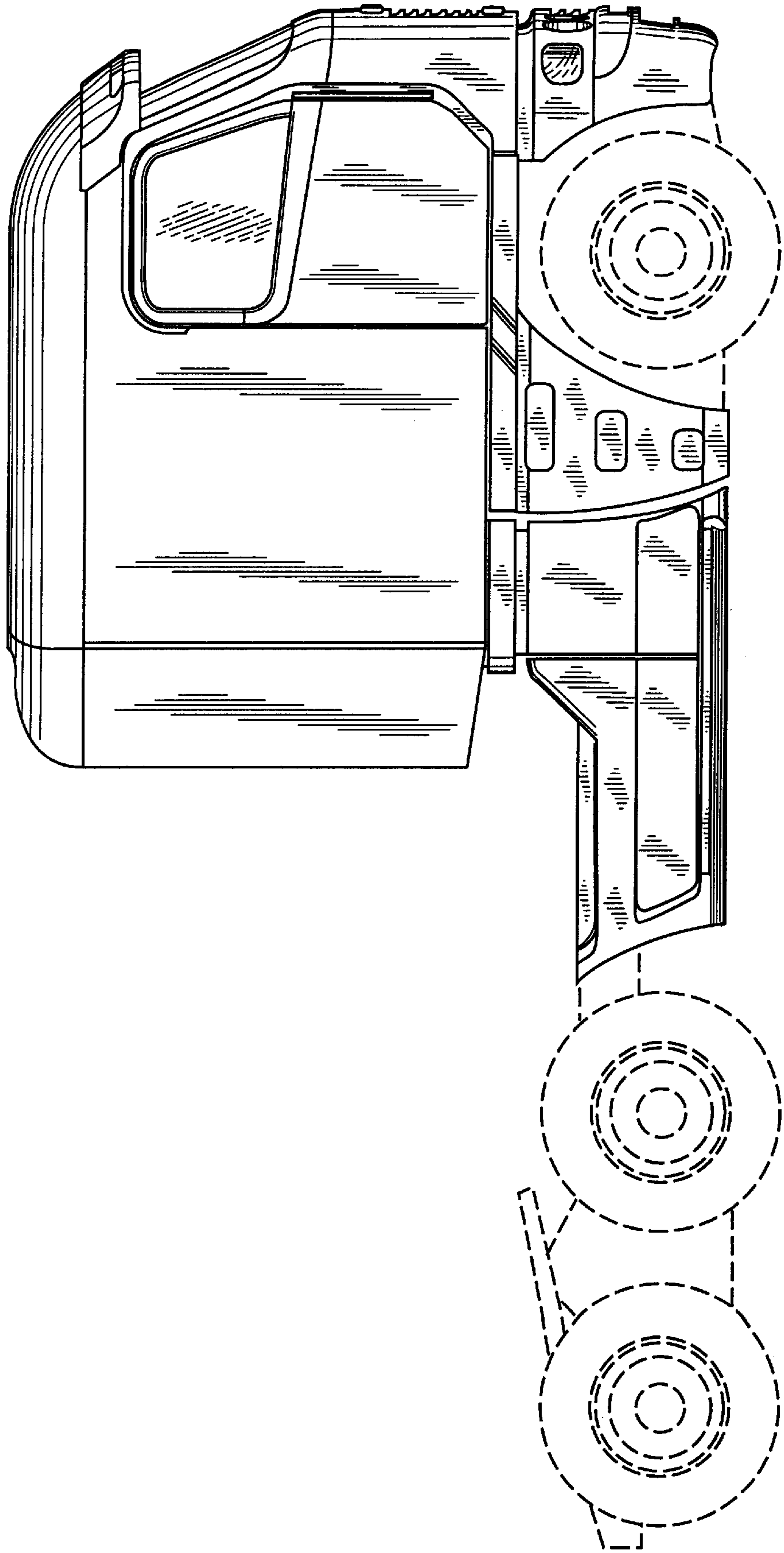

FIG. 11

