



US00D425824S

# United States Patent [19]

Hsu et al.

[11] **Patent Number: Des. 425,824**

[45] **Date of Patent: \*\* May 30, 2000**

[54] **AUTOMOBILE**

[75] Inventors: **Ricky Ju Kuei Hsu**, Gardena; **Michael Patrick May**, Redondo Beach, both of Calif.

[73] Assignee: **Honda Giken Kogyo Kabushiki**, Tokyo, Japan

[\*\*] Term: **14 Years**

[21] Appl. No.: **29/090,578**

[22] Filed: **Jul. 10, 1998**

[51] **LOC (7) Cl.** ..... **12-08**

[52] **U.S. Cl.** ..... **D12/92**

[58] **Field of Search** ..... D12/90-92; 296/185

[56] **References Cited**

**U.S. PATENT DOCUMENTS**

D. 351,573	10/1994	Kong et al.	.....	D12/92
D. 372,687	8/1996	Boyer	.....	D12/92
D. 373,334	9/1996	Honda et al.	.....	D12/92
D. 379,946	6/1997	Ganable et al.	.....	D12/92
D. 379,947	6/1997	Ichinose et al.	.....	D12/92
D. 391,523	3/1998	Sacco et al.	.....	D12/92
D. 402,232	12/1998	Hayachi et al.	.....	D12/92

*Primary Examiner*—Melody N. Brown  
*Attorney, Agent, or Firm*—Birch, Stewart, Kolasch & Birch, LLP

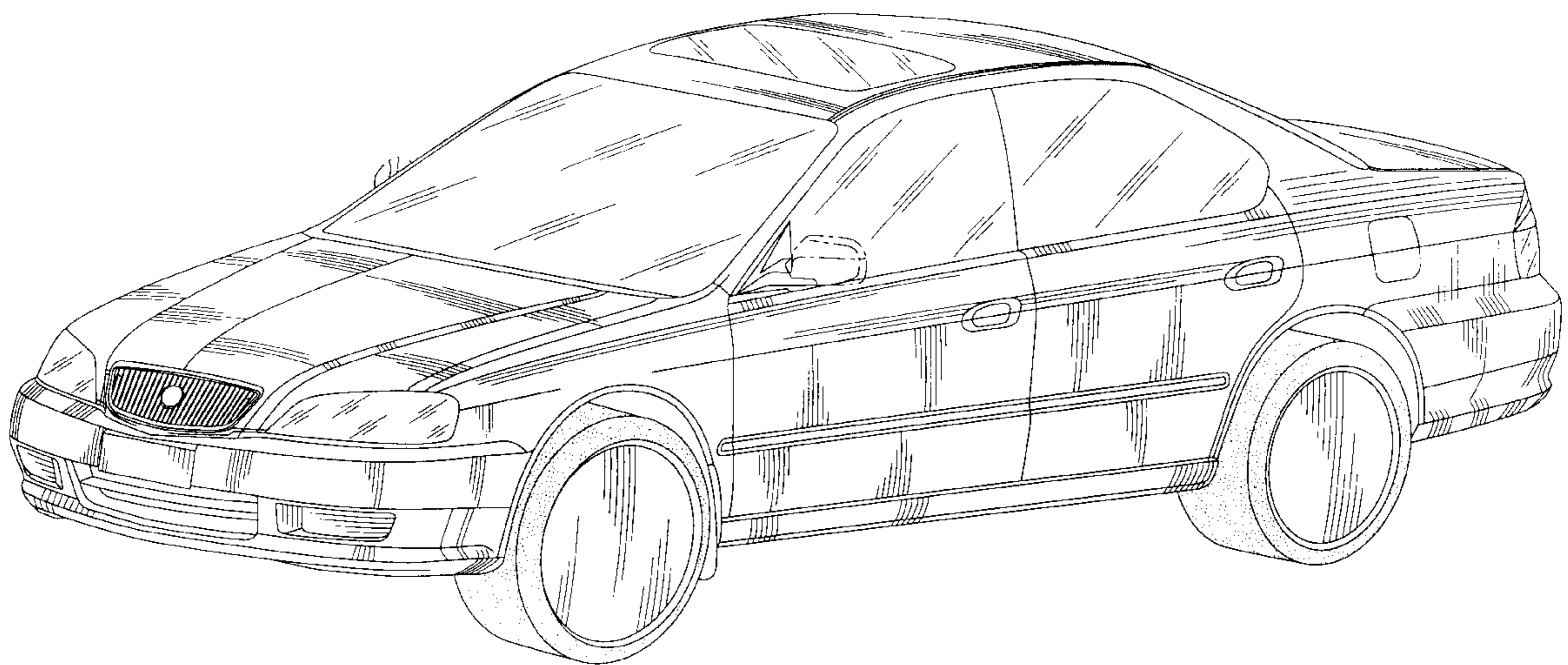
[57] **CLAIM**

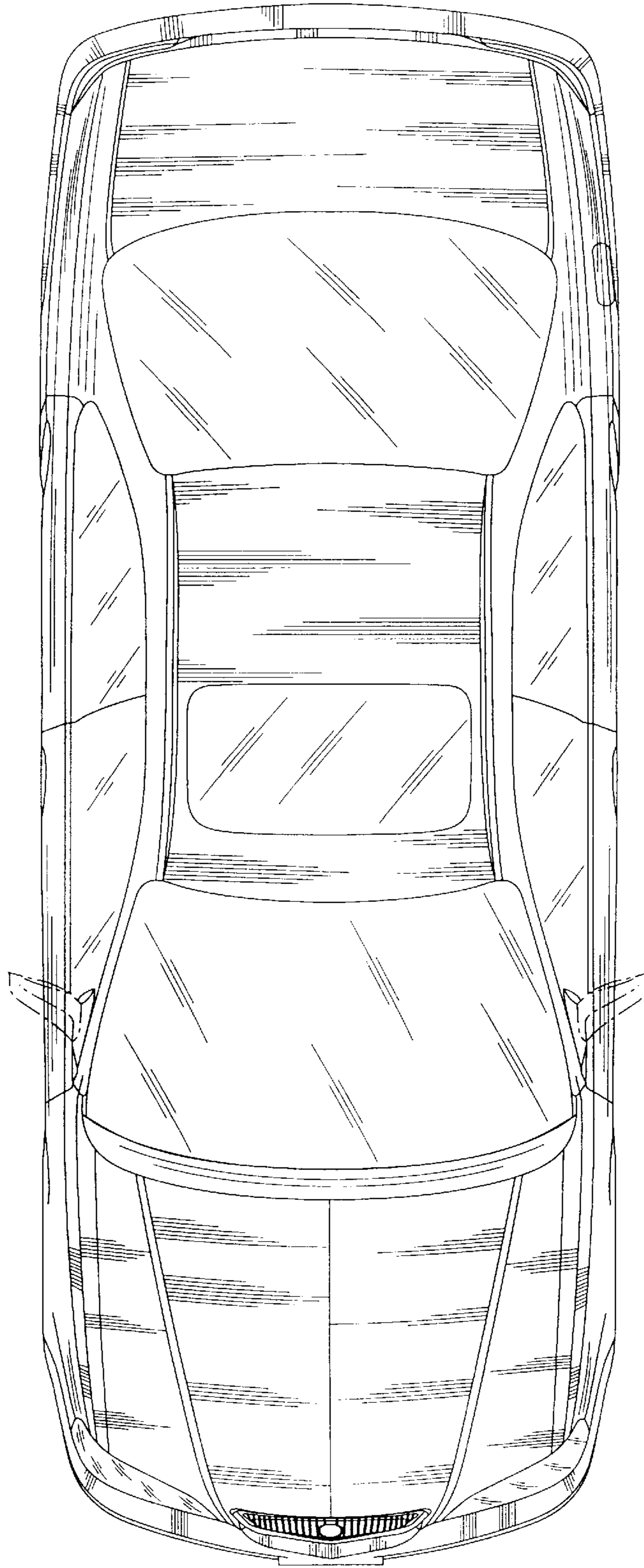
We claim the ornamental design of an automobile, as shown and described.

**DESCRIPTION**

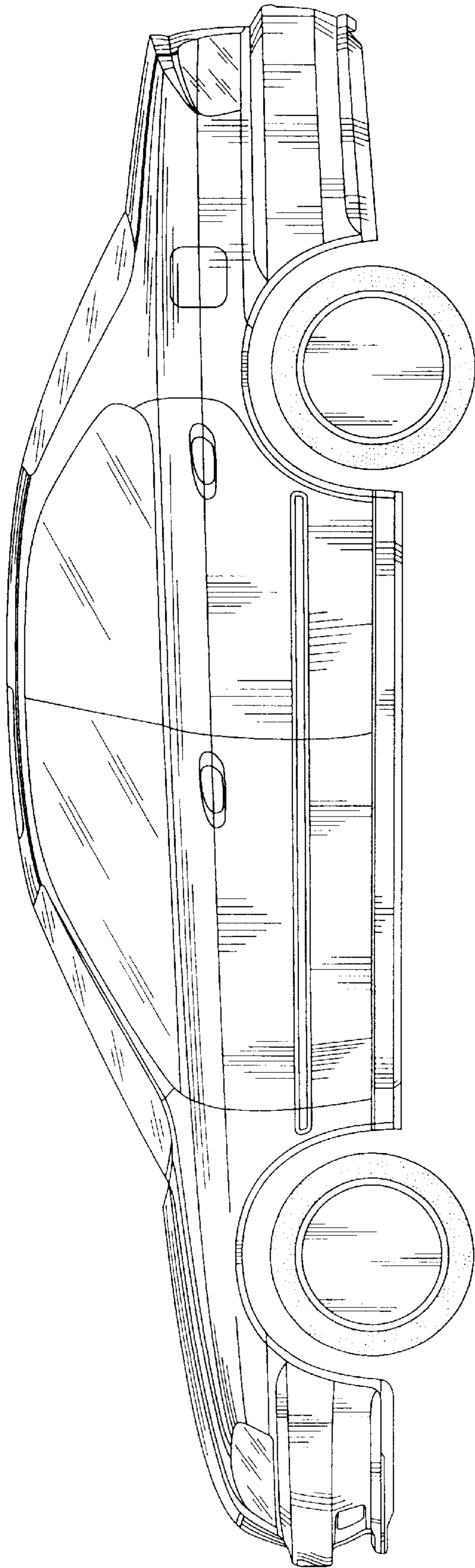
FIG. 1 a top plan view of the automobile showing our new design;  
FIG. 2 is a right side, elevational view of the automobile of FIG. 1, the left side being a mirror image thereof;  
FIG. 3 is a rear elevational view of the automobile of FIG. 1;  
FIG. 4 is a front elevational view of the automobile of FIG. 1;  
FIG. 5 is a front, right perspective view of the automobile; FIG. 6 is a rear, left perspective view of the automobile; and, FIG. 7 is a front view of a second embodiment of the automobile showing a modified grill, the remaining views of FIG. 7 corresponding to those of the first embodiment.  
The broken line showings are for environmental purposes only and form no part of the claimed design.

**1 Claim, 6 Drawing Sheets**

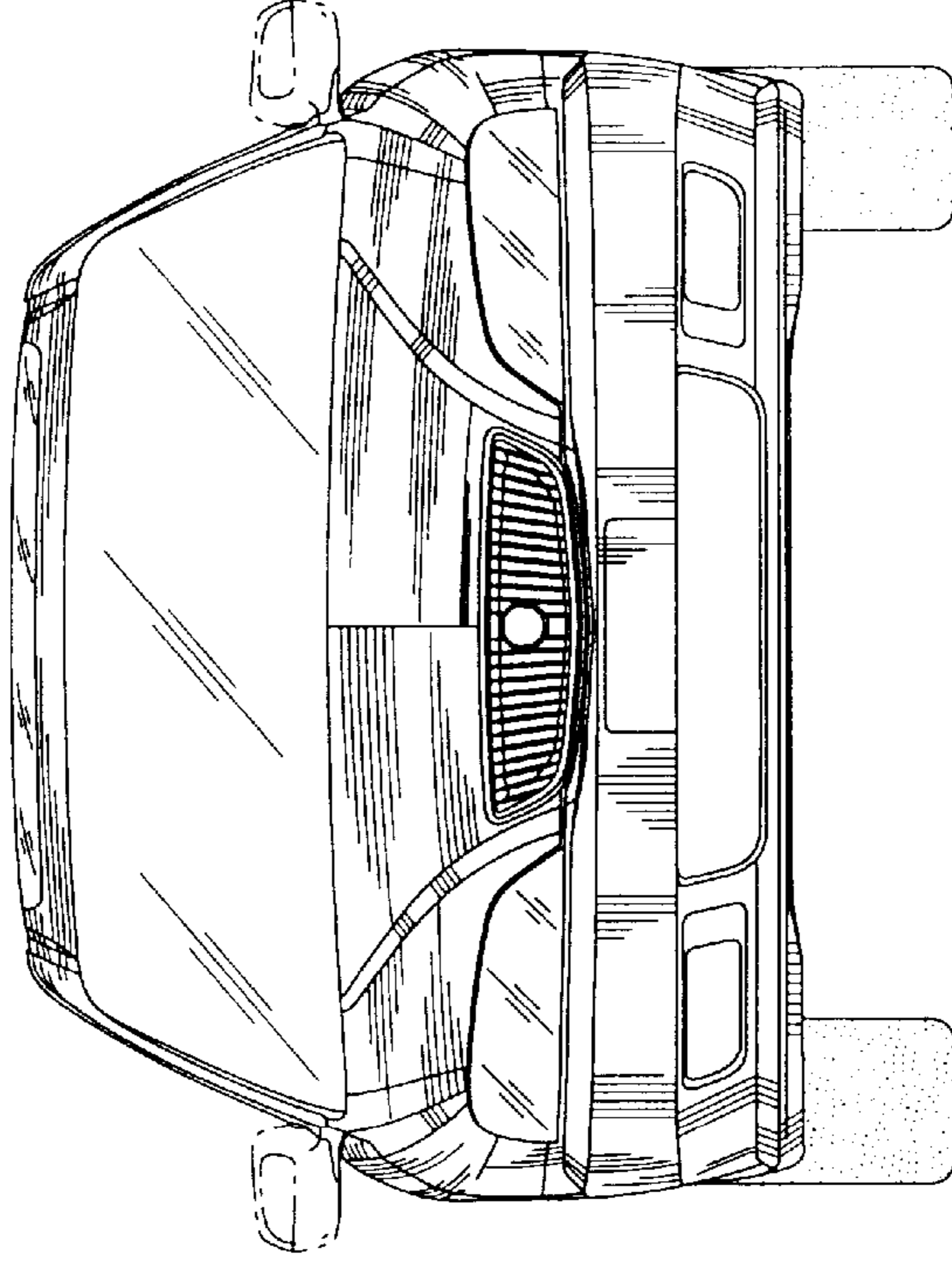




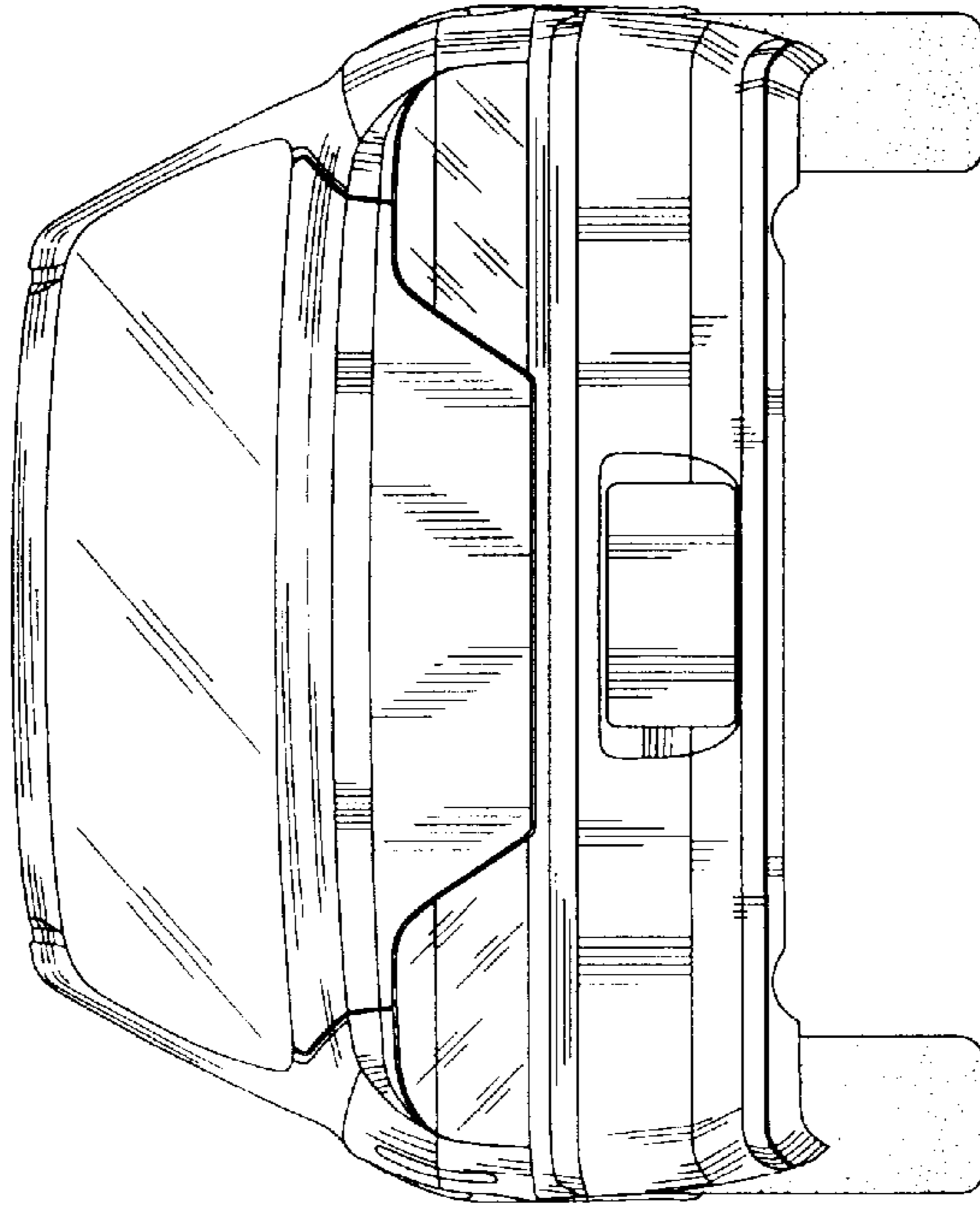
**FIG. 1**



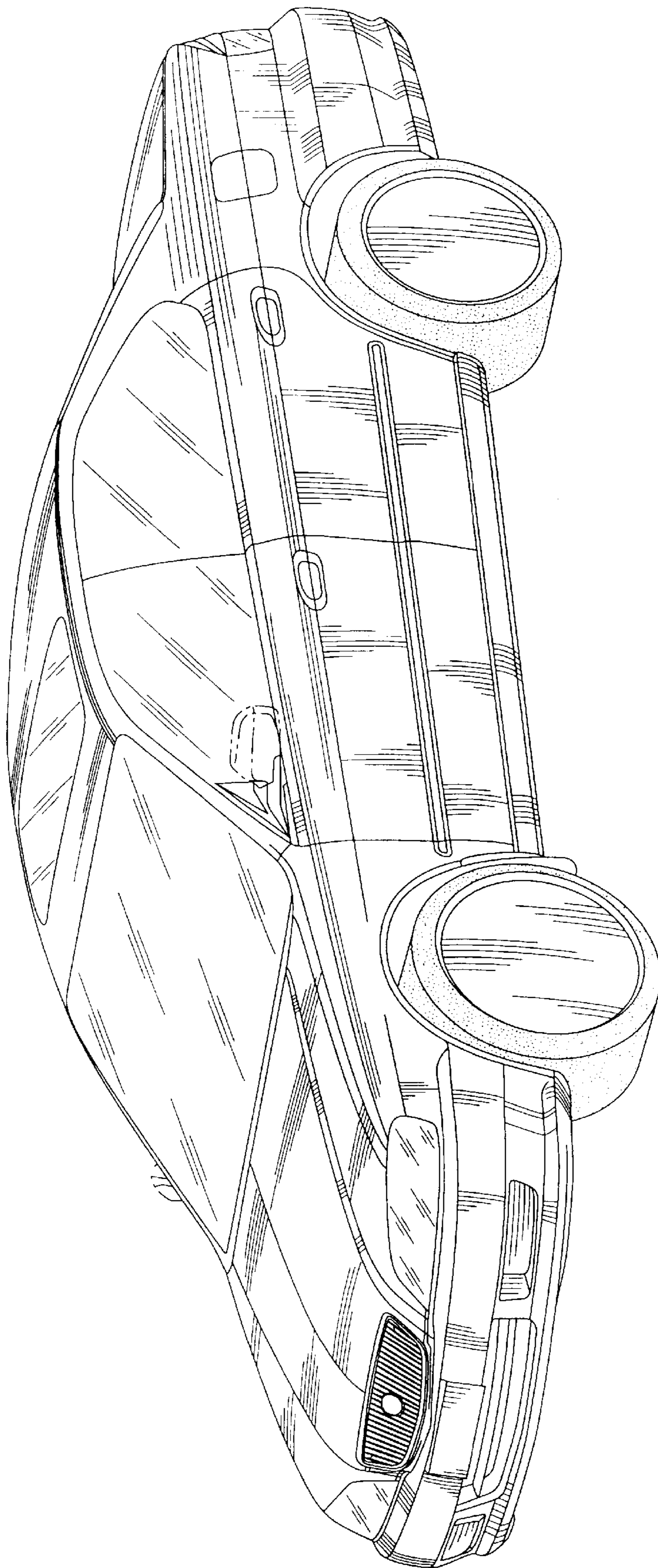
**FIG. 2**



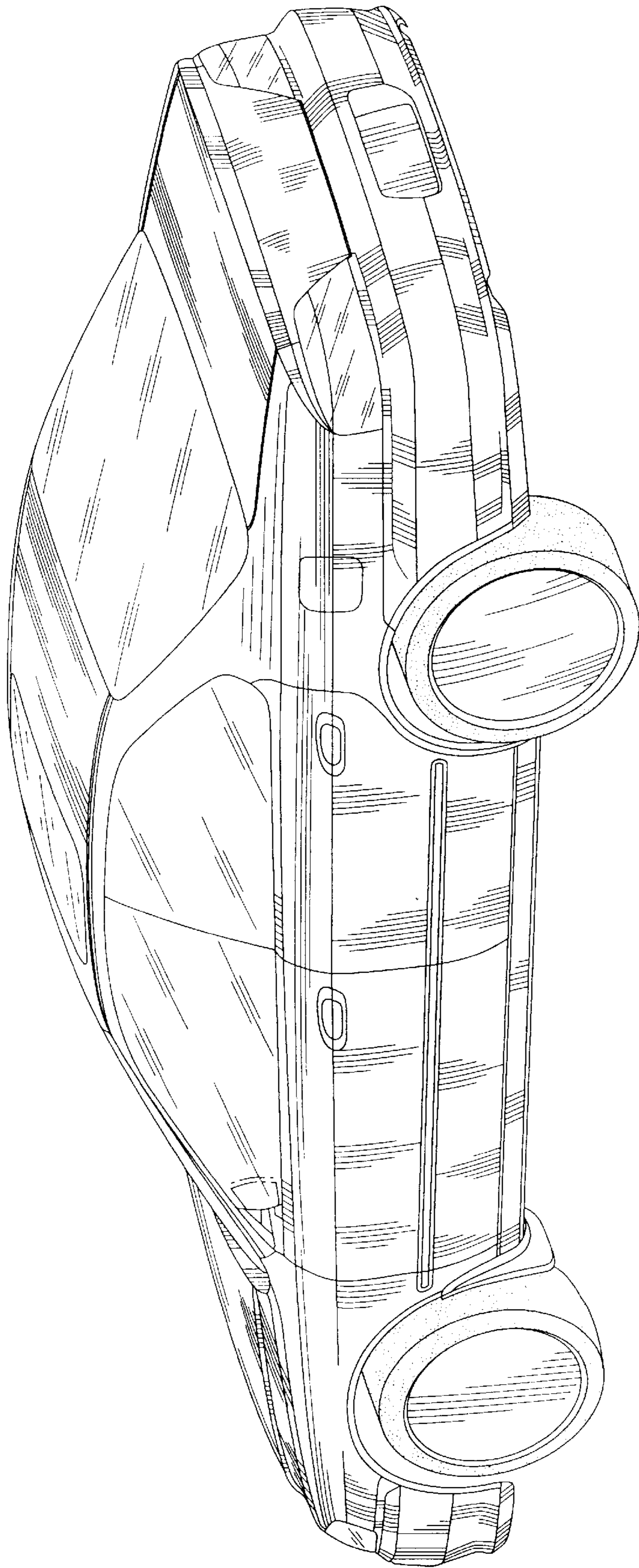
**FIG. 4**



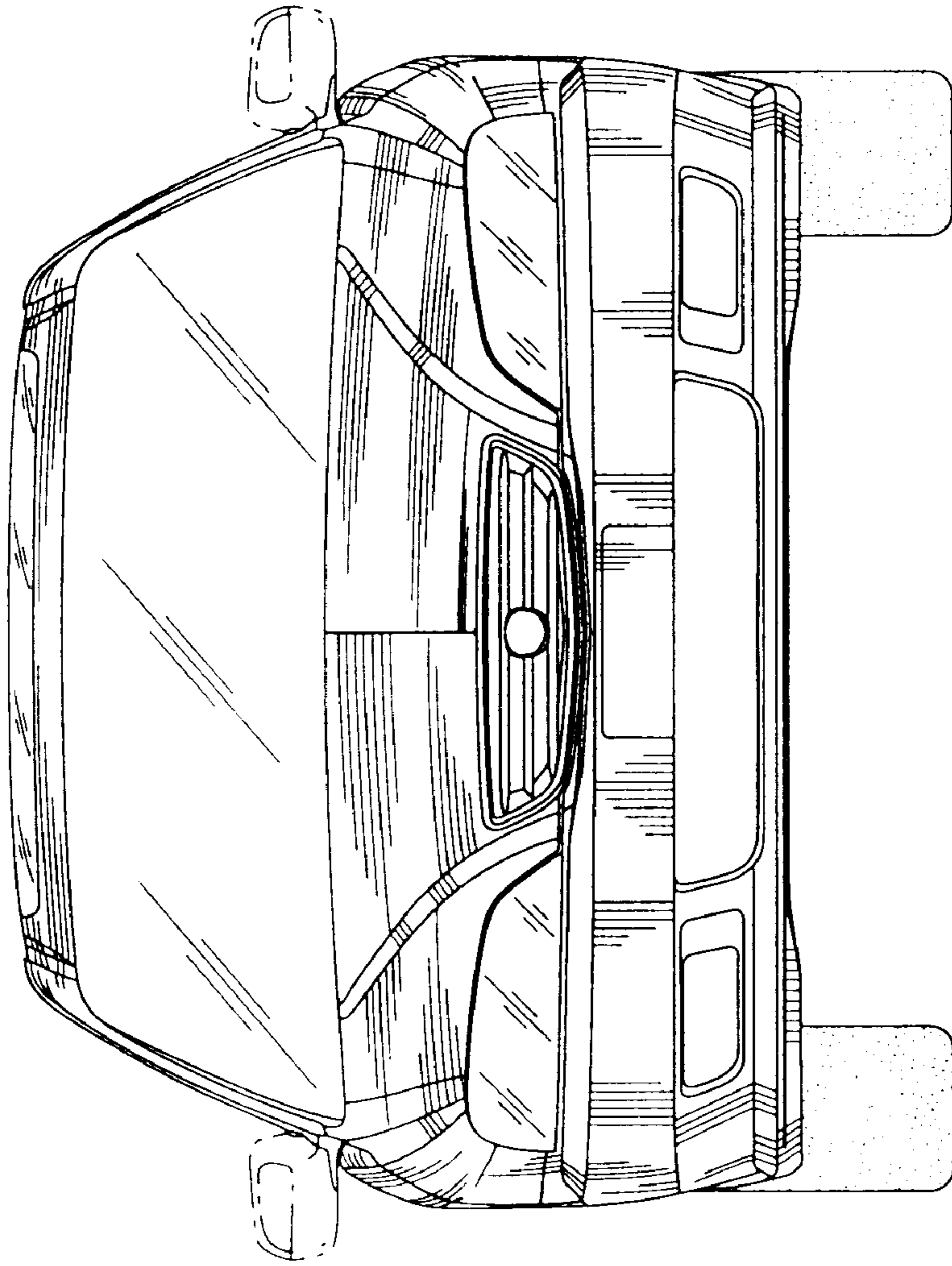
**FIG. 3**



**FIG. 5**



**FIG. 6**



**FIG. 7**