



US00D425449S

United States Patent [19]

Sims et al.

[11] Patent Number: Des. 425,449

[45] Date of Patent: ** May 23, 2000

[54] AUTOMOBILE BODY

[75] Inventors: Daniel Jerome Sims, Lake Forest;
Michael Alan Desmond, Long Beach,
both of Calif.

[73] Assignee: Mitsubishi Jidosha Kogyo Kabushiki
Kaisha, Tokyo, Japan

[**] Term: 14 Years

[21] Appl. No.: 29/098,667

[22] Filed: Jan. 4, 1999

[51] LOC (7) Cl. 12-08

[52] U.S. Cl. D12/92

[58] Field of Search D12/90-92; 296/185

[56] References Cited

U.S. PATENT DOCUMENTS

D. 392,596	3/1998	Jüingst	D12/92
D. 405,390	2/1999	Castiglione et al.	D12/92
D. 406,548	3/1999	Ramaciotti	D12/92

OTHER PUBLICATIONS

Jordan, Michael; Automobile Magazine, "Looking Into the Future"; Apr. 1988, pp. 70-72.

Primary Examiner—Melody N. Brown

[57] CLAIM

The ornamental design for an automobile body, as shown and described.

DESCRIPTION

FIG. 1 is a front perspective view of an automobile body showing our new design;

FIG. 2 is a rear perspective view thereof;

FIG. 3 is a front elevation view thereof;

FIG. 4 is a rear elevation view thereof;

FIG. 5 is a right side elevation view thereof;

FIG. 6 is a top plan view thereof;

FIG. 7 is a front perspective view of a second embodiment of an automobile body showing our new design;

FIG. 8 is a rear perspective view of the automobile body of FIG. 7;

FIG. 9 is a front elevation view of the automobile body of FIG. 7;

FIG. 10 is a rear elevation view of the automobile body of FIG. 7;

FIG. 11 is a right side elevation view of the automobile body of FIG. 7;

FIG. 12 is a top plan view of the automobile body of the automobile body of FIG. 7; and,

FIG. 13 is a right side elevation view of the automobile body of FIG. 7 is with a roof up.

A left side elevation view of the automobile body of FIG. 1 and a left side elevation view of the automobile body of FIG. 7 have been omitted since they are symmetrical to FIGS. 5 and 11, respectively.

The broken lines showing of environmental structure in FIGS. 1, 2, 3, 4, 5, 7, 8, 9, 10, 11, and 12 of the drawing are for illustrative purposes only and form no part of the claimed design.

1 Claim, 11 Drawing Sheets

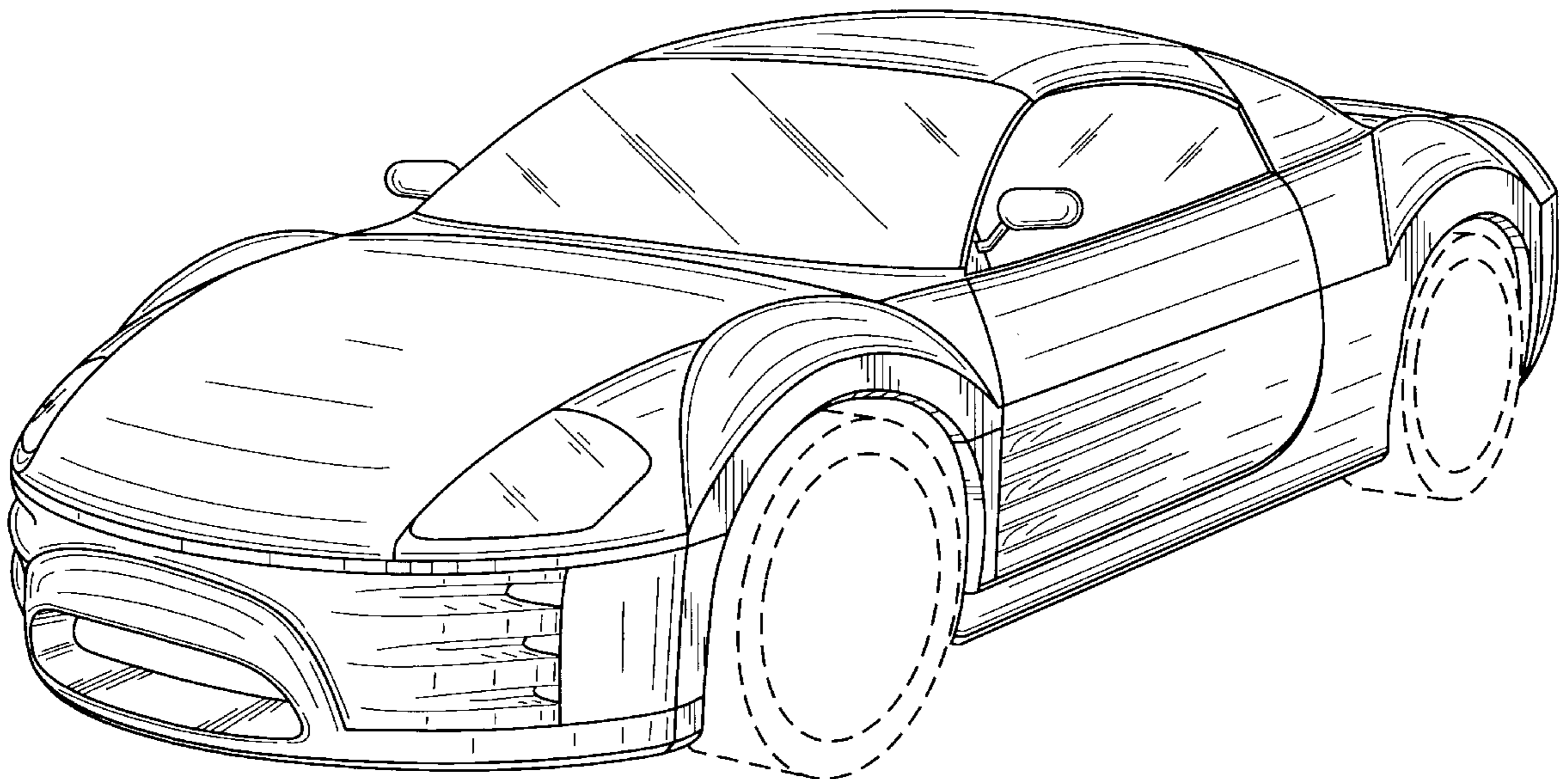

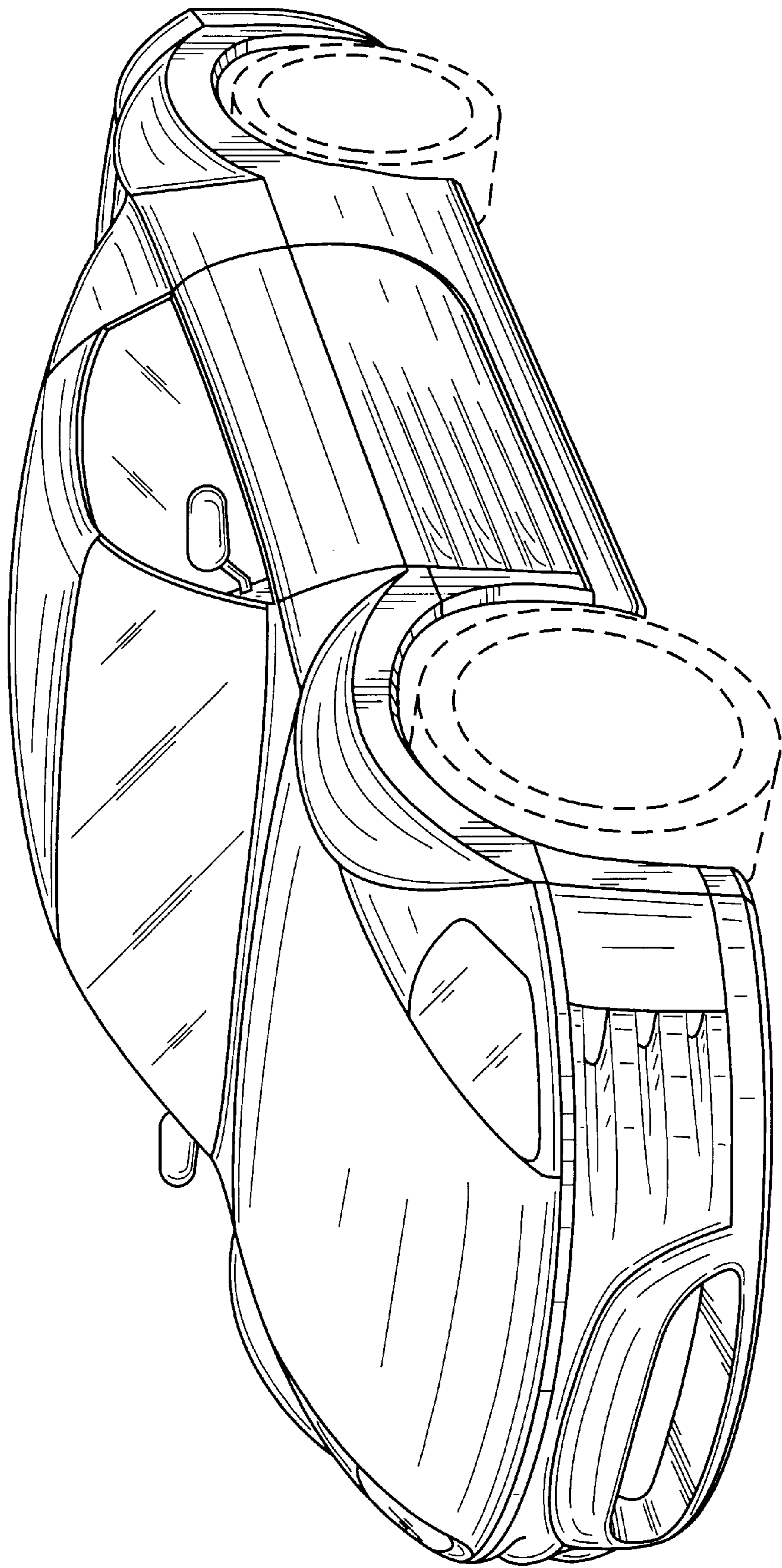

FIG. 1

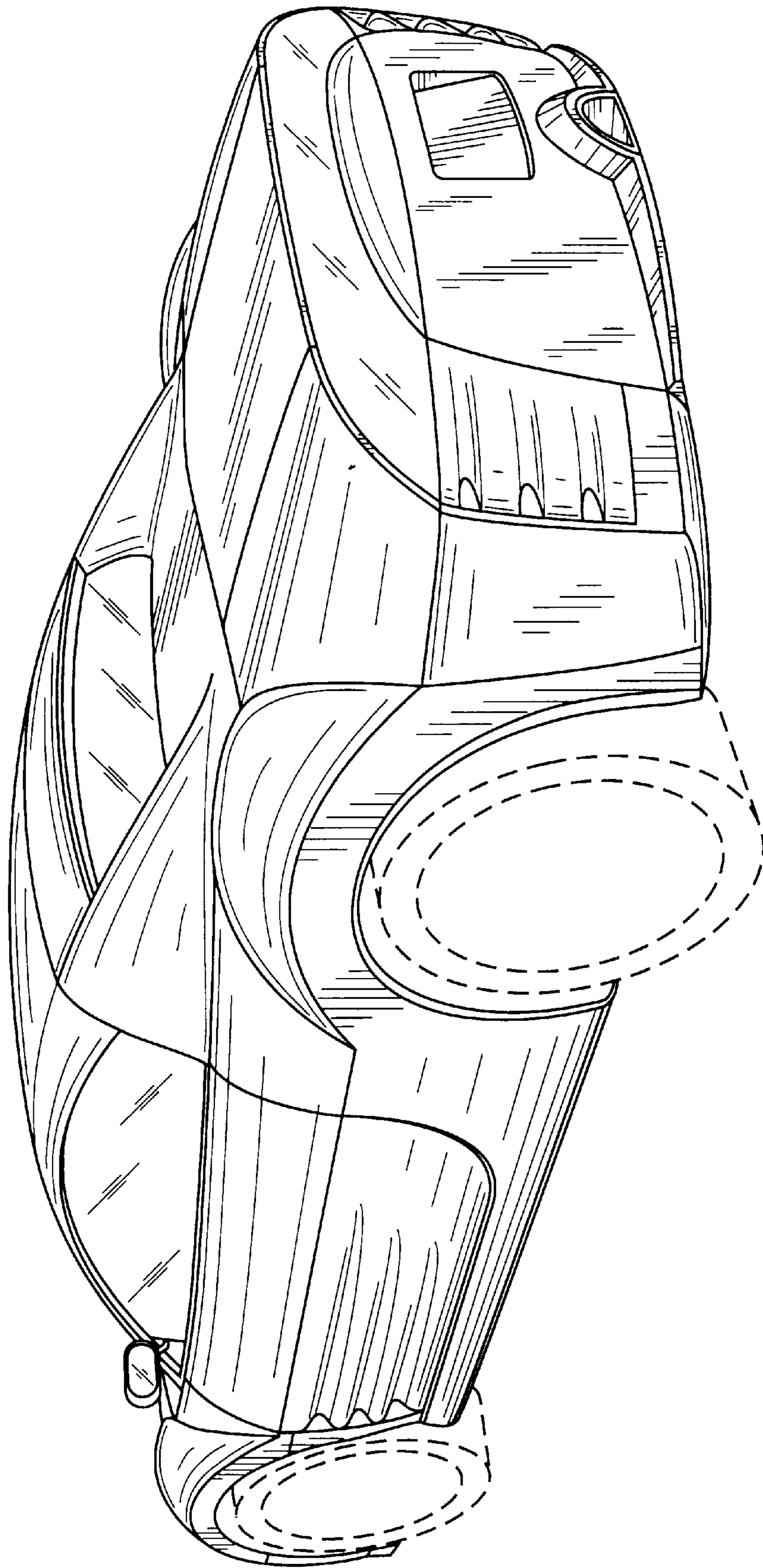

FIG. 2

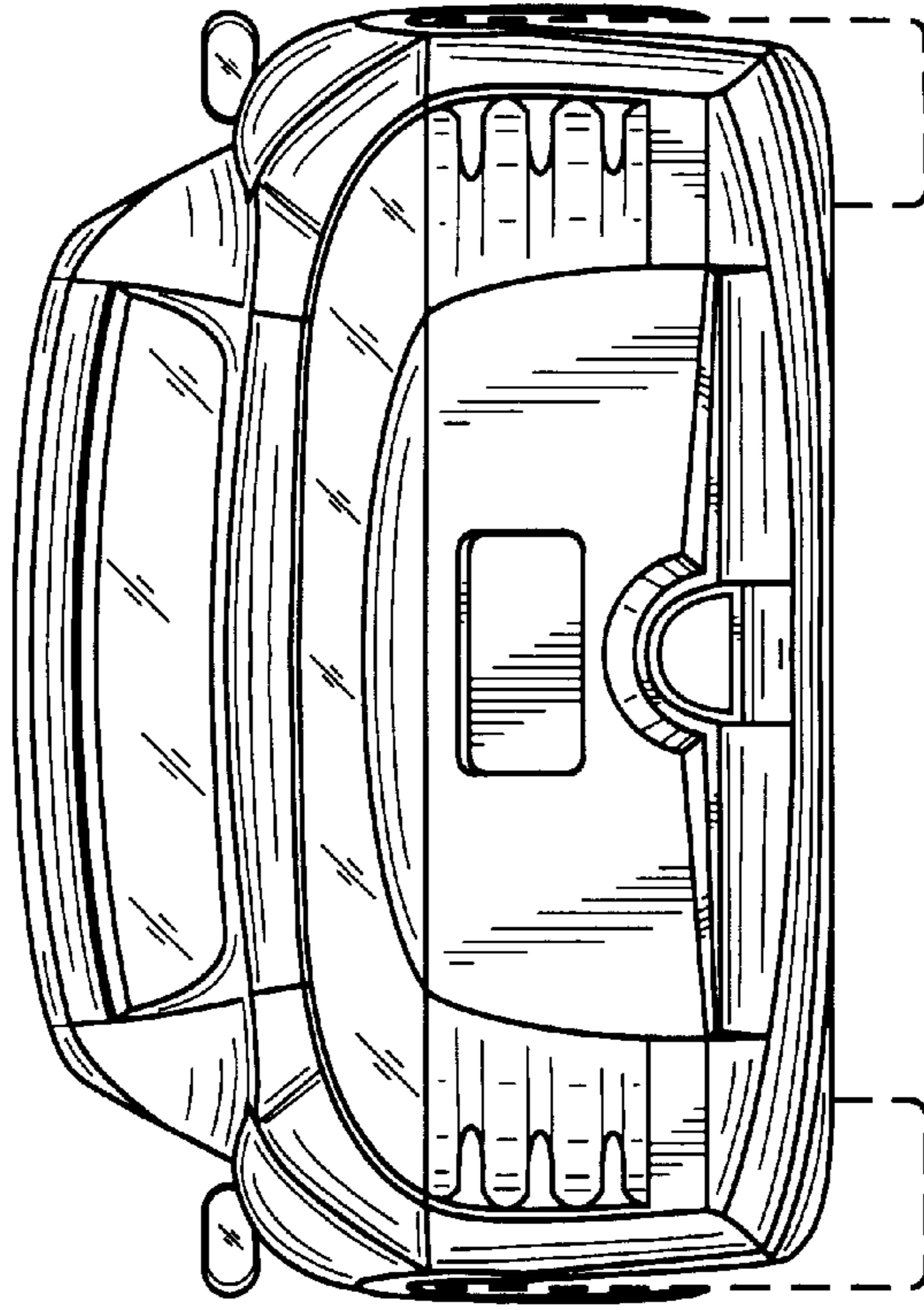

FIG. 3

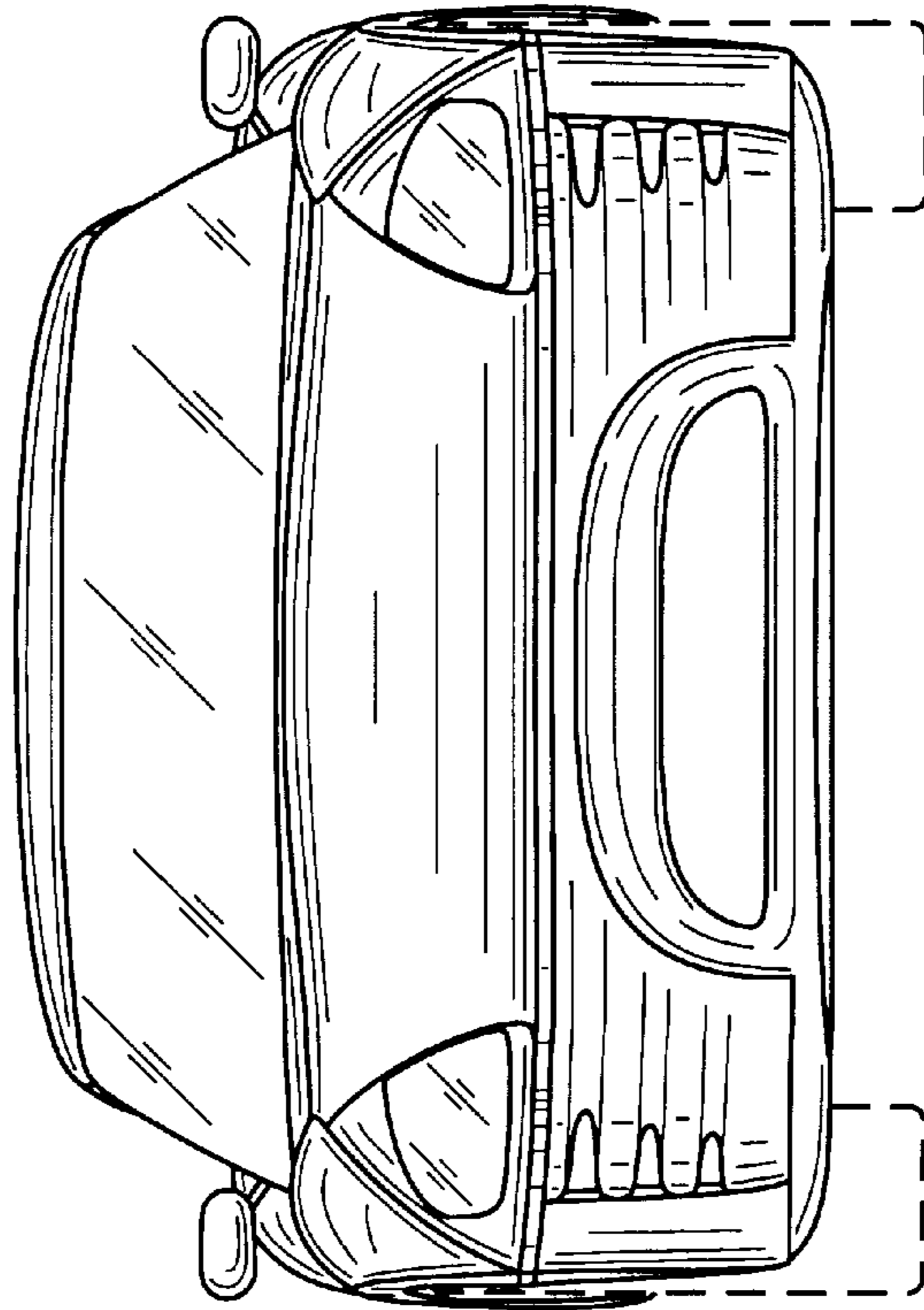

FIG. 4

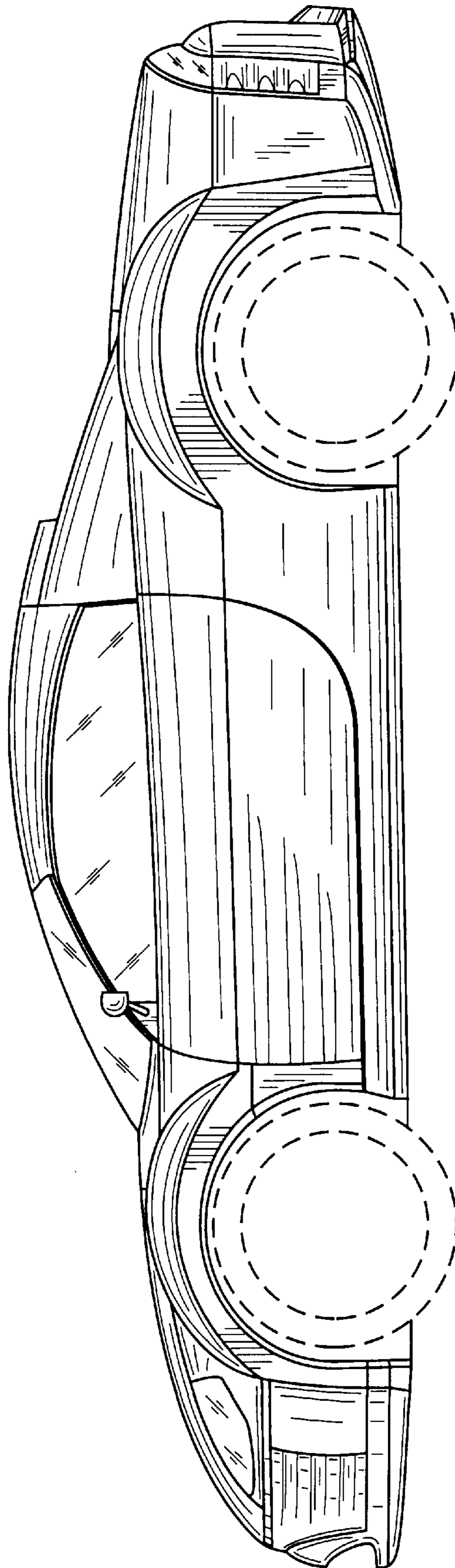

FIG. 5

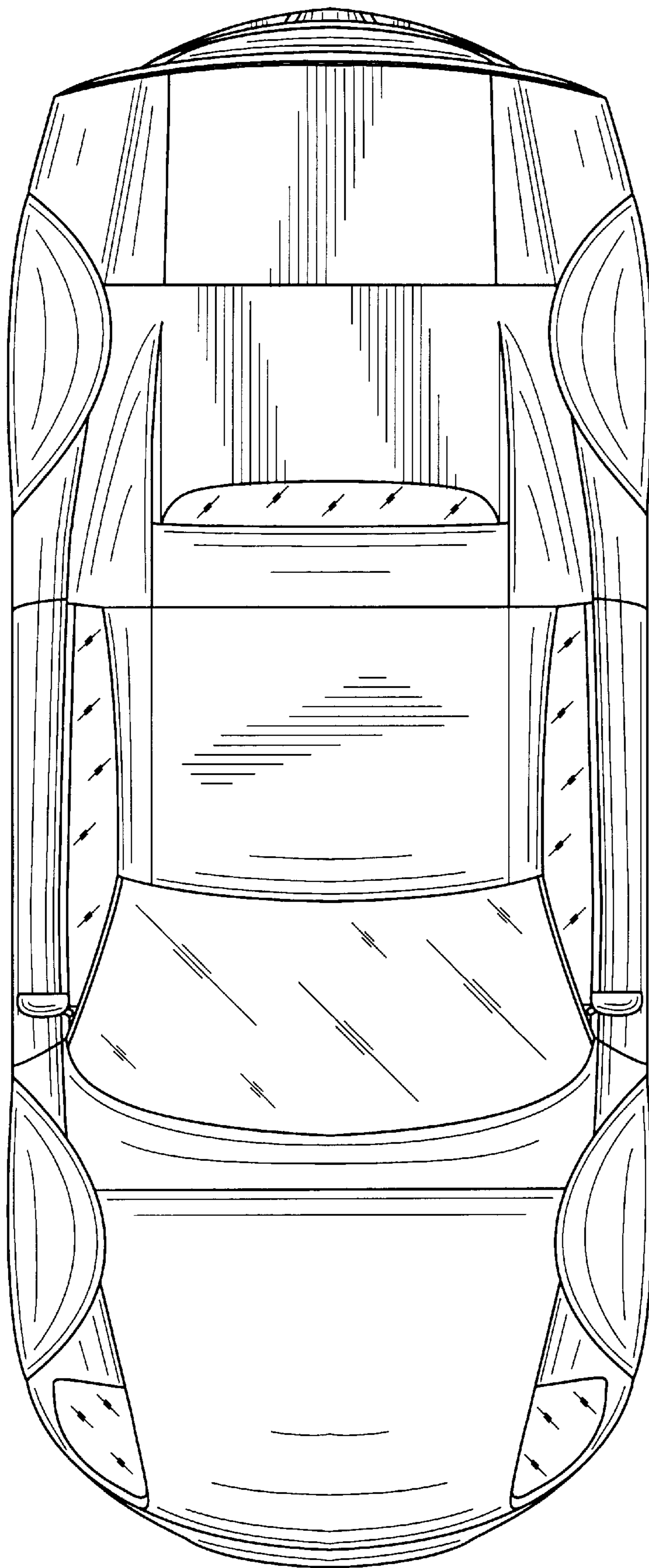

FIG. 6

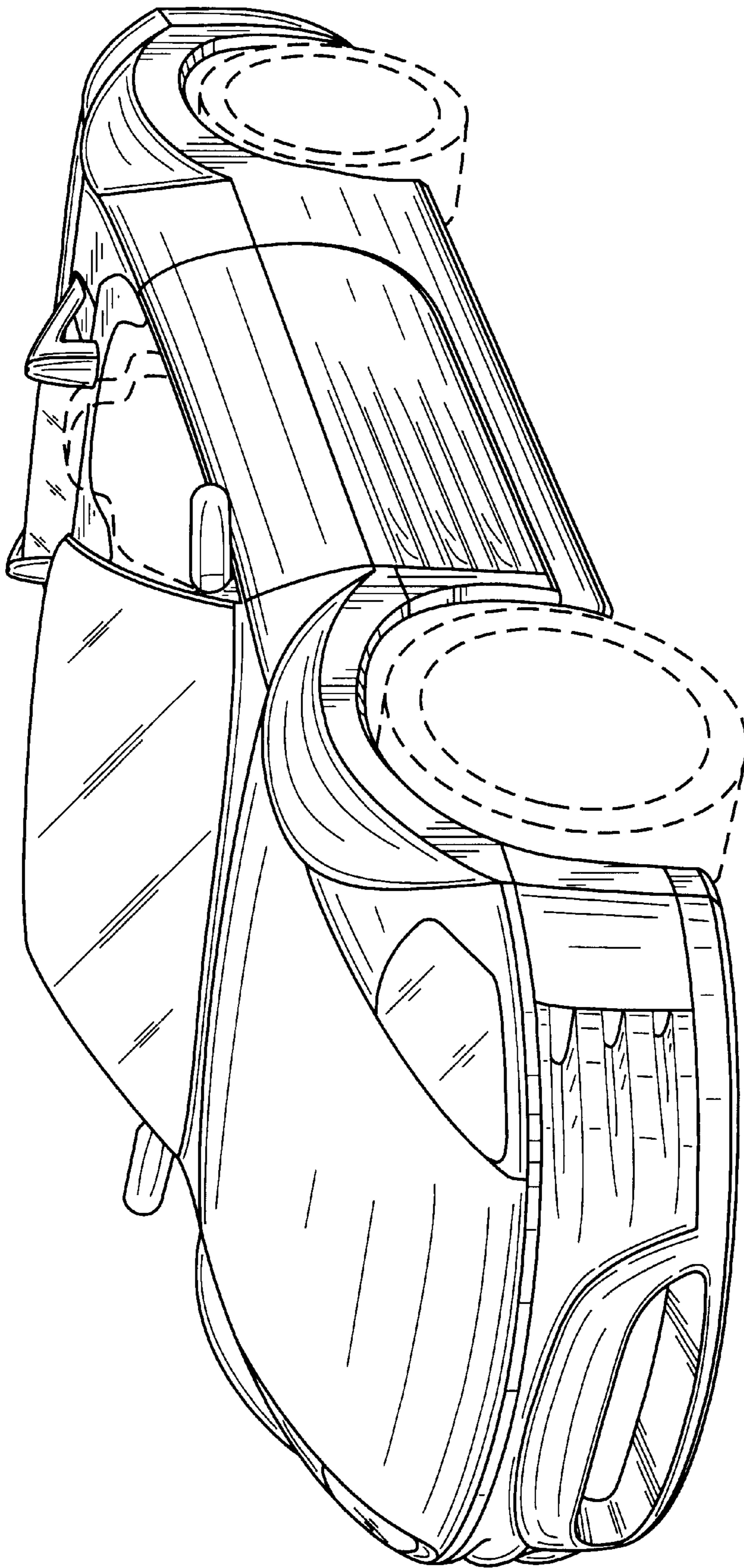

FIG. 7

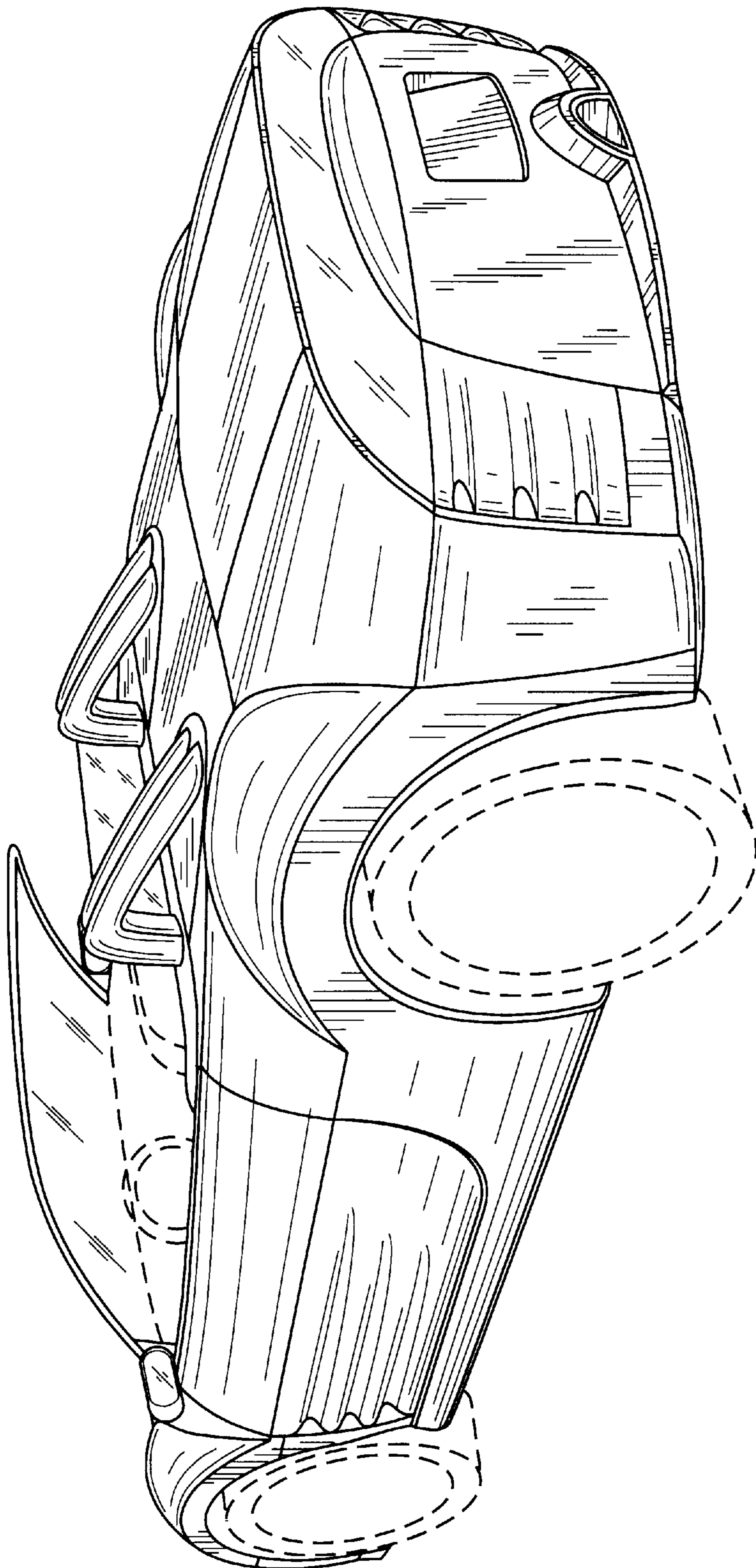

FIG. 8

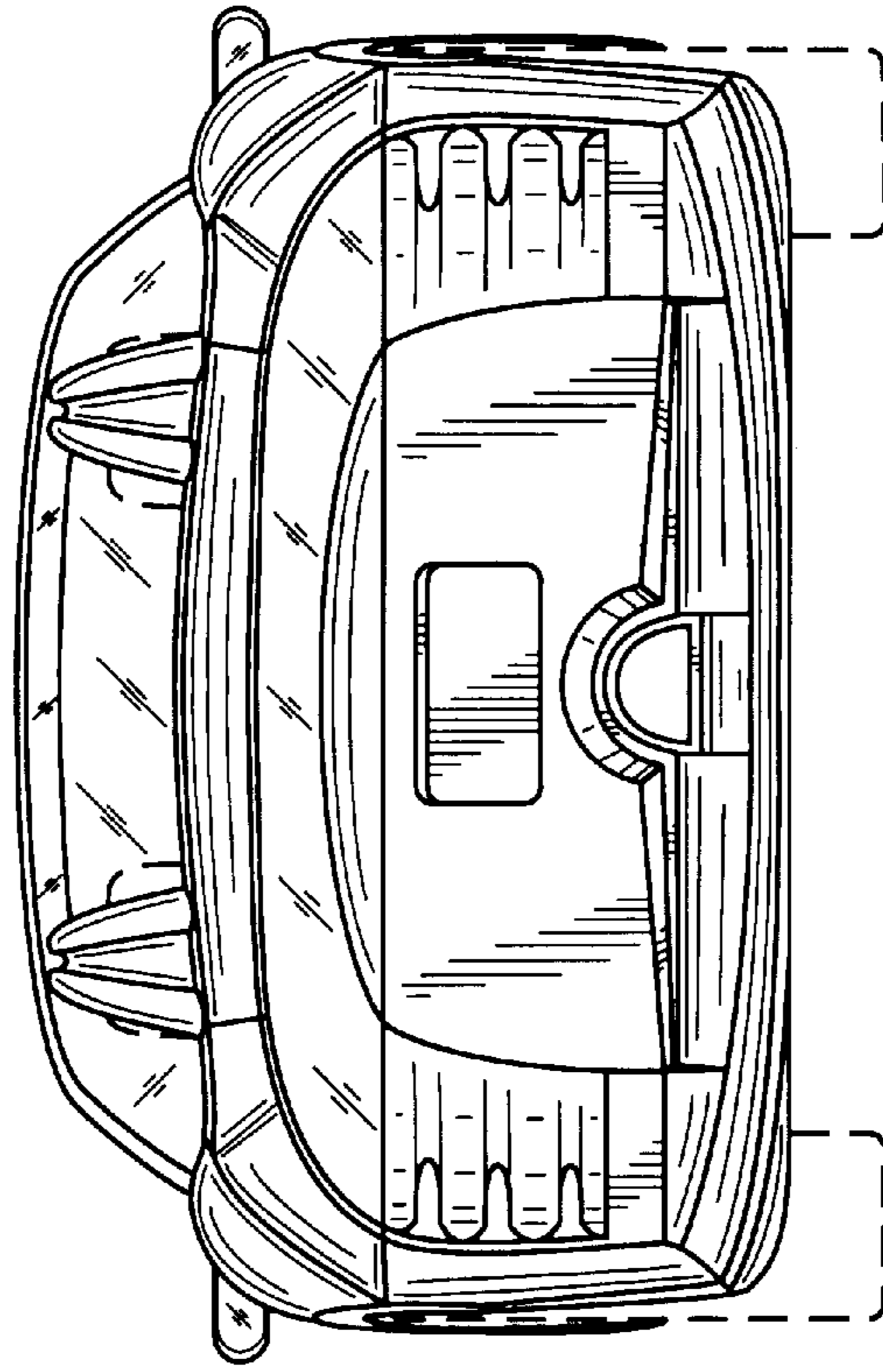

FIG. 9

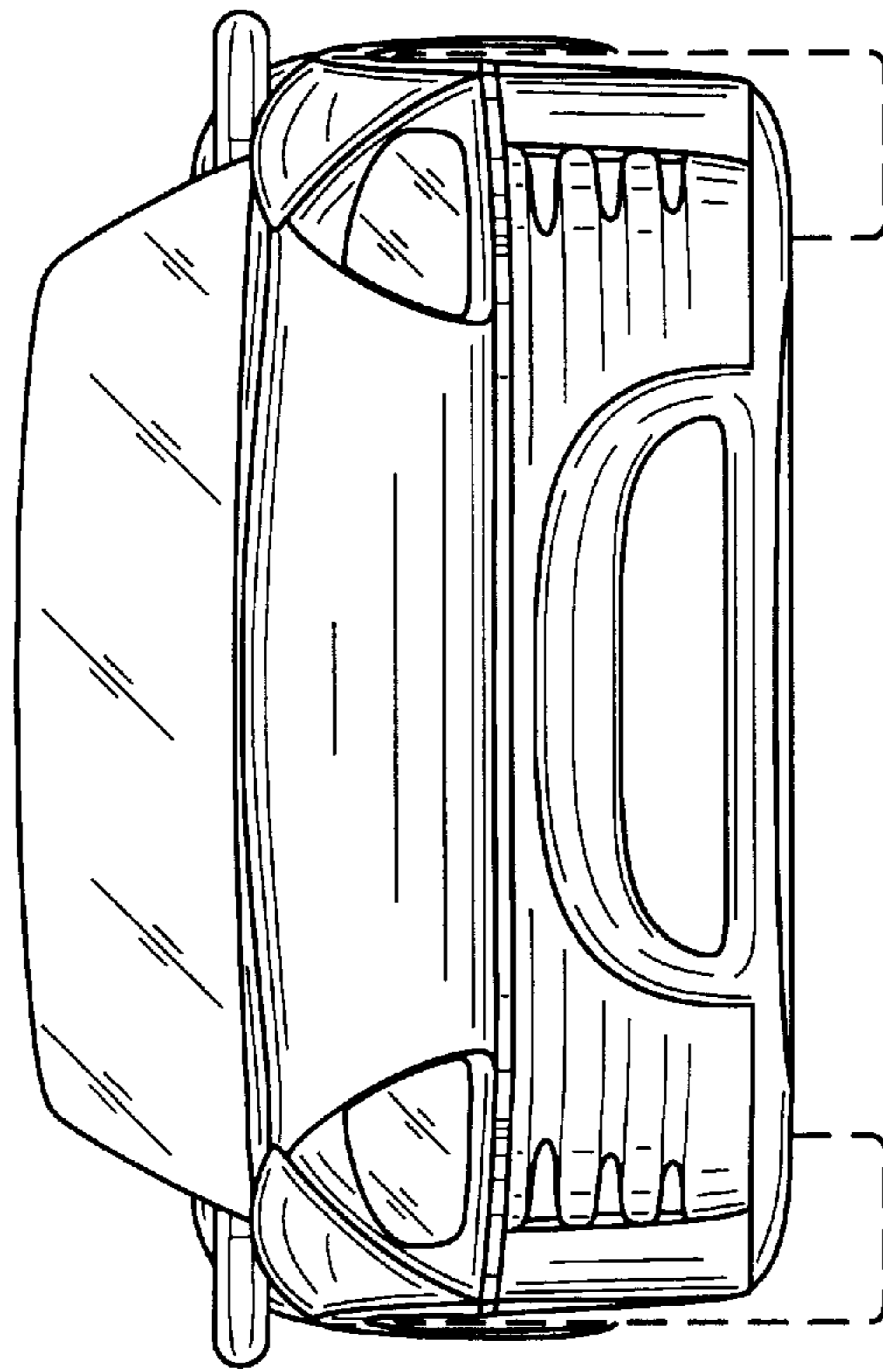

FIG. 10

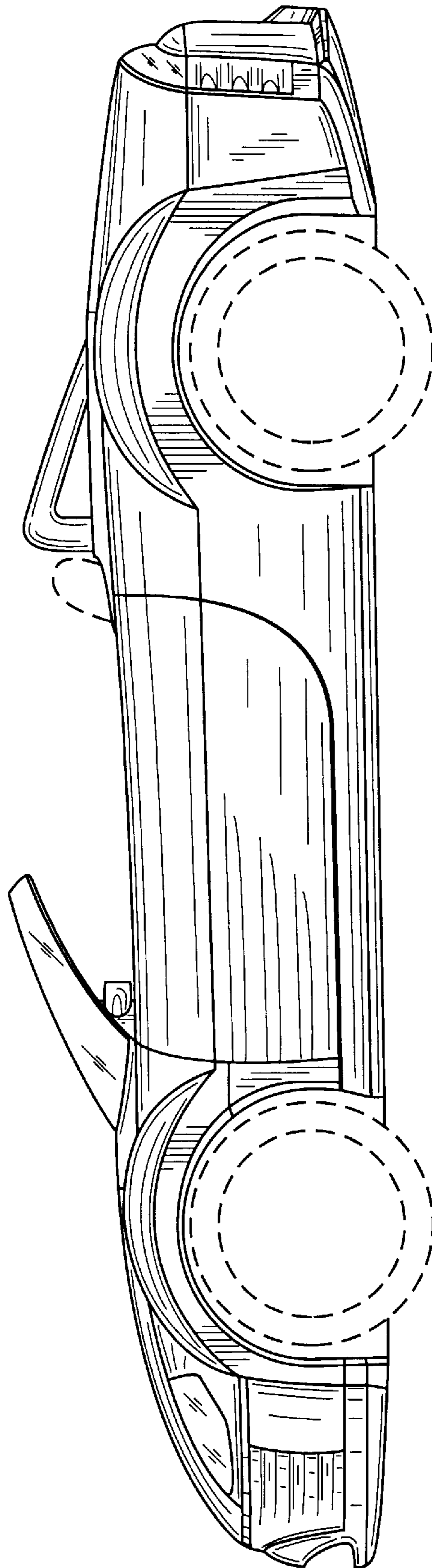

FIG. 11

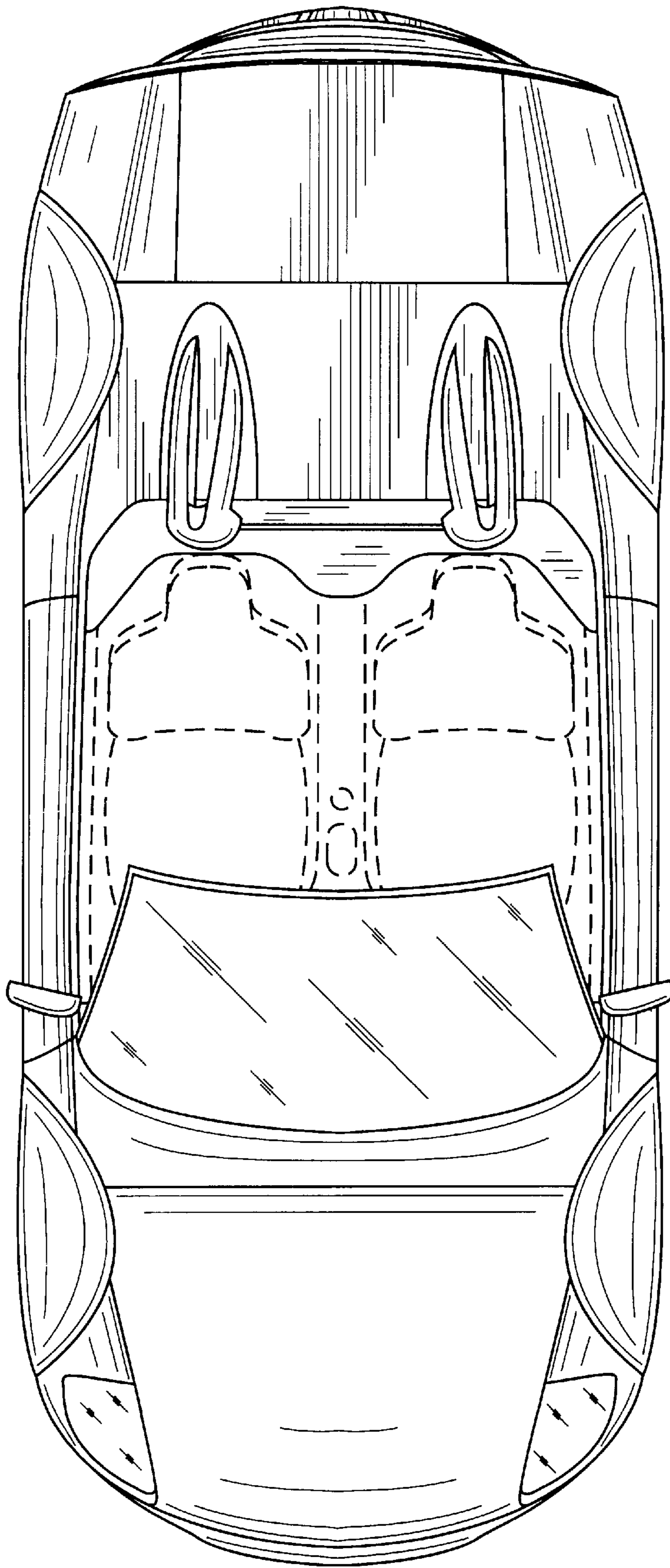

FIG. 12

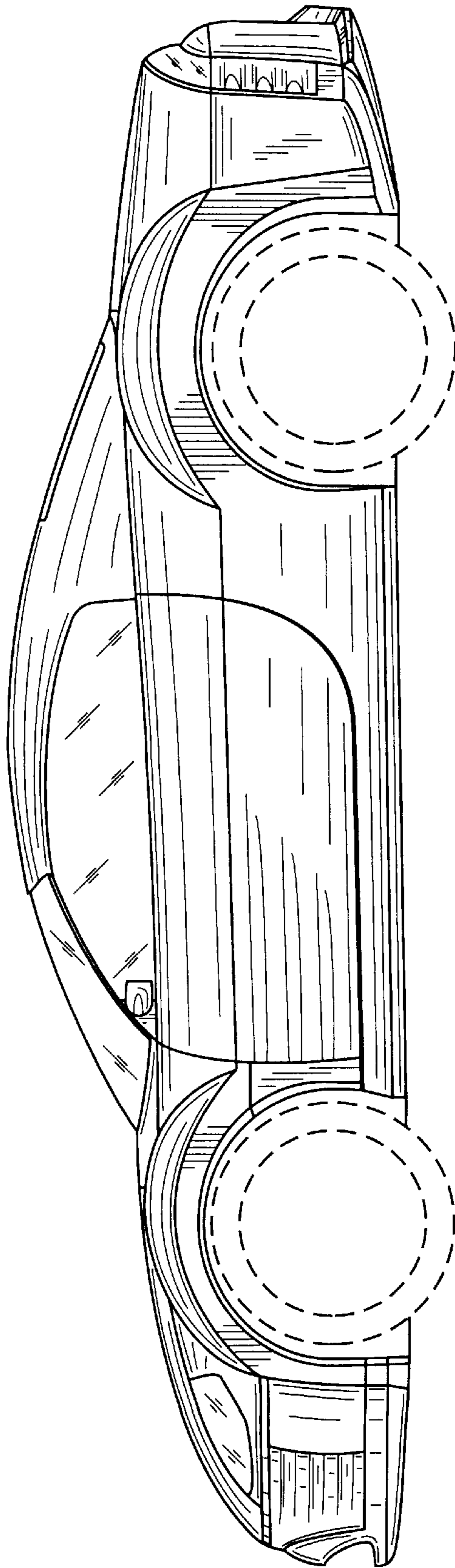

FIG. 13