



US00D425446S

# United States Patent [19] Schnell

[11] Patent Number: Des. 425,446

[45] Date of Patent: \*\* May 23, 2000

[54] AIRPORT VEHICLE

[75] Inventor: Jeffrey W. Schnell, Chippewa Falls, Wis.  
[73] Assignee: Wollard Airport Equipment, Inc., Eau Claire, Wis.  
[\*\*] Term: 14 Years

[21] Appl. No.: 29/111,355  
[22] Filed: Sep. 24, 1999

[51] LOC (7) Cl. .... 12-13  
[52] U.S. Cl. .... D12/14  
[58] Field of Search ..... D12/1, 14, 96-99;  
296/183, 190.01, 197, 181; 180/311, 234

[56] References Cited

U.S. PATENT DOCUMENTS

D. 176,040	11/1955	Schafner et al. ....	D14/3
D. 315,325	3/1991	Legueu .....	D12/96
D. 327,456	6/1992	Sacco et al. ....	D12/96
D. 349,265	8/1994	Patton .....	D12/14
2,494,945	1/1950	Huntington .....	180/71
3,451,571	6/1969	Brisson .....	214/516
3,580,611	5/1971	McNitt .....	280/433
3,894,749	7/1975	Kozuh .....	280/106 R
4,328,988	5/1982	Patterson et al. ....	296/183 X
4,449,748	5/1984	Fiala et al. ....	296/183
4,613,183	9/1986	Kesling .....	296/183
5,082,082	1/1992	Hvolka .....	180/234
5,131,714	7/1992	Evans et al. ....	296/183
5,301,997	4/1994	Cudden .....	296/183

OTHER PUBLICATIONS

NMC/Wollard, Model 100 Tow Tractor sales brochure, 2 pages (no date).  
Wollard TWS-402 Portable Water Service Truck brochure, 2 pages (no date).  
GSE (Ground Support Equipment) Today, Jul. 1997, pp. 38-40.  
Undated two-page sales brochure featuring Lift-A-Loft product (no date).  
NMC/Wollard sales brochure, 2 pages (no date).

Primary Examiner—Doris V. Coles  
Assistant Examiner—Stacia Cadmus  
Attorney, Agent, or Firm—Anthony J. Bourget

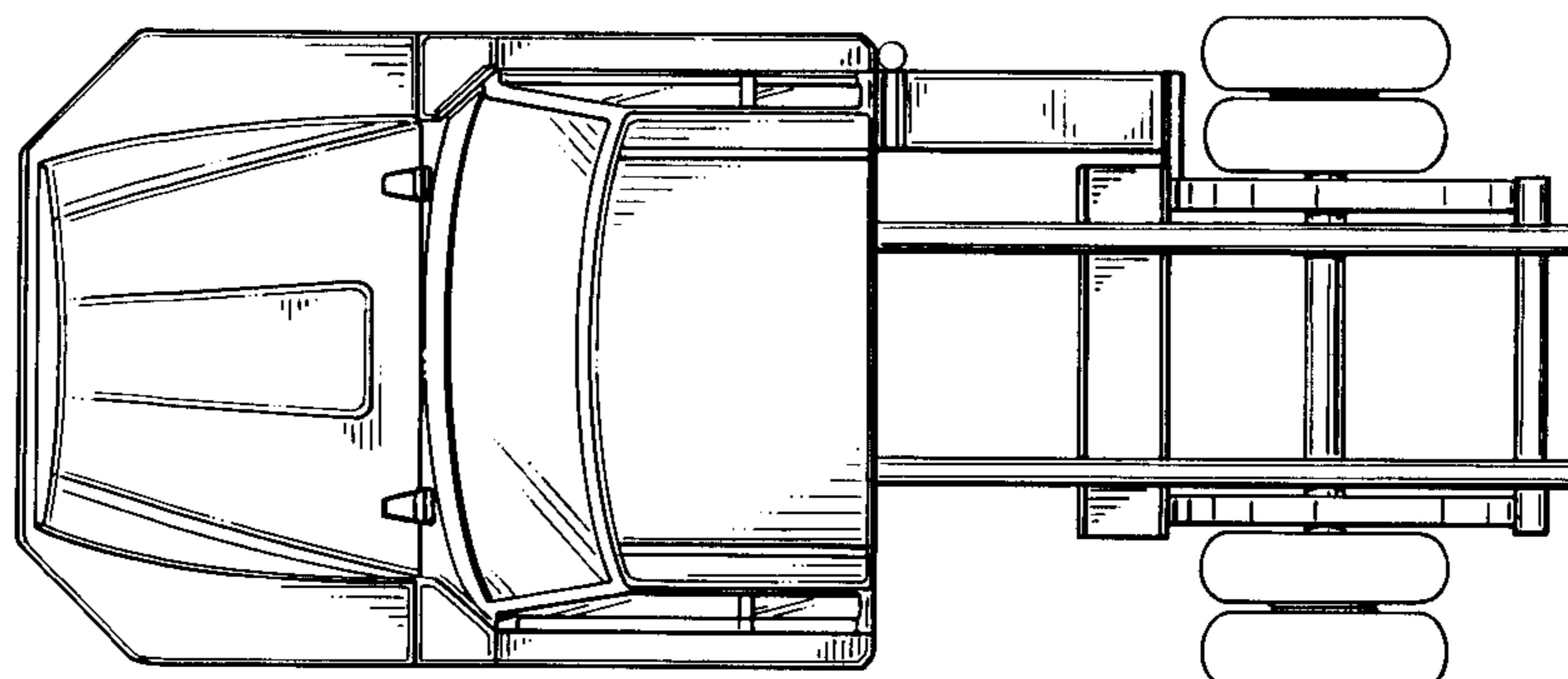
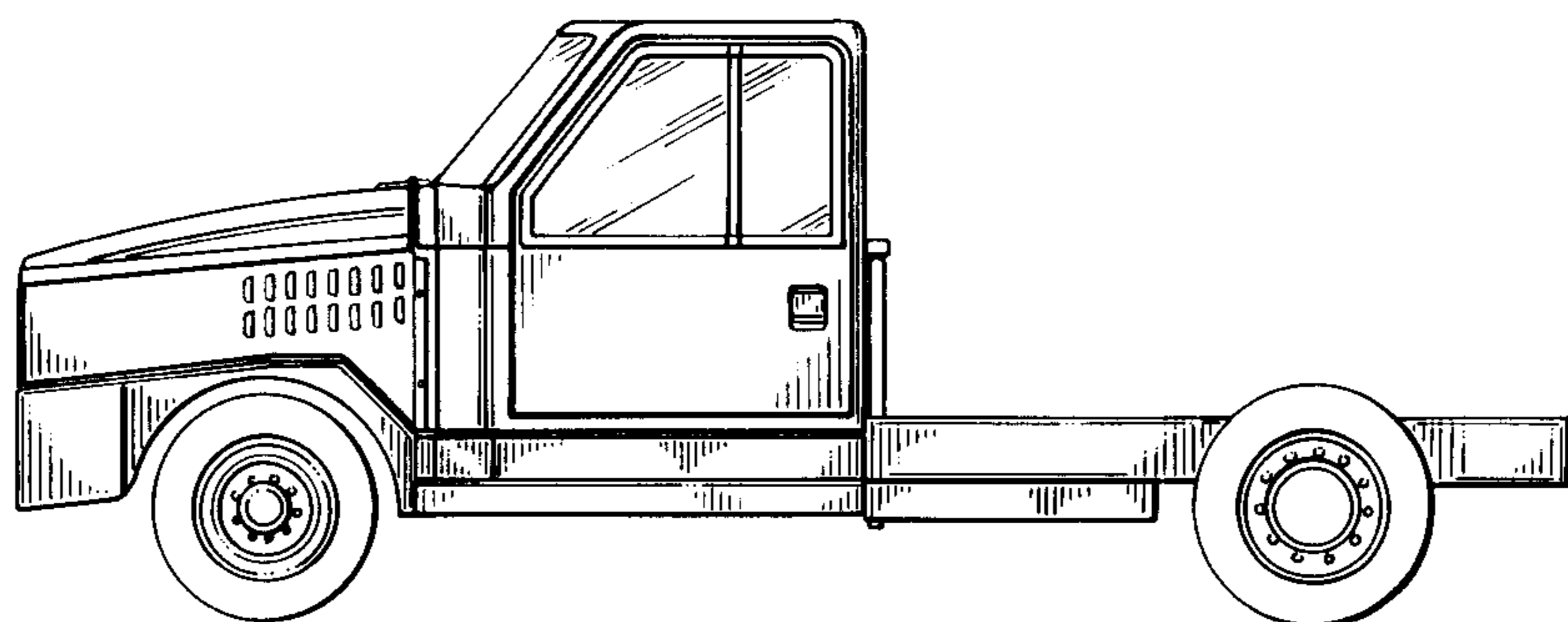
[57] CLAIM

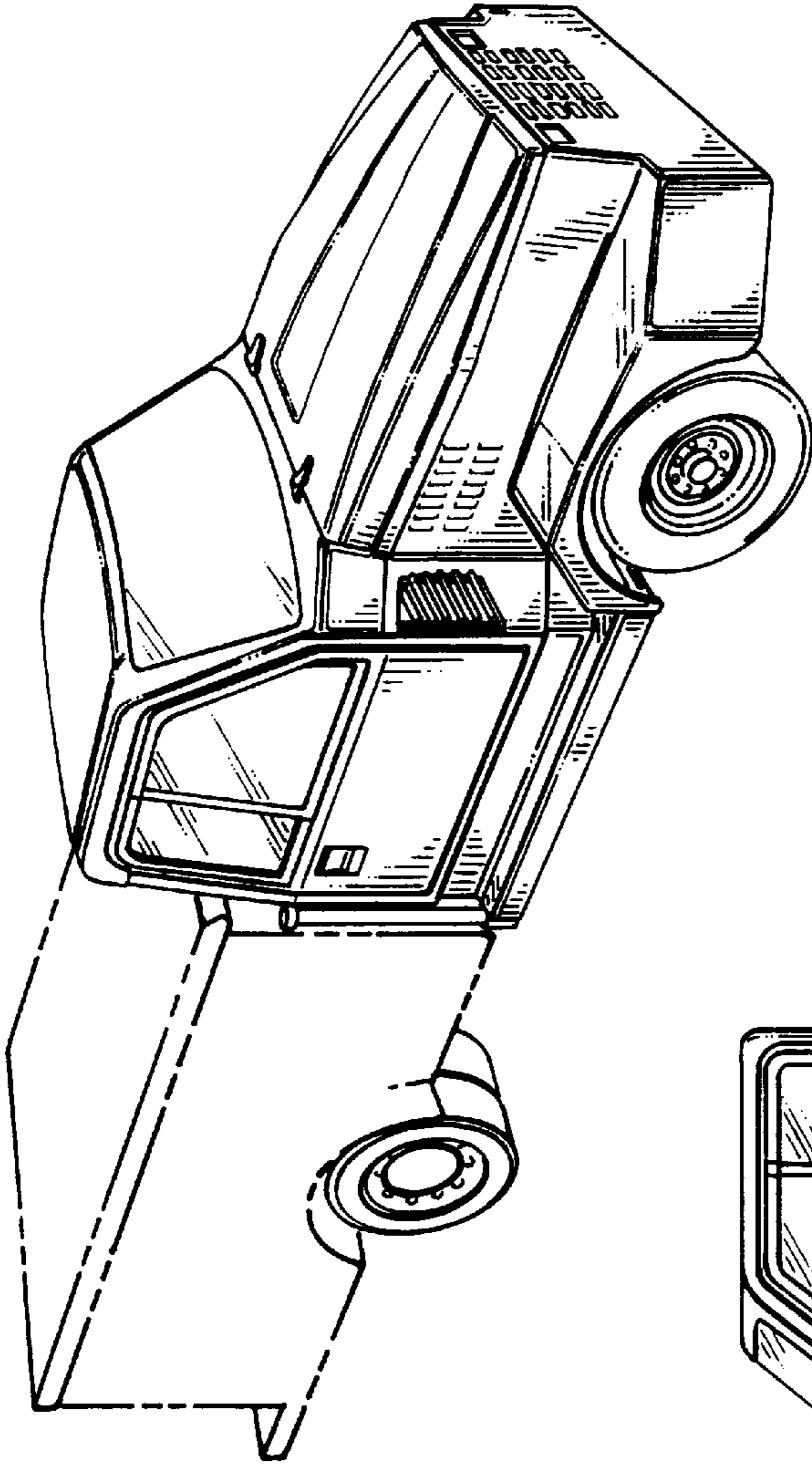
The ornamental design for an airport vehicle, as shown and described.

DESCRIPTION

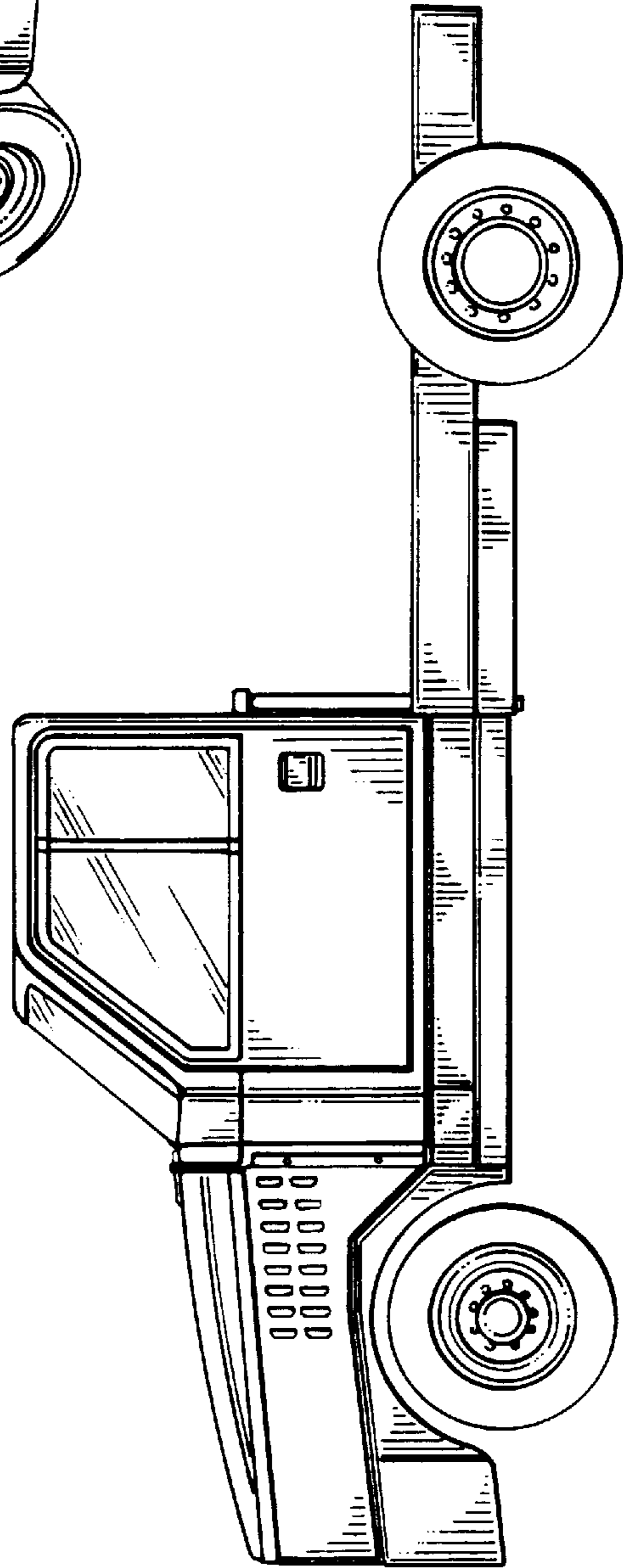
FIG. 1 is a front perspective view of an airport vehicle showing my new design;  
FIG. 2 is a left elevational view thereof;  
FIG. 3 is a right elevational view thereof;  
FIG. 4 is a front elevational view thereof;  
FIG. 5 is a rear elevational view thereof; and,  
FIG. 6 is a top plan view thereof.  
The broken line showing of environment in FIG. 1 is for illustrative purposes only and forms no part of the claimed design.

1 Claim, 3 Drawing Sheets

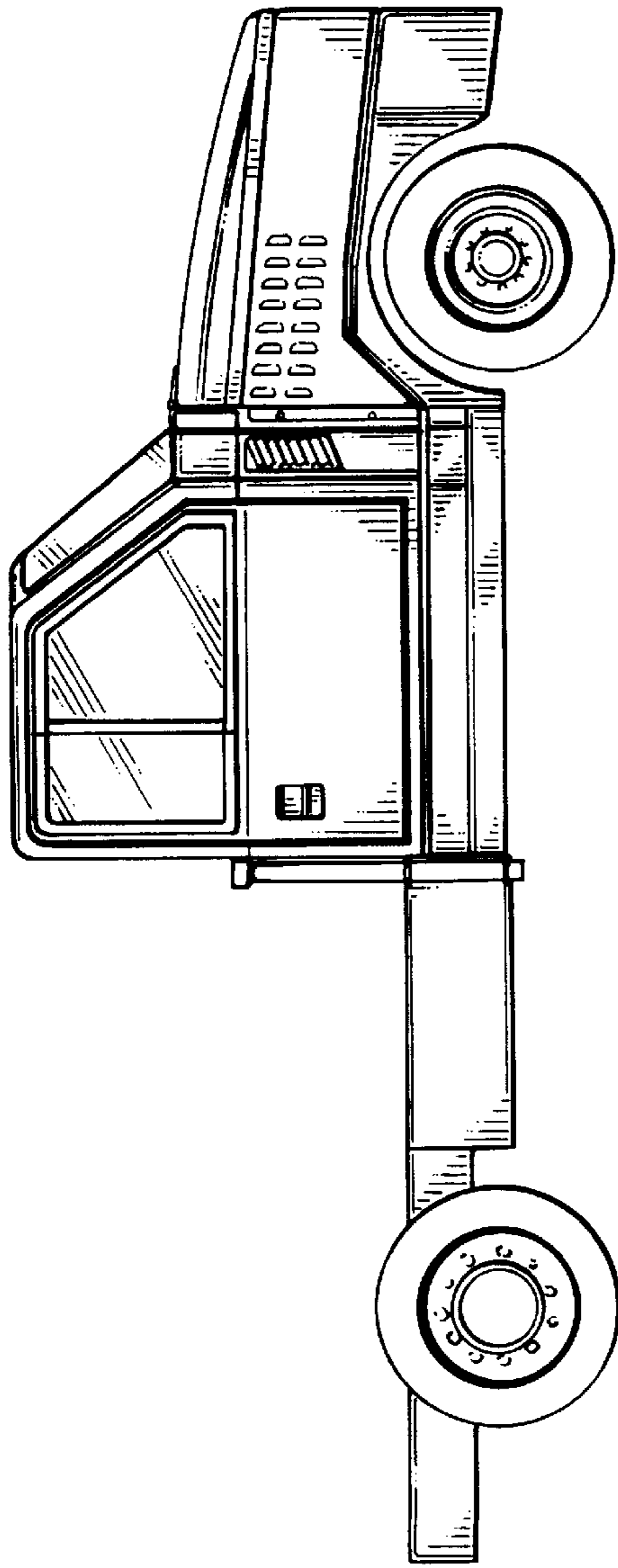




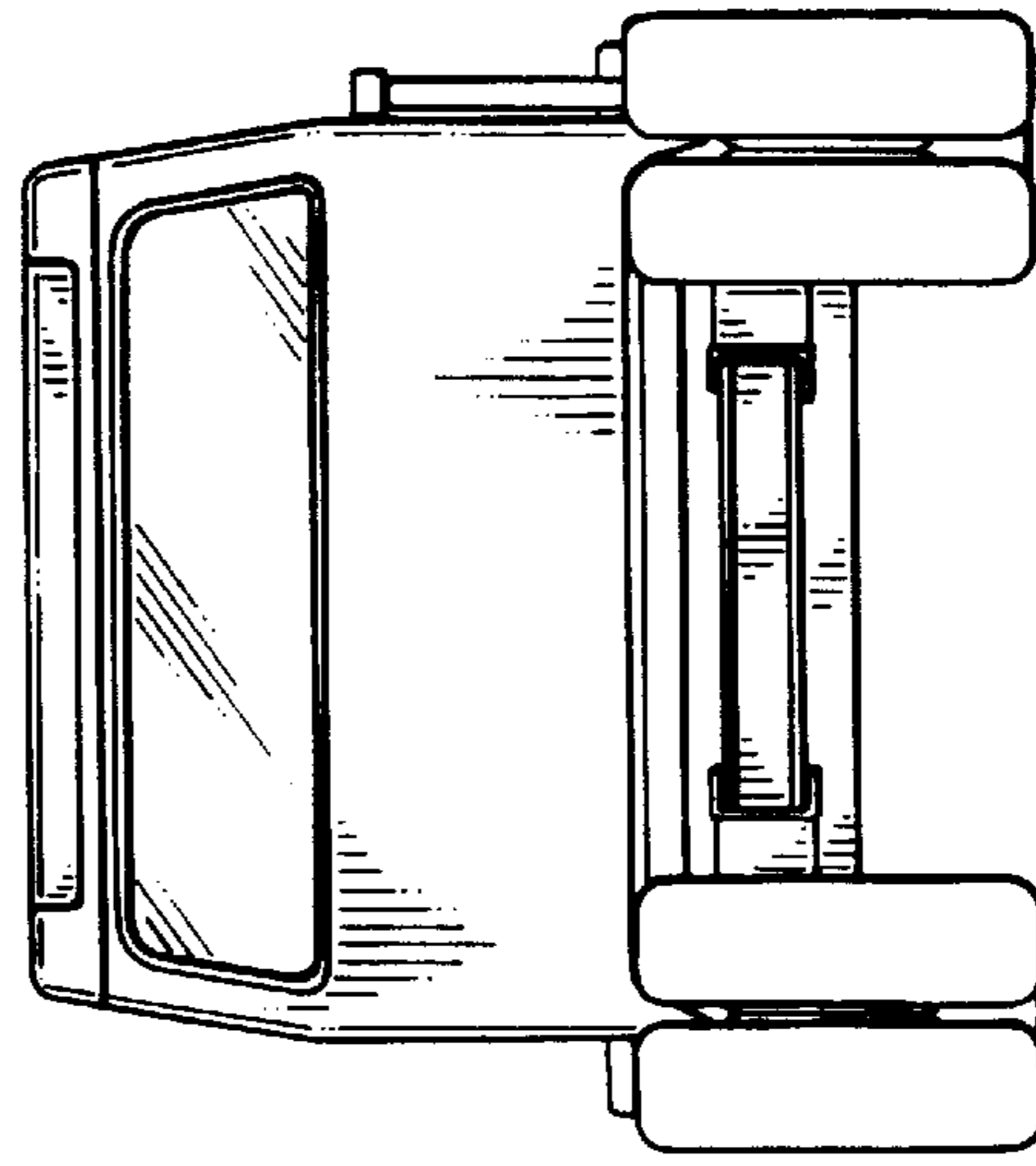
**Fig. 1**



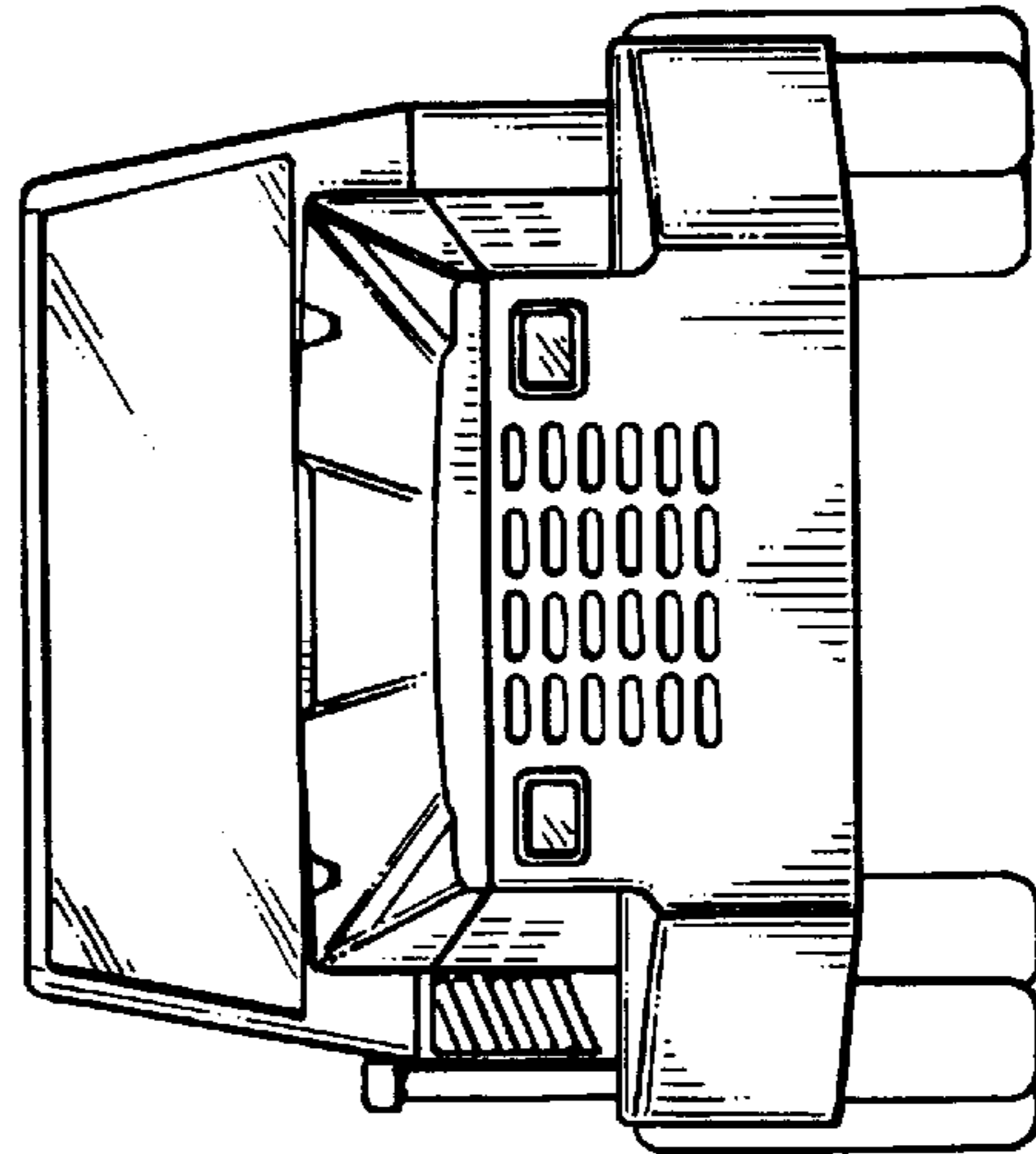
**Fig. 2**



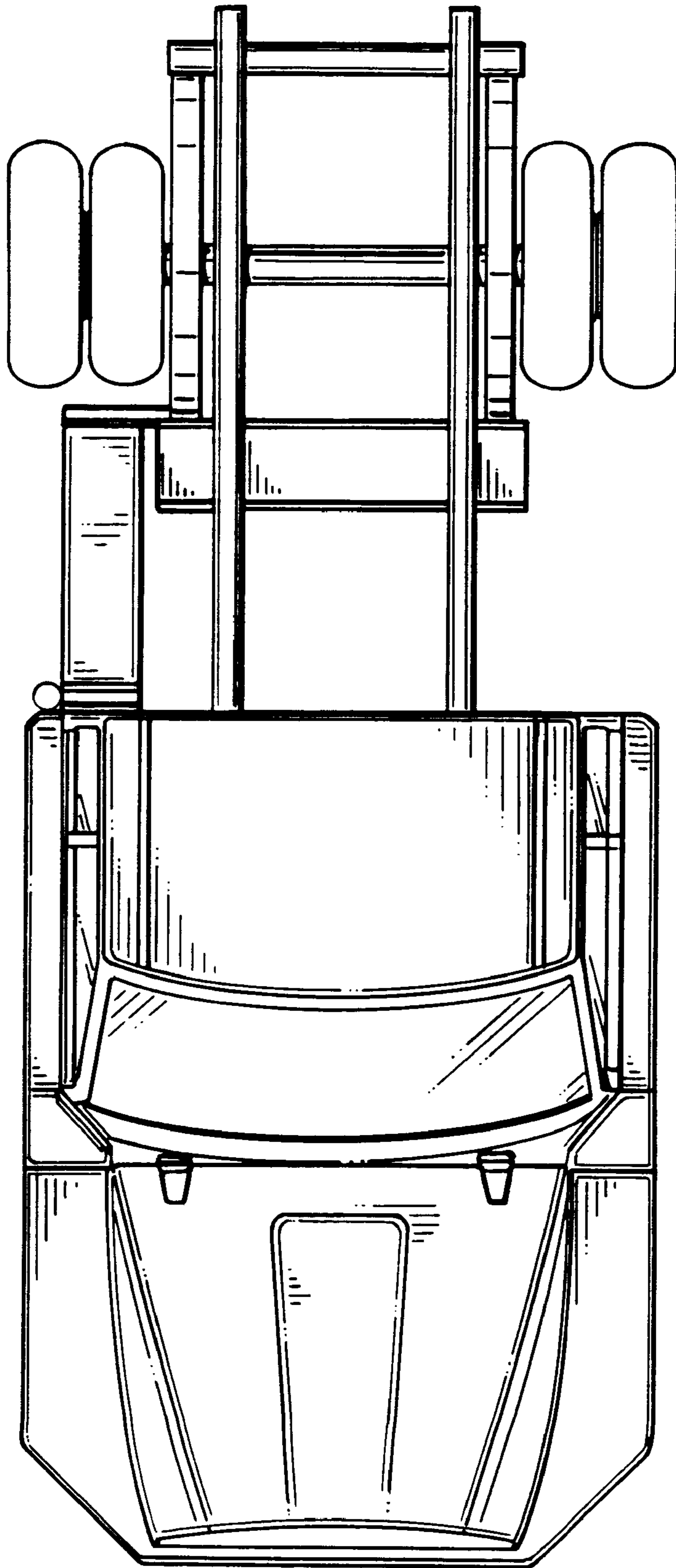
**Fig. 3**



**Fig. 5**



**Fig. 4**



**Fig. 6**