



US00D425224S

United States Patent [19]
Macri

[11] **Patent Number: Des. 425,224**

[45] **Date of Patent: ** May 16, 2000**

[54] **VEHICLE INTERIOR LAMP ASSEMBLY
ADAPTED FOR USE WITH RECREATIONAL
VEHICLES, OUTFITTED VANS,
SHUTTLEBUSES AND THE LIKE**

Primary Examiner—Susan J. Lucas
Attorney, Agent, or Firm—Van Dyke, Gardner, Linn &
Burkhart, LLP

[75] **Inventor: Gregory G. Macri, Elkhart, Ind.**

[57] **CLAIM**

The ornamental design for the vehicle interior lamp assembly adapted for use with recreational vehicles, outfitted vans, shuttlebuses and the like, as shown and described.

[73] **Assignee: ASC Industries, Inc., Elkhart, Ind.**

[**] **Term: 14 Years**

DESCRIPTION

[21] **Appl. No.: 29/105,971**

FIG. 1 is a front, top and left end perspective view of a vehicle interior lamp assembly adapted for use with recreational vehicles, outfitted vans, shuttlebuses and the like, according to the invention;

[22] **Filed: Jun. 4, 1999**

FIG. 2 is a top plan view of FIG. 1;

[51] **LOC (7) Cl. 26-06**

[52] **U.S. Cl. D26/35; D26/36**

FIG. 3 is a front elevation of FIG. 1, the rear elevational view being a mirror image of the view in FIG. 3;

[58] **Field of Search D26/28-36; 362/41,**

362/43, 459, 464, 485, 486, 487, 493, 496,

498, 538, 540, 542; 340/468, 471, 472,

473, 479, 478

FIG. 4 is a left end elevation of FIG. 1, the right end elevation being a mirror image of the view in FIG. 4;

[56] **References Cited**

U.S. PATENT DOCUMENTS

D. 124,607 1/1941 Hutt D26/36

D. 358,674 5/1995 Ramsey D26/28

D. 393,729 4/1998 Tuttle D26/28

3,305,168 2/1967 Ramniceanu 362/253

3,748,458 7/1973 Morrison D26/36 X

5,938,321 8/1999 Bos et al. 362/494

FIG. 5 is a bottom plan view of FIG. 1;

FIG. 6 is a front, top and left end perspective view of an alternative embodiment of a vehicle interior lamp assembly adapted for use with recreational vehicles, outfitted vans, shuttlebuses and the like, according to the invention;

FIG. 7 is a top plan view of FIG. 6;

FIG. 8 is a front elevation of FIG. 6, the rear elevational view being a mirror image of the view of FIG. 8;

FIG. 9 is a right end elevation of FIG. 6;

FIG. 10 is left end elevation of FIG. 6; and,

FIG. 11 is bottom plan view of FIG. 6.

The broken lines are shown for illustrative purposes only and form no part of the claimed design.

OTHER PUBLICATIONS

Three sheets of photographs containing a pictorial representation of a partially disassembled globe type lamp assembly that has been on sale in the United States more than one year before the applicats' filing date.

1 Claim, 4 Drawing Sheets

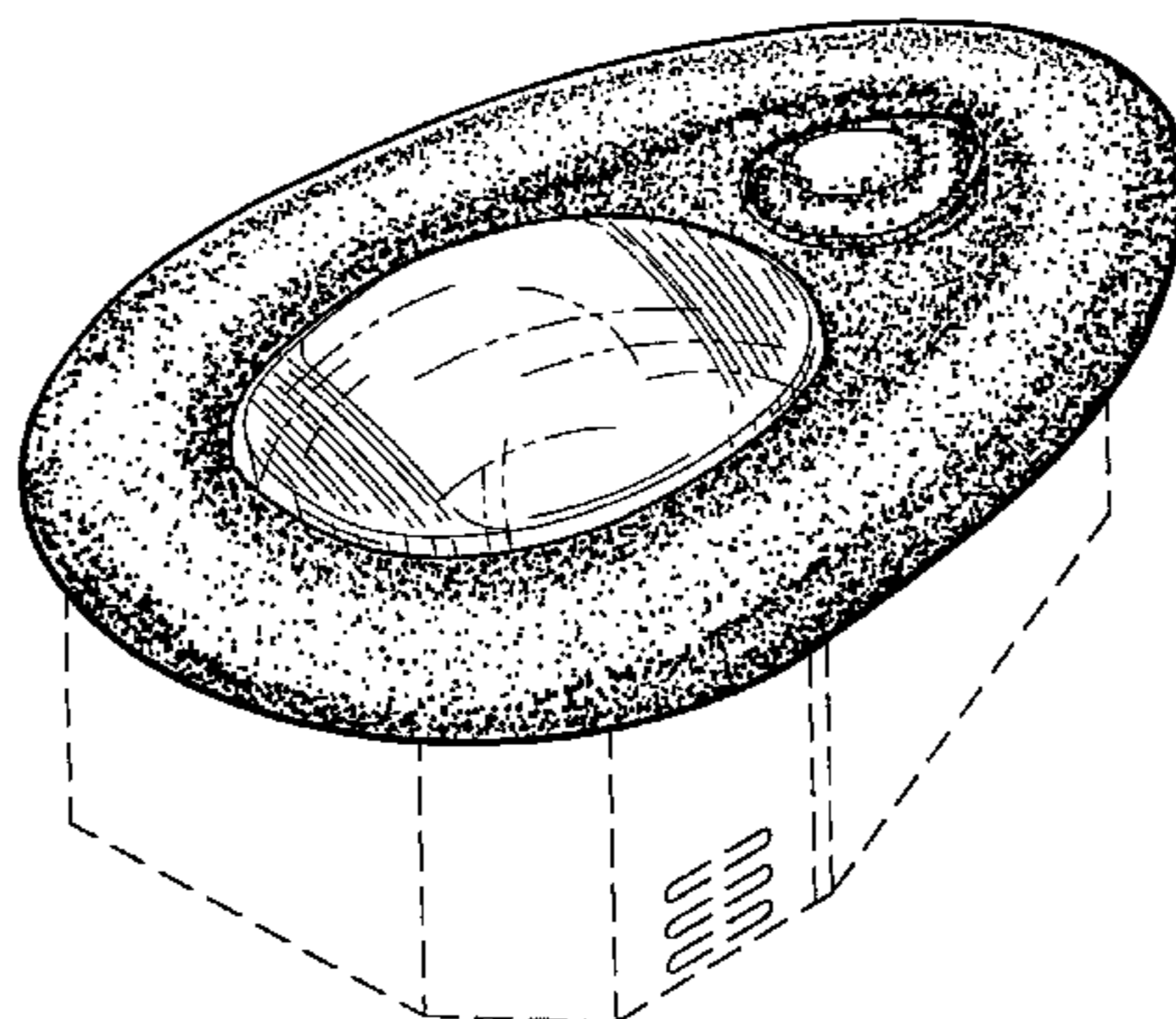
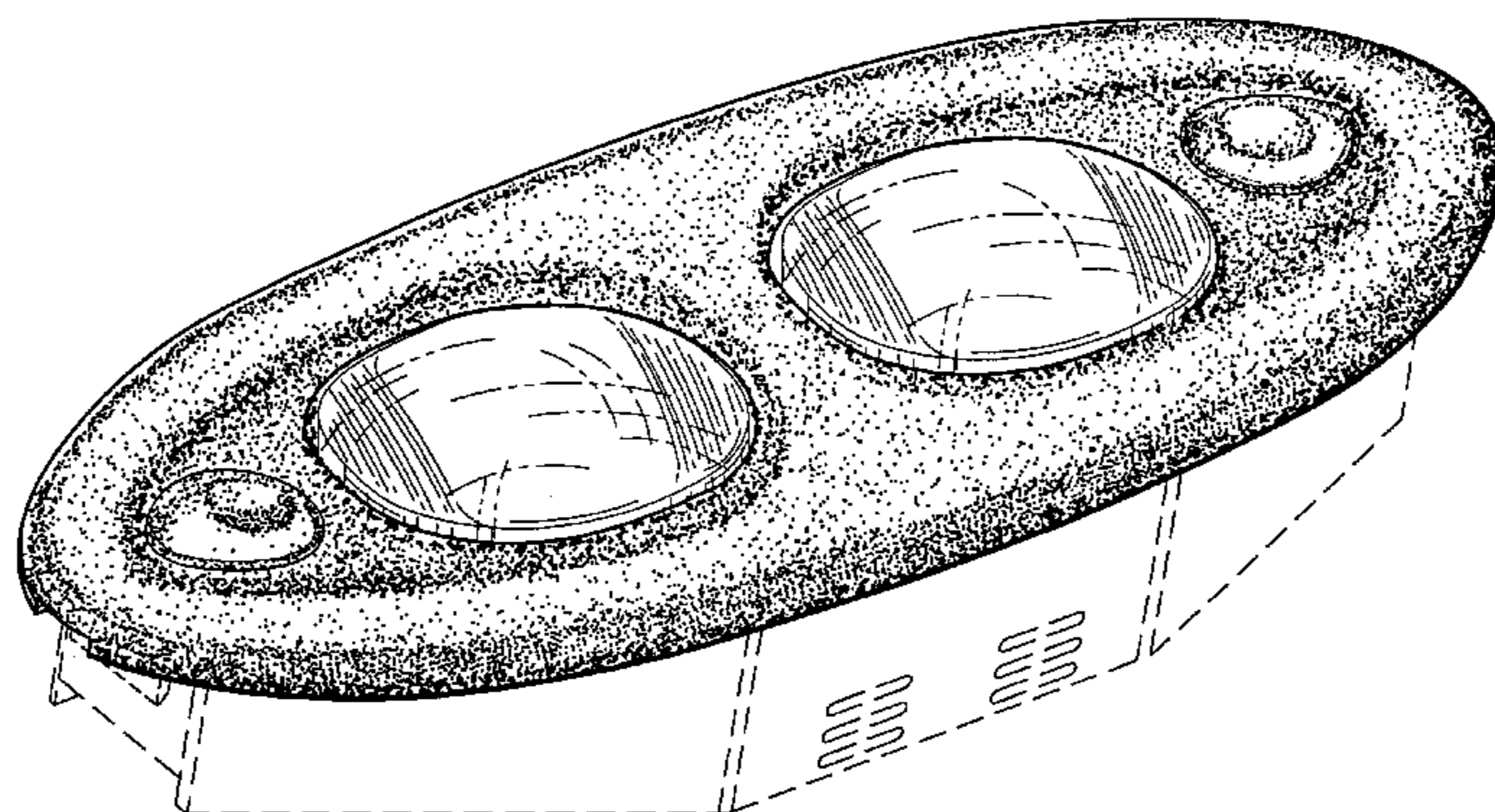

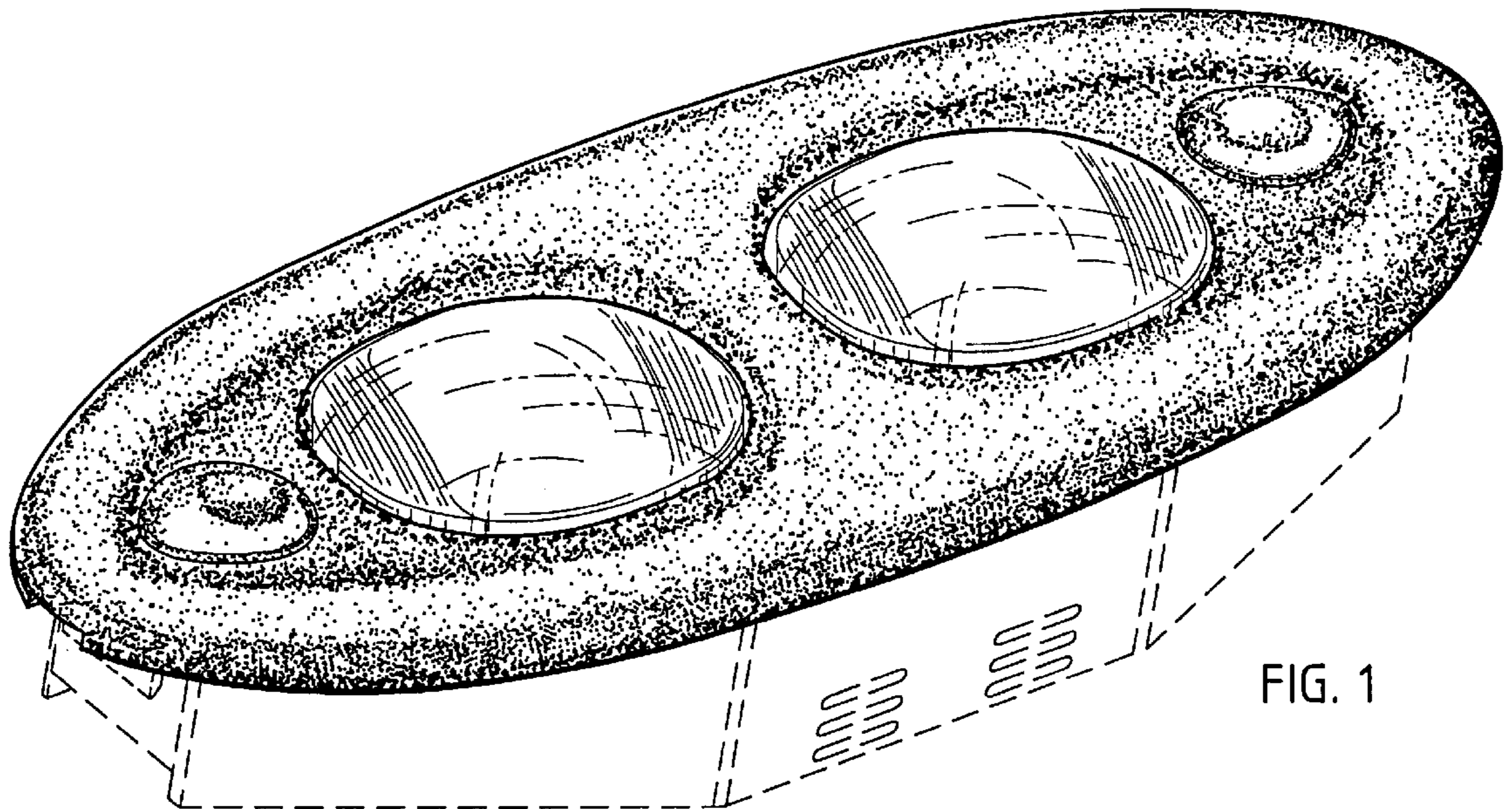

FIG. 1

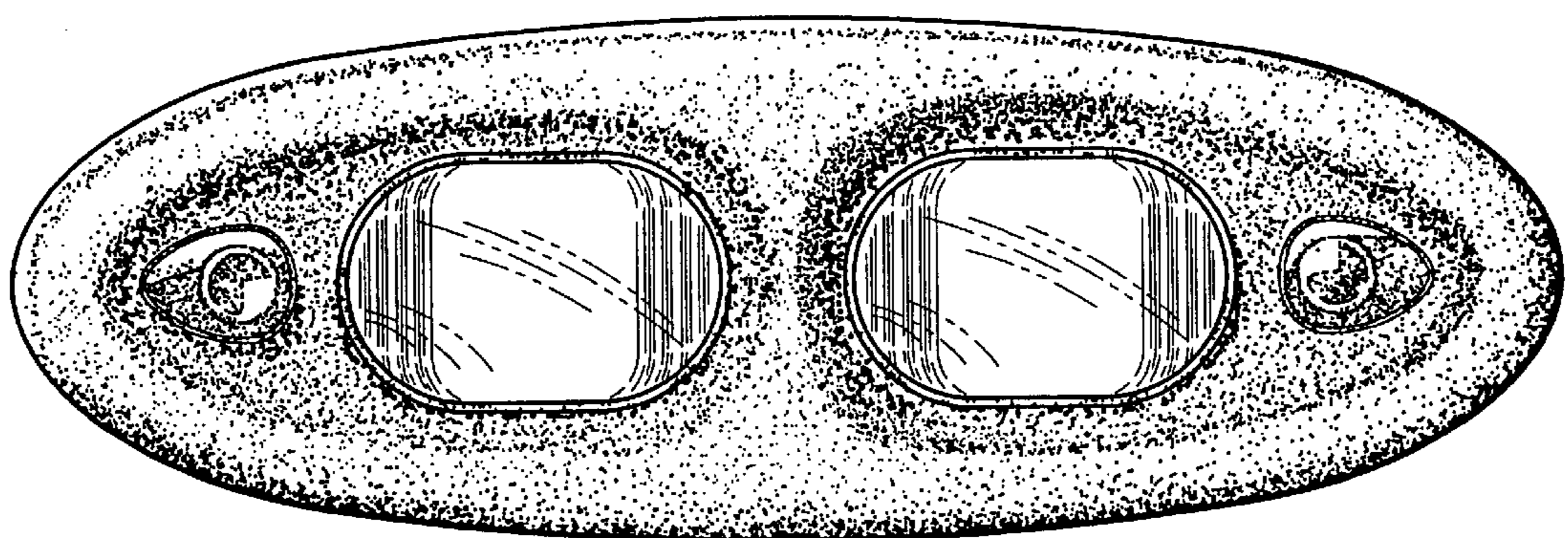

FIG. 2

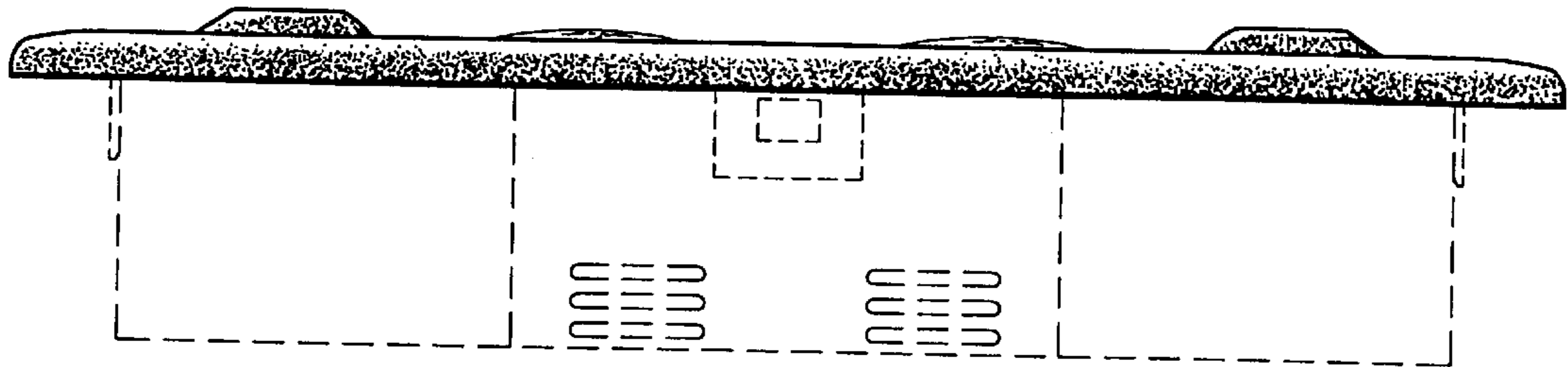

FIG. 3

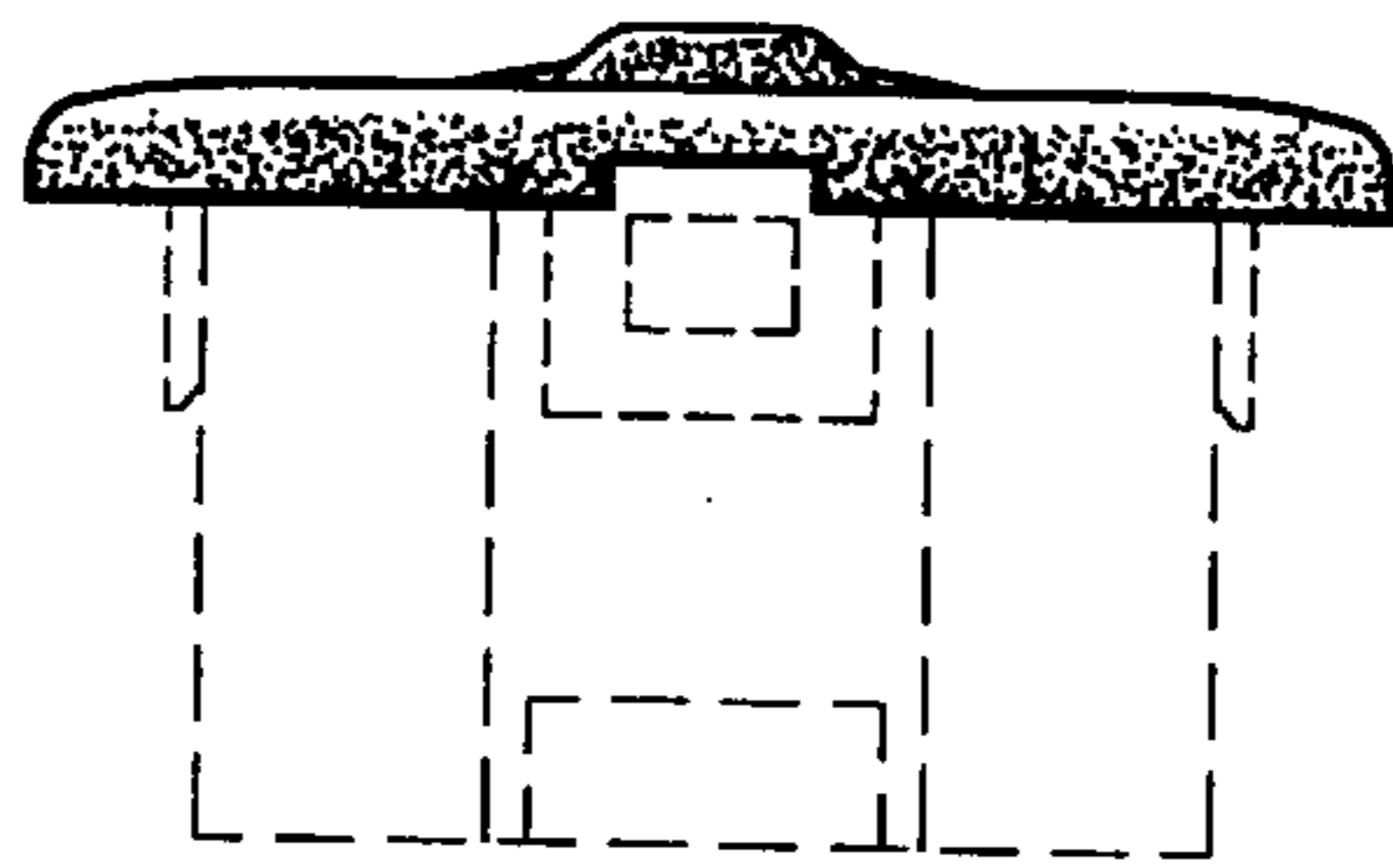

FIG. 4

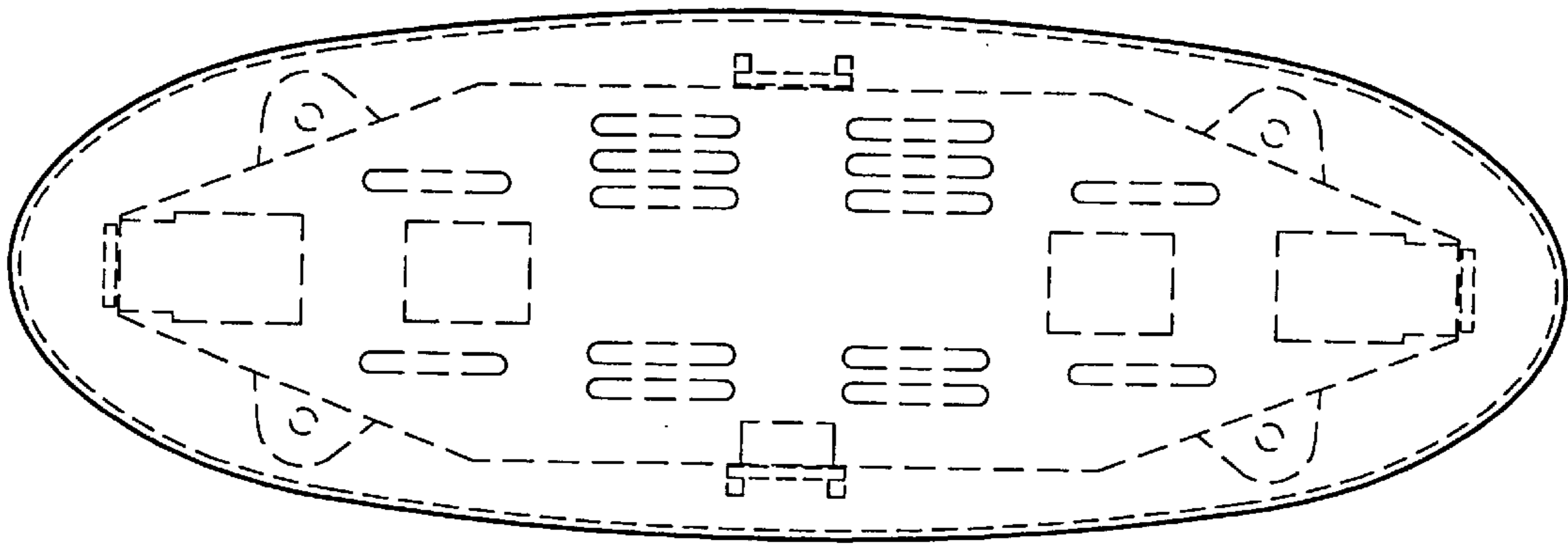

FIG. 5

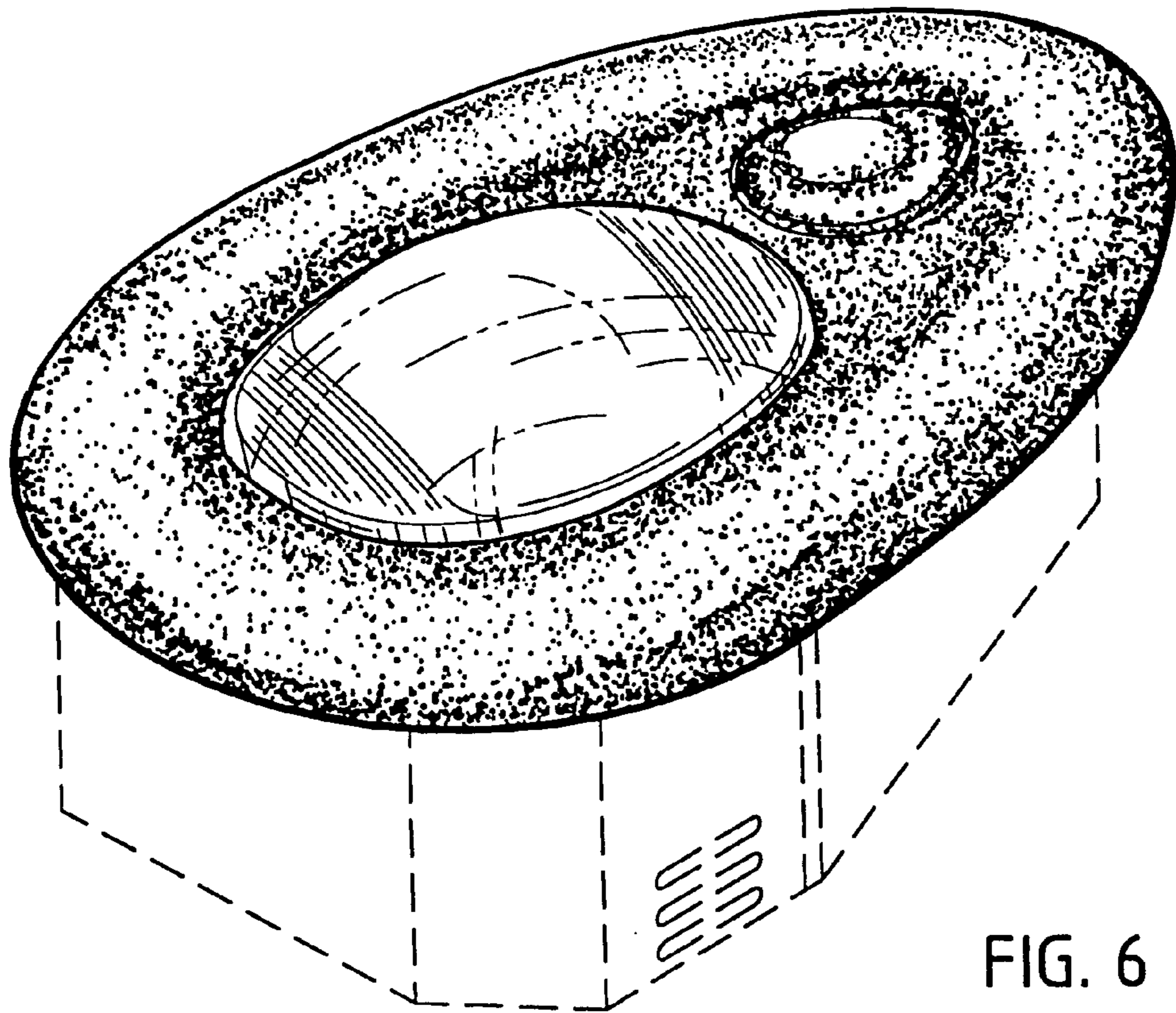

FIG. 6

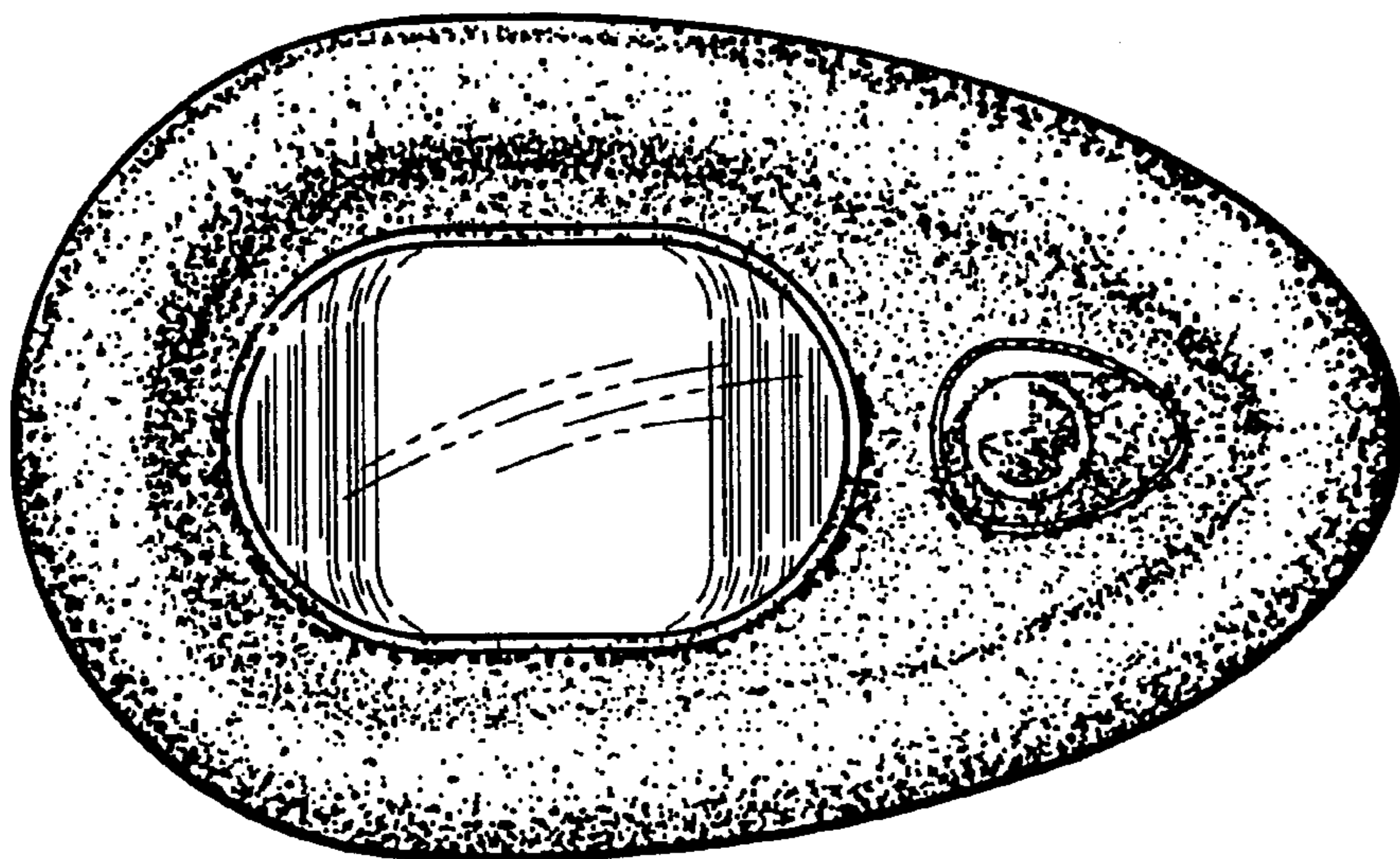

FIG. 7

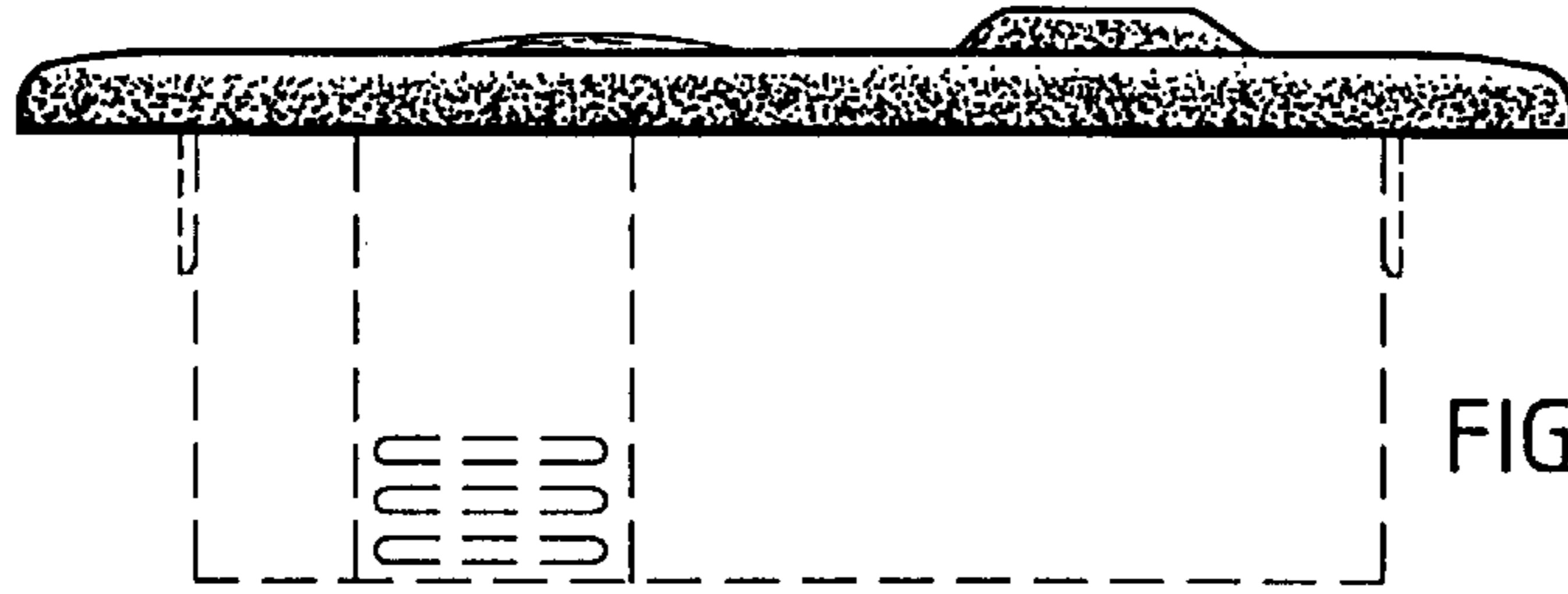

FIG. 8

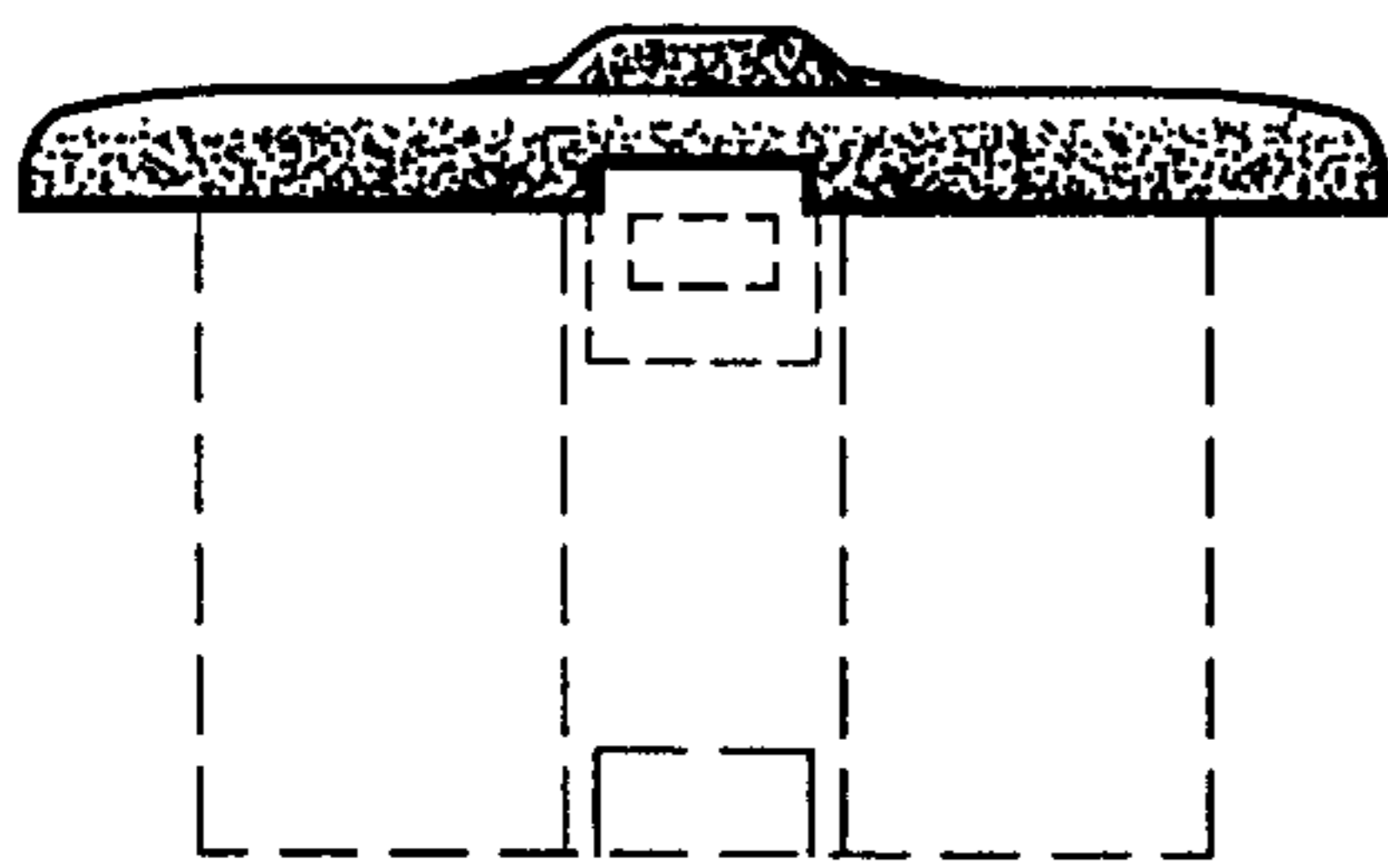

FIG. 9

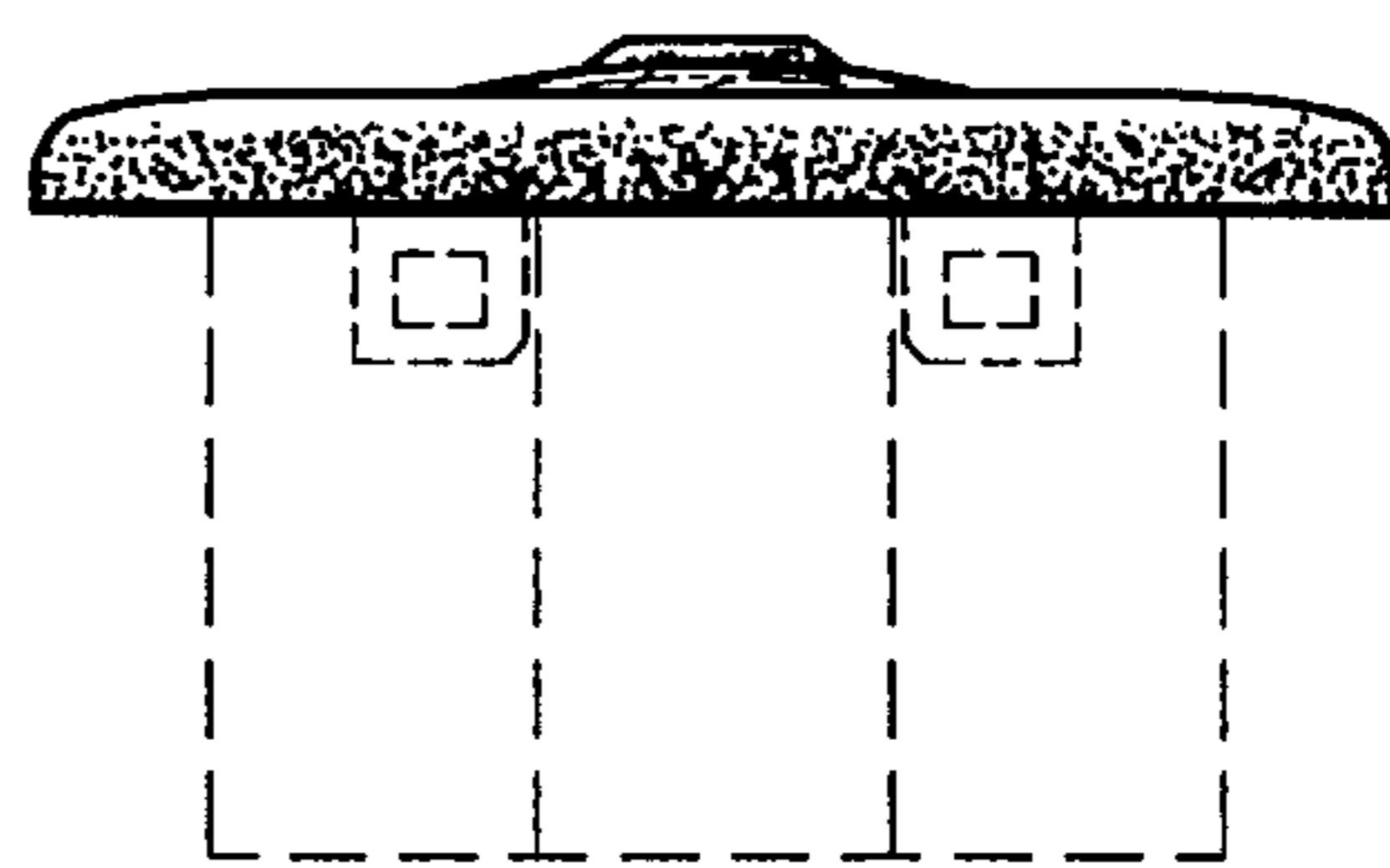

FIG. 10

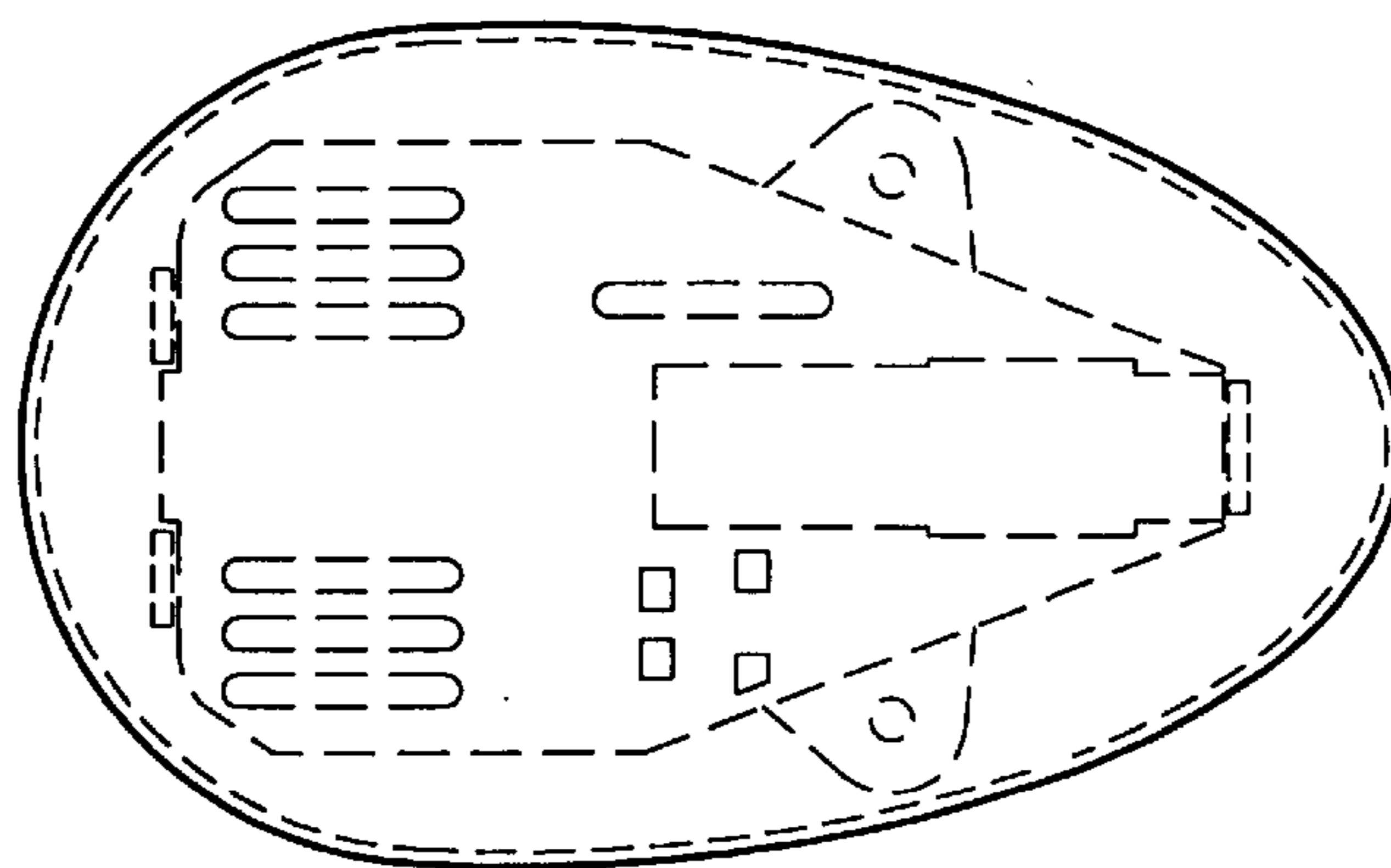

FIG. 11