



US00D425024S

United States Patent [19]

[11] Patent Number: **Des. 425,024**

Klaus et al.

[45] Date of Patent: **** May 16, 2000**

[54] **COMPACT FLUORESCENT BULB SOCKET**

5,757,136 5/1998 Schadhauer 315/56
5,964,518 10/1999 Shen 362/225

[75] Inventors: **Dale A. Klaus**, St. Albans; **Wendell Dodson**, Webster Groves; **Swee Tan**, St. Louis, all of Mo.

Primary Examiner—Joel Sincavage
Attorney, Agent, or Firm—Polster, Lieder, Woodruff & Lucchesi

[73] Assignee: **Dal Partnership**, St. Louis, Mo.

[57] **CLAIM**

[**] Term: **14 Years**

The ornamental design for compact fluorescent bulb socket, as shown and described.

[21] Appl. No.: **29/093,438**

DESCRIPTION

[22] Filed: **Sep. 10, 1998**

[51] **LOC (7) Cl.** **13-03**

[52] **U.S. Cl.** **D13/134**

[58] **Field of Search** D13/134; D26/2, D26/3; 313/318.01, 318.05, 318.09, 323, 324; 439/226, 232, 242, 243; 362/260, 221, 263, 217; 315/56, 58

FIG. 1 is an exploded perspective view of the compact fluorescent bulb socket of the present invention with a securing ring separate from a body of the socket;

FIG. 2 is a perspective view of the compact fluorescent bulb socket with the securing ring threaded onto the socket body; FIG. 3 is an exploded side elevational view of the socket; FIG. 4 is an exploded side elevational view of the socket rotated 90° from FIG. 3;

FIG. 5 is a side elevational view of the compact fluorescent bulb socket with the securing ring threaded onto the socket body, all side elevational views of the assembled socket being identical;

FIG. 6 is a top plan view of the compact fluorescent bulb socket; and,

FIG. 7 is a bottom plan view of the fluorescent bulb socket. The broken line showing in FIGS. 1, 2, 6 and 7 is included for the purpose of illustrating environmental structure only and forms no part of the claimed design.

[56] References Cited

U.S. PATENT DOCUMENTS

D. 291,557	8/1987	Engel	D13/135
D. 348,249	6/1994	Hester	D13/134
D. 415,103	10/1999	Klaus et al.	D13/134
D. 415,104	10/1999	Klaus et al.	D13/134
4,080,030	3/1978	Ustin	439/230
4,683,402	7/1987	Aubrey	315/56
4,723,200	2/1988	Troen	362/260
4,902,932	2/1990	Yang	315/71
4,974,131	11/1990	Paradiso	362/217

1 Claim, 2 Drawing Sheets

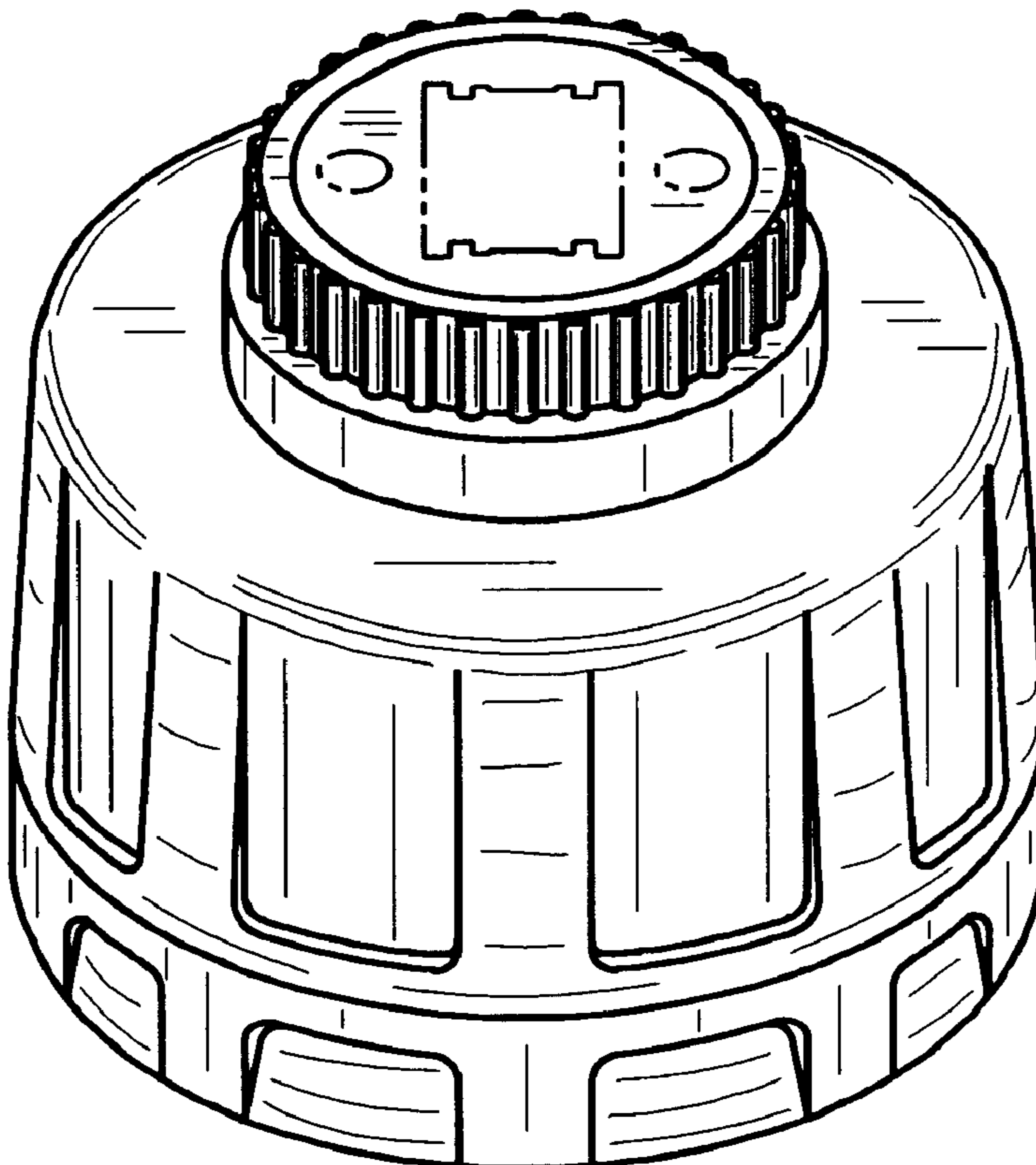

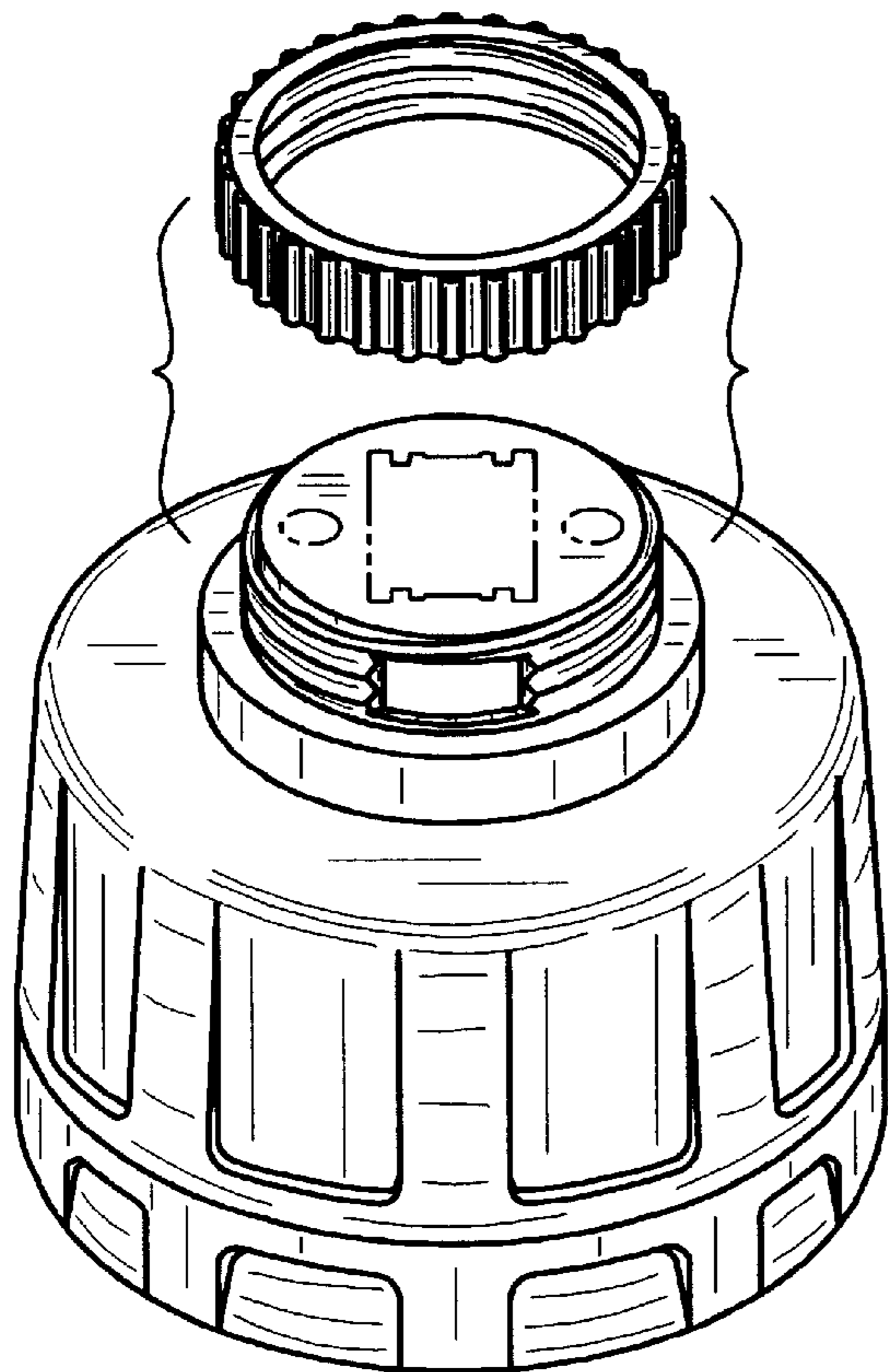

FIG. 1

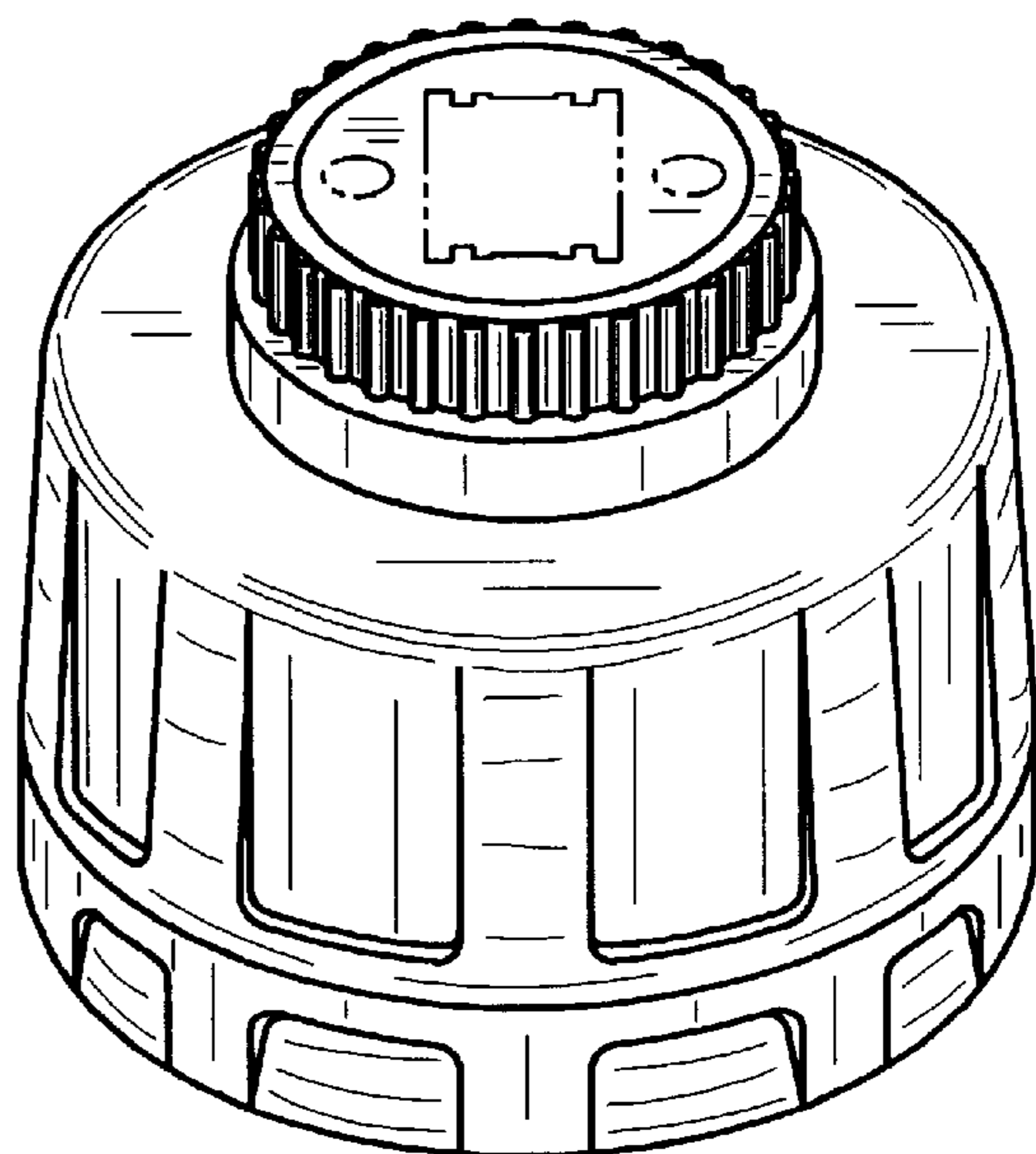

FIG. 2

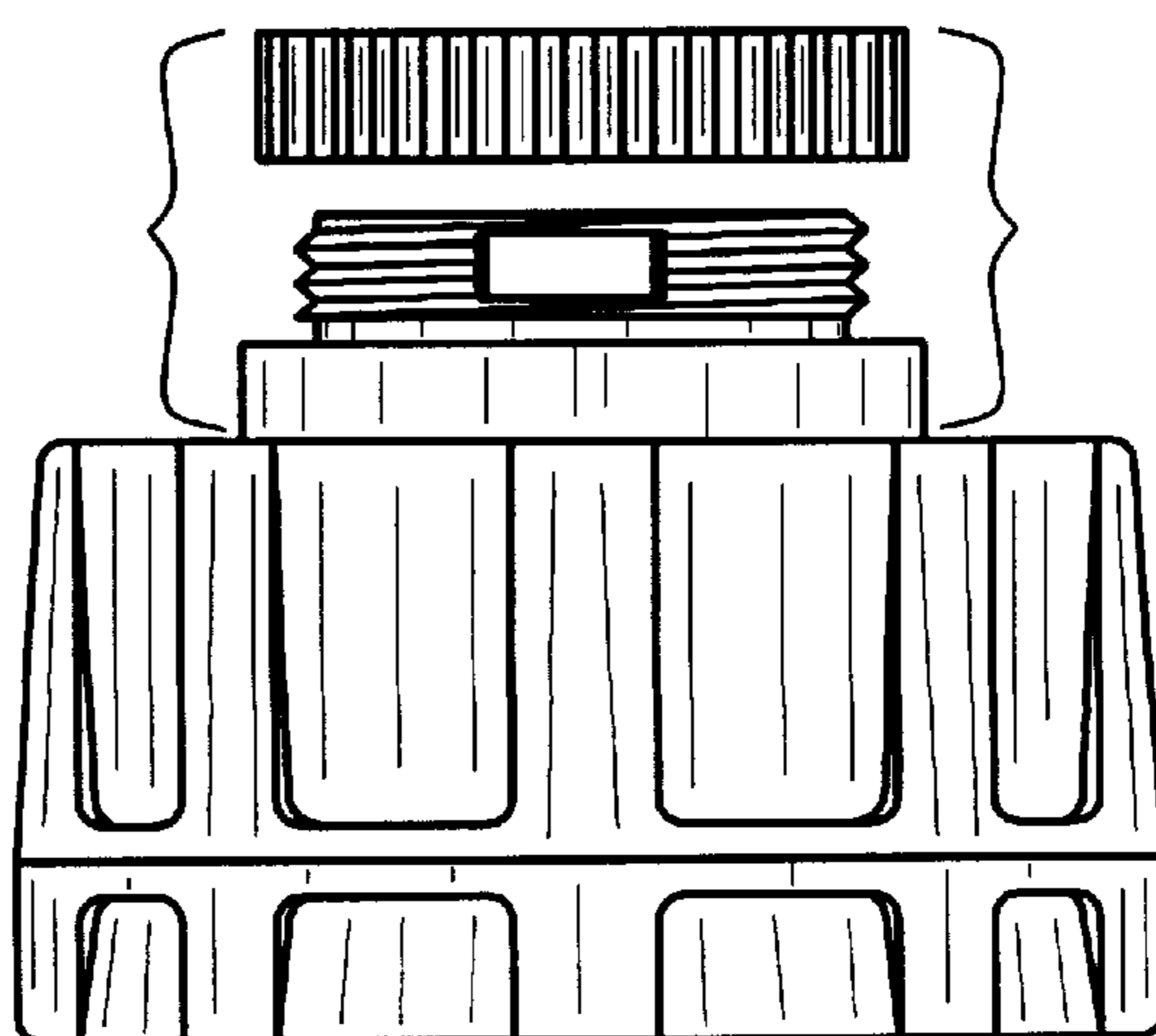

FIG. 3

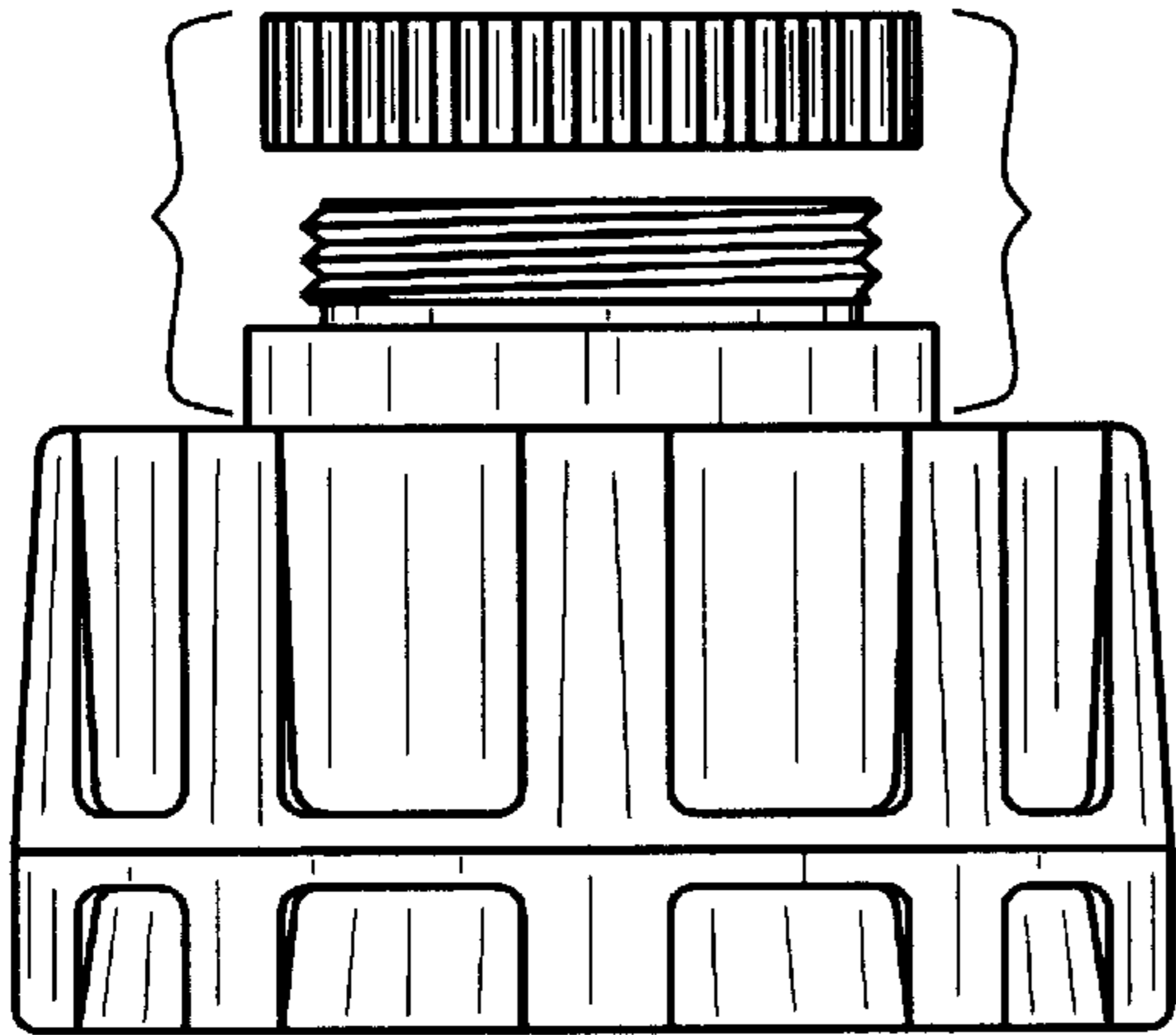

FIG. 4

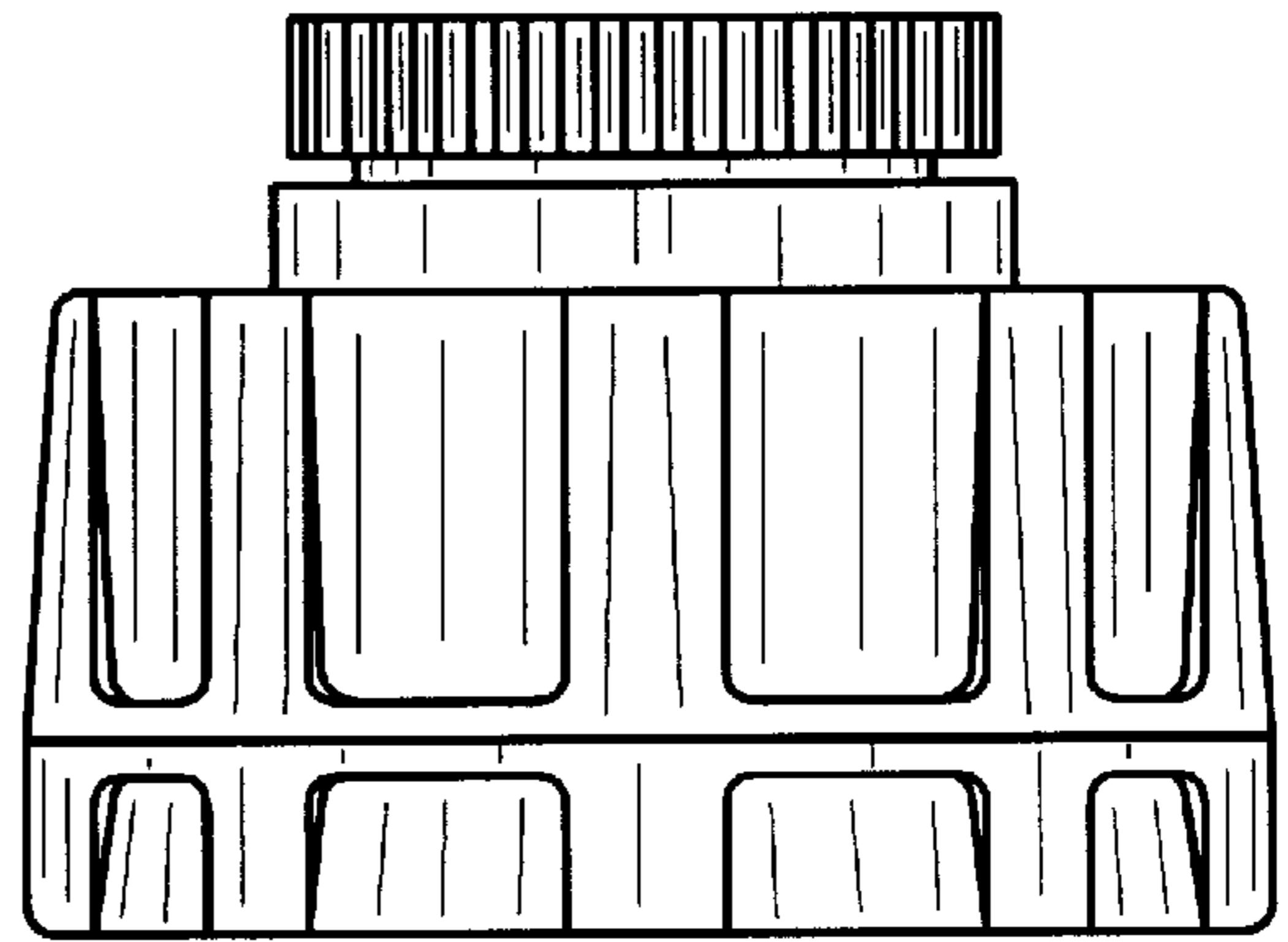

FIG. 5

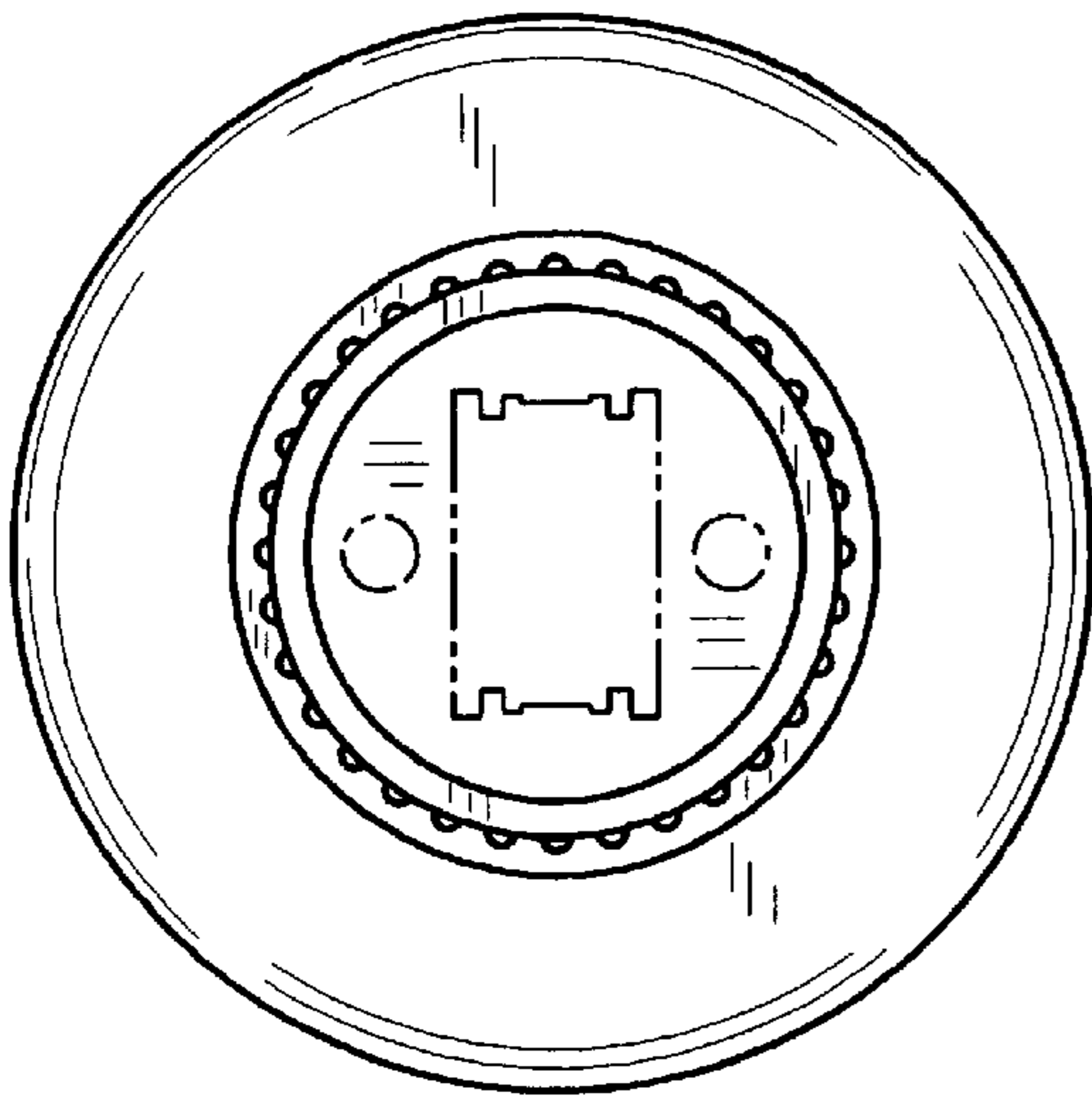

FIG. 6

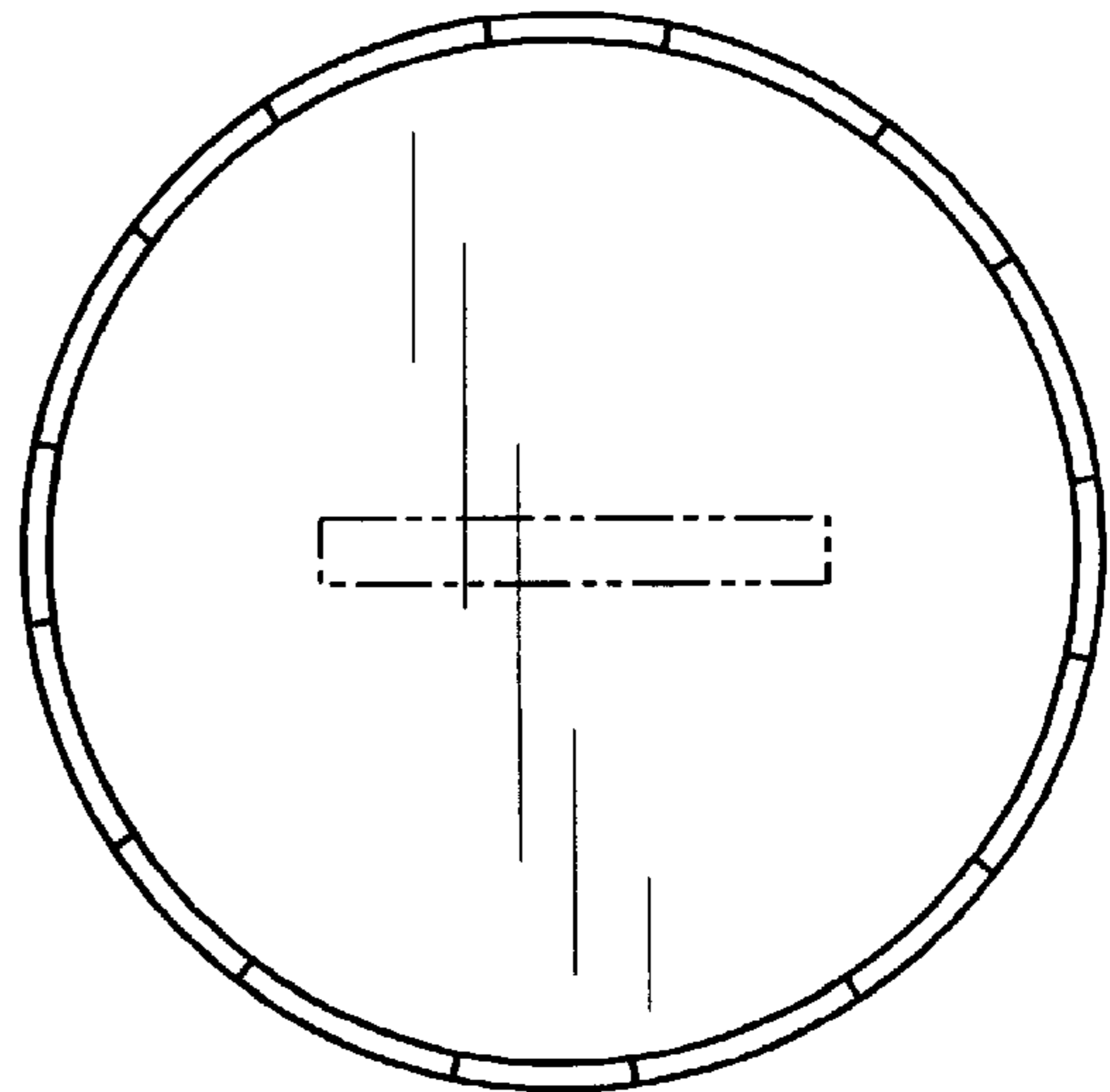

FIG. 7