



US00D425001S

United States Patent [19]
Bullock

[11] **Patent Number: Des. 425,001**

[45] **Date of Patent: ** May 16, 2000**

[54] **TRAILER HITCH ALIGNMENT MIRROR**

[76] Inventor: **Kirk D. T. Bullock**, 5420 Penrith Dr.,
Durham, N.C. 27713

[**] Term: **14 Years**

[21] Appl. No.: **29/107,156**

[22] Filed: **Jun. 29, 1999**

[51] **LOC (7) Cl.** **12-16**

[52] **U.S. Cl.** **D12/188**

[58] **Field of Search** D12/187-189;
359/838, 843, 844, 850, 868, 871, 872,
874, 876, 877, 881, 841; 248/475.1, 480,
481, 479, 487, 494, 483

[56] **References Cited**

U.S. PATENT DOCUMENTS

D. 329,631	9/1992	Cameron	D12/187
D. 344,485	2/1994	Linne et al.	D12/187
3,698,798	10/1972	Bolton	359/881
5,309,289	5/1994	Johnson	359/871
5,576,900	11/1996	Baumler et al.	359/872

OTHER PUBLICATIONS

Northern Tool & Equipment Co. Catalogue—p. 143 depicting
“Hitch Align” Portable Mirror 1997.

Primary Examiner—Ralf Seifert
Attorney, Agent, or Firm—Olive & Olive, P.A.

[57] **CLAIM**

The ornamental design for a trailer hitch alignment mirror,
as shown and described.

DESCRIPTION

FIG. 1 is a front elevation view of a trailer hitch alignment
mirror showing a first embodiment of my new design.

FIG. 2 is a rear elevation view thereof.

FIG. 3 is a left side elevation view thereof, the right side
being a mirror image thereof.

FIG. 4 is a top plan view thereof.

FIG. 5 is a bottom plan view thereof.

FIG. 6 is a front elevation view of a trailer hitch alignment
mirror showing a second embodiment of my new design.

FIG. 7 is a rear elevation view thereof.

FIG. 8 is a top plan view thereof.

FIG. 9 is a bottom plan view thereof.

FIG. 10 is a right side elevation view thereof, the left side
being a mirror image thereof.

FIG. 11 is a right side elevation view of the first embodiment
of the trailer hitch alignment mirror as it is mounted on a
trailer tongue for use in providing to the vehicle operator a
view of the trailer hitch coupling process; and,

FIG. 12 is a right side elevation view of the second embodi-
ment of the trailer hitch alignment mirror as it is mounted on
a towing vehicle for use in providing to the vehicle operator
a view of the trailer hitch coupling process.

1 Claim, 7 Drawing Sheets

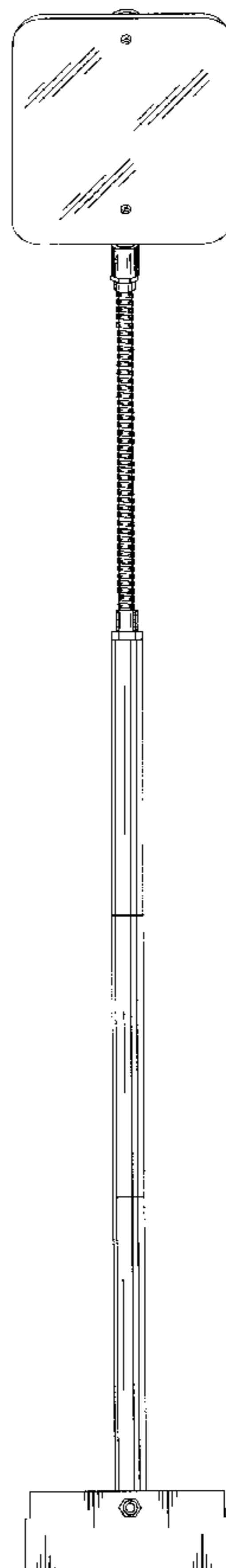

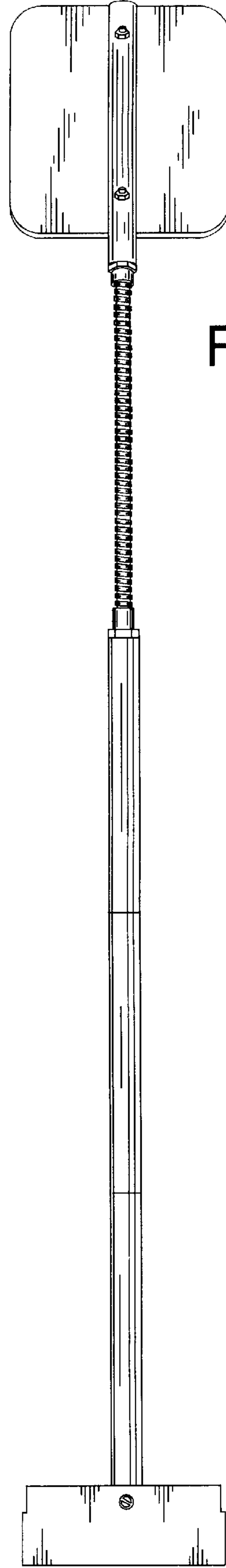
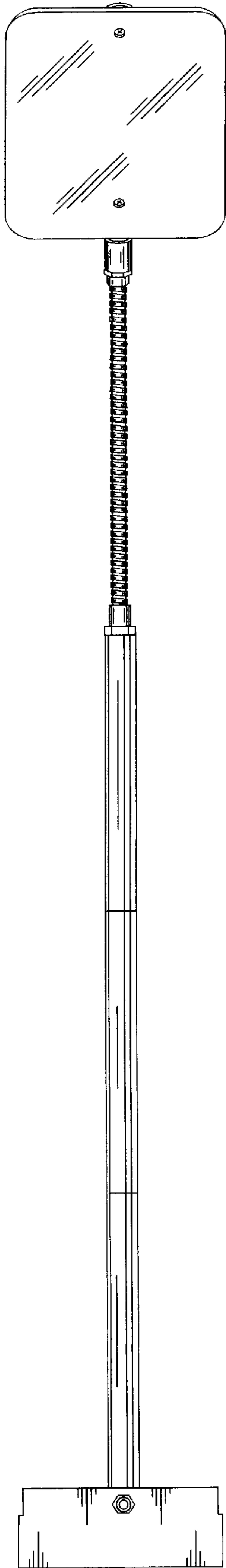

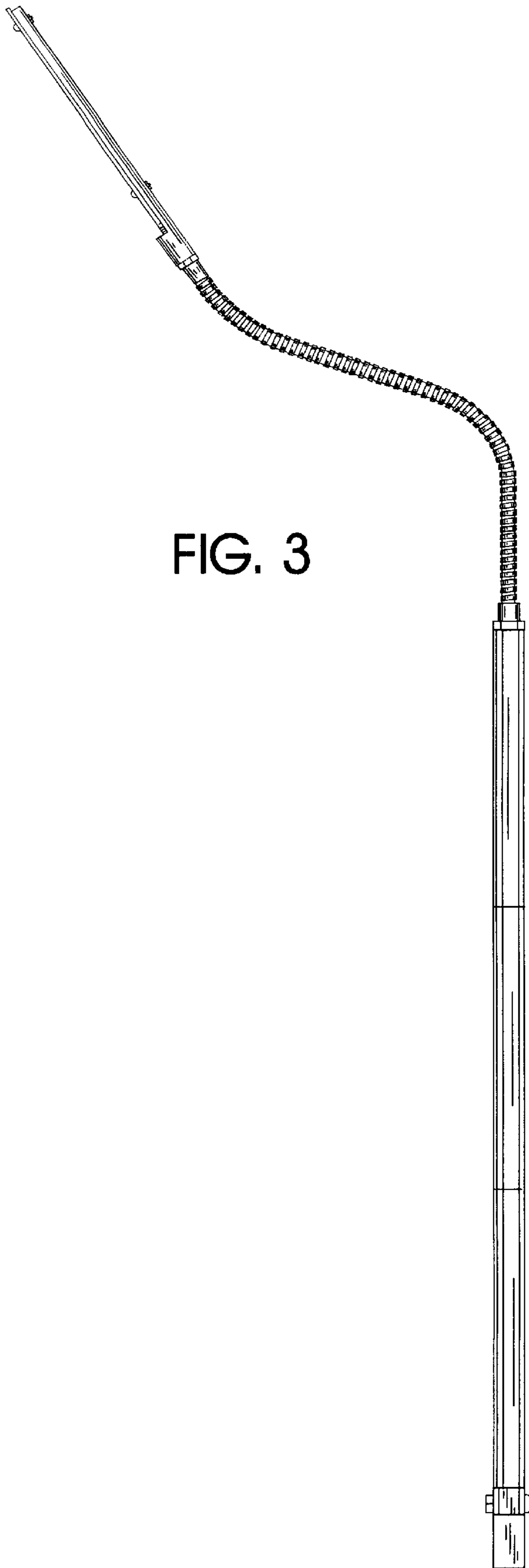

FIG. 3

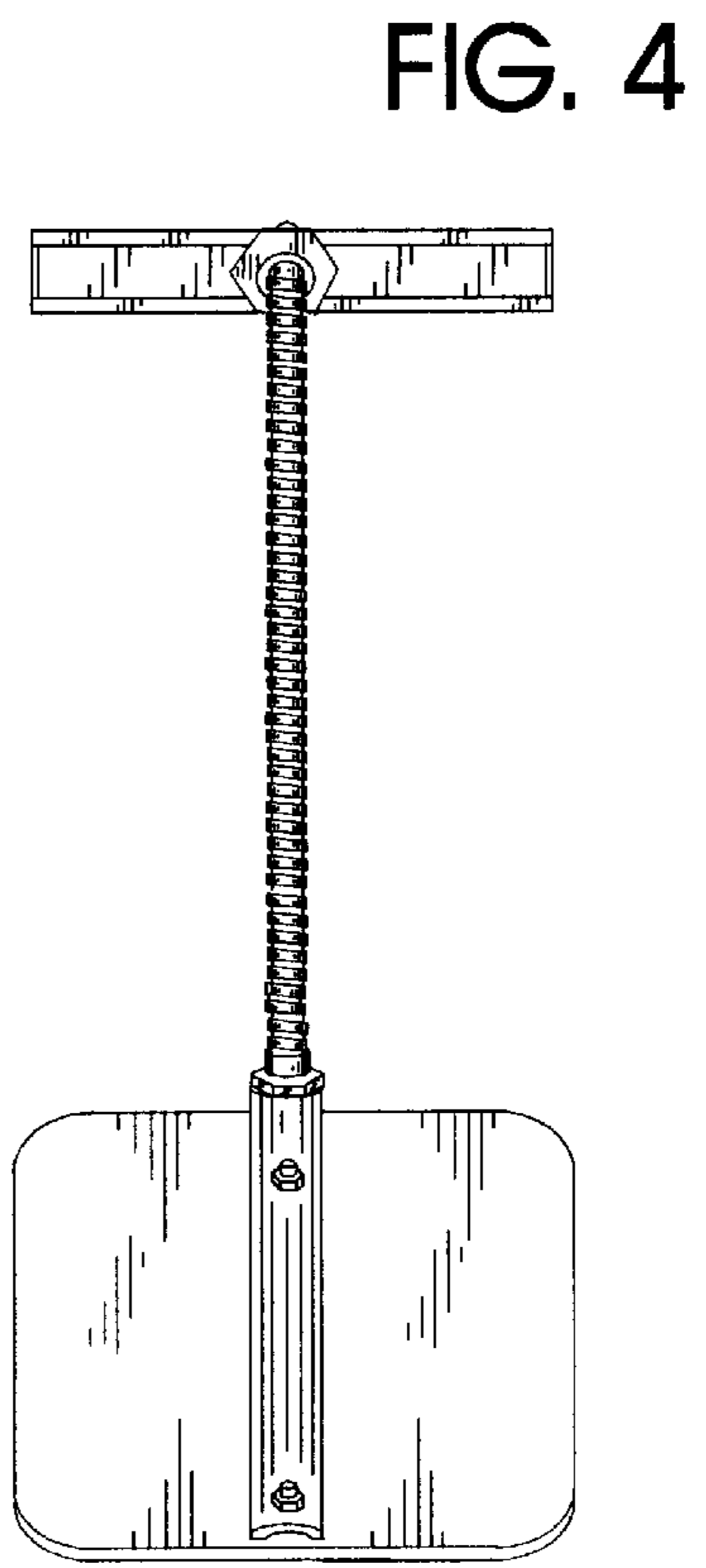

FIG. 4

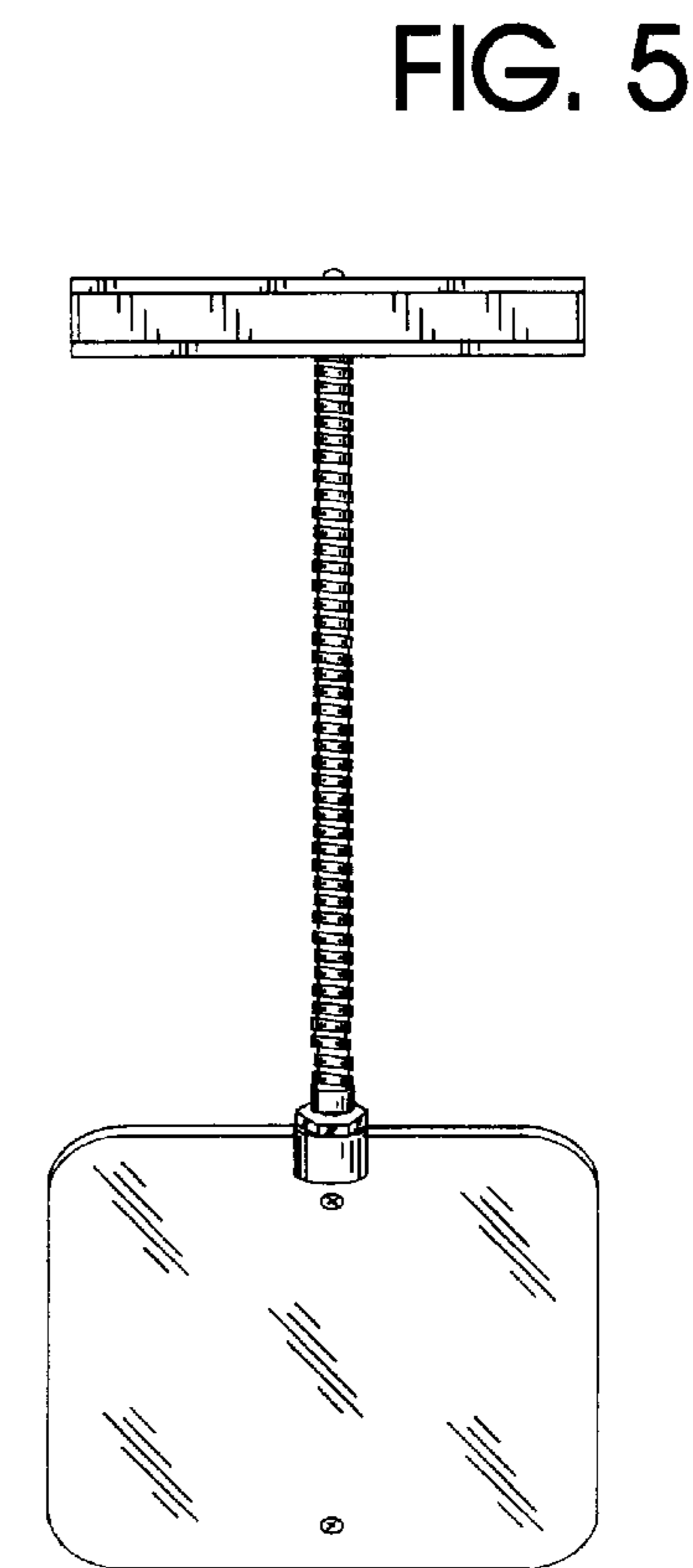

FIG. 5

FIG. 6

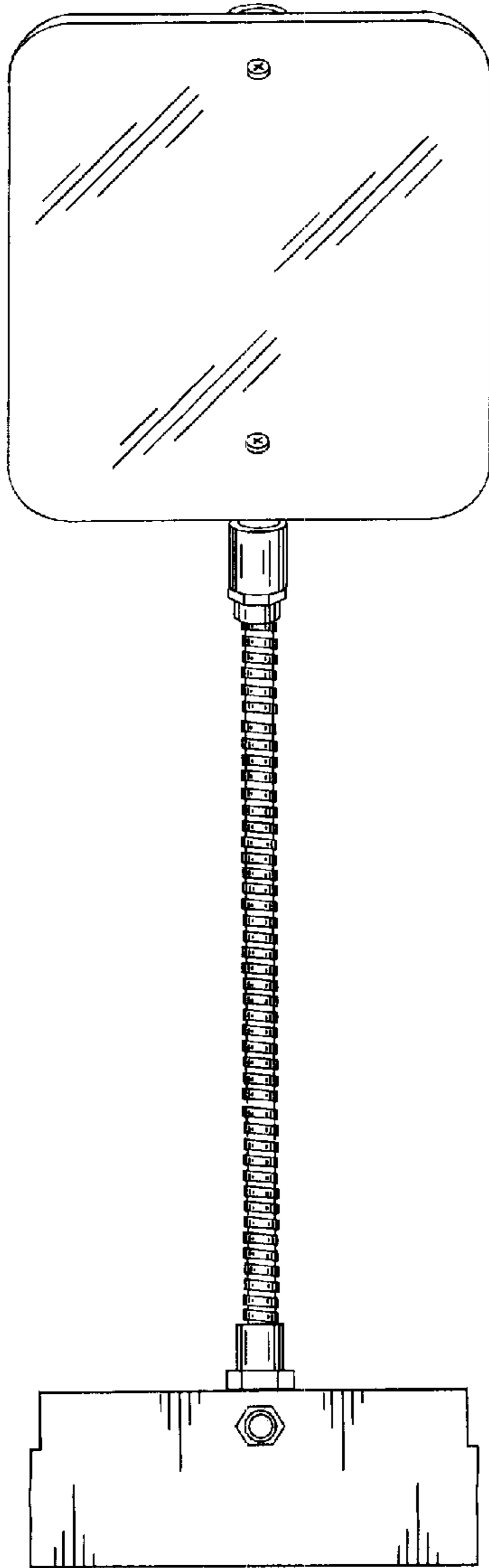

FIG. 7

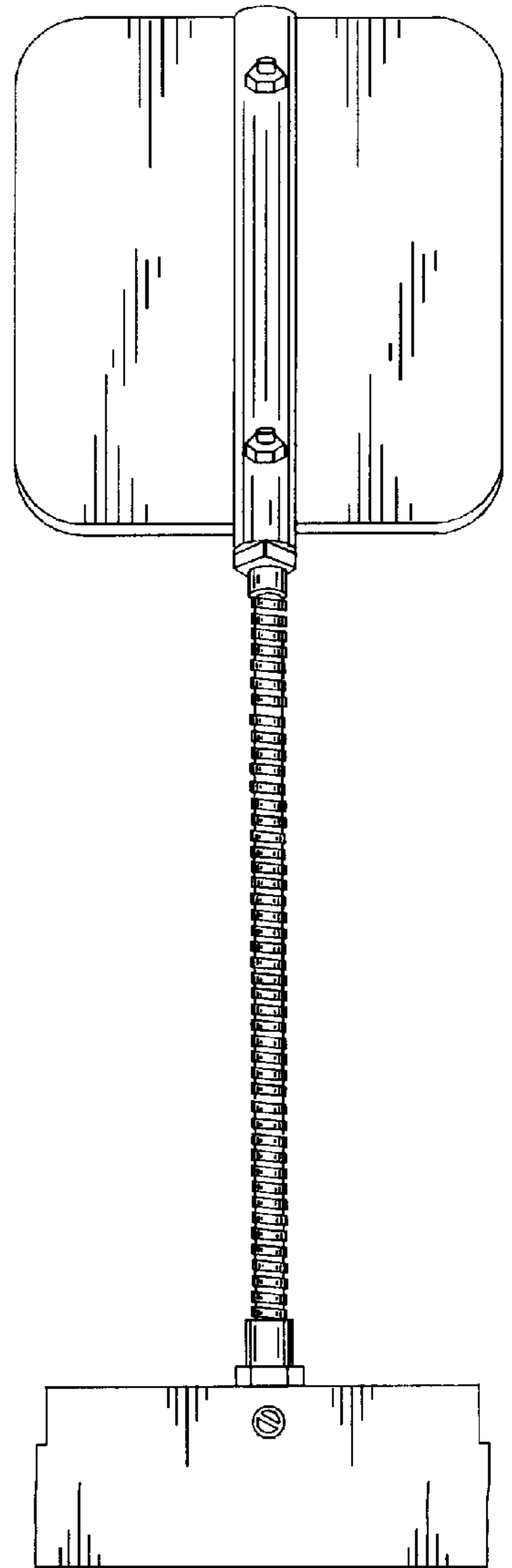

FIG. 8

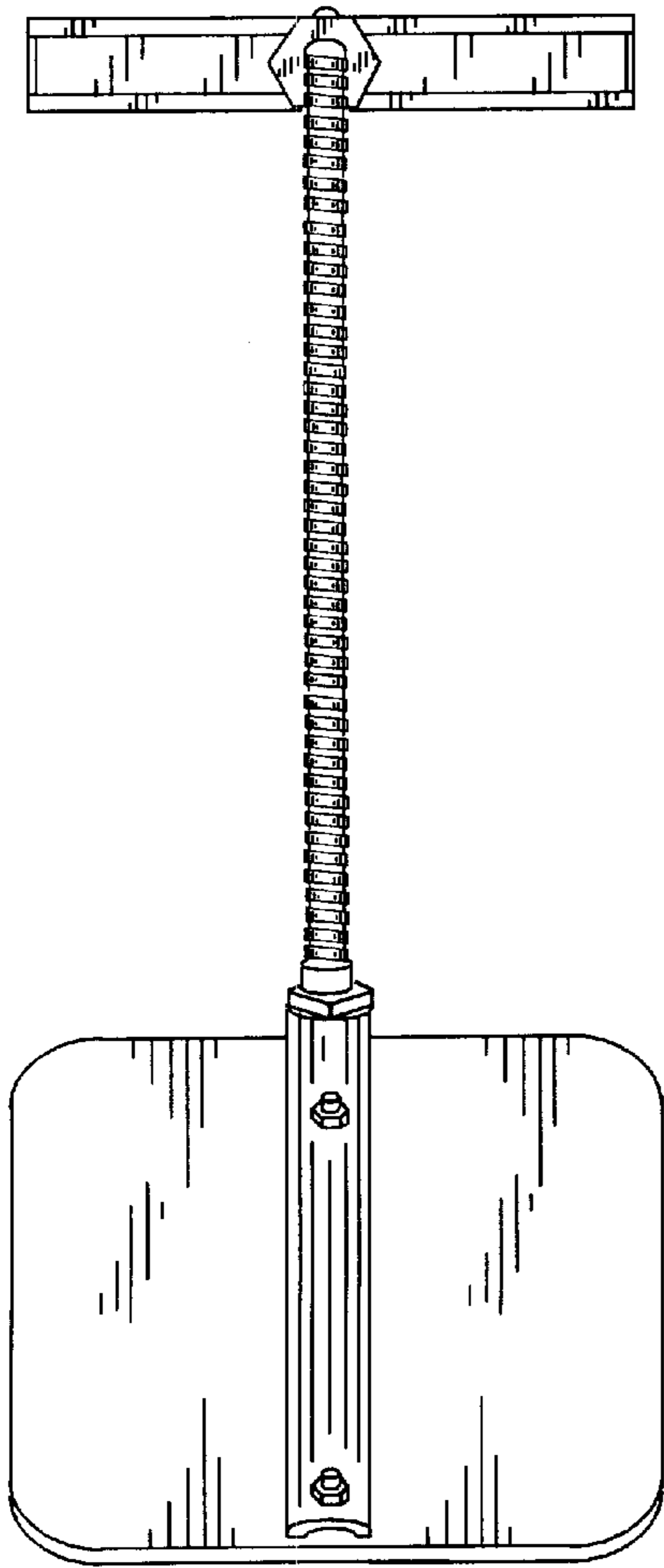

FIG. 9

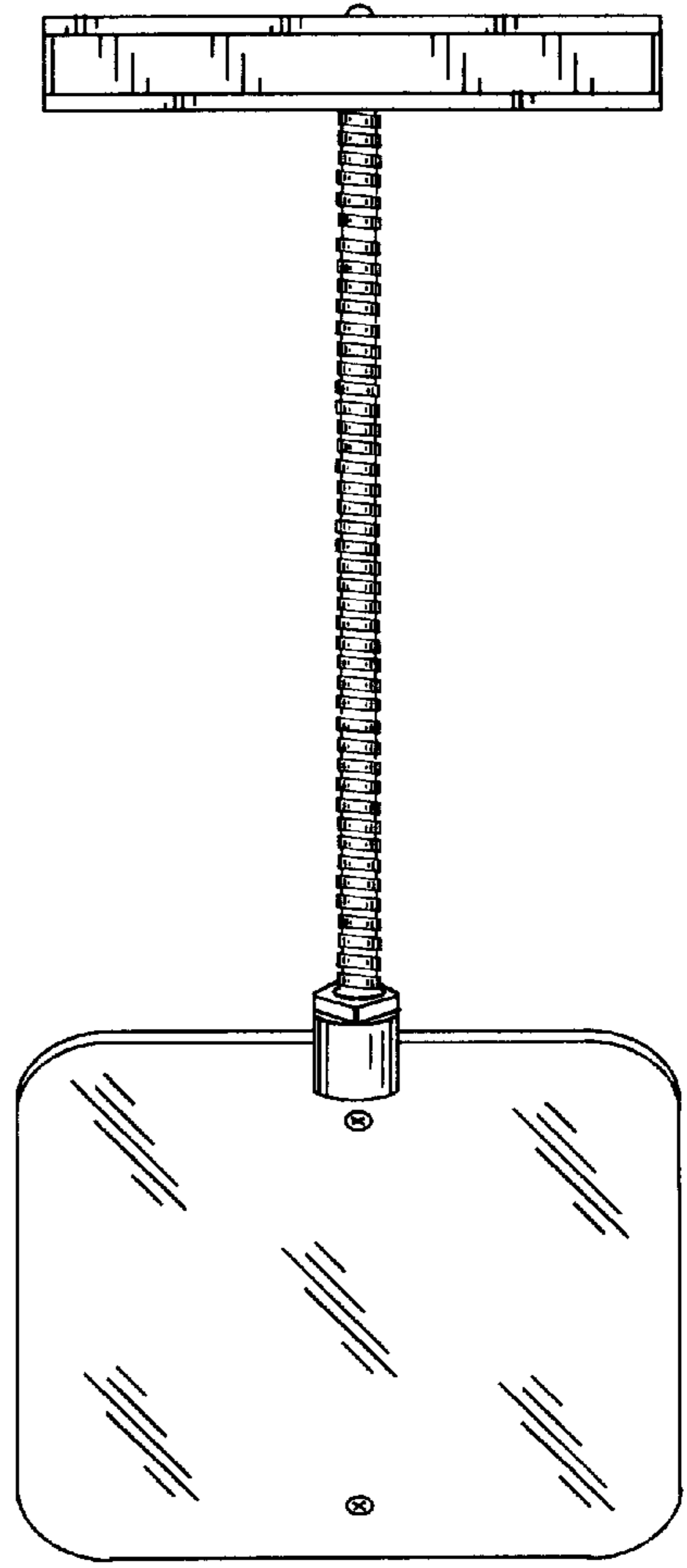
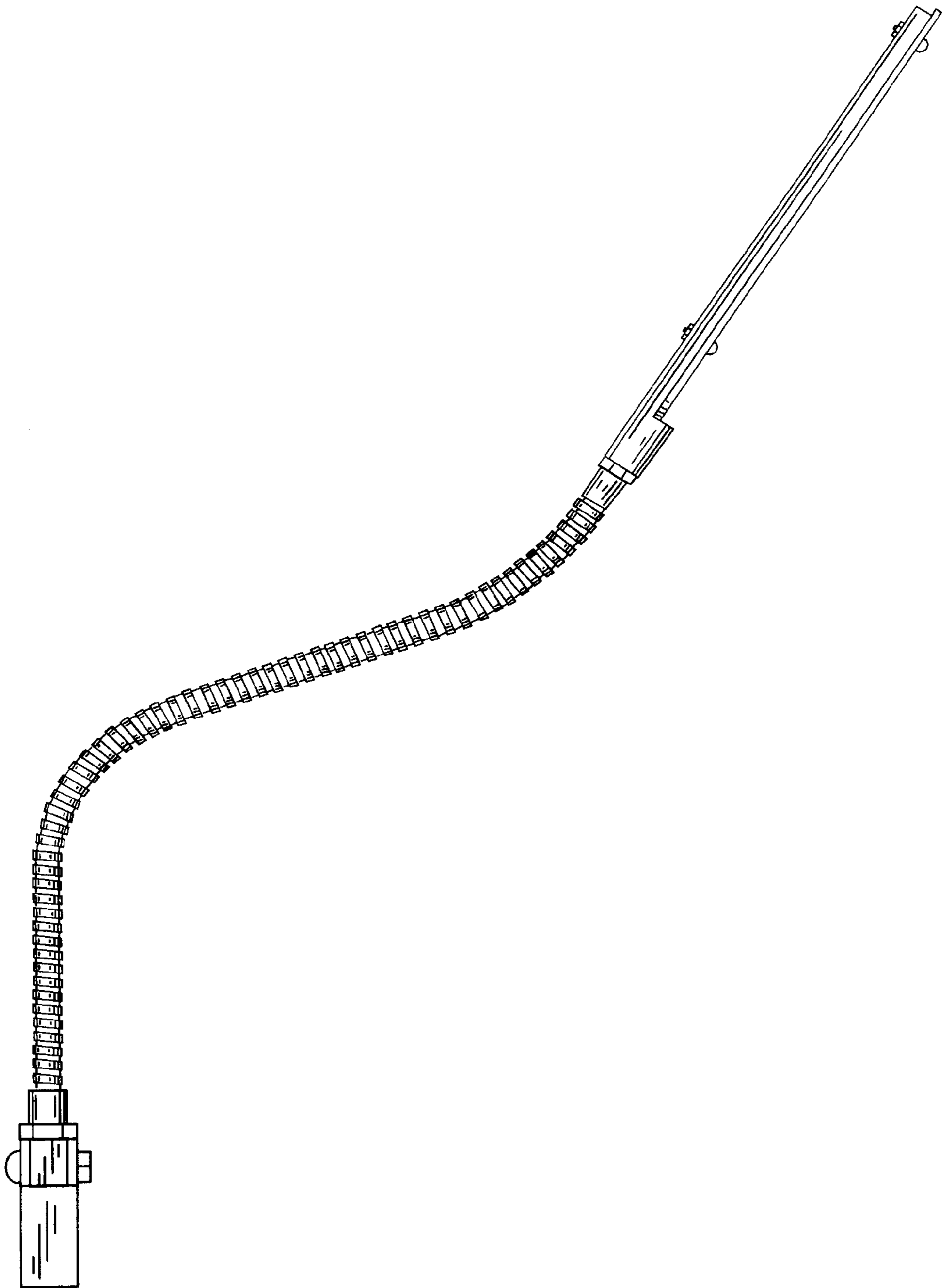

FIG. 10



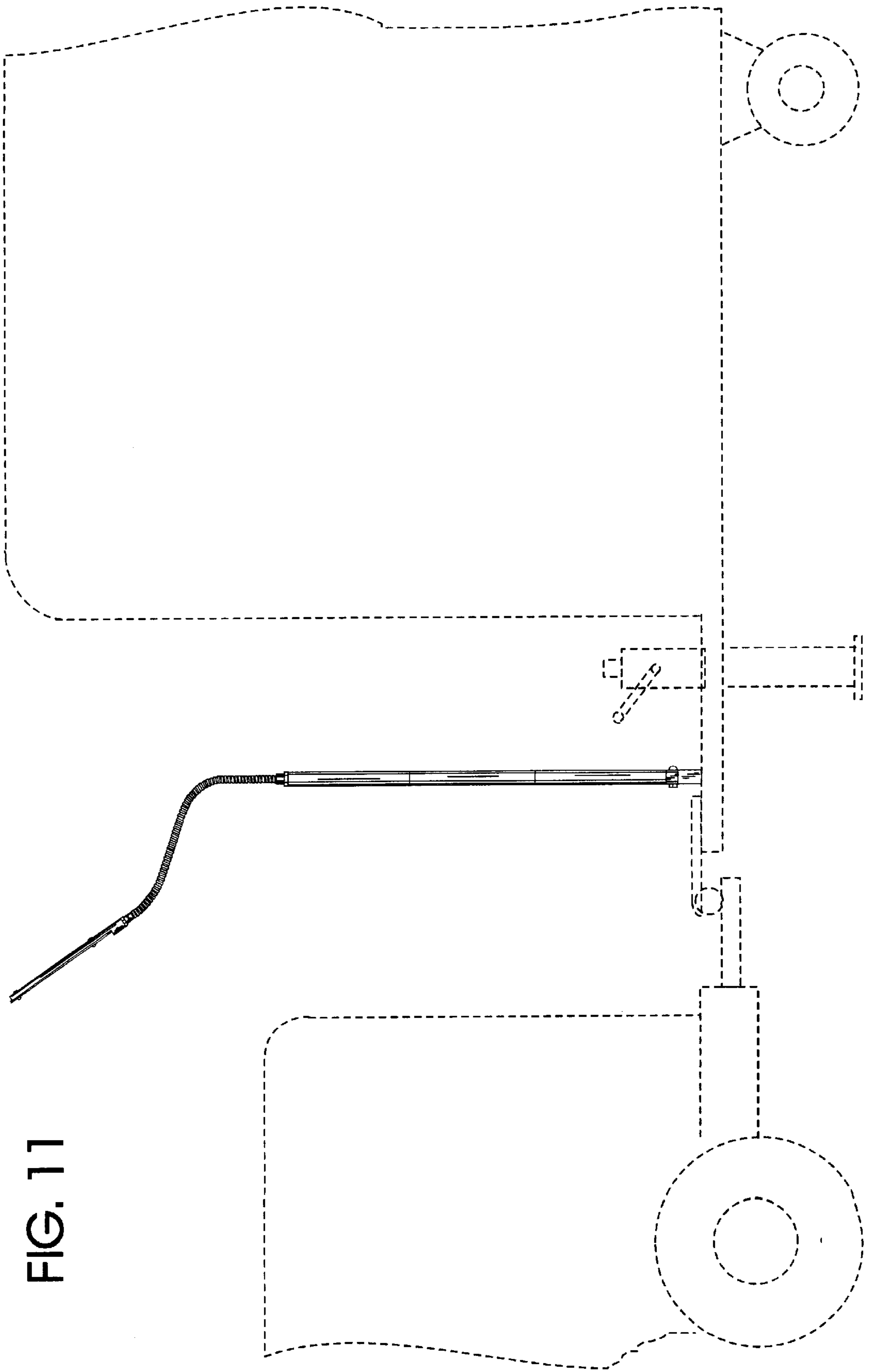

FIG. 11

FIG. 12

