



US00D424979S

United States Patent [19]

[11] **Patent Number: Des. 424,979**

Hanagan et al.

[45] **Date of Patent: ** May 16, 2000**

[54] **PERSONAL VEHICLE**

5,305,845	4/1994	Van Dooren	180/65.1
5,343,974	9/1994	Robek	180/216
5,460,234	10/1995	Matscura et al.	180/65.1

[75] Inventors: **Michael W. Hanagan**, Monterey;
Donald D. Varner, Hollister, both of Calif.

Primary Examiner—Melody N. Brown
Attorney, Agent, or Firm—Pepe & Hazard LLP

[73] Assignee: **Corbin Pacific, Inc.**, Hollister, Calif.

[57] **CLAIM**

[**] Term: **14 Years**

The ornamental design for a personal vehicle, as shown.

[21] Appl. No.: **29/093,634**

DESCRIPTION

[22] Filed: **Sep. 15, 1998**

[51] **LOC (7) Cl.** **12-08**

[52] **U.S. Cl.** **D12/85**

[58] **Field of Search** D12/85, 86; 296/185;
180/65.1

FIG. 1 is a perspective view of a personal vehicle showing our new design with the windshield wiper and bumper illustrated in phantom line;

FIG. 2 is a right side elevational view thereof;

FIG. 3 is a left side elevational view thereof;

FIG. 4 is a top plan view thereof;

FIG. 5 is a front elevational view thereof;

FIG. 6 is a rear elevational view thereof;

FIG. 7 is a perspective view of another personal vehicle showing a second embodiment of our new design with the windshield wiper and bumper illustrated in phantom line;

FIG. 8 is a right side elevational view of FIG. 7;

FIG. 9 is a left side elevational view of FIG. 7;

FIG. 10 is a top plan of FIG. 7;

FIG. 11 is a front elevational view of FIG. 7; and,

FIG. 12 is a rear elevational view of FIG. 7.

[56] **References Cited**

U.S. PATENT DOCUMENTS

D. 287,477	12/1986	Takasu	D12/85
D. 320,958	10/1991	Kimura et al.	D12/85
D. 329,211	9/1992	Malewicki	D12/85
D. 404,688	1/1999	Hanogan et al.	D12/85
4,313,517	2/1982	Pivar	180/216
4,453,763	6/1984	Richards	296/185
4,573,546	3/1986	Irimajiri et al.	180/89.1
4,671,563	6/1987	Shakespear	296/185

1 Claim, 12 Drawing Sheets

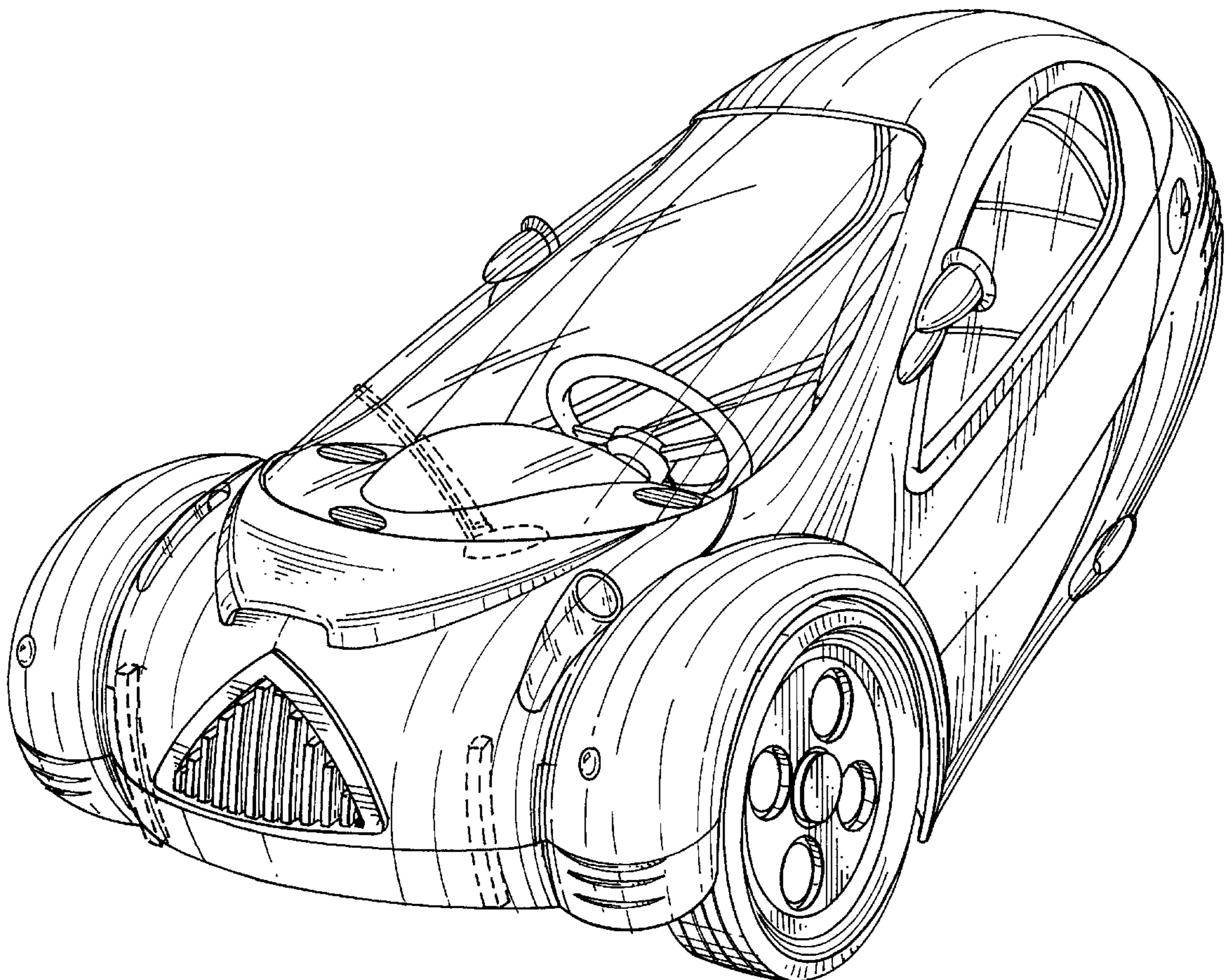

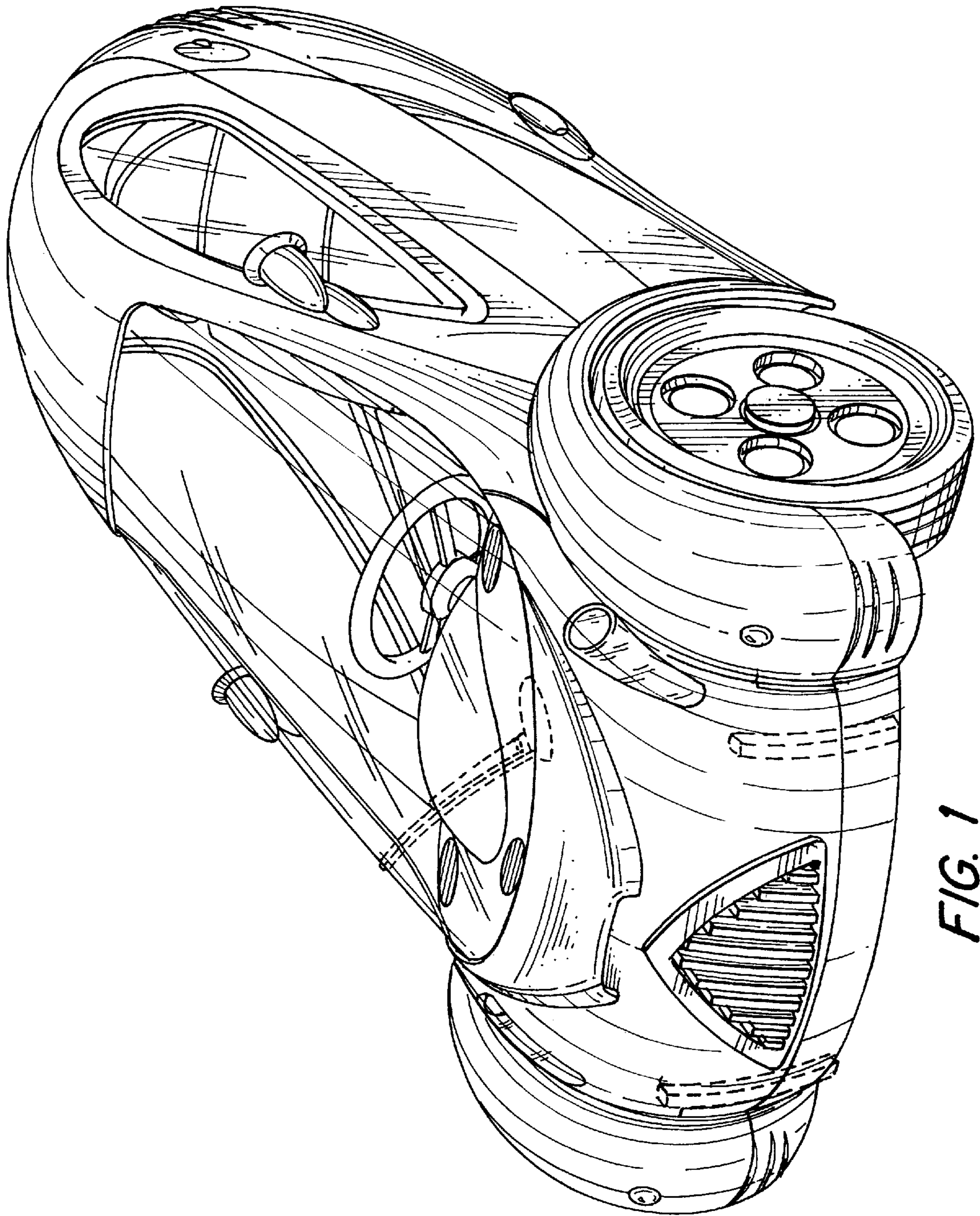

FIG. 1

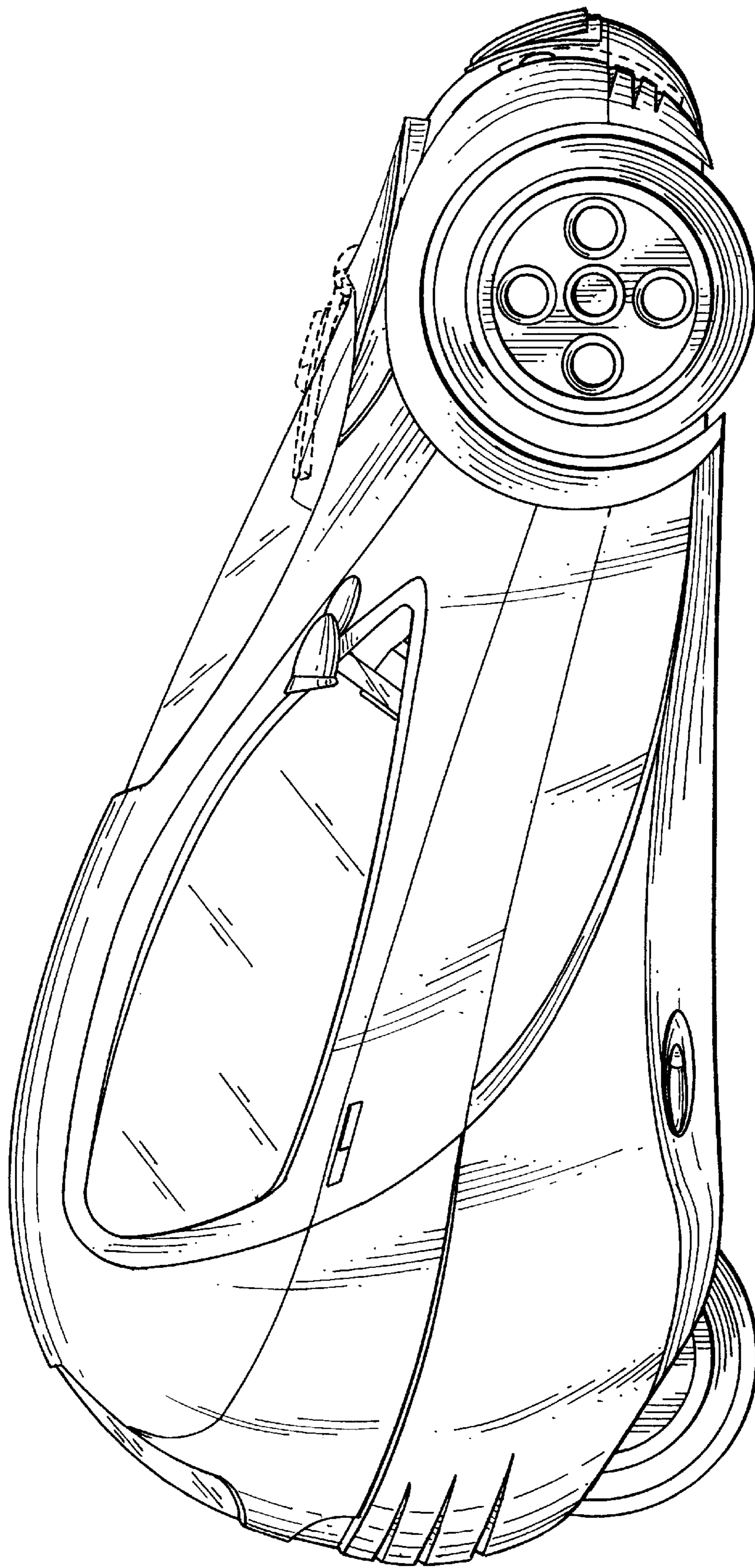

FIG. 2

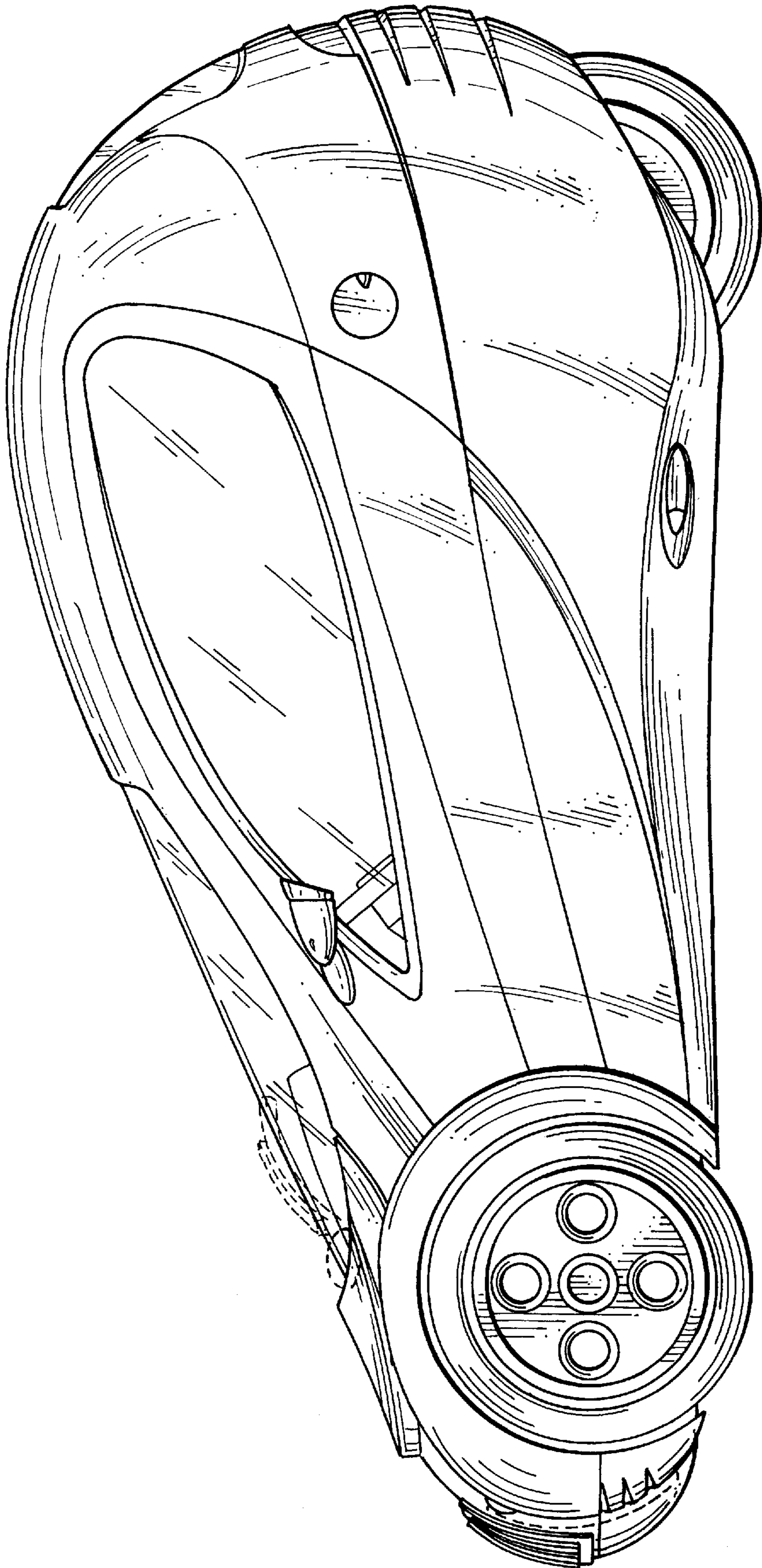

FIG. 3

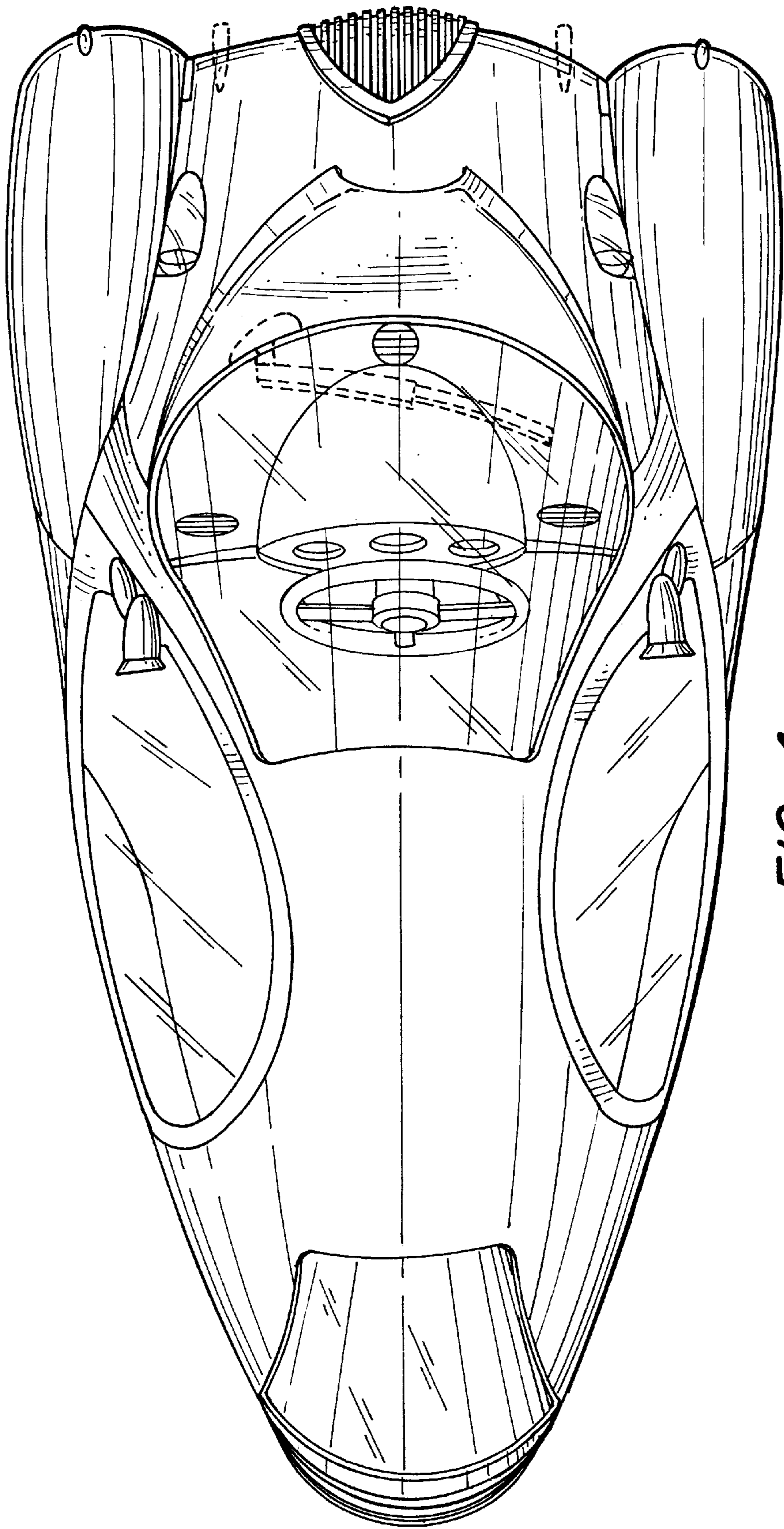

FIG. 4

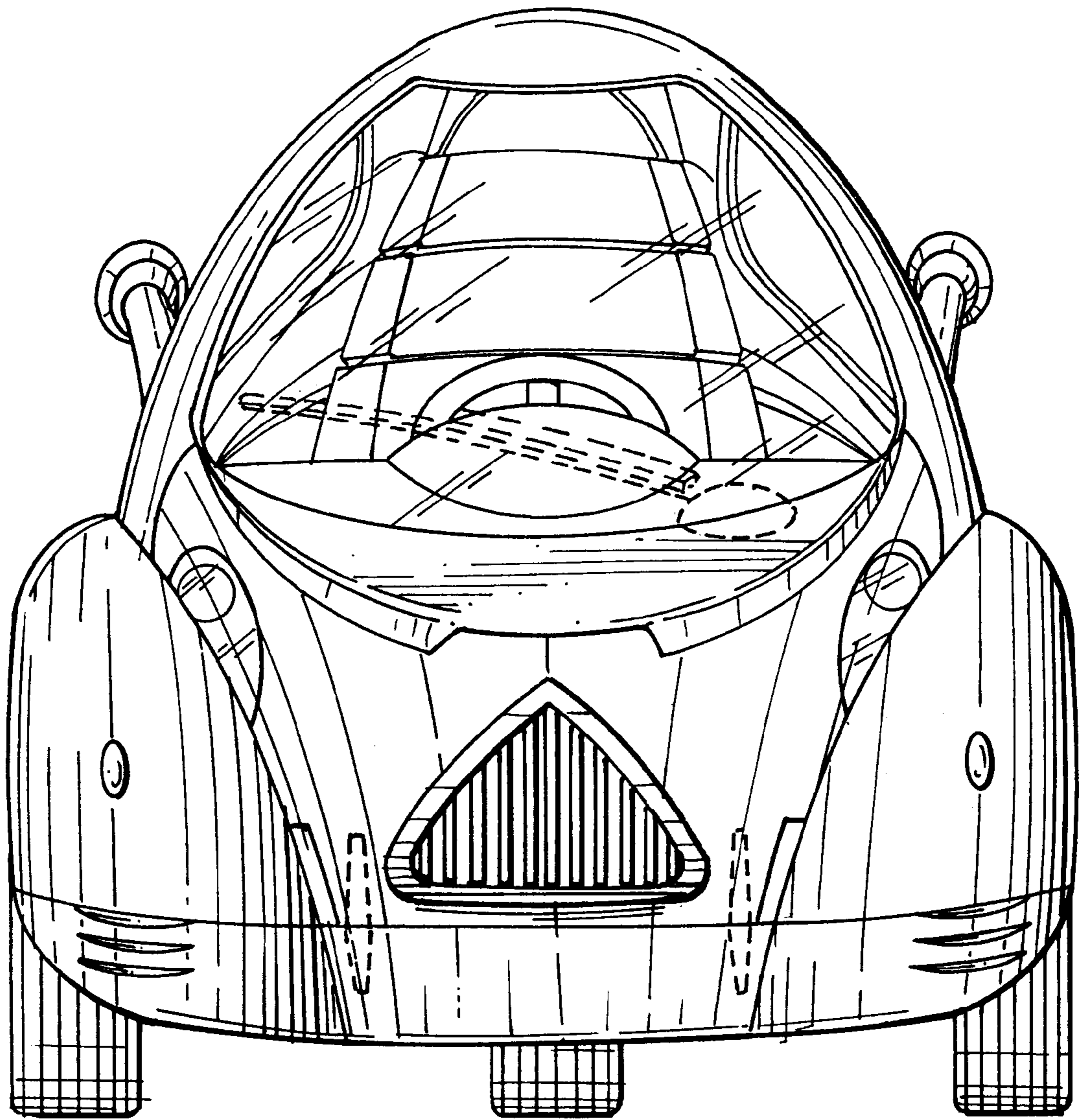

FIG. 5

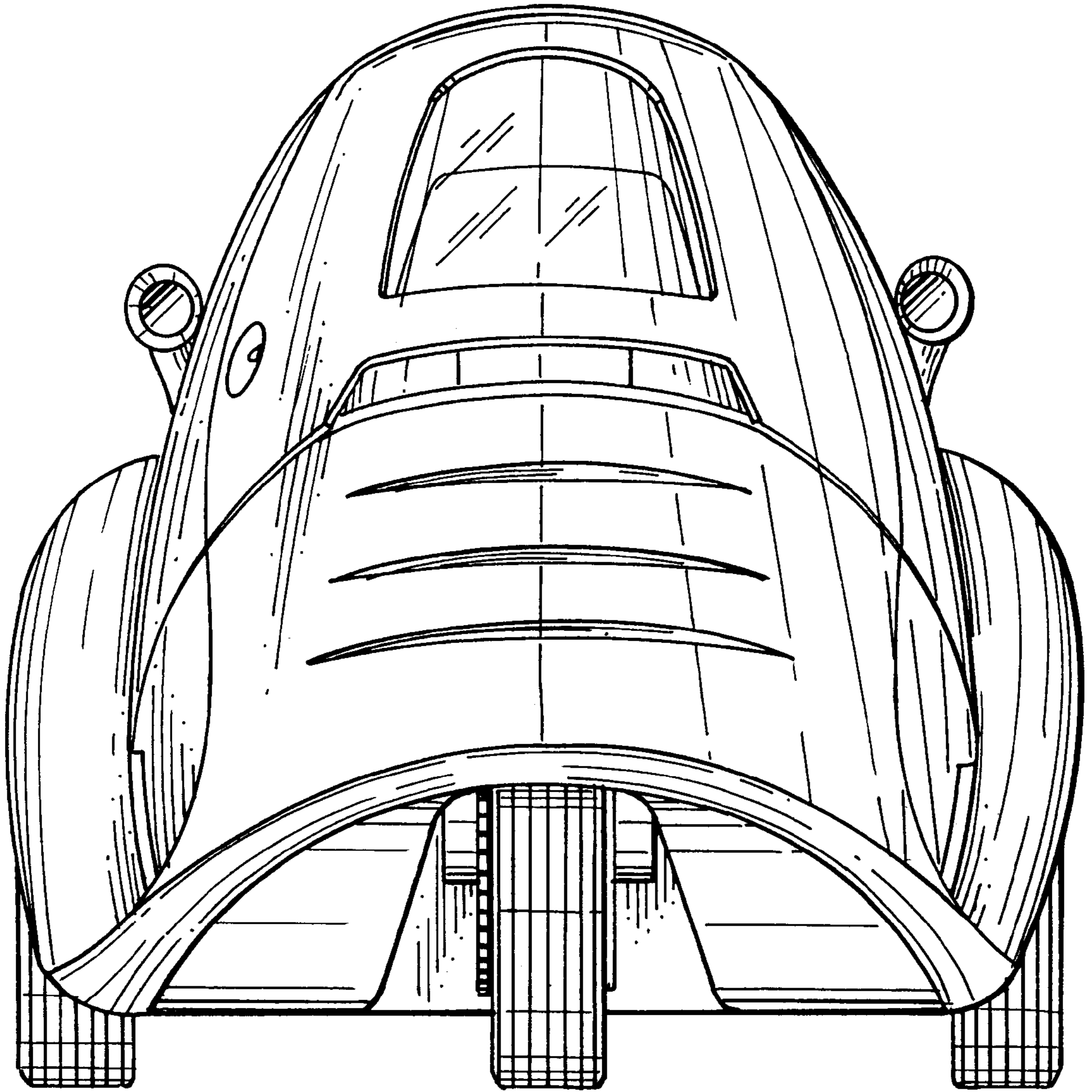

FIG. 6

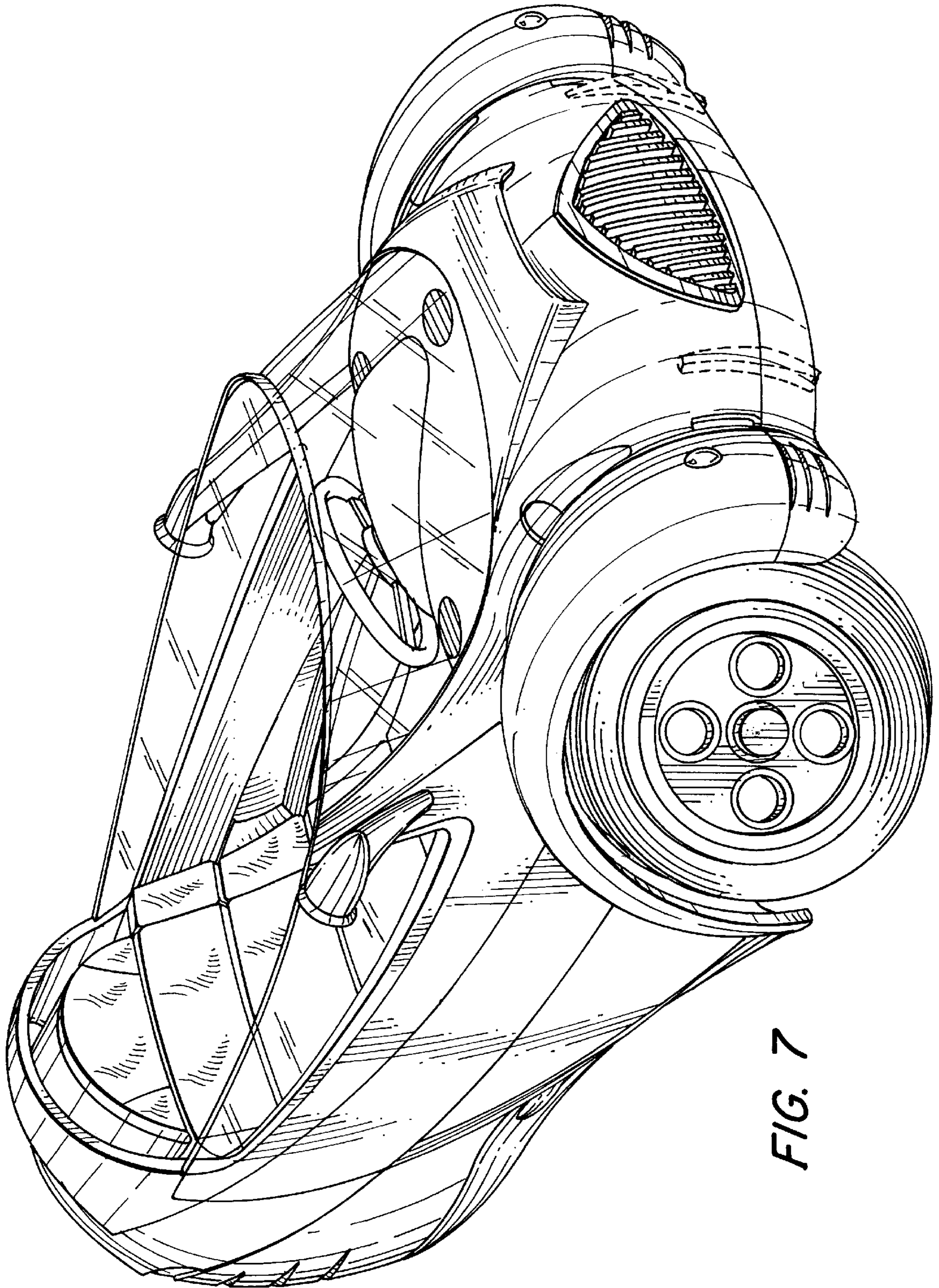

FIG. 7

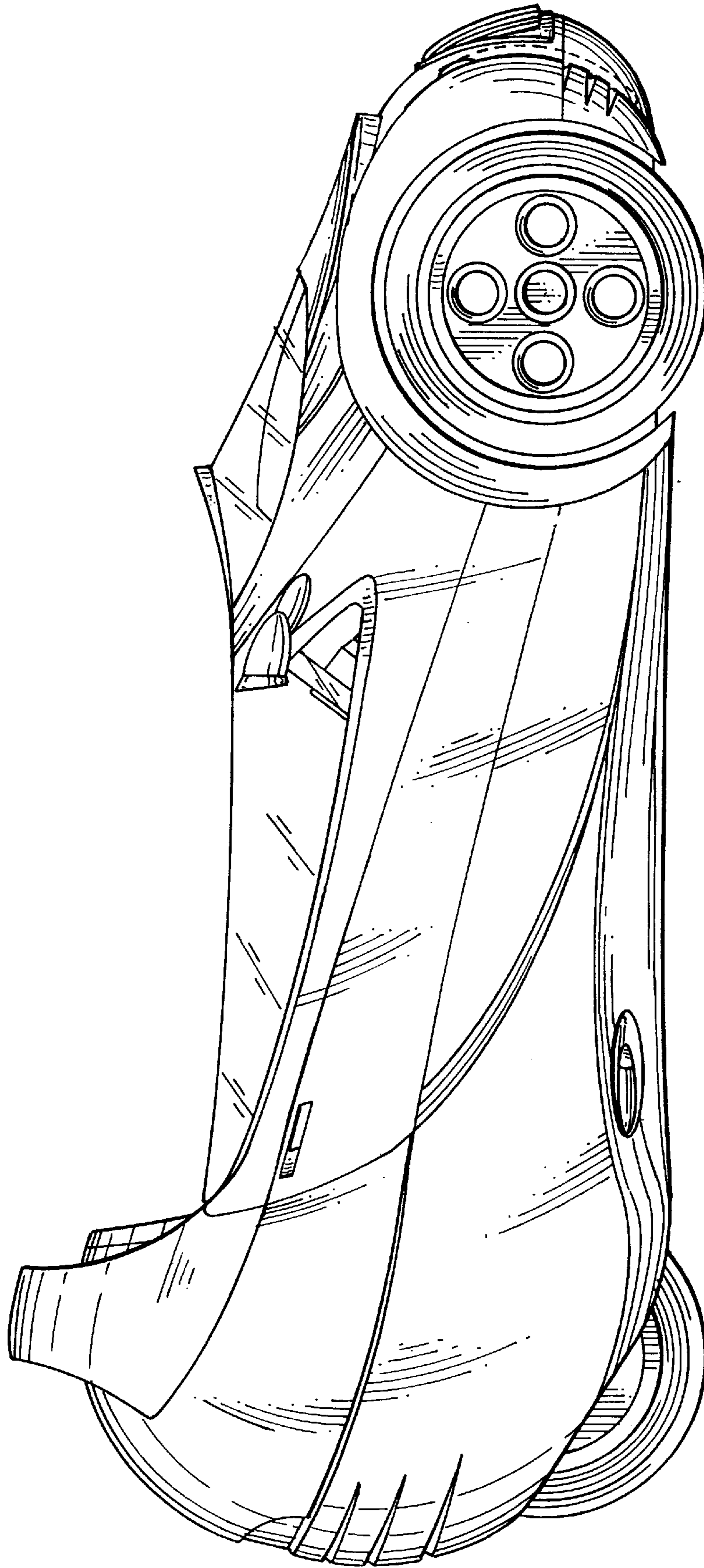

FIG. 8

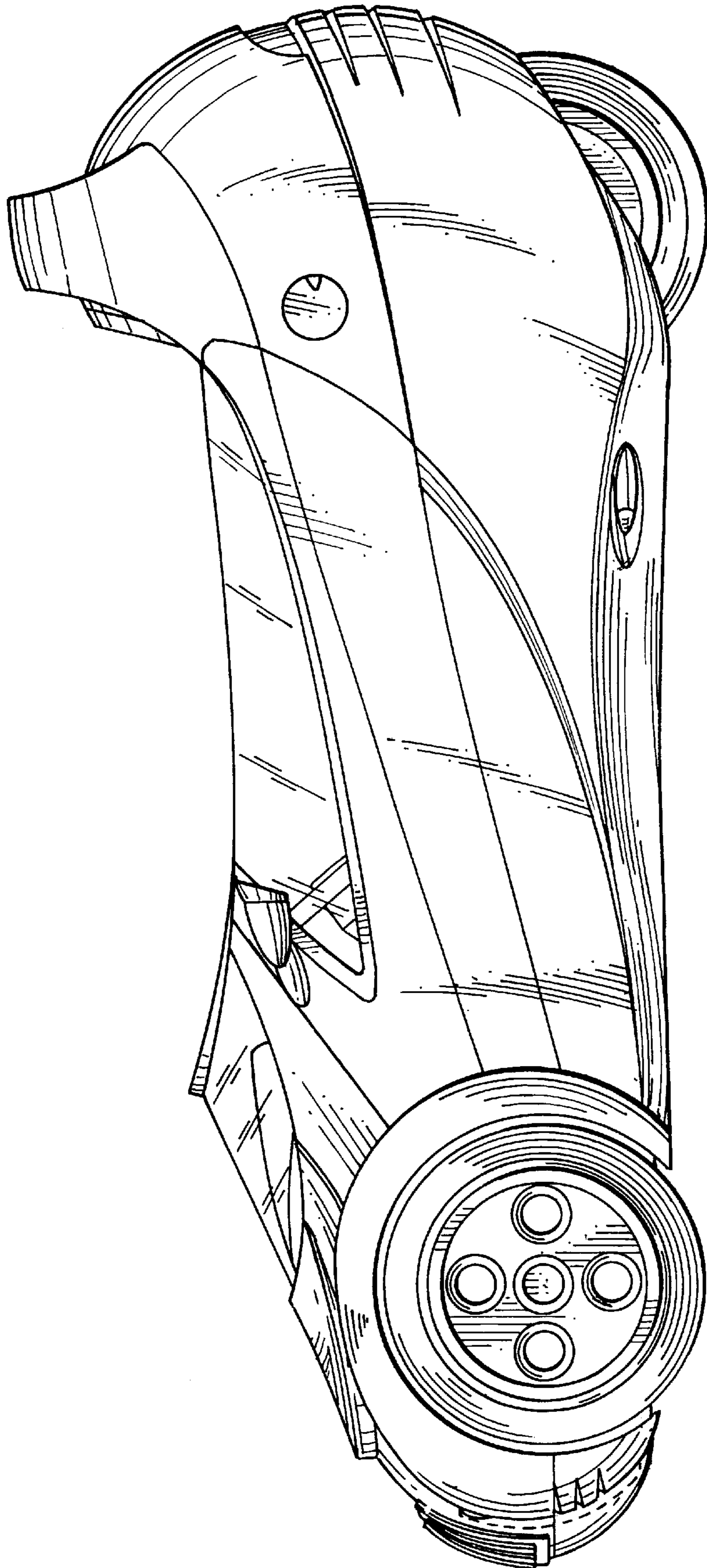

FIG. 9

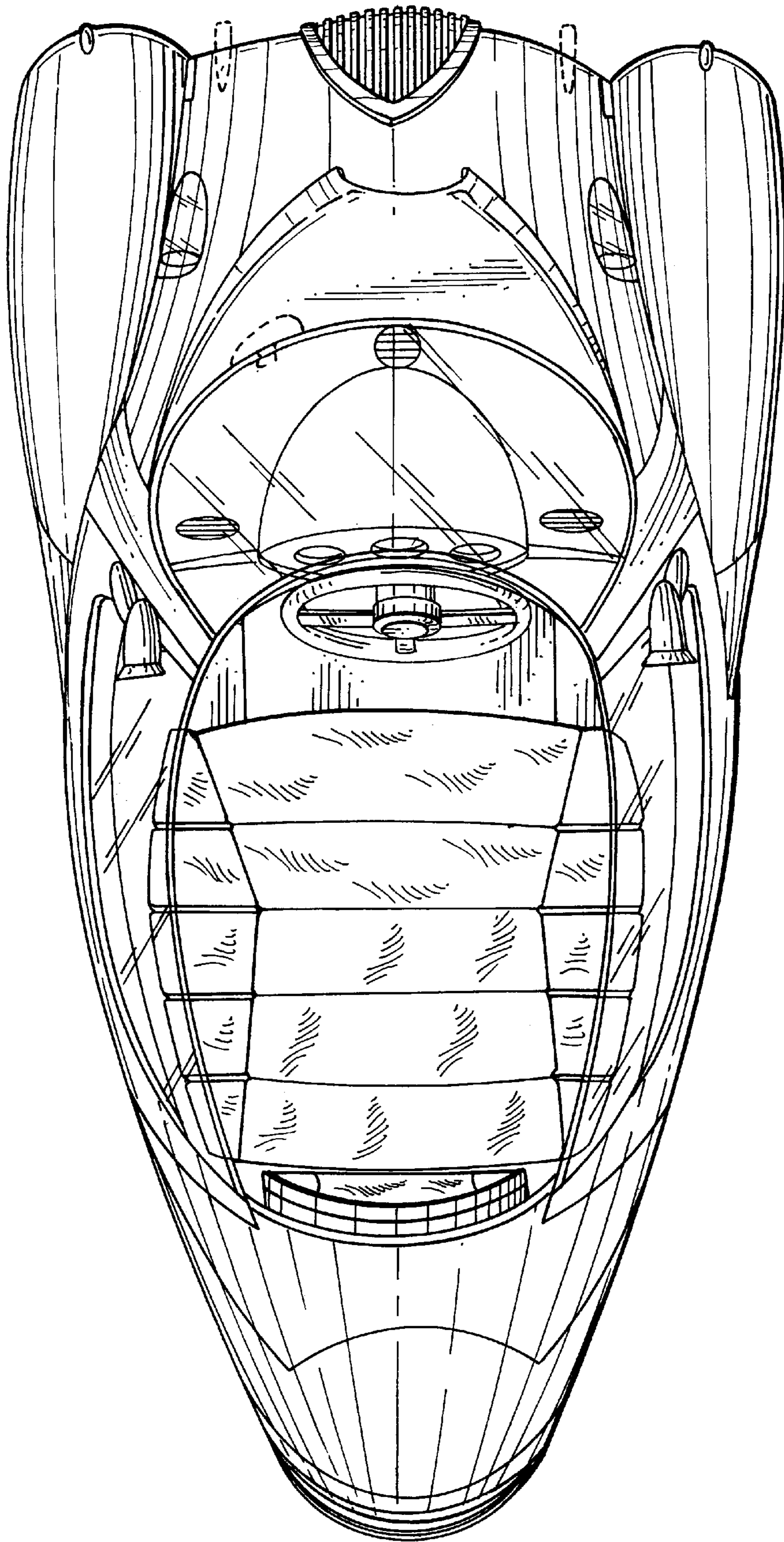

FIG. 10

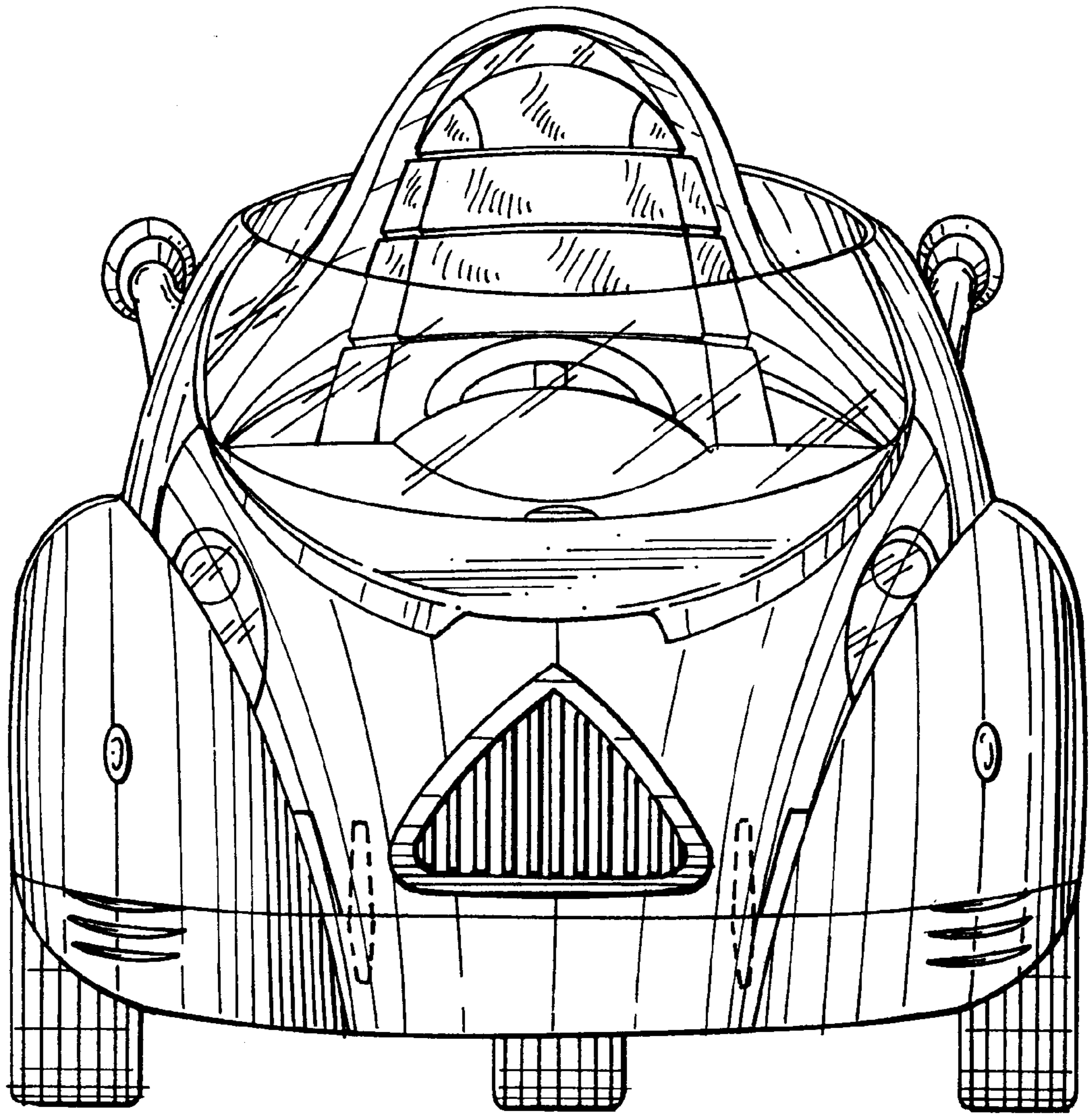

FIG. 11

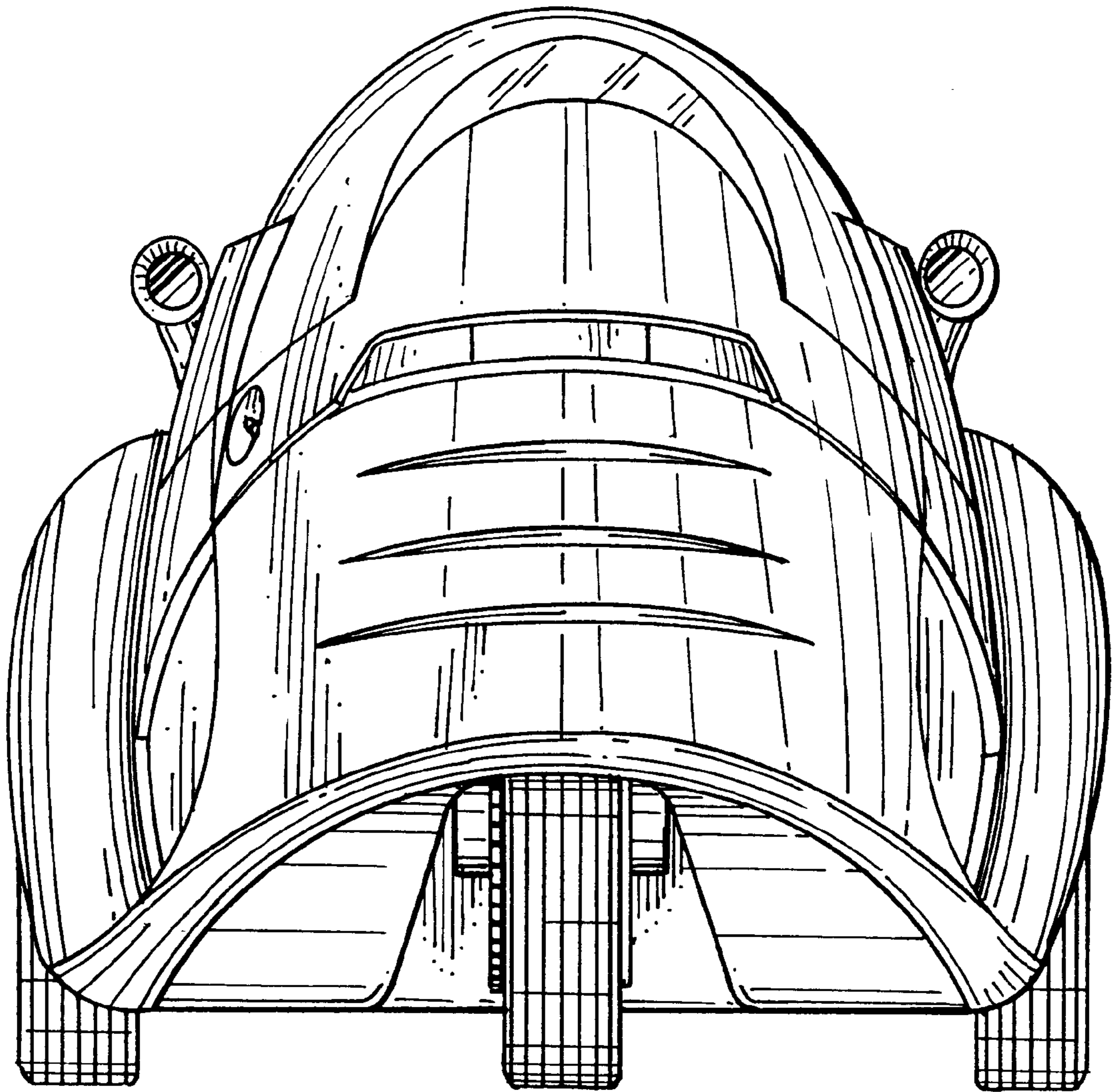

FIG. 12