



US00D424723S

# United States Patent [19]

Hall et al.

[11] **Patent Number: Des. 424,723**

[45] **Date of Patent: \*\* May 9, 2000**

[54] **CLEARANCE/MARKER LAMP FOR A MOTOR VEHICLE**

[75] Inventors: **Phillip J. Hall**, Denton; **Louis D. Heilaneh**, Lewisville; **Glen A. Marshall**, Aubrey; **Richard R. Mihelic**, Lewisville, all of Tex.

[73] Assignee: **Paccar Inc.**, Bellevue, Wash.

[\*\*] Term: **14 Years**

[21] Appl. No.: **29/107,031**

[22] Filed: **Jun. 25, 1999**

[51] **LOC (7) Cl.** ..... **26-02**

[52] **U.S. Cl.** ..... **D26/28**

[58] **Field of Search** ..... D26/28-36; D10/114; 362/61, 74, 80, 80.1, 83, 83.2, 147, 362, 432

### [56] **References Cited**

#### U.S. PATENT DOCUMENTS

- D. 220,360 3/1971 Rossi ..... D26/28
- D. 258,315 2/1981 Alsman ..... D26/28

- D. 266,597 10/1982 Roberts ..... D26/28
- D. 269,210 5/1983 Cutlip et al. .... D26/28
- D. 316,159 4/1991 Whitley, II ..... D26/28
- D. 390,981 2/1998 Kacyorowski et al. .... D26/28

*Primary Examiner*—Marcus A. Jackson  
*Attorney, Agent, or Firm*—Sidley & Austin

### [57] **CLAIM**

The ornamental design for a clearance/marker lamp for a motor vehicle, as shown and described.

### **DESCRIPTION**

FIG. 1 is a perspective view of our clearance/marker lamp for a motor vehicle;  
 FIG. 2 is a top view thereof;  
 FIG. 3 is a right side view thereof, the opposite side view being symmetrical;  
 FIG. 4 is a rear view thereof; and,  
 FIG. 5 is a front view thereof.  
 The broken line showing of electrical lead wires, in FIGS. 1, 3, 4 and 5, and of a fastener hole, in FIGS. 1, 2 and 4, is for illustrative purposes only and forms no part of the claimed design.

**1 Claim, 2 Drawing Sheets**

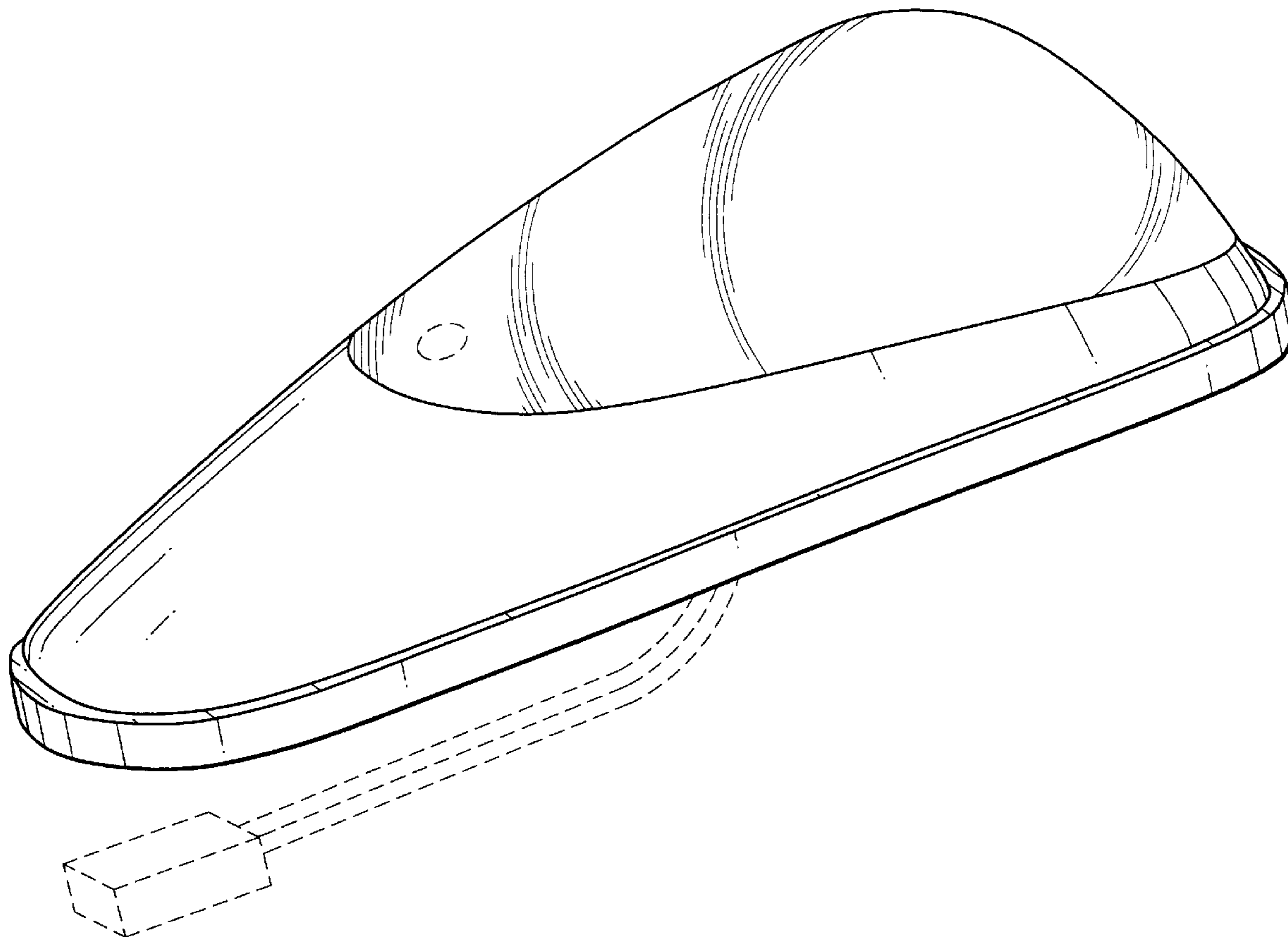

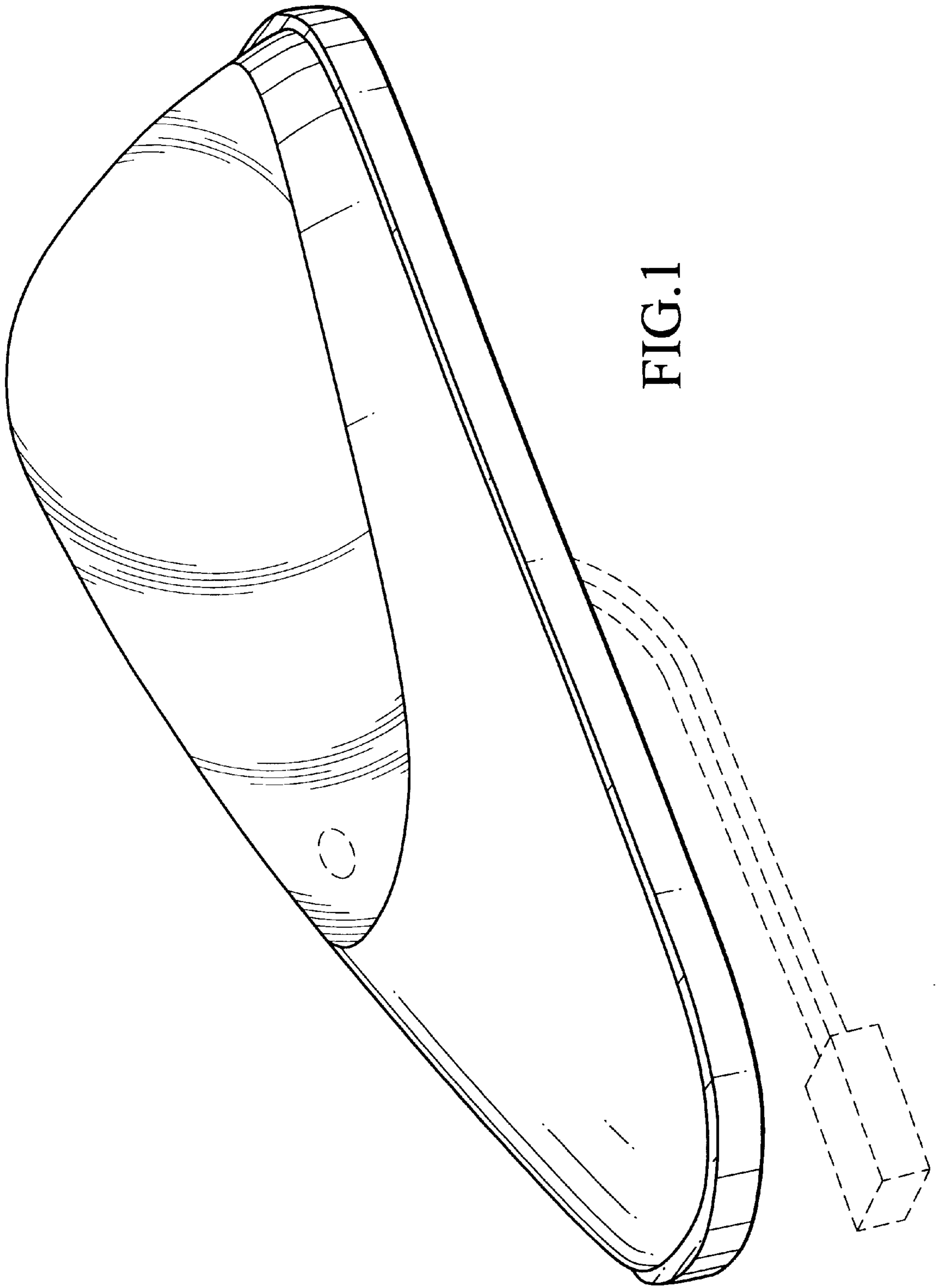

FIG. 1

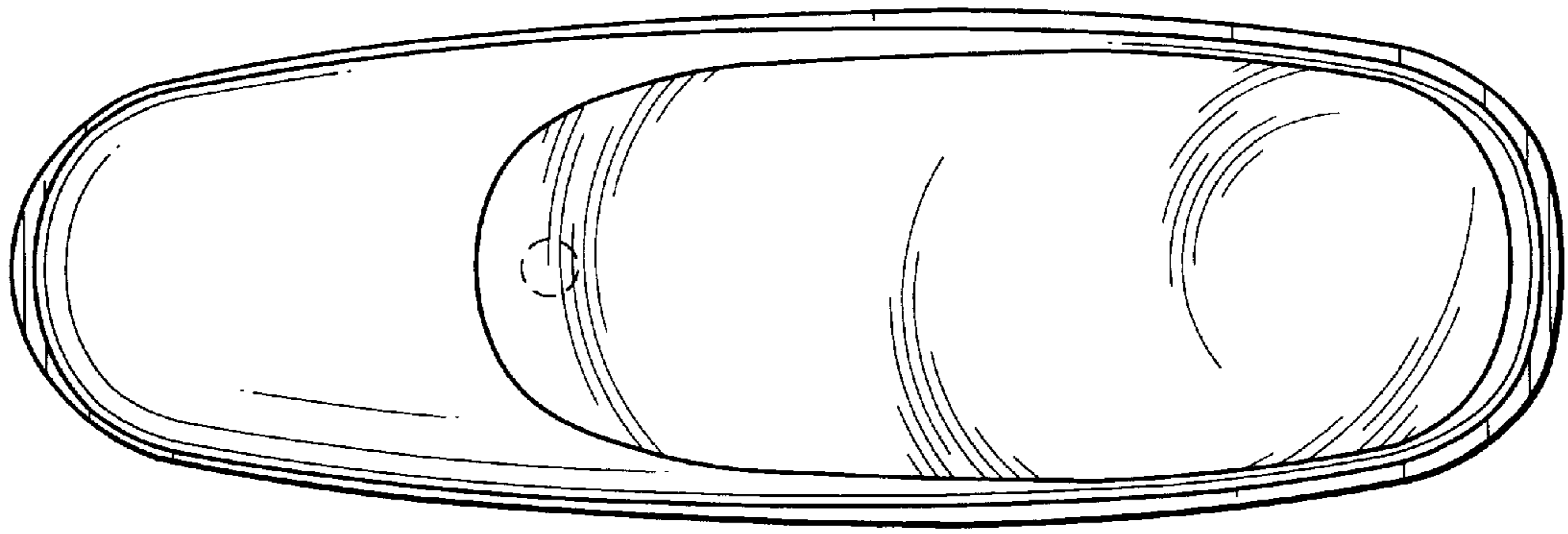

FIG. 2

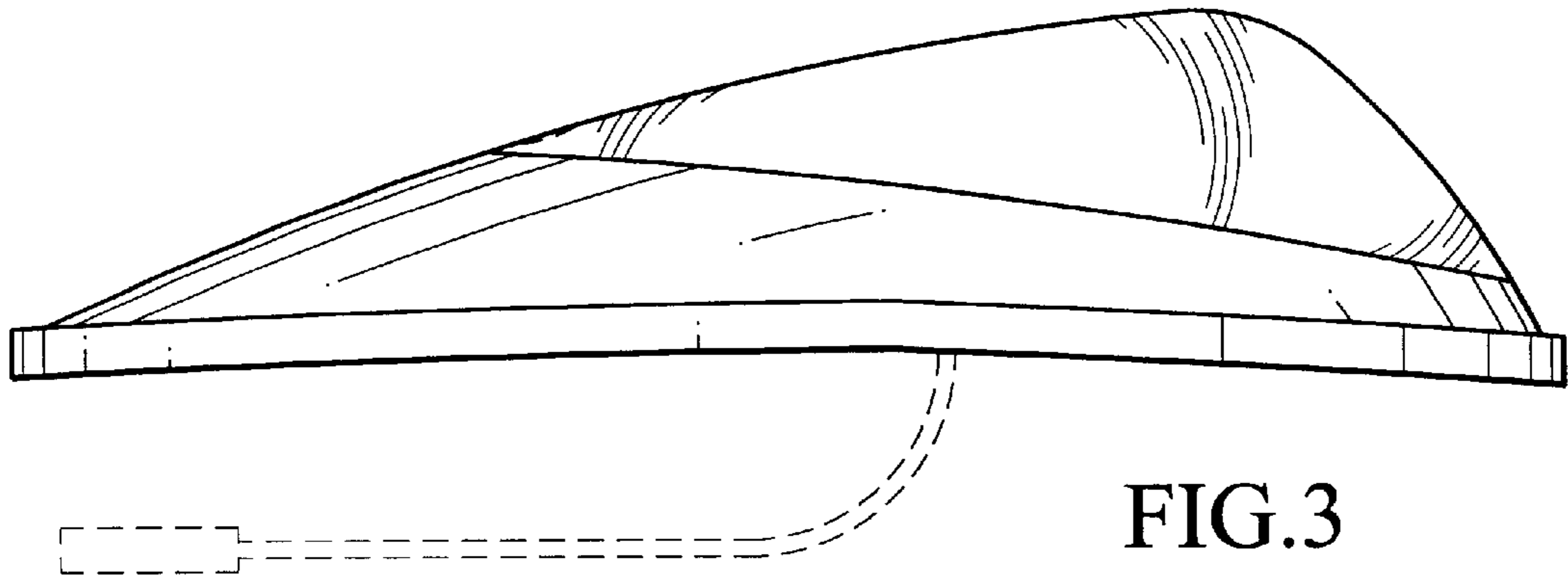

FIG. 3

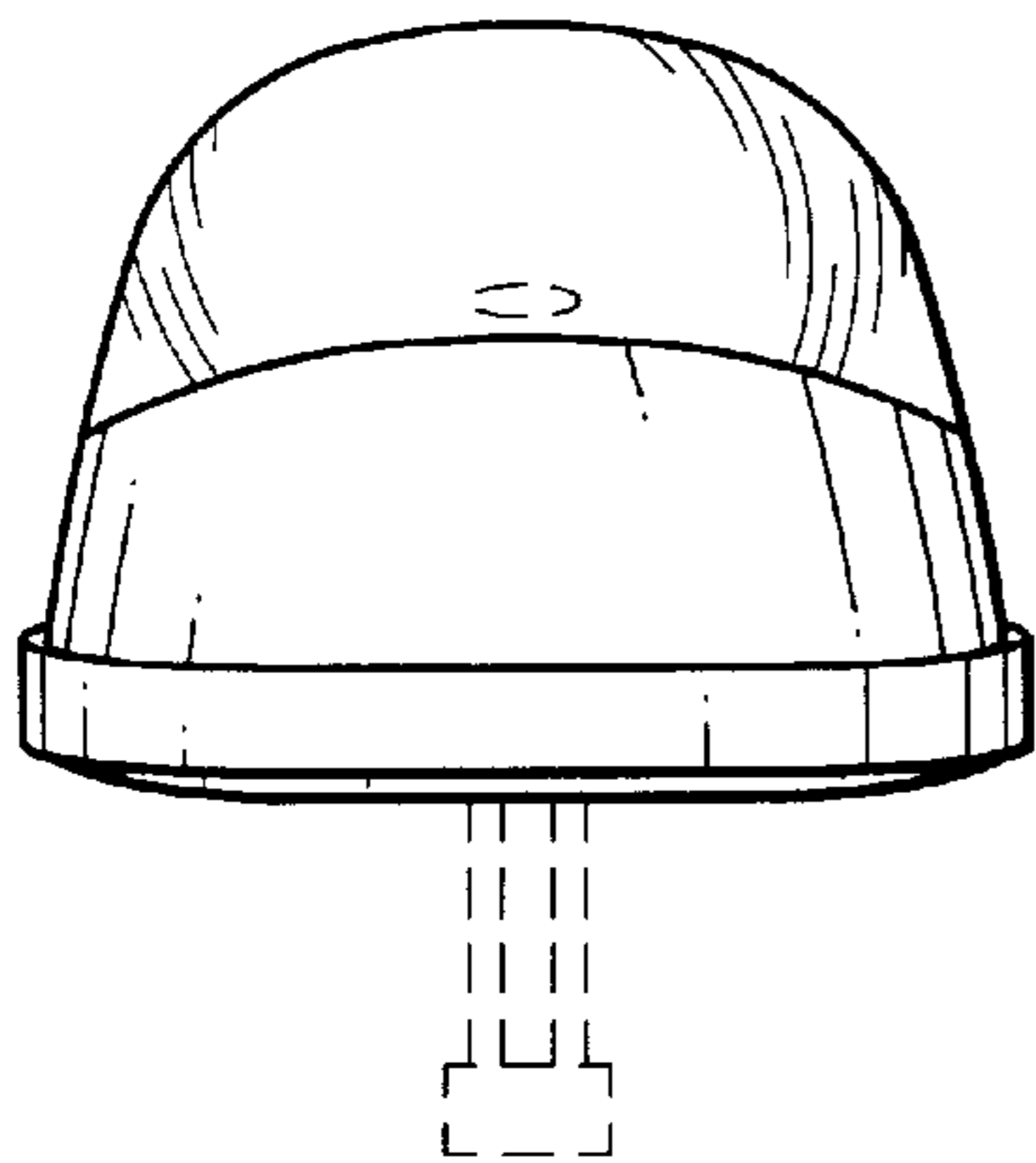

FIG. 4

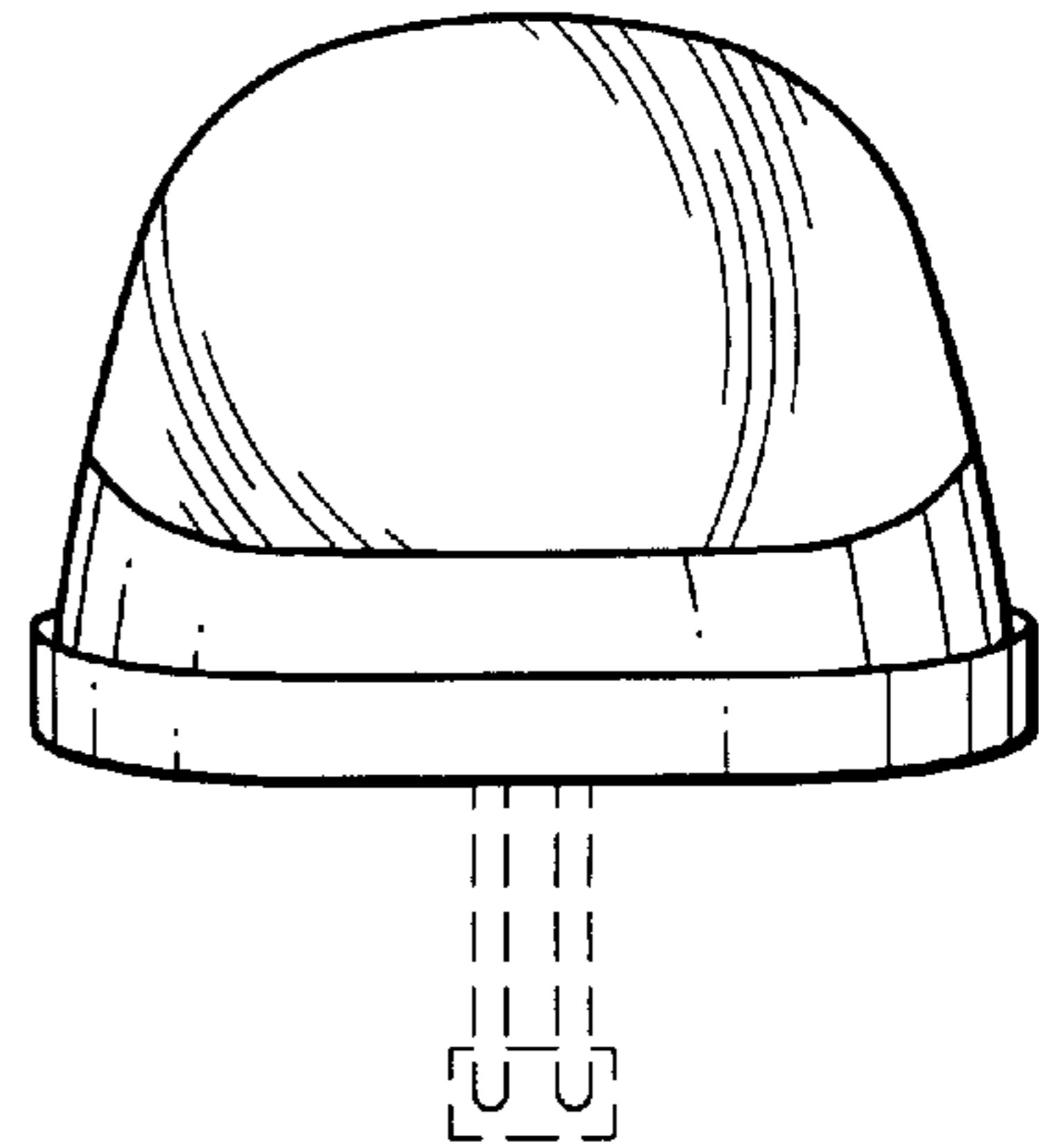

FIG. 5