



US00D424580S

United States Patent [19]

Moehle et al.

[11] **Patent Number: Des. 424,580**

[45] **Date of Patent: ** May 9, 2000**

[54] **WORK VEHICLE CAB**

[75] Inventors: **Kenneth A. Moehle; Darrel J. Svendsen; John M. Zeni**, all of Racine, Wis.

[73] Assignee: **Case Corporation**, Racine, Wis.

[**] Term: **14 Years**

[21] Appl. No.: **29/107,600**

[22] Filed: **Jul. 8, 1999**

[51] **LOC (7) Cl.** **12-16**

[52] **U.S. Cl.** **D15/23**

[58] **Field of Search** D12/96, 14, 1; D15/23, 25; D34/34-37; 180/22, 24, 89.12; 414/788.2, 503, 914; 280/756; 296/102

[56] **References Cited**

U.S. PATENT DOCUMENTS

- D. 256,801 9/1980 Skyer et al. .
- D. 312,693 12/1990 Goyen et al. D15/23
- D. 353,704 12/1994 Bhambra D34/37

- D. 355,423 2/1995 Woods et al. .
- D. 387,068 12/1997 Kato et al. D15/23
- D. 391,581 3/1998 Kato D15/23

Primary Examiner—Melody N. Brown
Attorney, Agent, or Firm—Foley & Lardner

[57] **CLAIM**

The ornamental design for a work vehicle cab, as shown and described.

DESCRIPTION

FIG. 1 is an elevated perspective view as seen from the left front of the work vehicle cab embodying our design; FIG. 2 is a front elevation view of the work vehicle cab; FIG. 3 is a left side elevation view of the work vehicle cab; FIG. 4 is a rear elevation view of the work vehicle cab; FIG. 5 is a top elevation view of the work vehicle cab; and, FIG. 6 is a bottom elevation view of the work vehicle cab. The broken lines shown throughout the drawing are for illustrative purposes only and form no part of the claimed design.

1 Claim, 4 Drawing Sheets

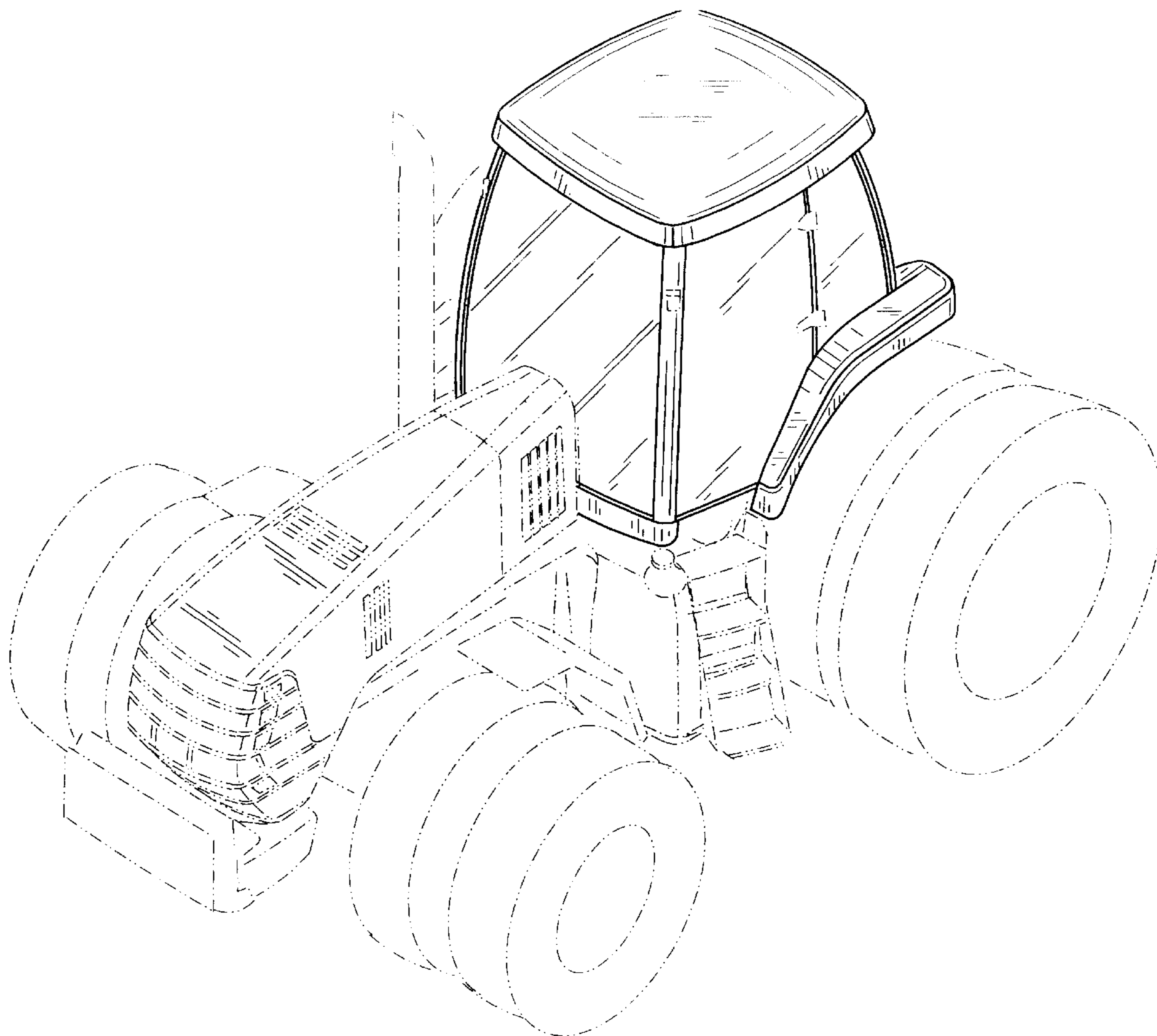

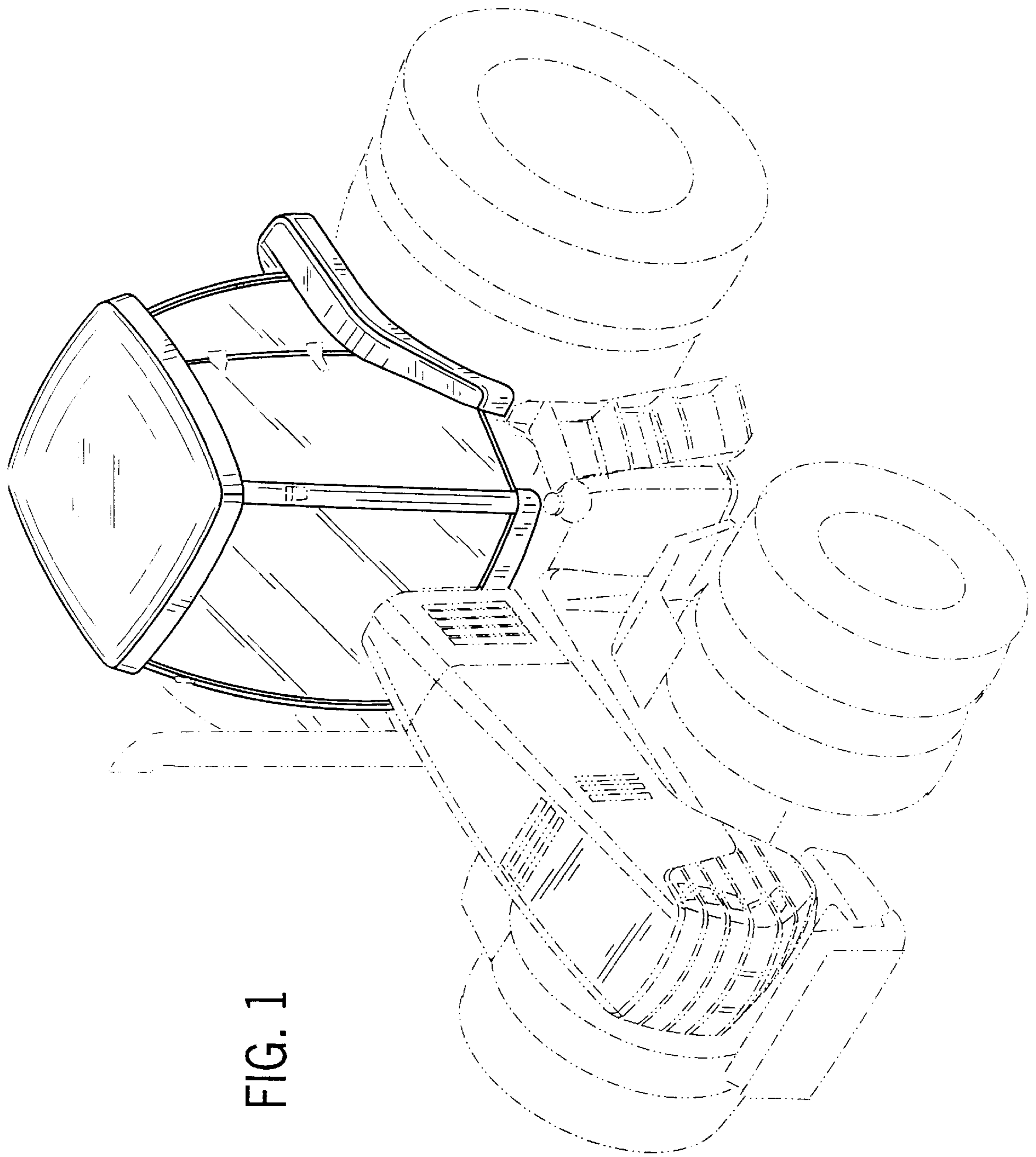

FIG. 1

FIG. 2

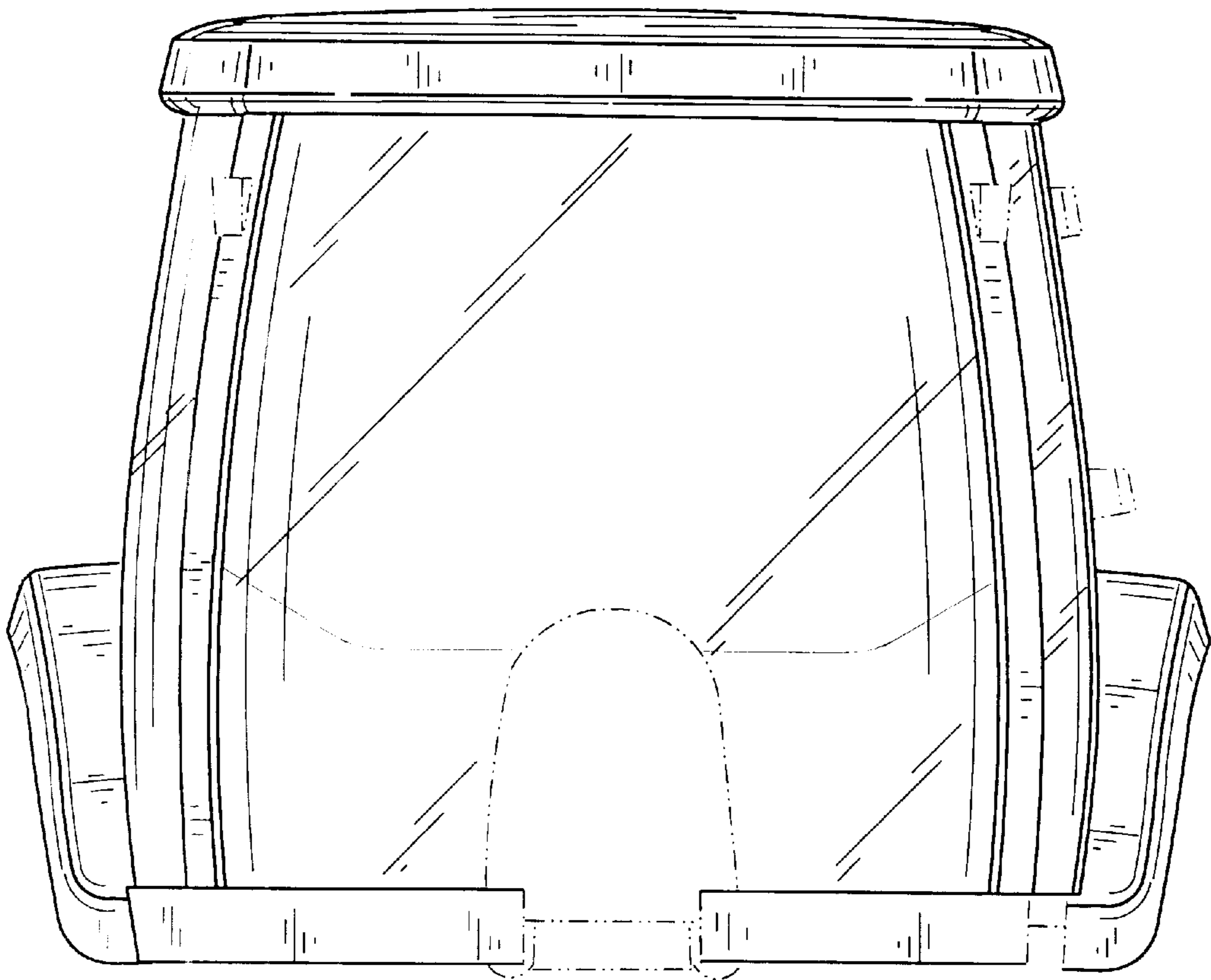

FIG. 3

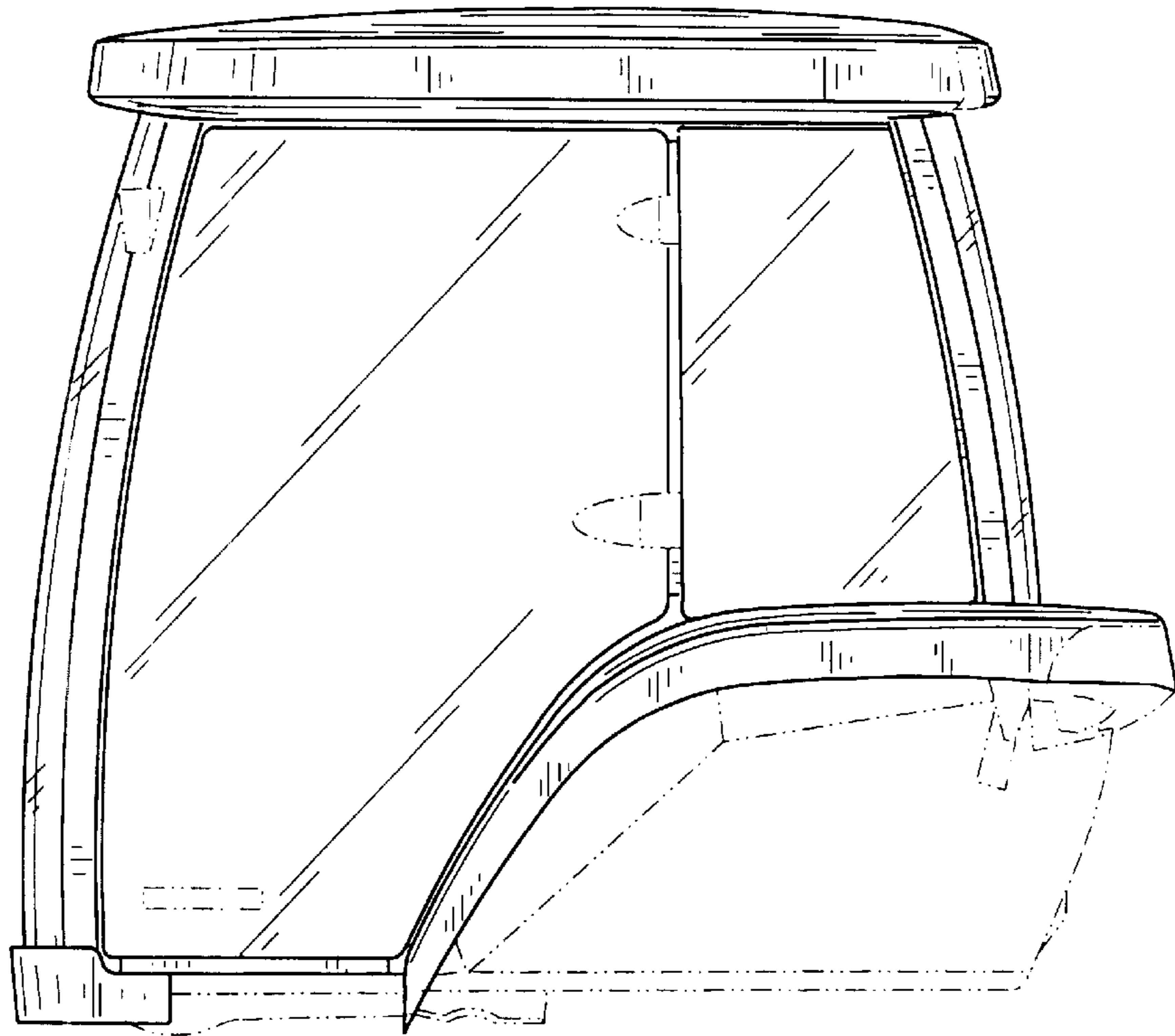

FIG. 4

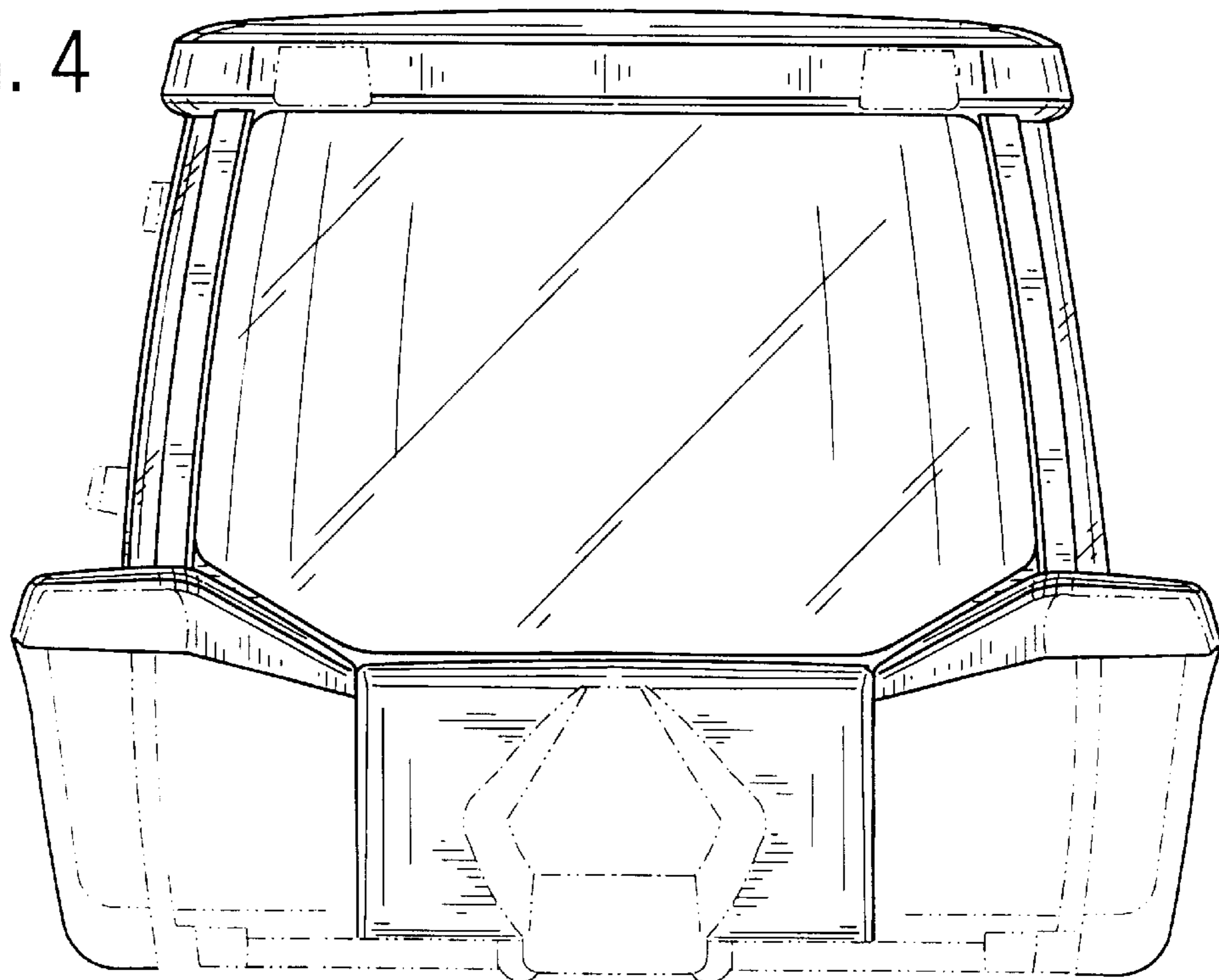

FIG. 5

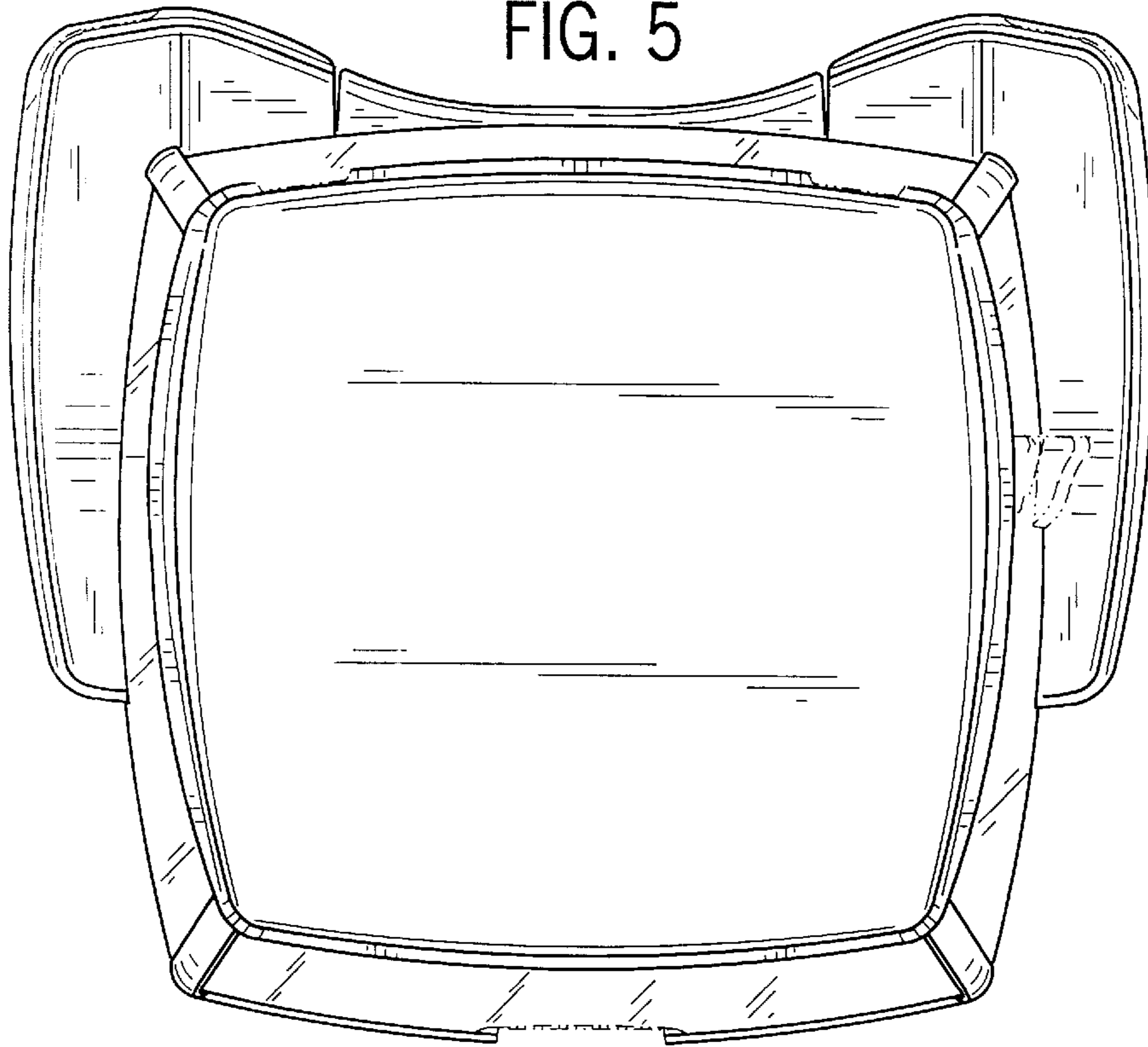

FIG. 6

