



US00D424476S

United States Patent [19]

[11] **Patent Number: Des. 424,476**

Hellhake et al.

[45] **Date of Patent: ** May 9, 2000**

[54] CAB OVER ENGINE TRUCK FRONT EXTERIOR SURFACE

OTHER PUBLICATIONS

[75] Inventors: **Ferdinand F. Hellhake**, Beaverton;
Mark S. Hurayt, Aloha, both of Oreg.;
Joachim Paschke, Gechingen,
Germany; **Sigmun D. Runyon**, Sandy,
Oreg.

Freightliner Corporation Brochure: "Freightliner Cab Over Engine", Copyright 1988.

Freightliner Corporation Brochure: "The New Freightliner C.O.E.", Copyright 1993.

Freightliner Corporation Brochure: "You Expect More From Freightliner. And You Should" (depicting prior art vehicle).

[73] Assignee: **Freightliner Corporation**, Portland,
Oreg.

Primary Examiner—Melody N. Brown

Attorney, Agent, or Firm—Klarquist Sparkman Campbell
Leigh & Winston, LLP

[**] Term: **14 Years**

[57] CLAIM

[21] Appl. No.: **29/093,604**

We claim the ornamental design for a cab over engine truck front exterior surface as shown and described.

[22] Filed: **Sep. 15, 1998**

DESCRIPTION

[51] **LOC (7) Cl.** **12-08**

[52] **U.S. Cl.** **D12/96**

[58] **Field of Search** D12/96, 97; 296/190;
180/89.127, 89.14, 89.16, 89.19

FIG. 1 is a perspective view of a cab over engine truck front exterior surface in accordance with the present invention.

FIG. 2 is a left side view of the cab over engine truck front exterior surface of FIG. 1, it being understood that the right side view is the mirror image of the left side view.

FIG. 3 is a top view of the cab over engine truck front exterior surface of FIG. 1.

FIG. 4 is a bottom view of the cab over engine truck front exterior surface of FIG. 1. and,

FIG. 5 is a front view of the cab over engine truck front exterior surface of FIG. 1.

The truck portions shown in broken lines are for illustrative purposes only and form no part of the claimed design.

[56] References Cited

U.S. PATENT DOCUMENTS

D. 302,257	7/1989	Breitschwerdt et al.	D12/96
D. 344,472	2/1994	Savio	D12/96
D. 367,443	2/1996	Sacco et al.	D12/96
D. 394,026	5/1998	Hellhake et al.	D12/96
D. 399,791	10/1998	Hellhake et al.	D12/96
D. 399,792	10/1998	Hellhake et al.	D12/96
D. 406,552	3/1999	Hellhake et al.	D12/93
D. 406,553	3/1999	Hellhake et al.	D12/96
D. 408,331	4/1999	Sacco et al.	D12/96
4,143,732	3/1979	Lettemann et al.	180/68.6

1 Claim, 5 Drawing Sheets

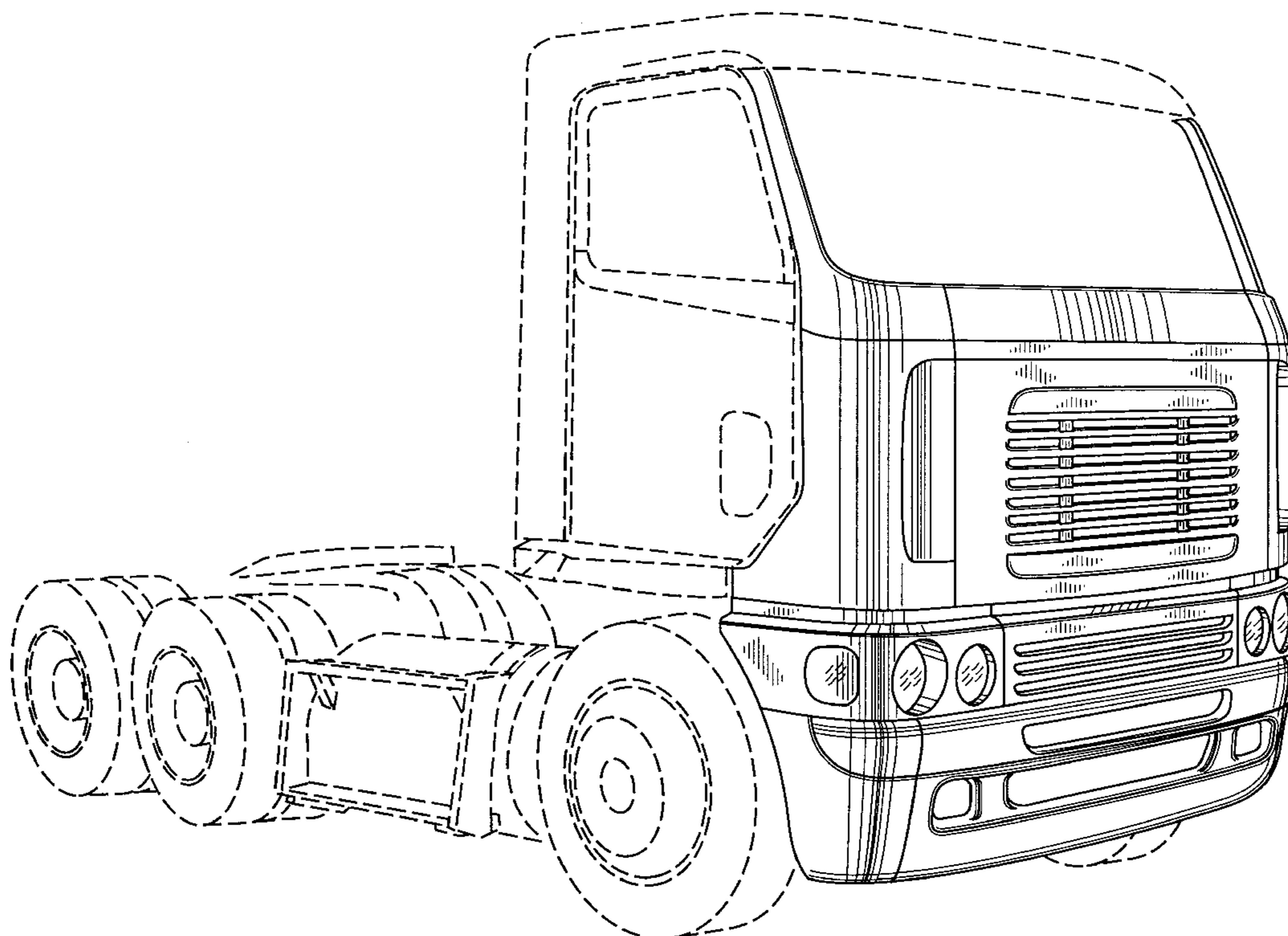

FIG. 1

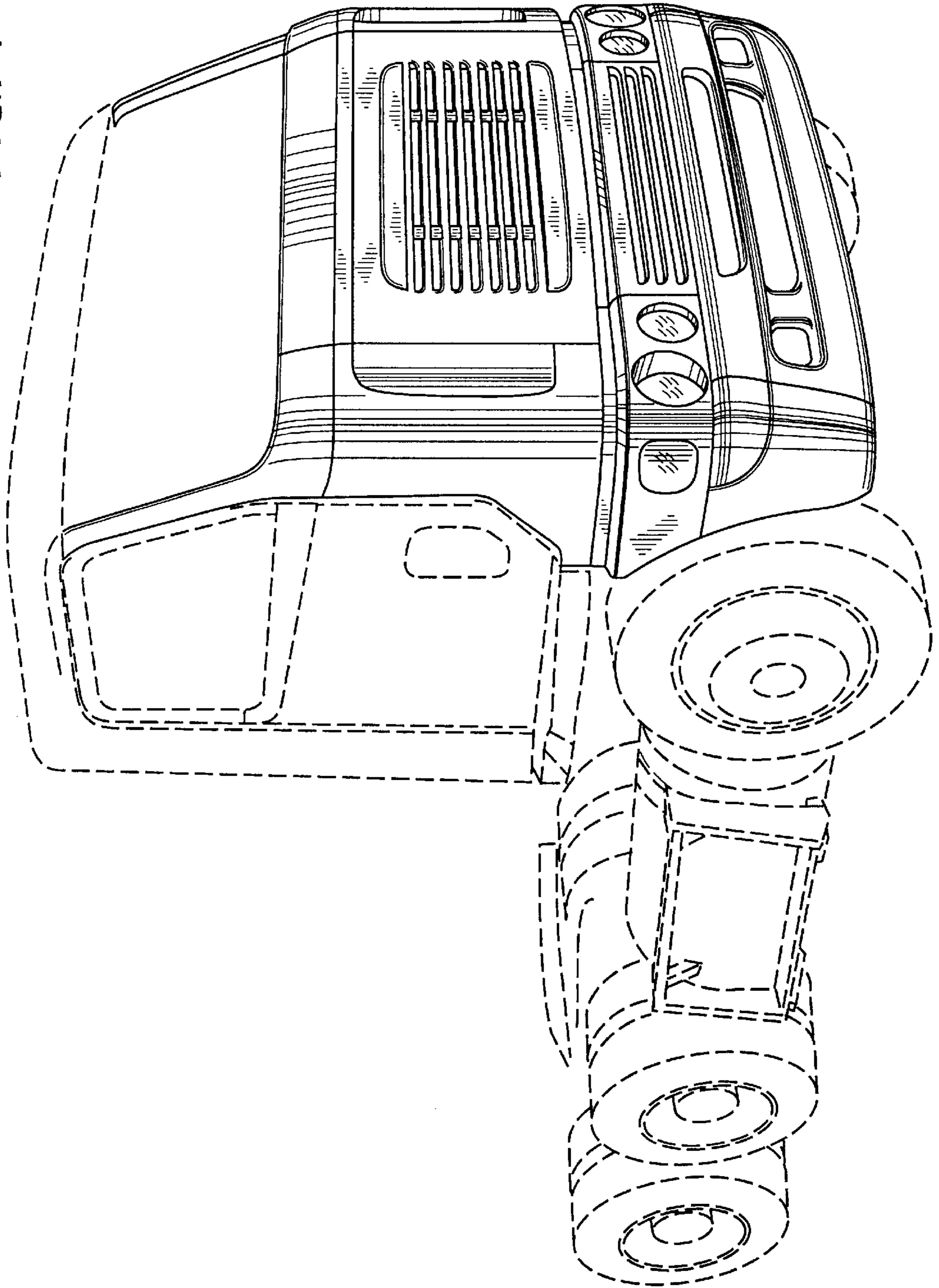

FIG. 2

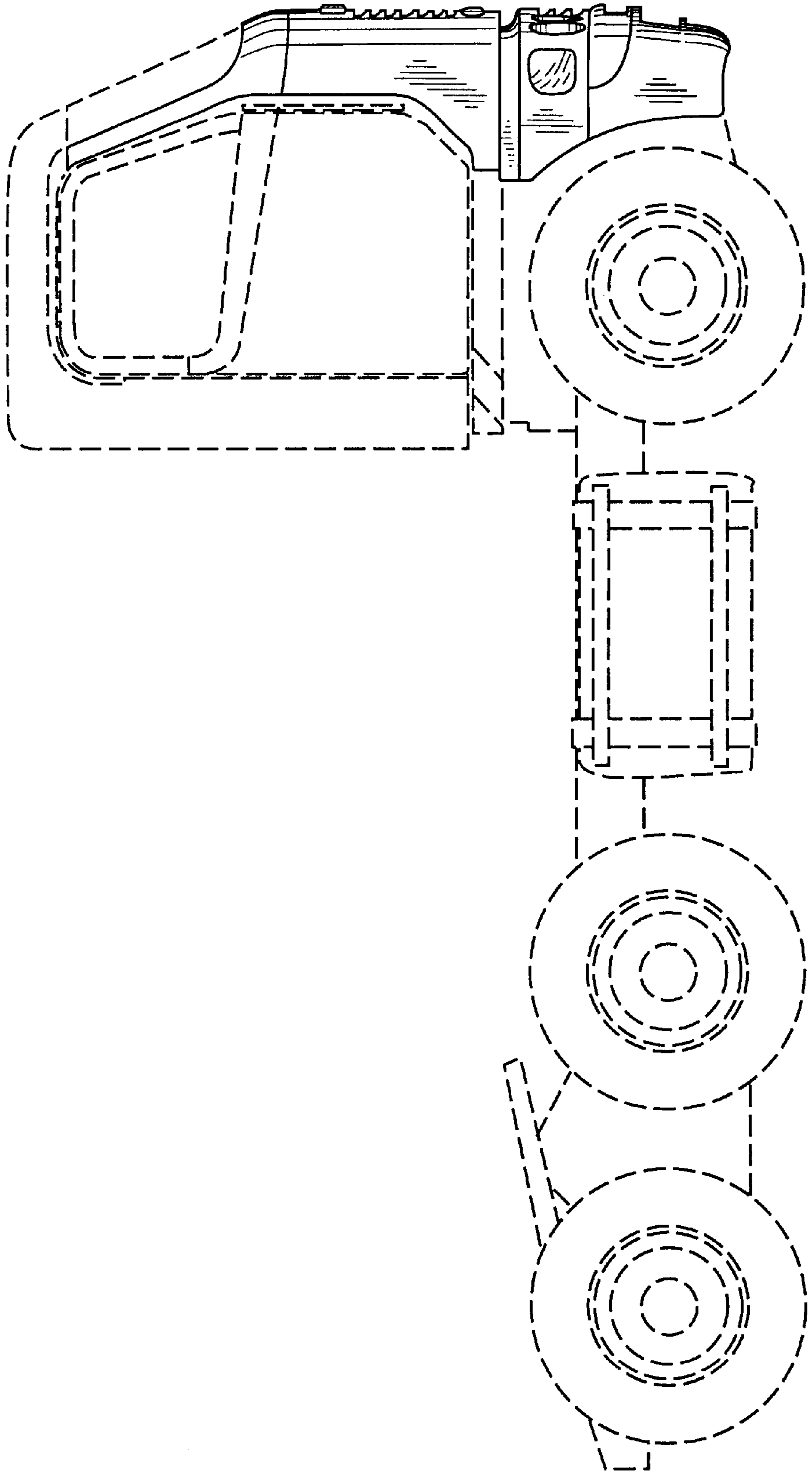

FIG. 3

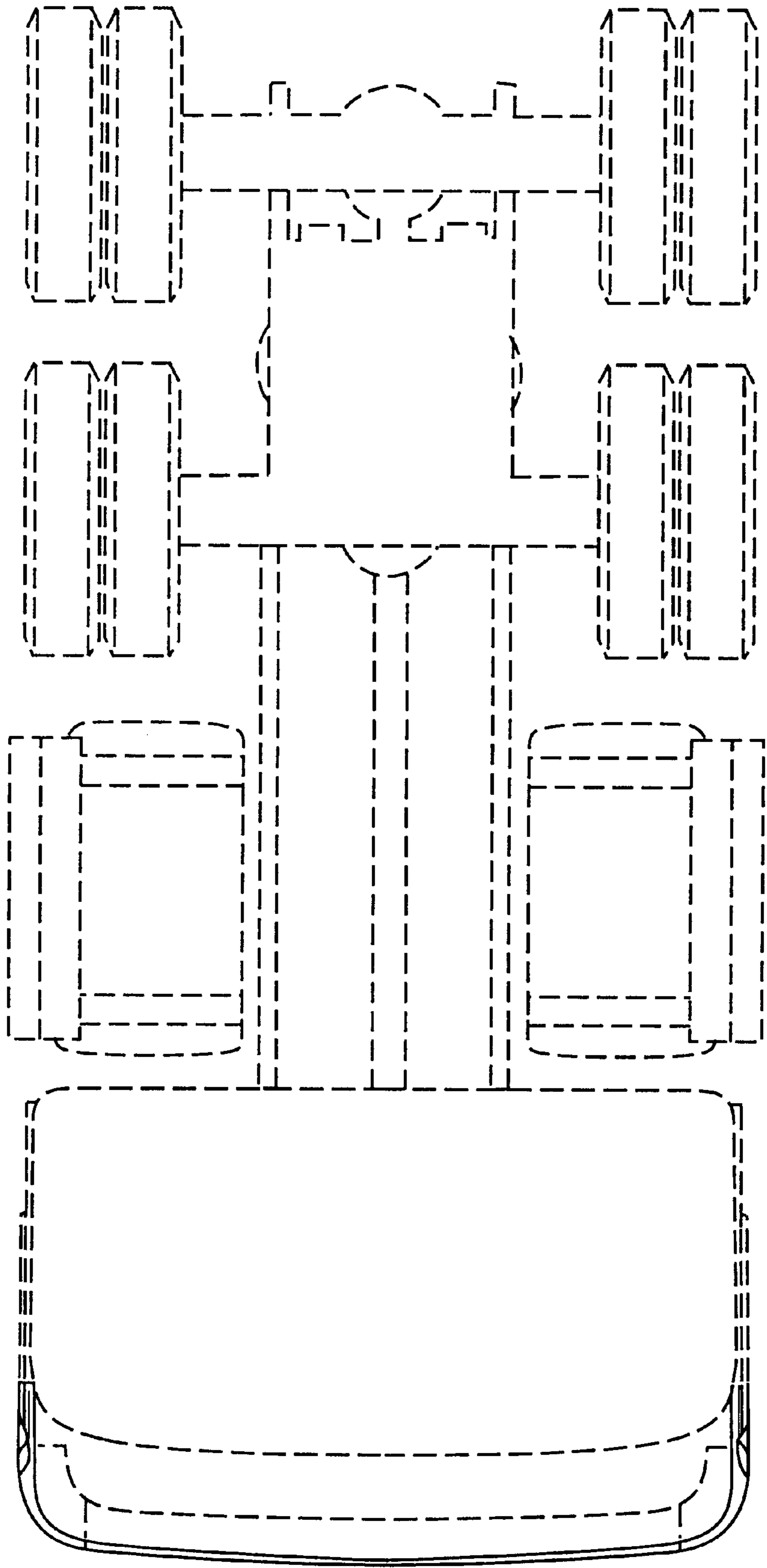

FIG. 4

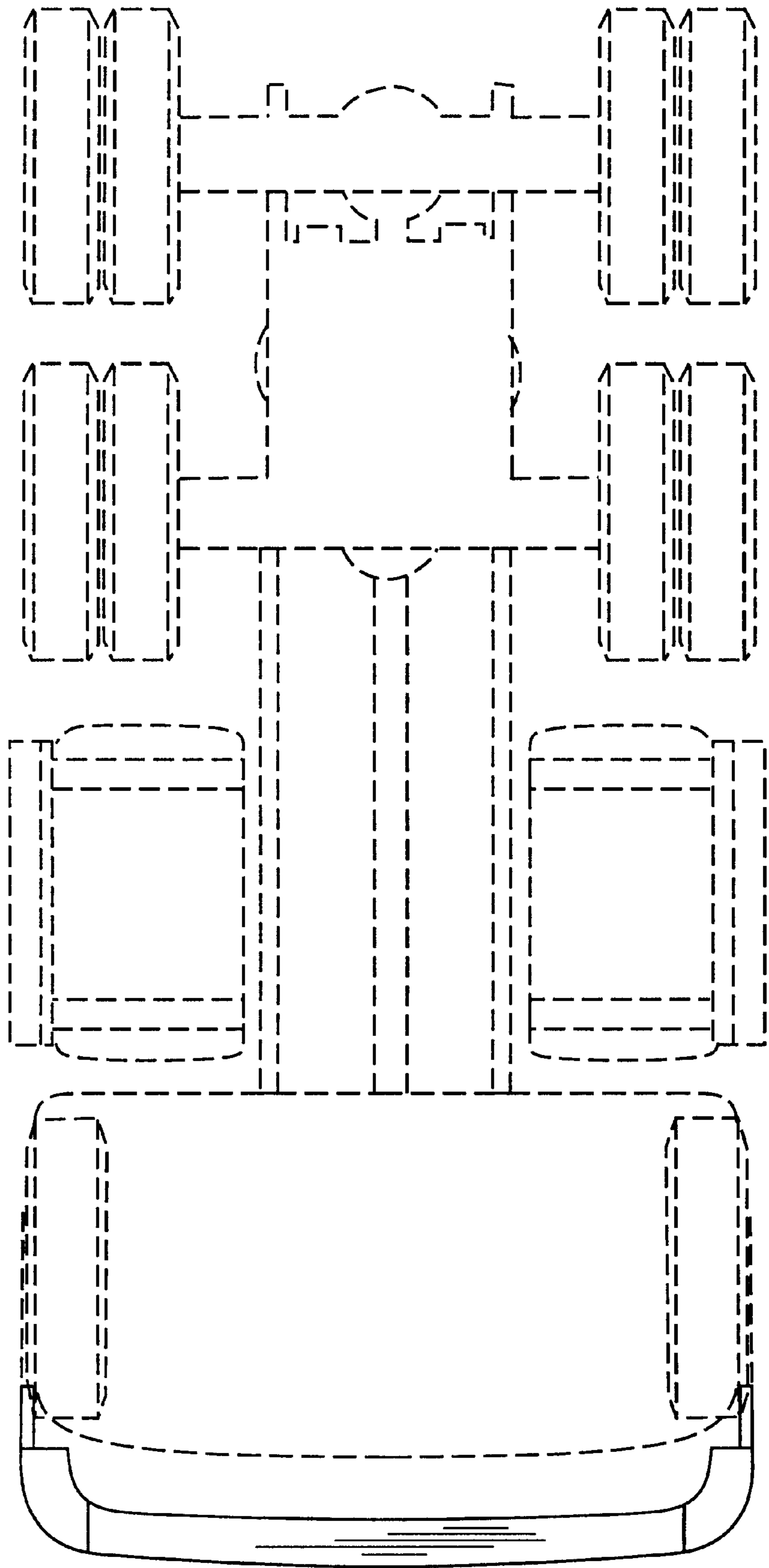

FIG. 5

