



US00D424431S

United States Patent [19] Suzuki

[11] **Patent Number: Des. 424,431**

[45] **Date of Patent: ** May 9, 2000**

[54] **CASE FOR A REMOTELY CONTROLLED TOY VEHICLE**

5,350,058 9/1994 Keough .
5,547,421 8/1996 Scheetz 206/335 X
5,769,680 6/1998 Hoffman .

[75] Inventor: **Masaki Suzuki**, Tokyo, Japan

FOREIGN PATENT DOCUMENTS

[73] Assignee: **Taiyo Kogyo Company, Ltd.**, Tokyo, Japan

04-18589 A 2/1992 Japan .

[**] Term: **14 Years**

Primary Examiner—Prabhakar Deshmukh
Attorney, Agent, or Firm—Akin, Gump, Strauss, Hauer & Feld, L.L.P.

[21] Appl. No.: **29/093,574**

[22] Filed: **Sep. 14, 1998**

[57] CLAIM

[30] Foreign Application Priority Data

Mar. 17, 1998 [JP] Japan 10-7253

The ornamental design for a case for a remotely controlled toy vehicle, as shown and described.

[51] **LOC (7) Cl.** **09-07**

DESCRIPTION

[52] **U.S. Cl.** **D9/428; D21/324**

[58] **Field of Search** D9/428, 429, 414, D9/337; D3/201, 254; 206/335, 305, 525, 769, 770, 775, 776; 220/505, 616, 630, 62.11, 629, 918, 626, 627, 682; 446/73, 75; 229/162; D21/324.32, 333, 533, 548, 549; 463/1, 29, 46, 47; D14/117.1, 114

FIG. 1 is a front elevational view of a case for a remotely controlled toy vehicle in accordance with my new design, the rear elevation and bottom plan views being identical thereto;

FIG. 2 is a top plan view thereof;

FIG. 3 is a left side elevational view thereof;

FIG. 4 is a right side elevational view thereof;

FIG. 5 is a cross sectional view thereof taken along lines 5-5 in FIG. 6 showing an internal structure thereof with screw bosses holding together a pair of hemispherical shells, each with one semicircular end;

FIG. 6 is a cross sectional view thereof taken along lines 6-6 in FIG. 1 also showing the internal structure thereof;

FIG. 7 is a perspective exploded view thereof from the front and right sides showing three parts of the case: outer cap, inner cap and container; and,

FIG. 8 is a right side elevational view thereof with the outer cap thereof removed to reveal the inner cap thereof in the form of a hand control unit of the toy.

The broken line showing of vehicle is for illustrative purposes only and forms no part of the claimed design.

[56] References Cited

U.S. PATENT DOCUMENTS

D. 406,757 3/1999 Bean et al. D9/423
1,983,322 12/1934 Stewart .
2,809,331 10/1957 Canty et al. 220/626 X
3,474,803 10/1969 Davis 206/335 X
4,433,504 2/1984 Terui .
4,555,867 12/1985 Hippely .
4,792,046 12/1988 Taylor 220/682 X
4,905,828 3/1990 Dods .
4,914,034 4/1990 Welsh et al. 206/305 X
5,000,318 3/1991 Kupersmit 206/335
5,094,646 3/1992 Marceau .
5,226,558 7/1993 Whitney et al. 220/638
5,261,848 11/1993 Kaplan et al. .

1 Claim, 3 Drawing Sheets

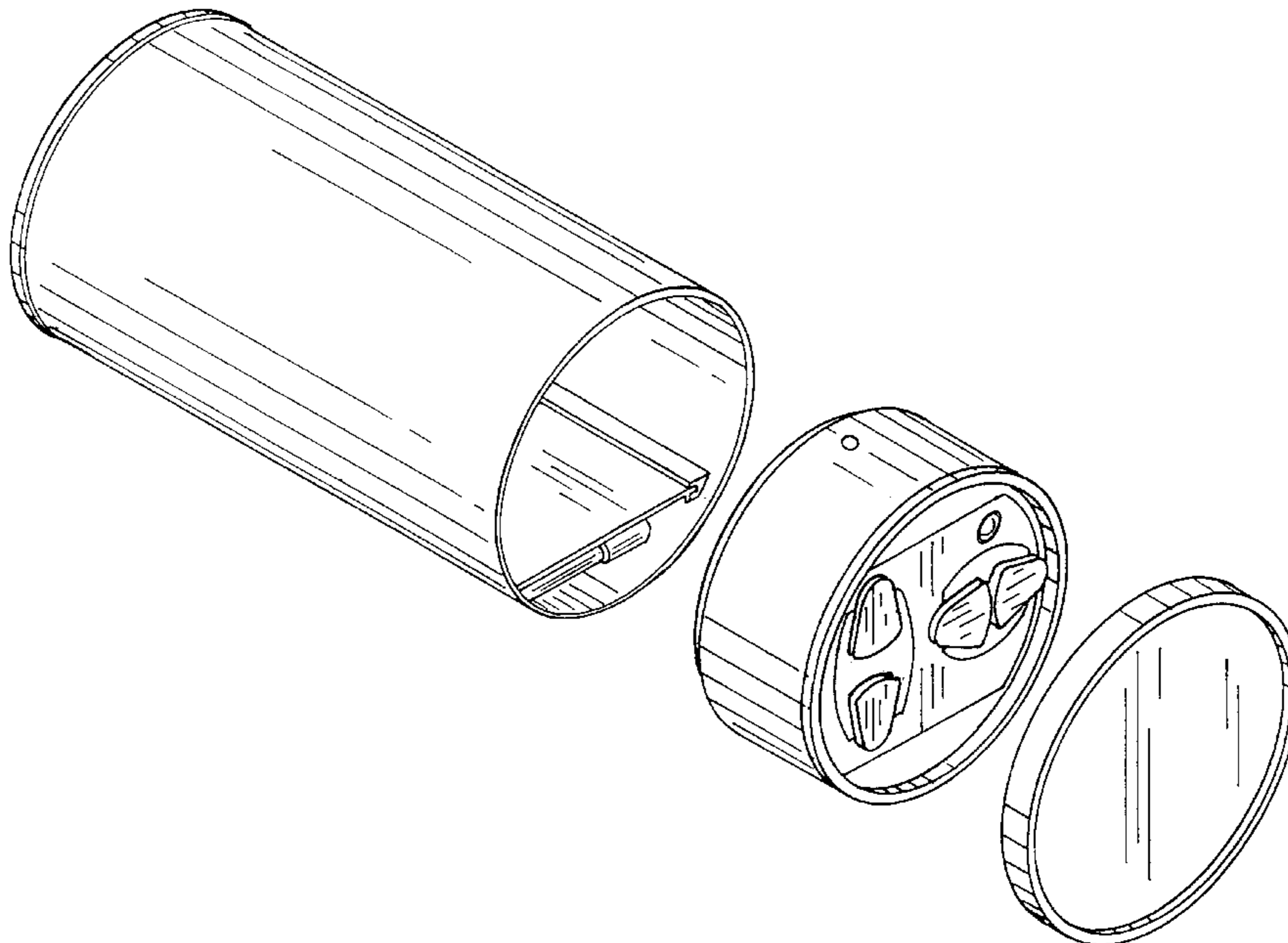

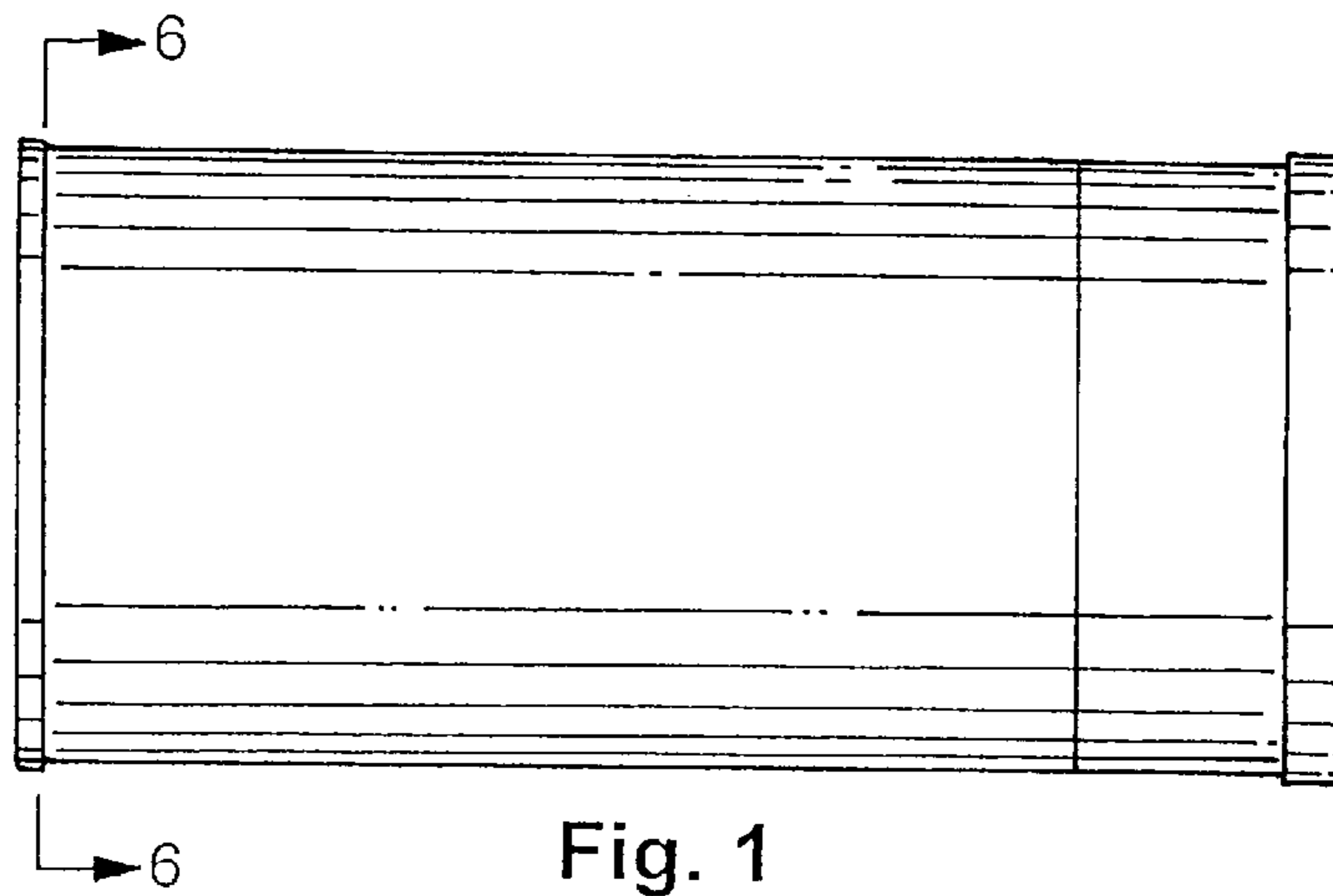

Fig. 1

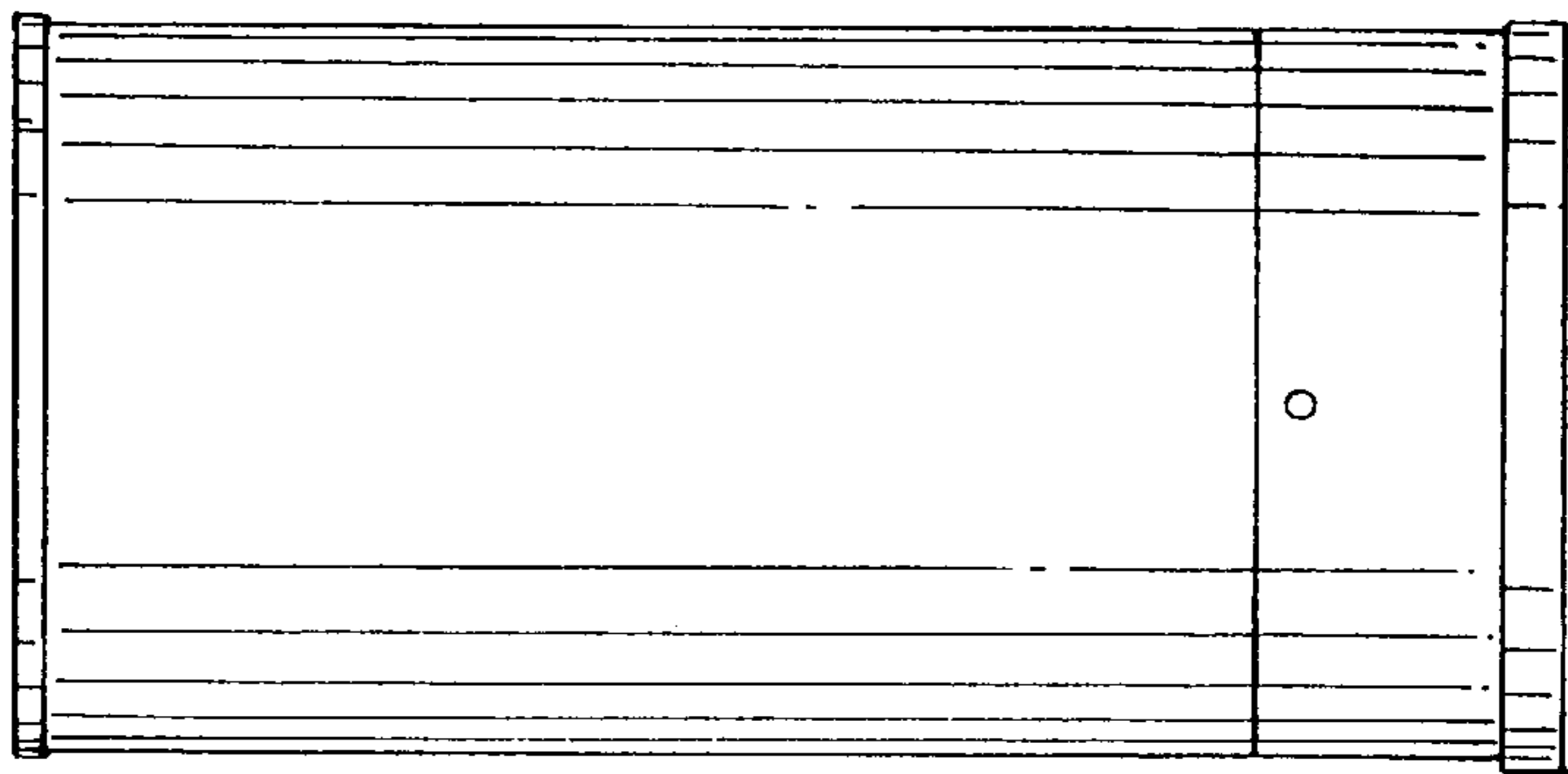

Fig. 2

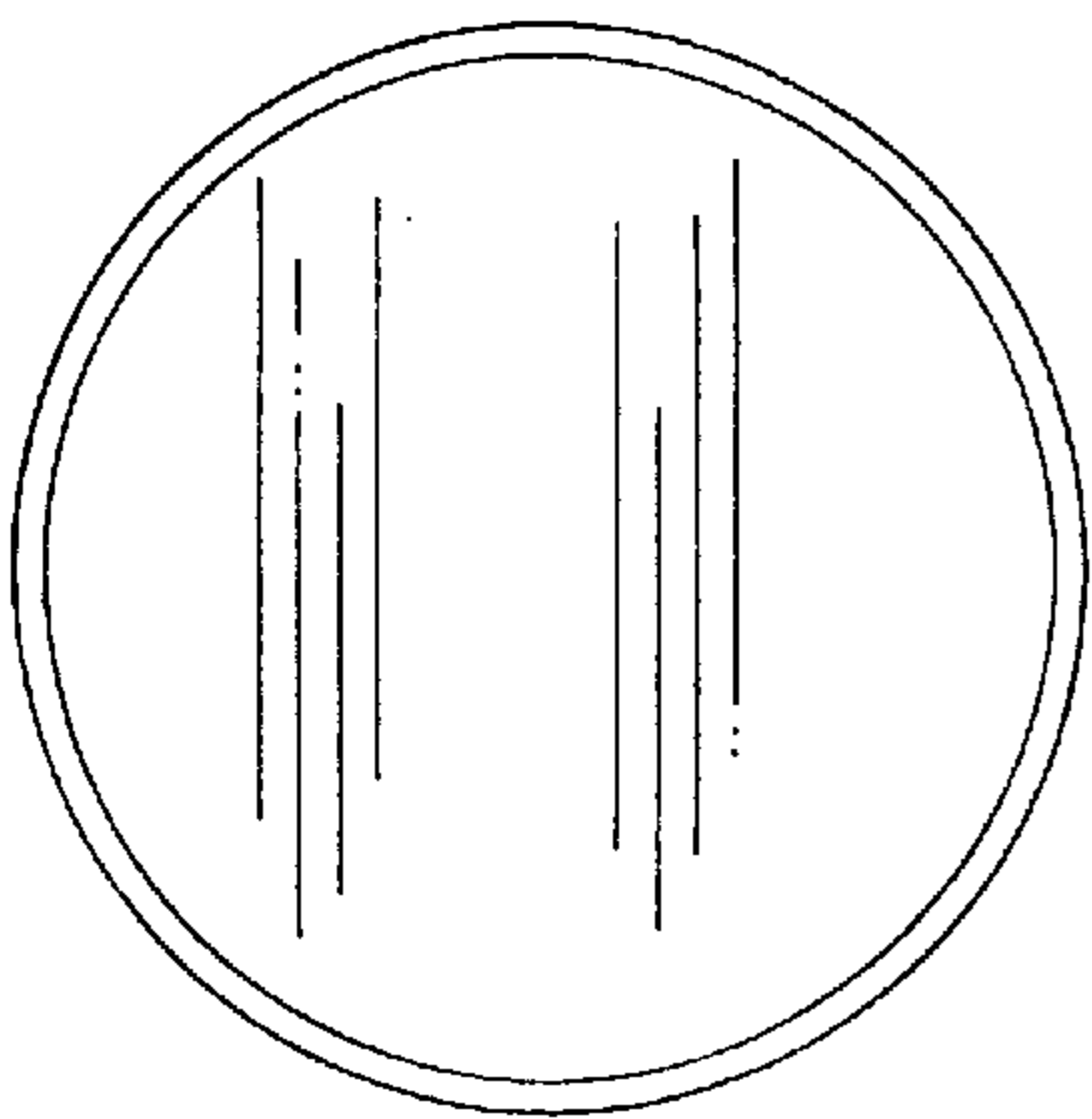

Fig. 3

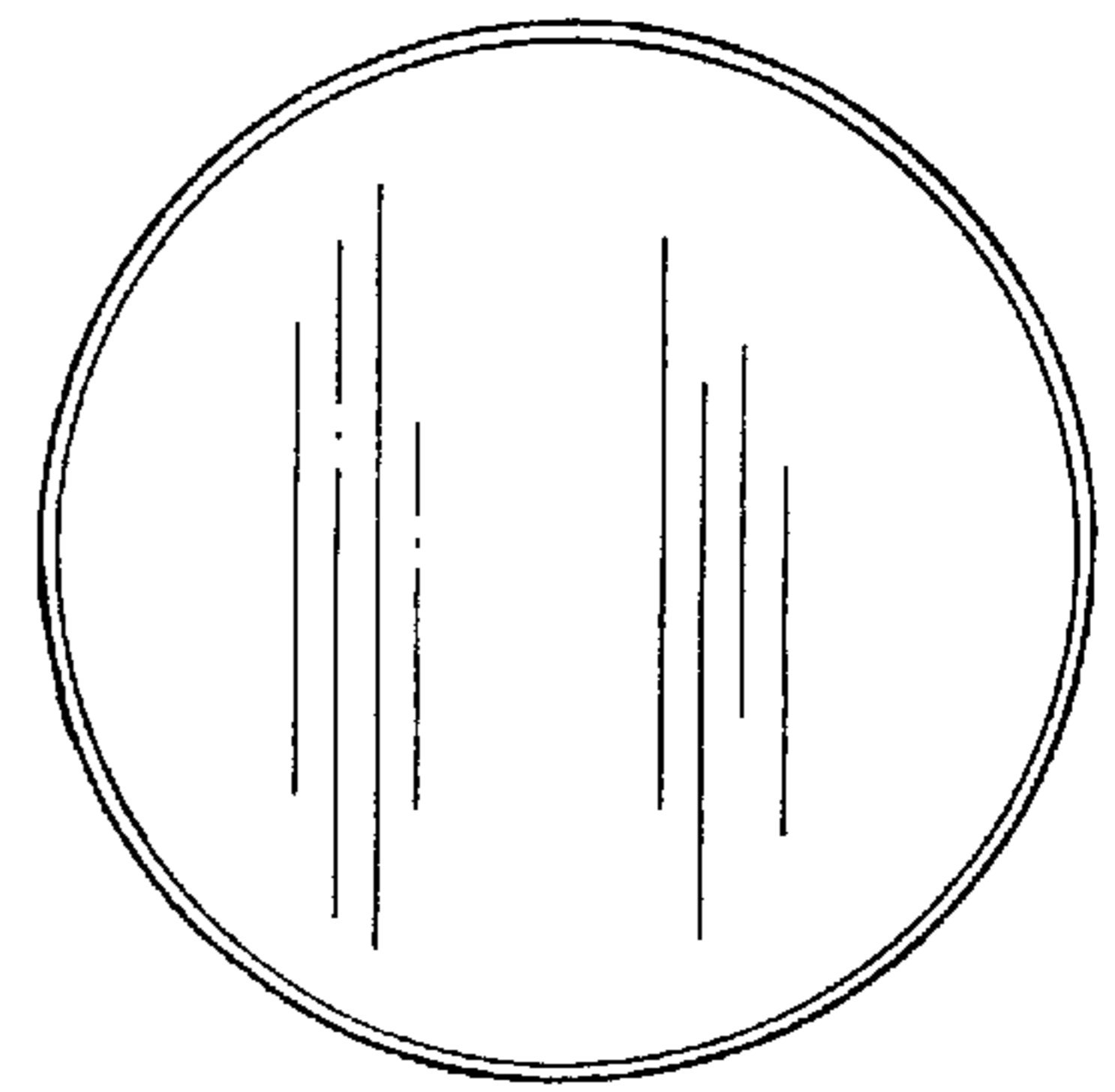

Fig. 4

Fig. 5

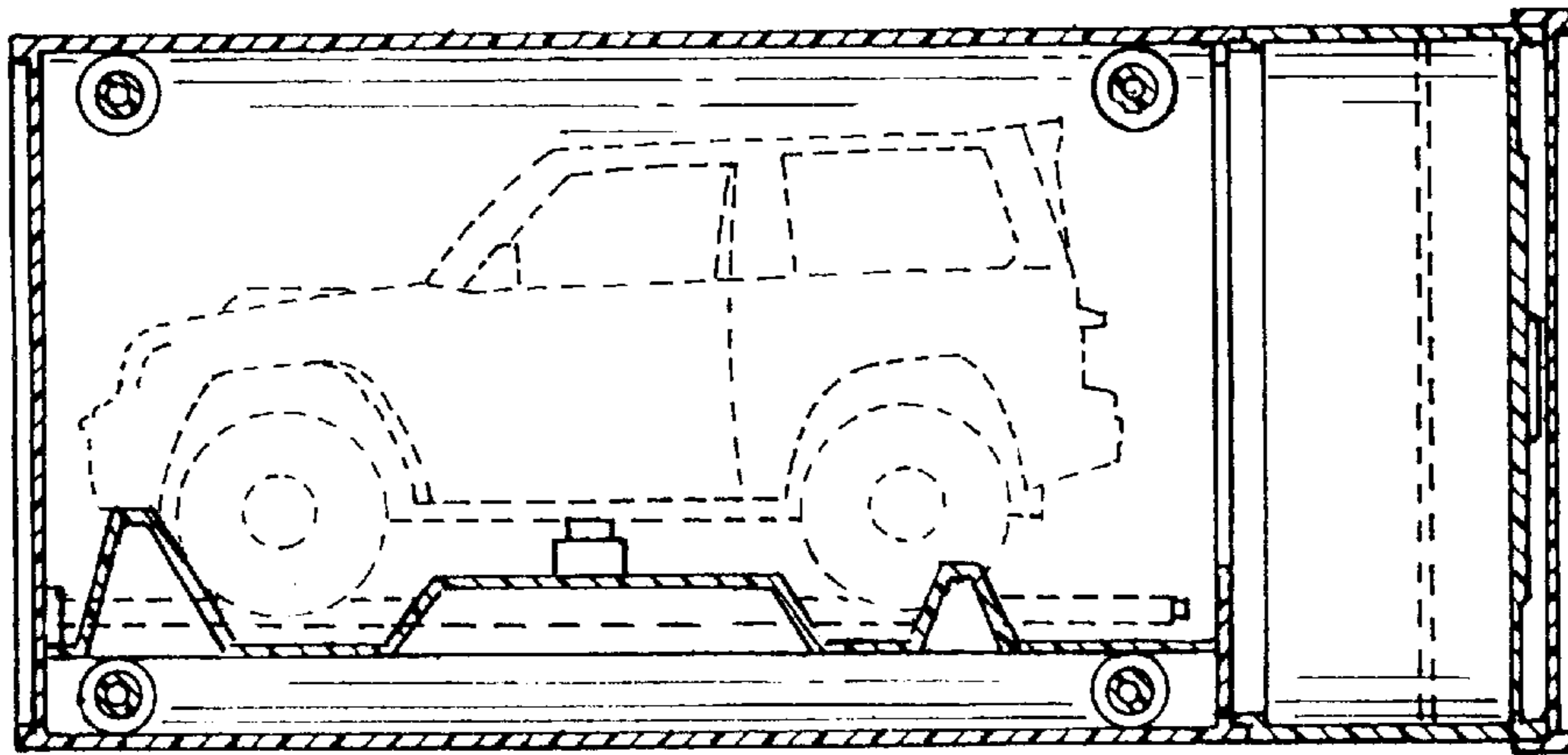

Fig. 6

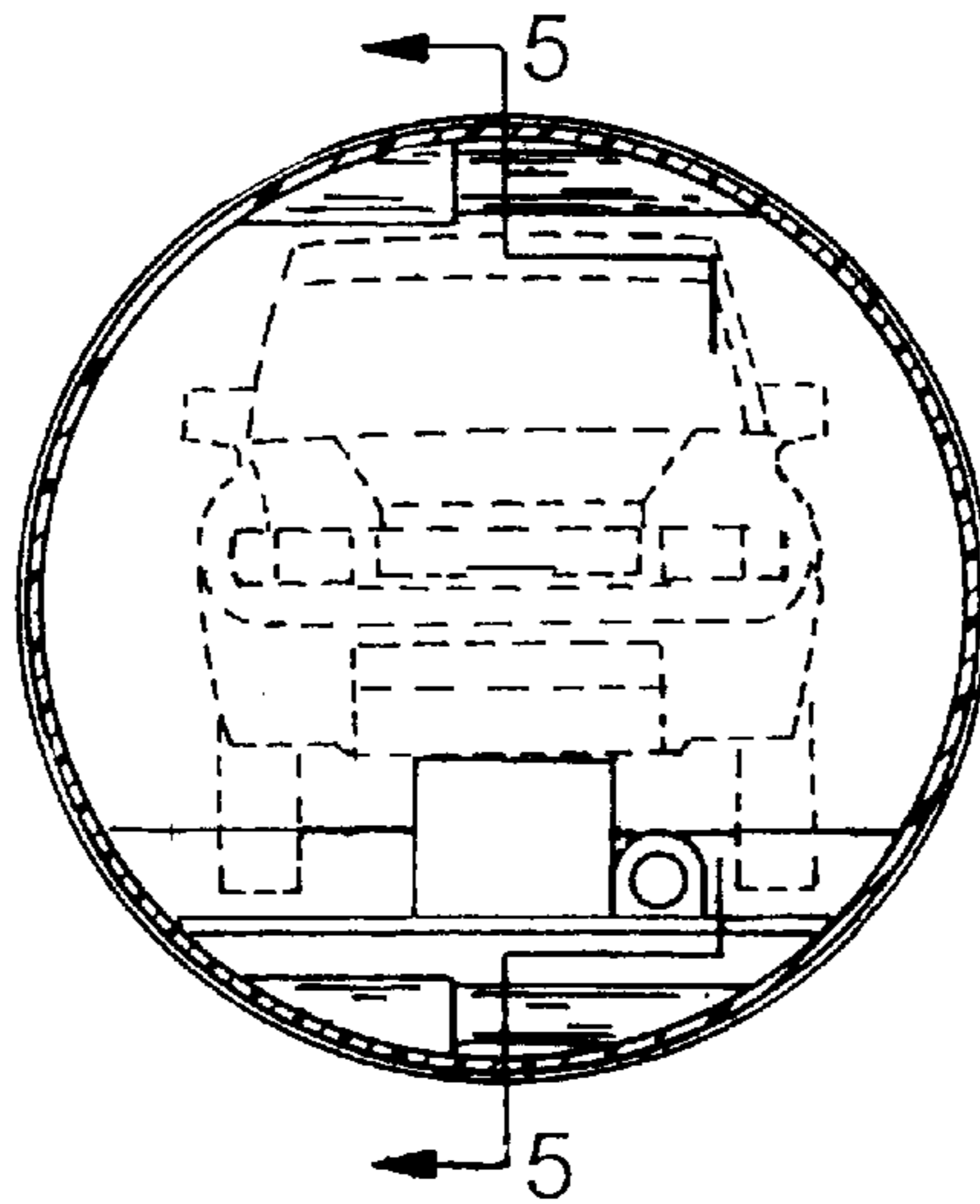
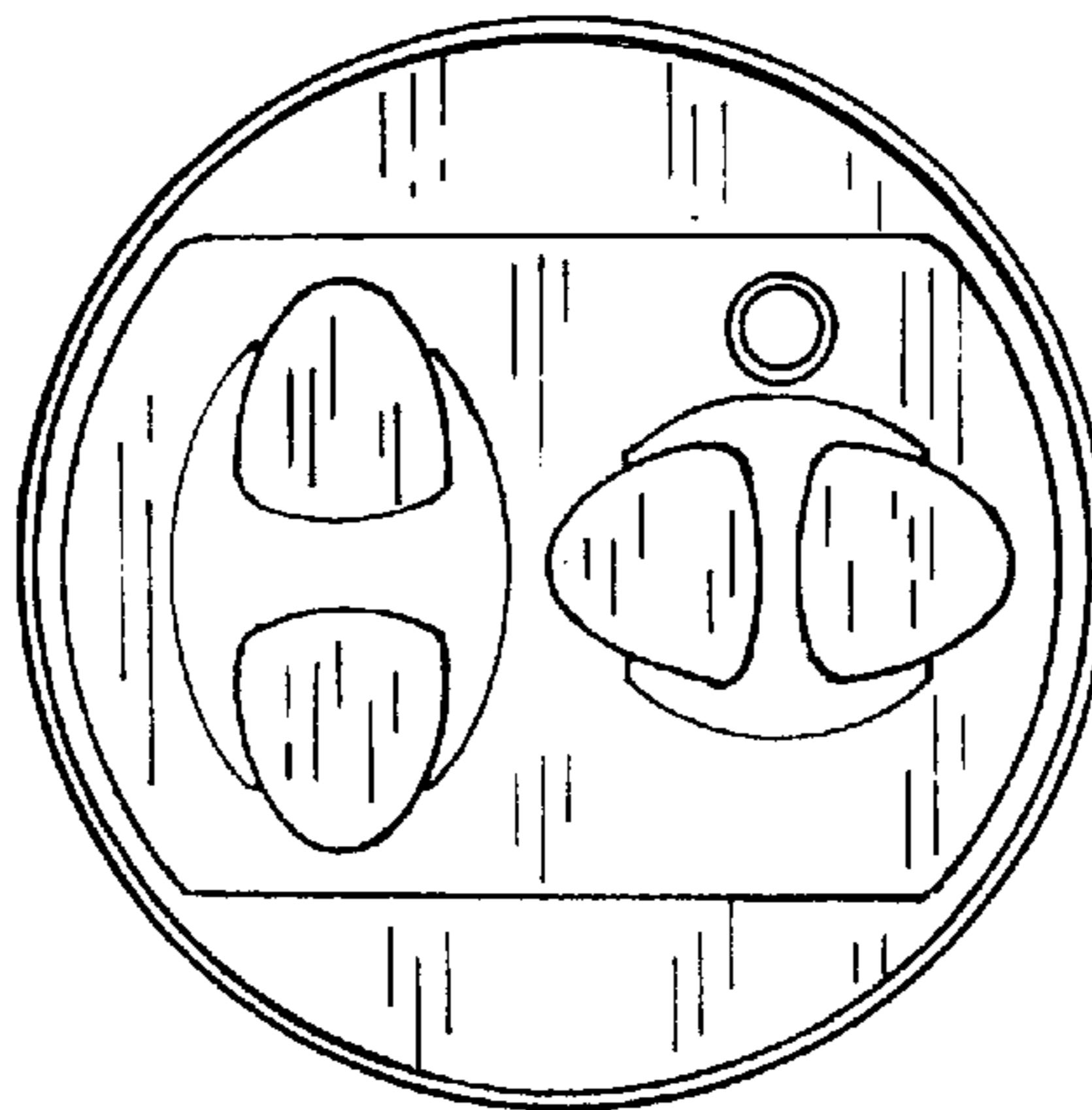

Fig. 8



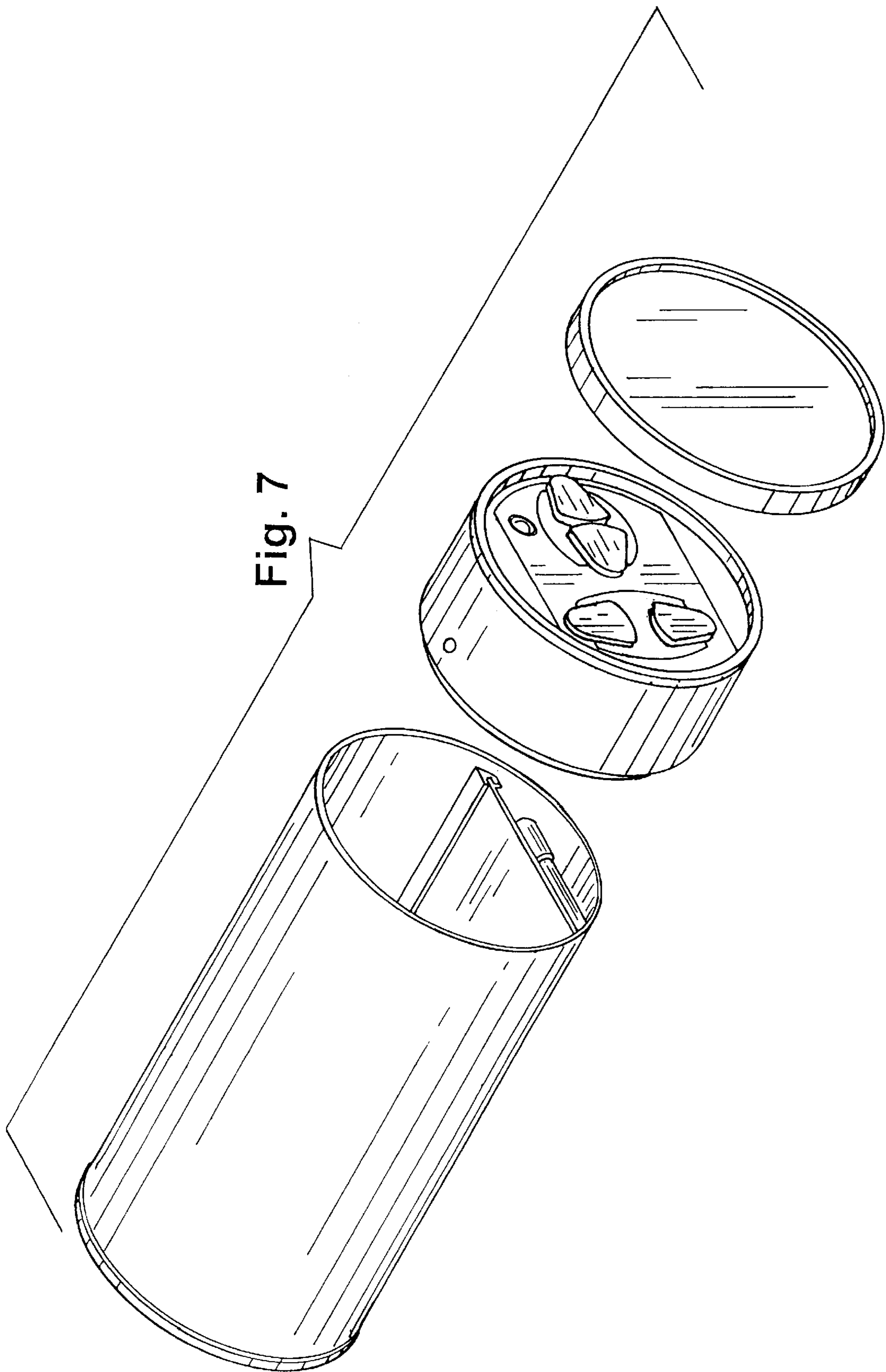

Fig. 7