



US00D424350S

# United States Patent [19]

Daansen

[11] Patent Number: Des. 424,350

[45] Date of Patent: \*\* May 9, 2000

[54] SOAP DISPENSER PUMP TIP

[76] Inventor: Warren S. Daansen, 39 Orange St., Nashua, N.H. 03060

[\*\*] Term: 14 Years

[21] Appl. No.: 29/107,291

[22] Filed: Jun. 30, 1999

[51] LOC (7) Cl. .... 23-02

[52] U.S. Cl. .... D6/542; D9/448

[58] Field of Search ..... D6/542-545; D9/448-449, D9/453-454, 439-442; 222/186-187, 189, 180

### [56] References Cited

#### U.S. PATENT DOCUMENTS

- D. 366,833 2/1996 Daansen .
- D. 370,813 6/1996 Daansen .
- D. 370,814 6/1996 Daansen .
- D. 371,514 7/1996 Daansen .
- D. 378,196 2/1997 Daansen .
- D. 378,718 4/1997 Daansen .
- D. 383,673 9/1997 Daansen .
- D. 383,674 9/1997 Daansen .
- D. 383,675 9/1997 Daansen .
- D. 385,193 10/1997 Daansen .
- D. 396,411 7/1998 Daansen .
- D. 396,589 8/1998 Daansen .

- 3,163,333 12/1964 Boyle et al. .... 222/180
- 4,625,896 12/1986 Rocchelli ..... 222/180
- 4,651,902 3/1987 Hobbs et al. .... 222/180
- 5,464,125 11/1995 Daansen .
- 5,501,372 3/1996 Daansen .

Primary Examiner—Brian N. Vinson  
Attorney, Agent, or Firm—Scott J. Asmus; Vernon C. Maine

### [57] CLAIM

The ornamental shape and design for a soap dispenser pump tip, as shown and described.

### DESCRIPTION

Applicant has disclosed a new, original and ornamental design, a soap dispenser pump tip, which is installed in soap dispensers that are typically wall-mounted in business and public restrooms and stocked with liquid hand detergent, liquid soaps compound, hand lotion, and similar compound, which is thereby available for use on demand. What the applicant claims as his design is substantially illustrated but without regard to choice of materials or dimensional particularity.

FIG. 1 is a front elevation perspective view of the pump tip showing my new design;

FIG. 2 is a rear elevation thereof;

FIG. 3 is a side elevation thereof;

FIG. 4 is a top plan thereof; and,

FIG. 5 is a bottom plan thereof.

1 Claim, 3 Drawing Sheets

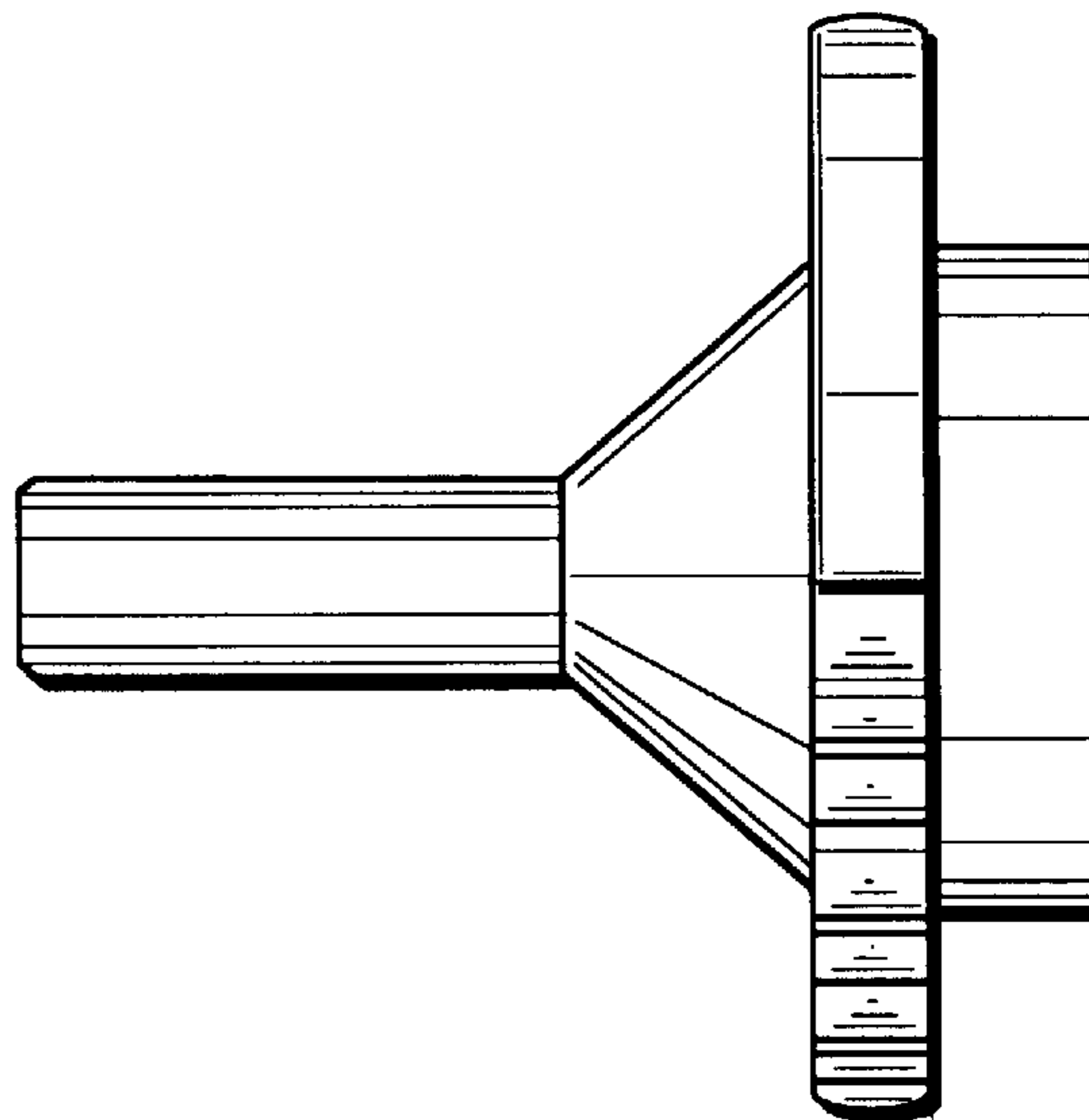
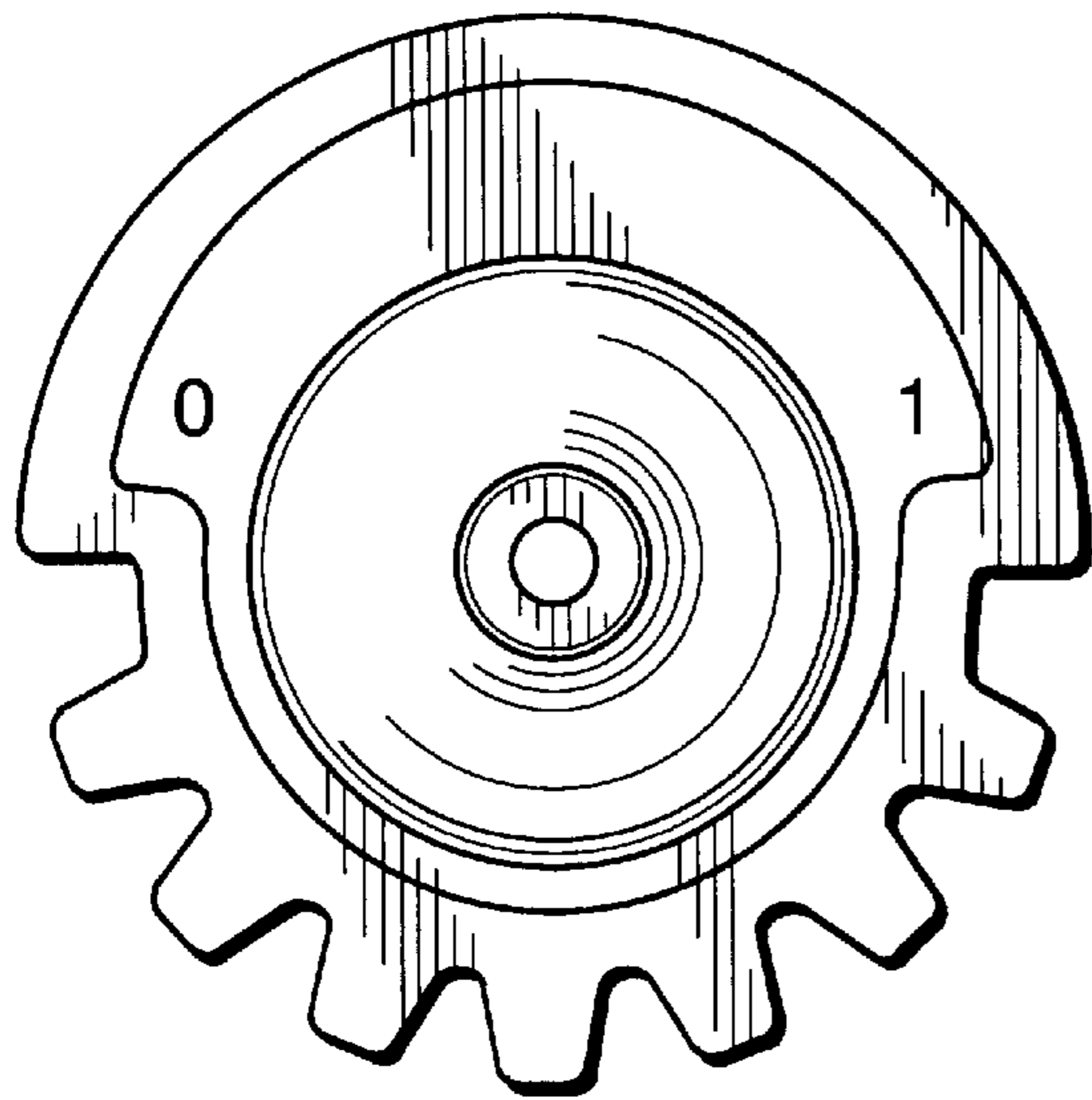

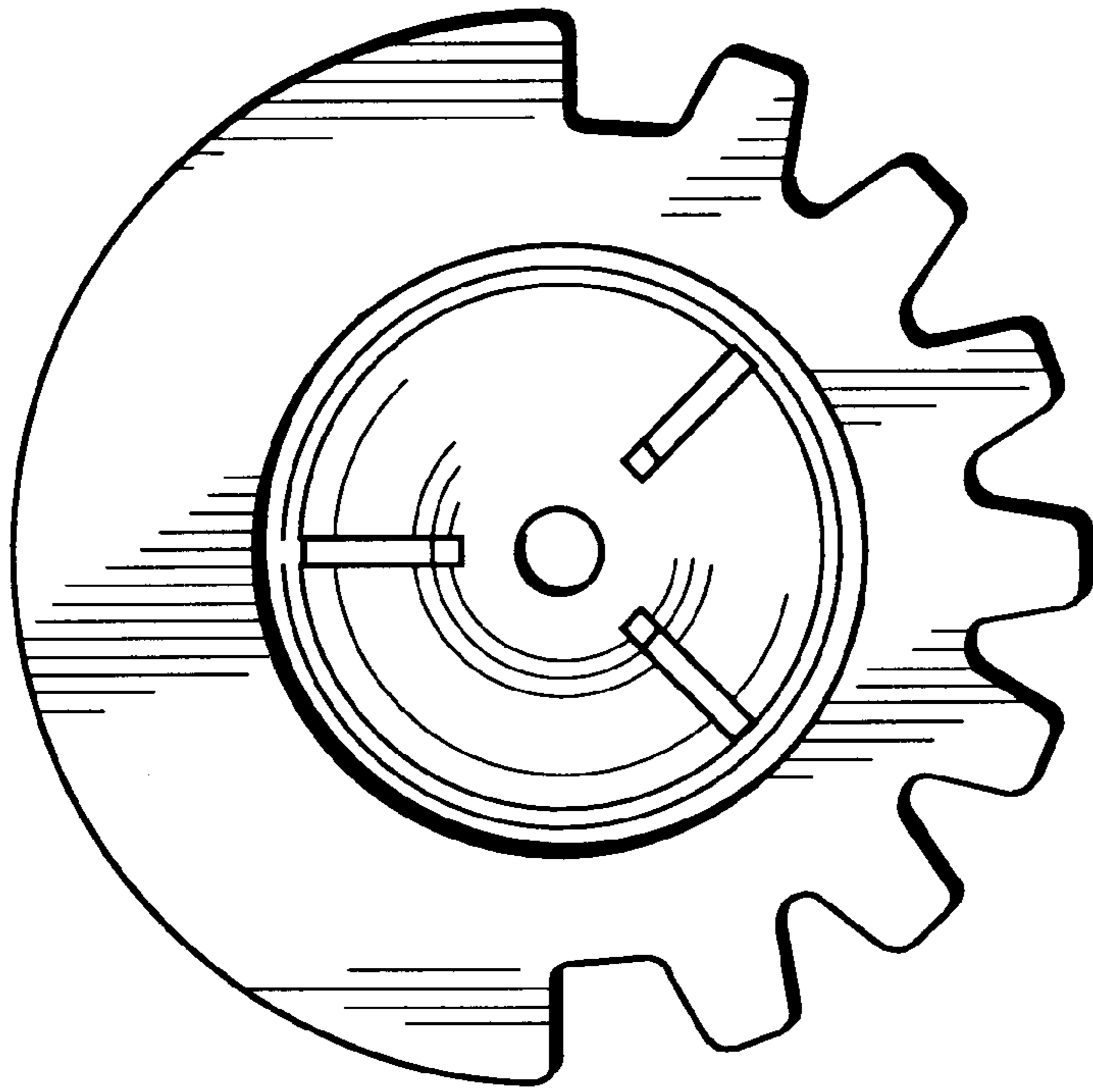

FIG. 2

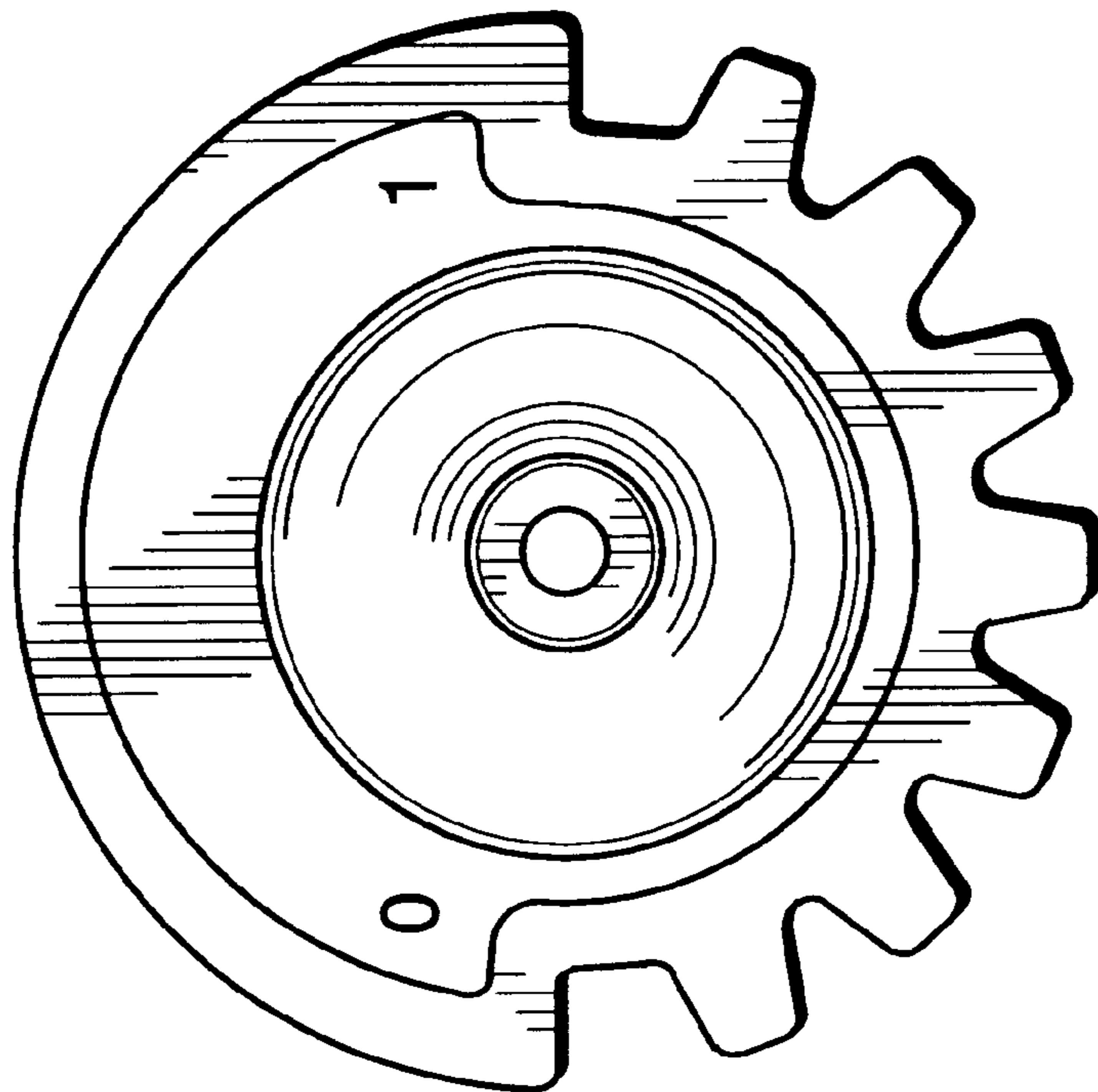

FIG. 1

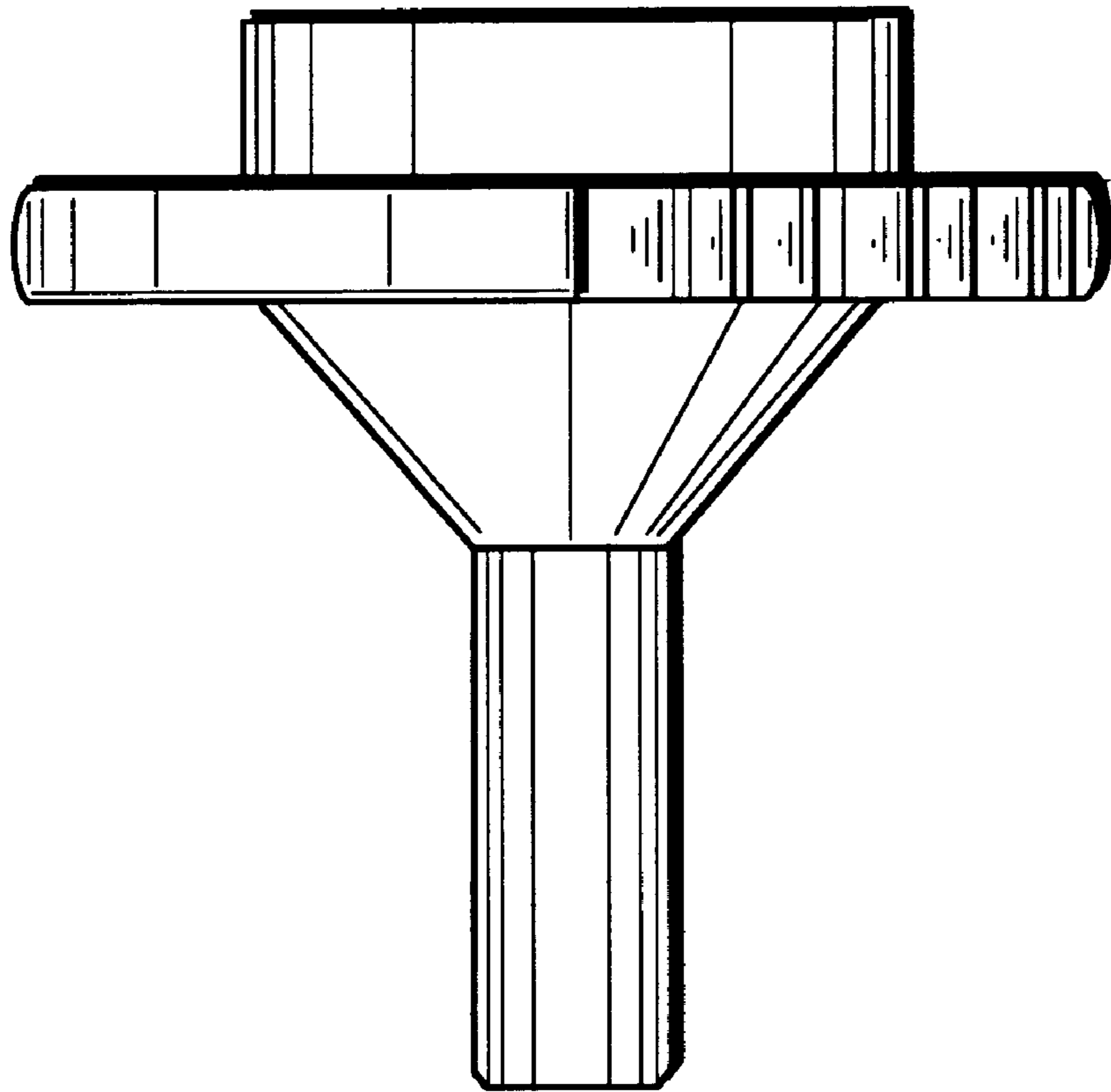

FIG. 3

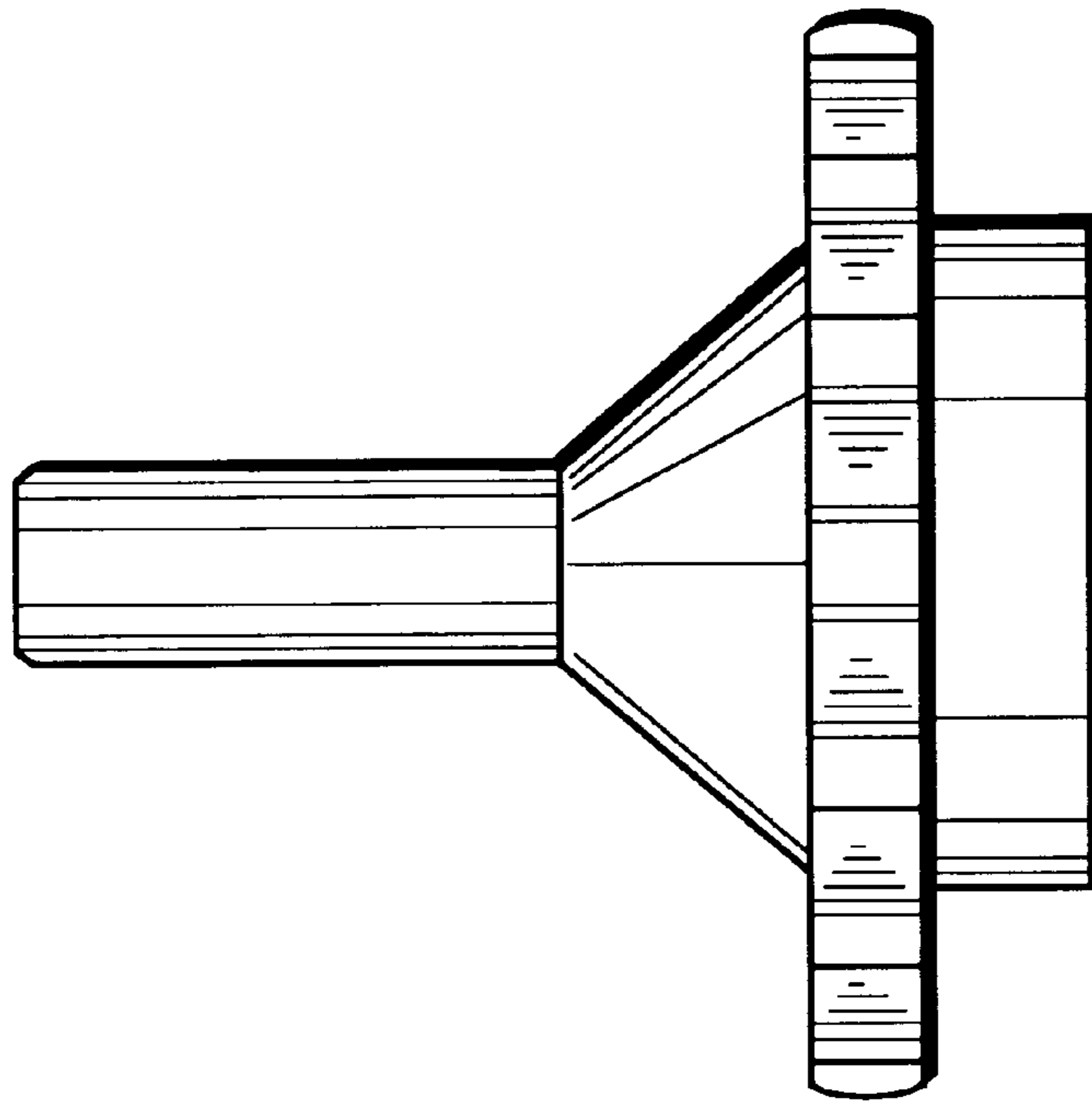

FIG. 5

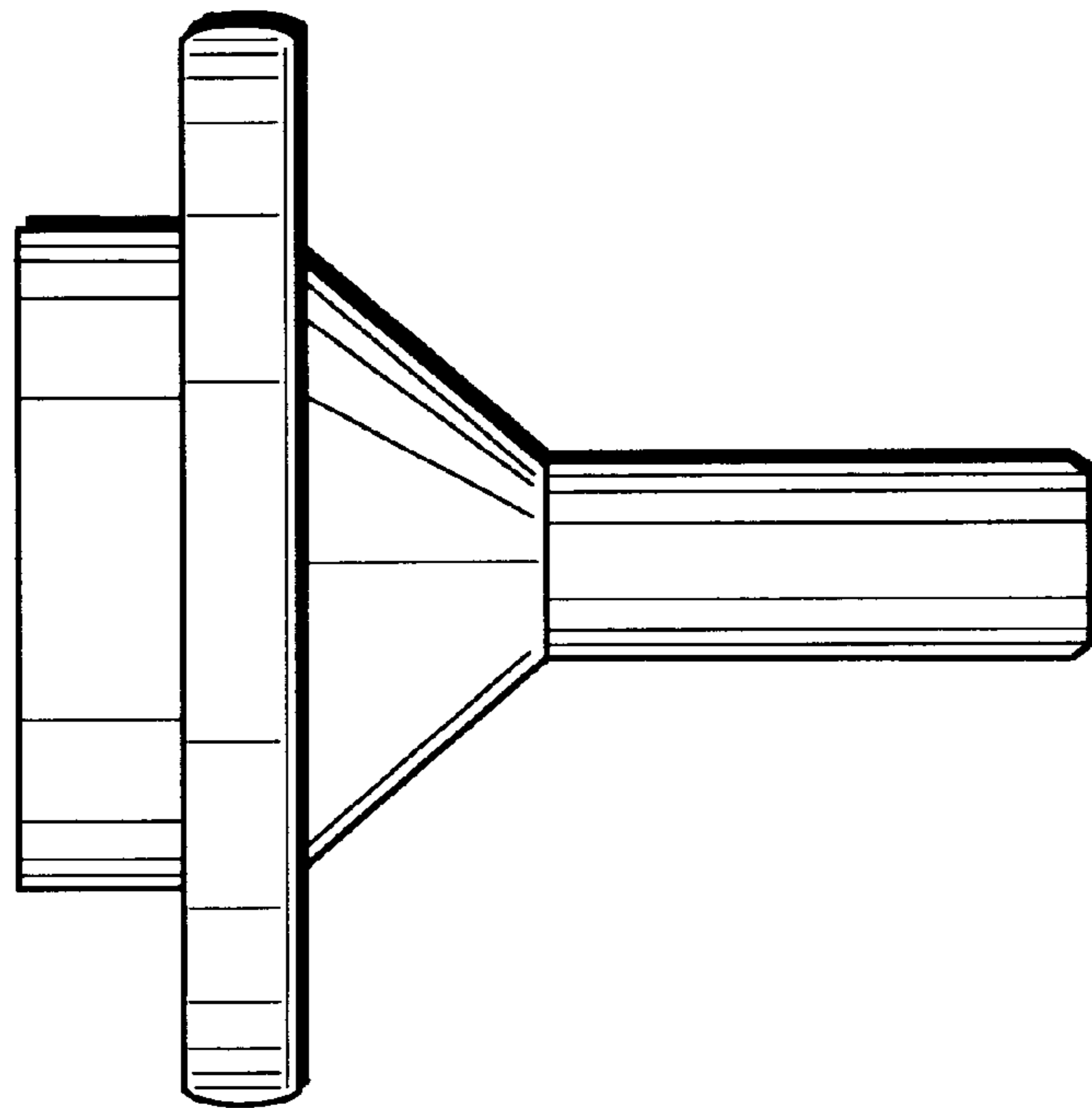

FIG. 4