



US00D424008S

# United States Patent [19] Montgomery

[11] **Patent Number: Des. 424,008**

[45] **Date of Patent: \*\* May 2, 2000**

[54] **MOTORIZED WATER SKI**

[76] Inventor: **Robert Eglinton Montgomery**, 34478  
Calle Carmelita, Dana Point, Calif.  
92624

[\*\*] Term: **14 Years**

[21] Appl. No.: **29/093,319**

[22] Filed: **Sep. 8, 1998**

[51] **LOC (7) Cl.** ..... **12-06**

[52] **U.S. Cl.** ..... **D12/307; D12/300**

[58] **Field of Search** ..... D12/300, 307;  
114/270; 440/38, 42, 46

[56] **References Cited**

**U.S. PATENT DOCUMENTS**

- D. 276,994 1/1985 Montgomery et al. .
- D. 334,552 4/1993 Montgomery et al. .
- D. 355,400 2/1995 Montgomery ..... D12/307
- 1,945,435 1/1934 Hopkins .
- 2,685,696 8/1954 Oscanyan .
- 2,812,736 11/1957 Fry .
- 3,262,413 7/1966 Douglas et al. .
- 3,324,822 6/1967 Carter, III .
- 3,340,845 9/1967 Tyrack .
- 3,369,518 2/1968 Jacobson .
- 3,371,646 3/1968 Mela .
- 3,406,653 10/1968 Mela .
- 3,463,116 8/1969 Dawson .
- 3,481,303 12/1969 Tate et al. .
- 3,548,778 12/1970 Von Smagala-Romanoff .
- 3,608,512 9/1971 Thompson .
- 3,828,717 8/1974 Nichols et al. .
- 3,882,815 5/1975 Bennett .

- 3,911,846 10/1975 England .
- 4,274,357 6/1981 Dawson .
- 4,350,116 9/1982 Moreau et al. .
- 4,402,674 9/1983 Roberts .
- 4,538,996 9/1985 Inwood .
- 4,628,852 12/1986 Nishida et al. .
- 4,857,025 8/1989 Brown et al. .
- 5,167,550 12/1992 Nielsen .
- 5,385,494 1/1995 Wilhelmi .

**FOREIGN PATENT DOCUMENTS**

- 0 575 130 A1 12/1993 European Pat. Off. .
- 2 617 793 7/1987 France .

**OTHER PUBLICATIONS**

Nina Morgan, Marine Technology Handbook, 1990, pp. 3/80 & 3/81.

*Primary Examiner*—Kay H. Chin  
*Attorney, Agent, or Firm*—Lynn & Lynn

[57] **CLAIM**

I claim the ornamental design for a motorized water ski, as shown and described.

**DESCRIPTION**

FIG. 1 is a perspective view of a motorized water ski showing my new design;  
FIG. 2 top plan view thereof;  
FIG. 3 is a front elevation view thereof  
FIG. 4 is a right side elevation view thereof;  
FIG. 5 is a rear perspective view thereof; and  
FIG. 6 is a bottom plan view thereof; and,  
FIG. 7 is a rear elevation view thereof.

**1 Claim, 4 Drawing Sheets**

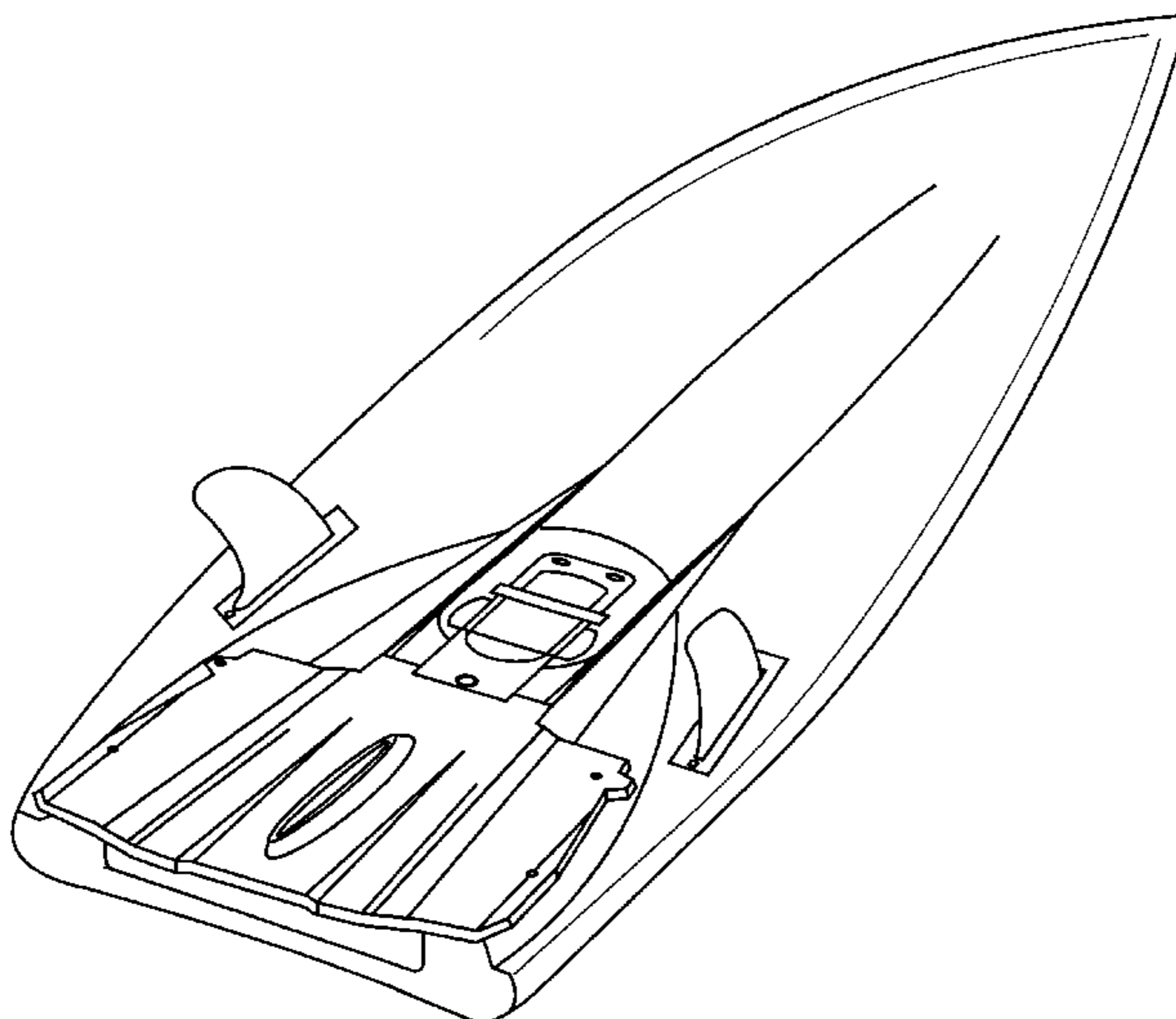
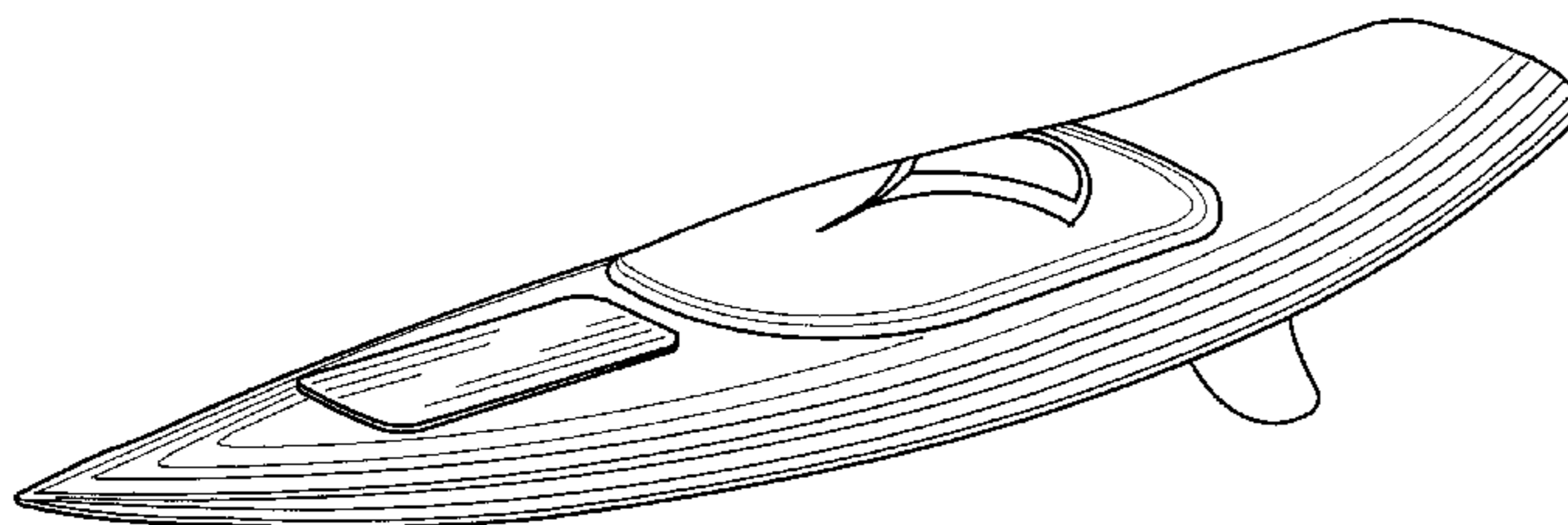

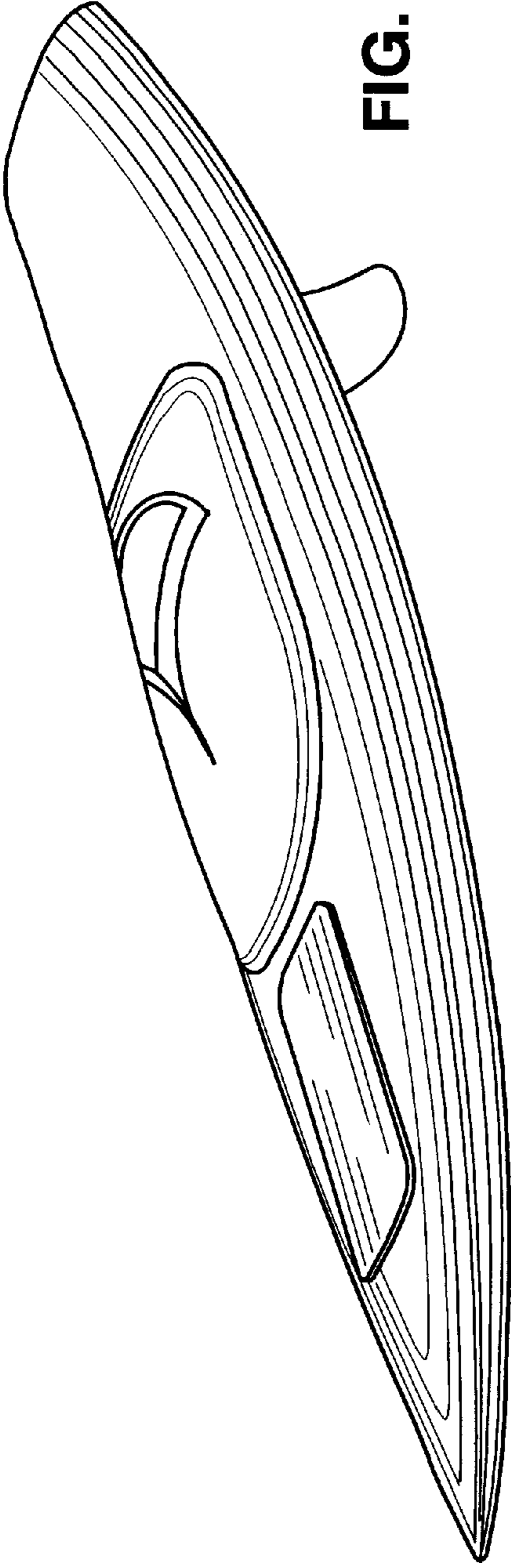

FIG. 1

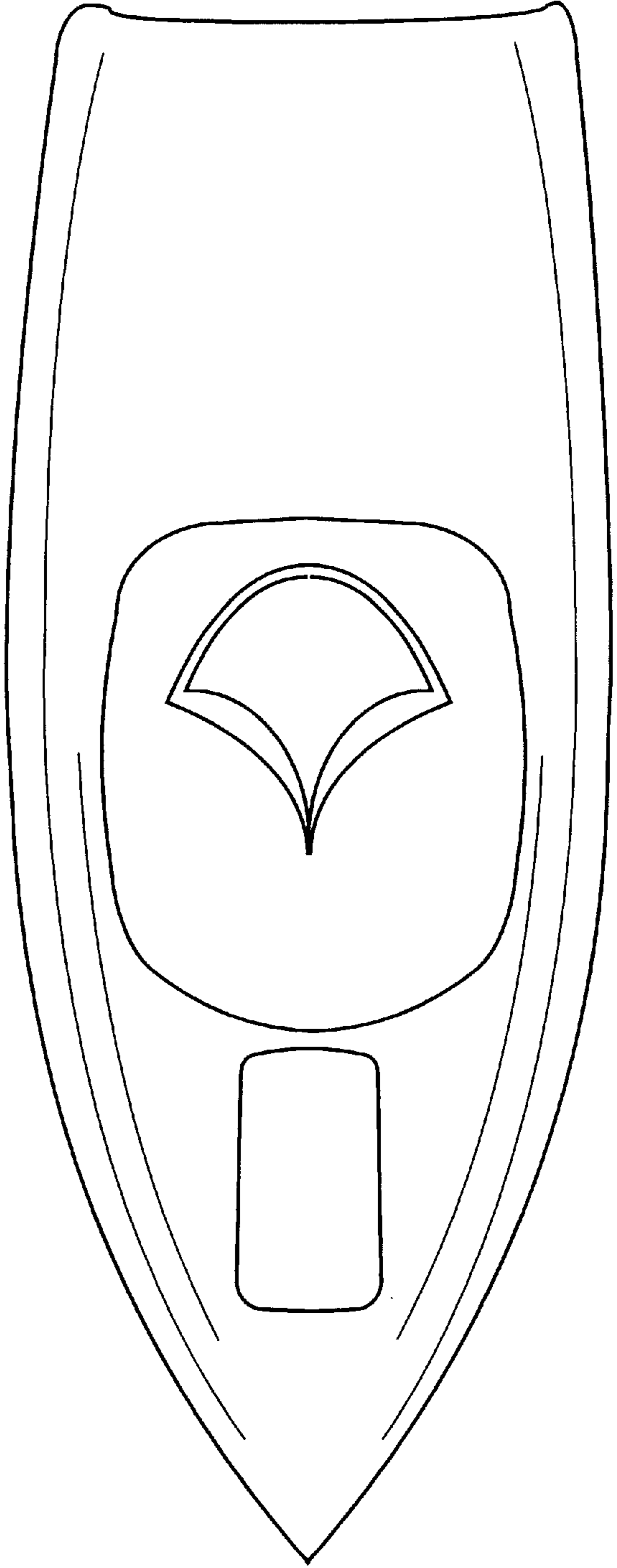
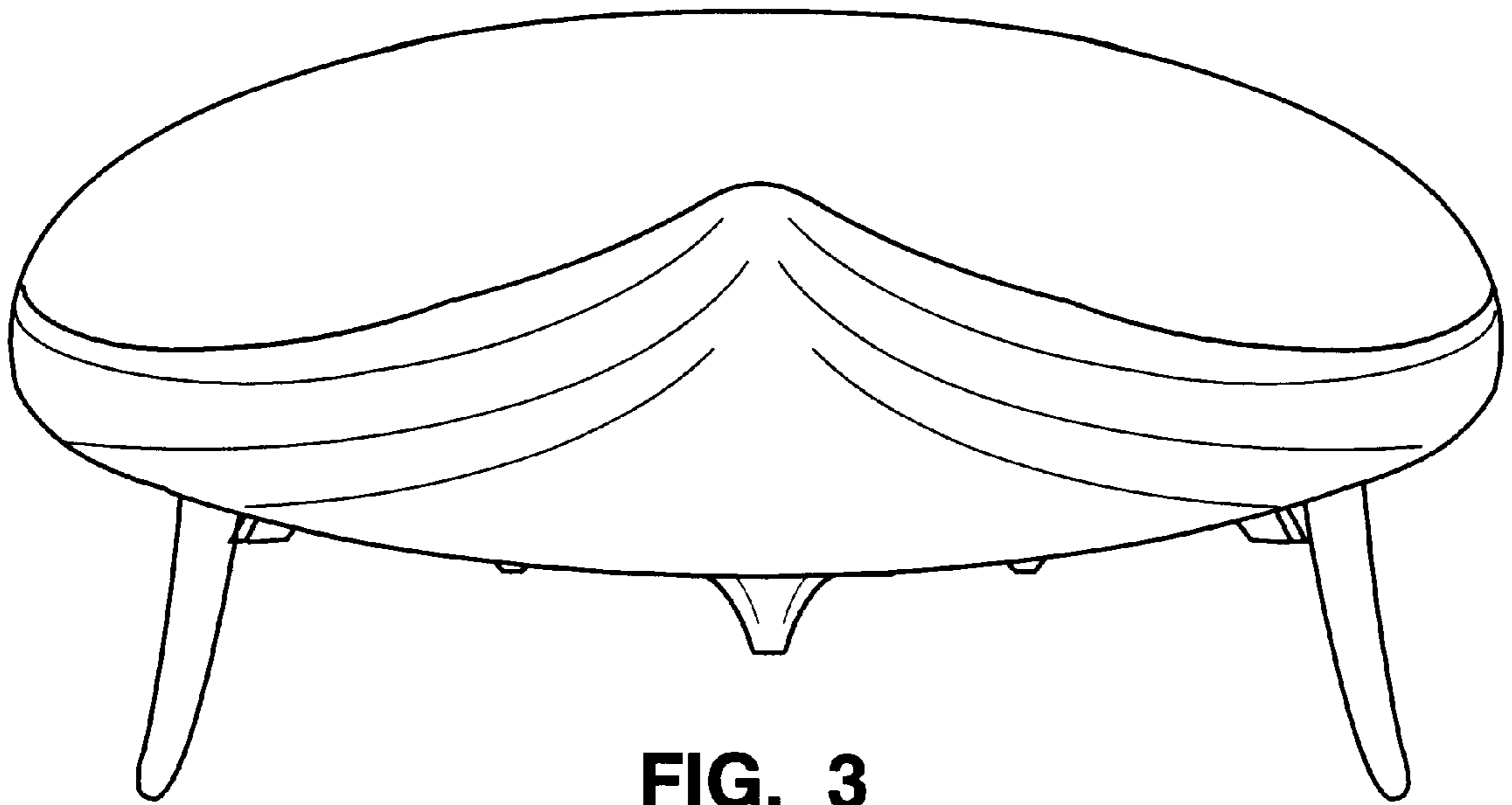
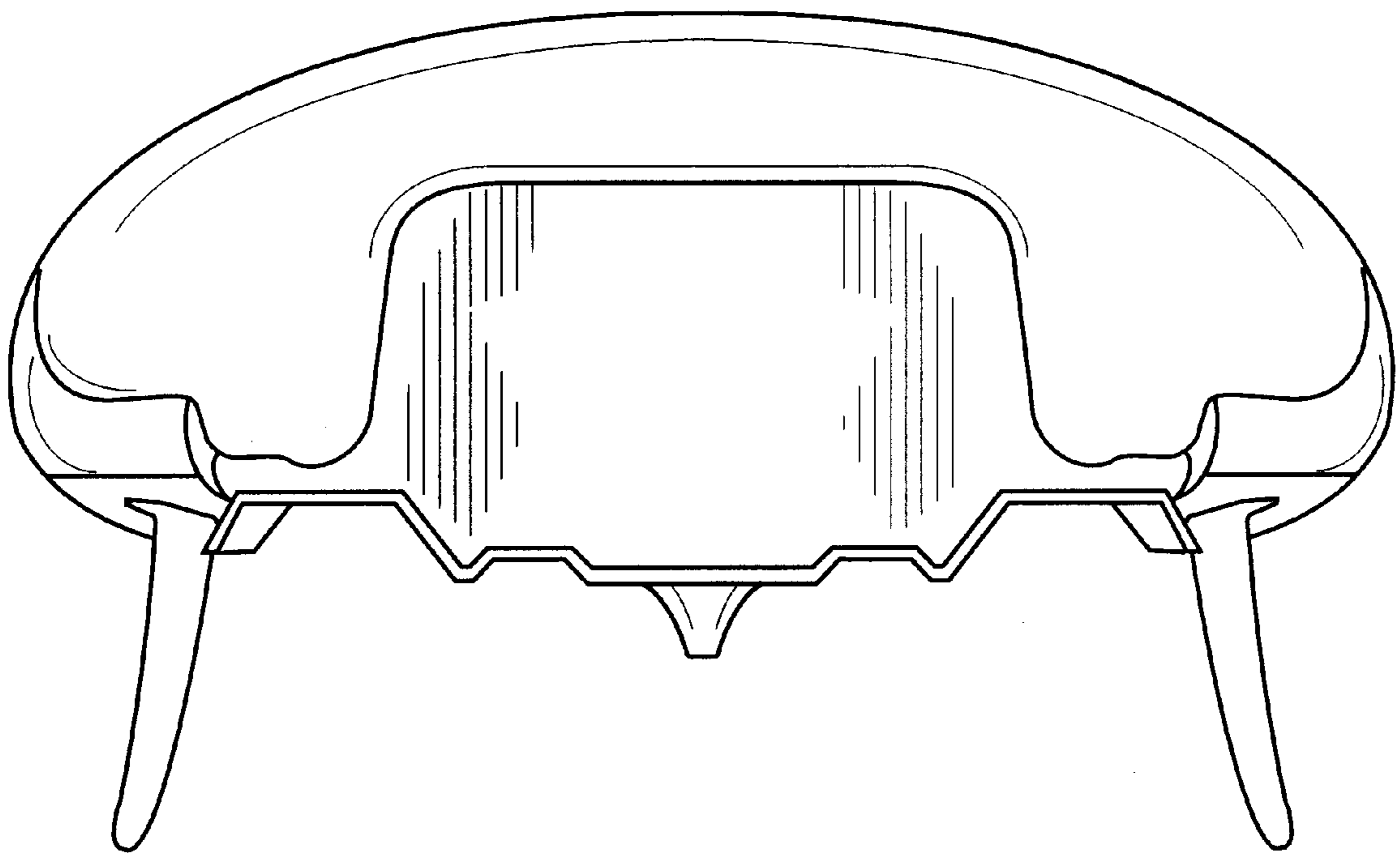

FIG. 2



**FIG. 3**



**FIG. 7**

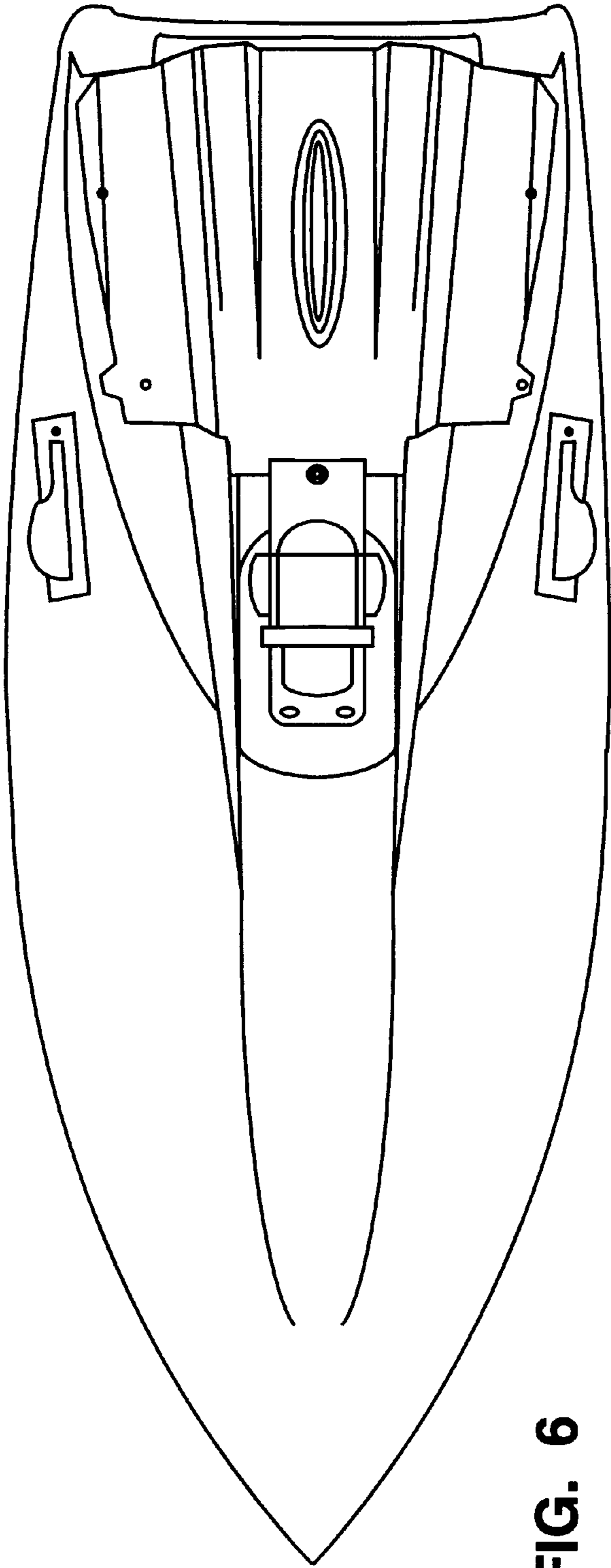

FIG. 6

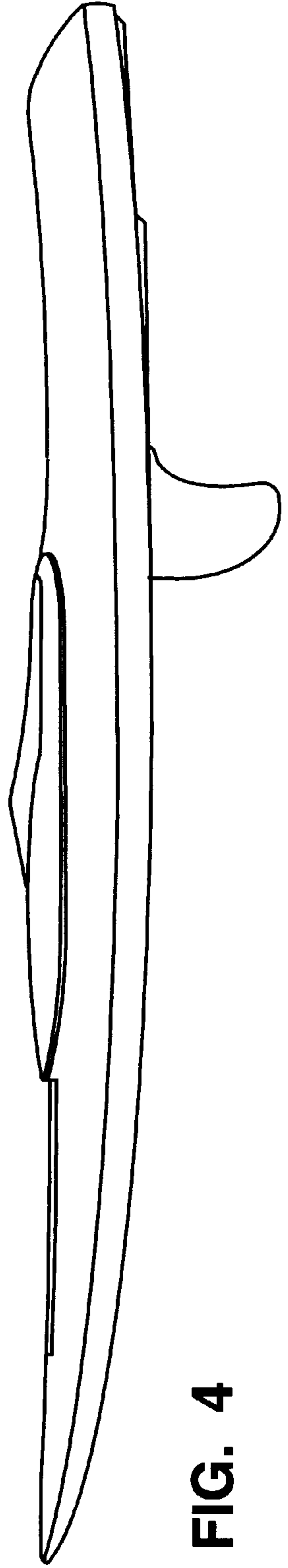

FIG. 4

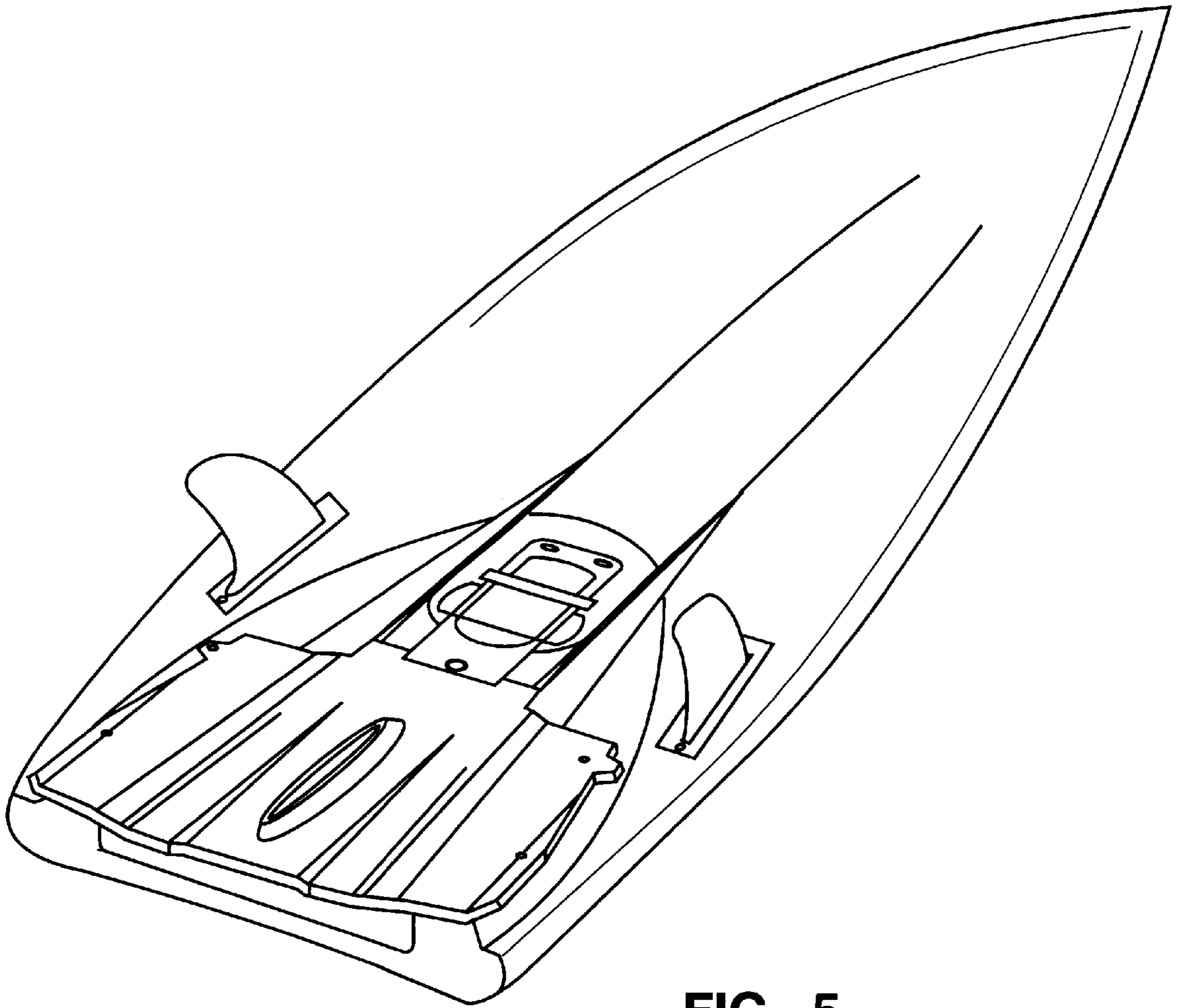

FIG. 5