



US00D423990S

# United States Patent [19]

[11] Patent Number: Des. 423,990

Meryman et al.

[45] Date of Patent: \*\* May 2, 2000

## [54] TRUCK BODY

[75] Inventors: Roy L. Meryman, Renton; Wayne K. Simons, Kent, both of Wash.

[73] Assignee: PACCAR Inc, Bellevue, Wash.

[\*\*] Term: 14 Years

[21] Appl. No.: 29/106,666

[22] Filed: Jun. 18, 1999

### Related U.S. Application Data

[62] Division of application No. 29/053,898, May 1, 1996, Pat. No. Des. 411,140.

[51] LOC (7) Cl. .... 12-08

[52] U.S. Cl. .... D12/96

[58] Field of Search ..... D12/96, 97; 296/190, 296/181; 180/89.1, 89.11, 89.12, 89.14, 89.16

### References Cited

#### U.S. PATENT DOCUMENTS

D. 312,805	12/1990	Marlowe et al. .	
D. 320,583	10/1991	Simons et al. .	
D. 328,273	7/1992	Kerney et al. .	
D. 366,638	1/1996	Tucker et al. .	
D. 394,026	5/1998	Hellhake et al. ....	D12/96
D. 399,791	10/1998	Hellhake et al. ....	D12/96
D. 399,792	10/1998	Hellhake et al. ....	D12/96
D. 403,636	1/1999	Meryman et al. ....	D12/169
D. 406,553	3/1999	Hellhake et al. ....	D12/96
D. 411,140	6/1999	Meryman et al. ....	D12/96
5,308,134	5/1994	Stanesu .	

#### OTHER PUBLICATIONS

- “Kenworth The World’s Best”, Kenworth Truck Company brochure, Kirkland, WA.
- “Kenworth: Historical Background”, Kenworth Truck Company brochure, Kirkland, WA.
- “Kenworth K100E”, Canadian Kenworth Truck Company brochure, Mississauga, Ontario.
- “Kenworth T300”, Kenworth Truck Company brochure, Kirkland, WA.

- “Kenworth T400B T450B”, Kenworth Truck Company brochure, Kirkland, WA.
- “Kenworth C500B The Ultimate Survivor”, Kenworth Truck Company brochure, Kirkland, WA.
- “Kenworth’s T600: Ten Years of Innovation”, Kenworth Truck Company brochure, Kirkland, WA (Jun. 1995).
- “Kenworth T600”, Kenworth Truck Company brochure, Kirkland, WA.
- “Kenworth T600A, The Conventional Made Extraordinary”, Kenworth Truck Company Brochure, Kirkland, WA.
- “Kenworth T800”, Kenworth Truck Company brochure, Kirkland, WA.
- “Kenworth T800B”, Kenworth Truck Company brochure, Kirkland, WA.
- “Kenworth W900”, Kenworth Truck Company brochure, Kirkland, WA.
- “Kenworth W900L Aerocab”, Kenworth Truck Company brochure, Kirkland, WA.
- “Kenworth Construction Trucks”, Canadian Kenworth Truck Company brochure, Mississauga, Ontario.
- “Kenworth Aerocab”, Kenworth Truck Company brochure, Kirkland, WA.
- “Last Year, One Idea Changed A Lot of Attitudes About Driver Retention—Aerocab”, Kenworth Truck Company brochure, Kirkland, WA.
- “Kenworth Studio Sleeper”, Kenworth Truck Company brochure, Kirkland, WA.

Primary Examiner—Melody N. Brown  
Attorney, Agent, or Firm—Wells, St. John, Roberts, Gregory & Matkin, P.S.

### [57] CLAIM

We claim the ornamental design for a truck body, as shown and described.

### DESCRIPTION

FIG. 1 is a side elevational view of a truck body showing my new design, the opposite side view is a mirror image of that side shown;  
 FIG. 2 is a top plan view thereof;  
 FIG. 3 is a front elevational view thereof; and,  
 FIG. 4 is a rear elevational view thereof.  
 The truck portions shown in broken lines are for illustrative purposes only and form no part of the claimed design.

1 Claim, 4 Drawing Sheets

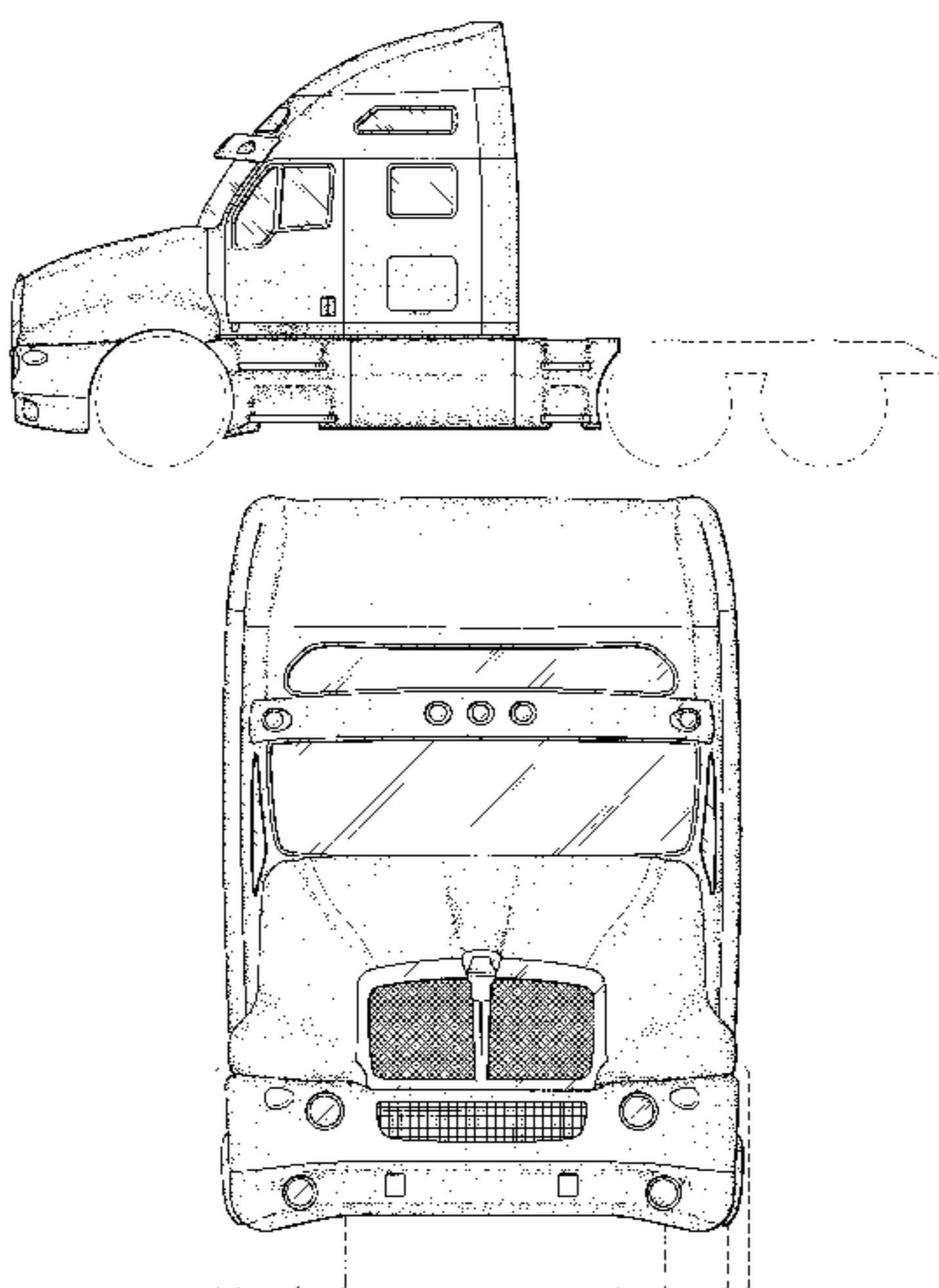

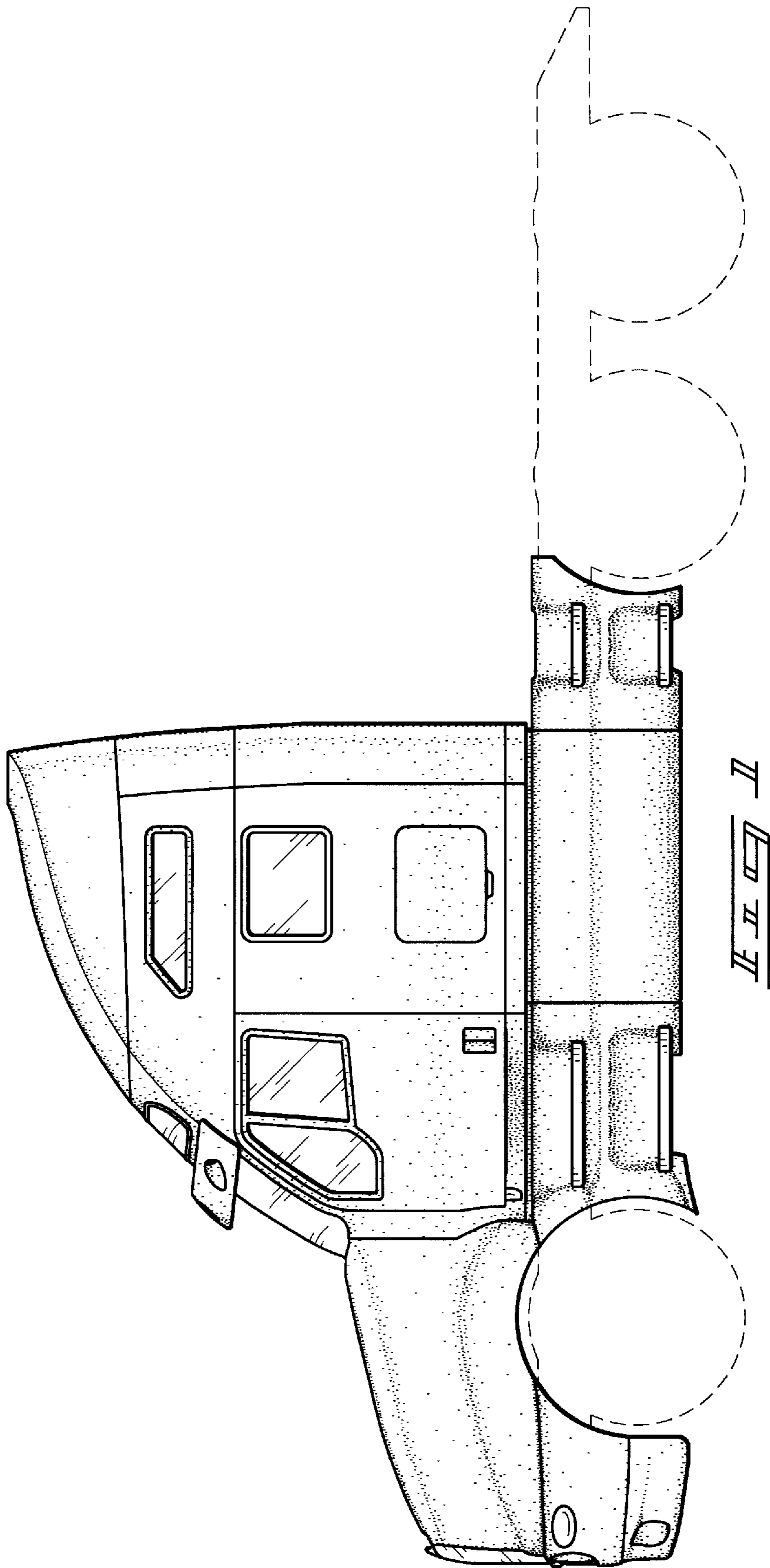

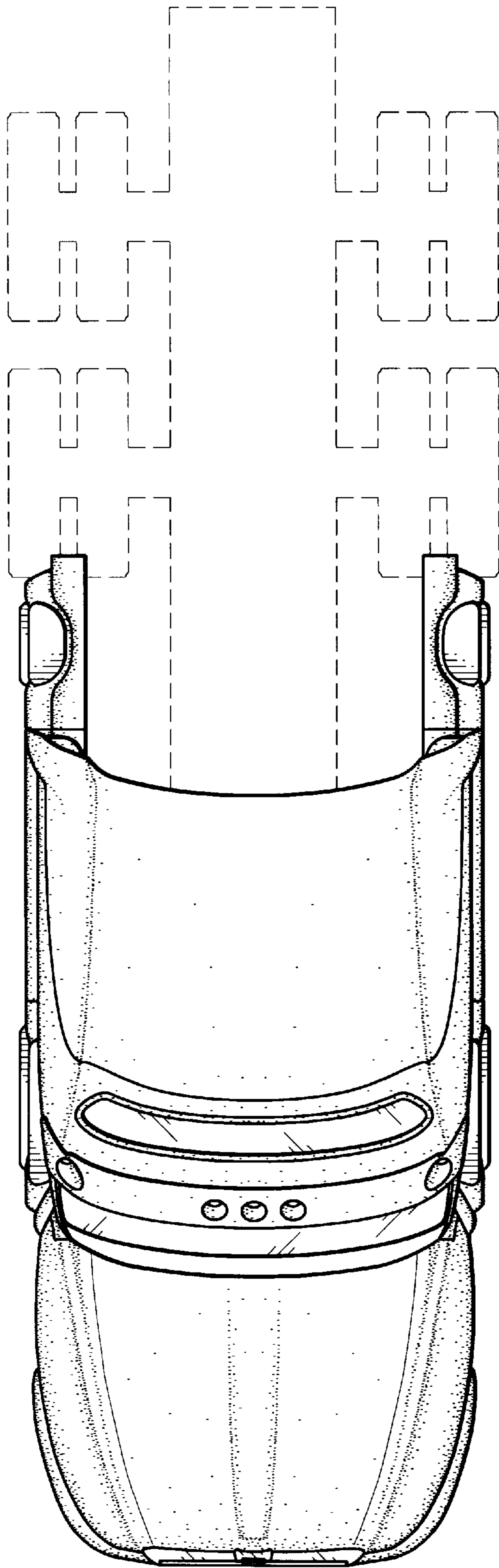
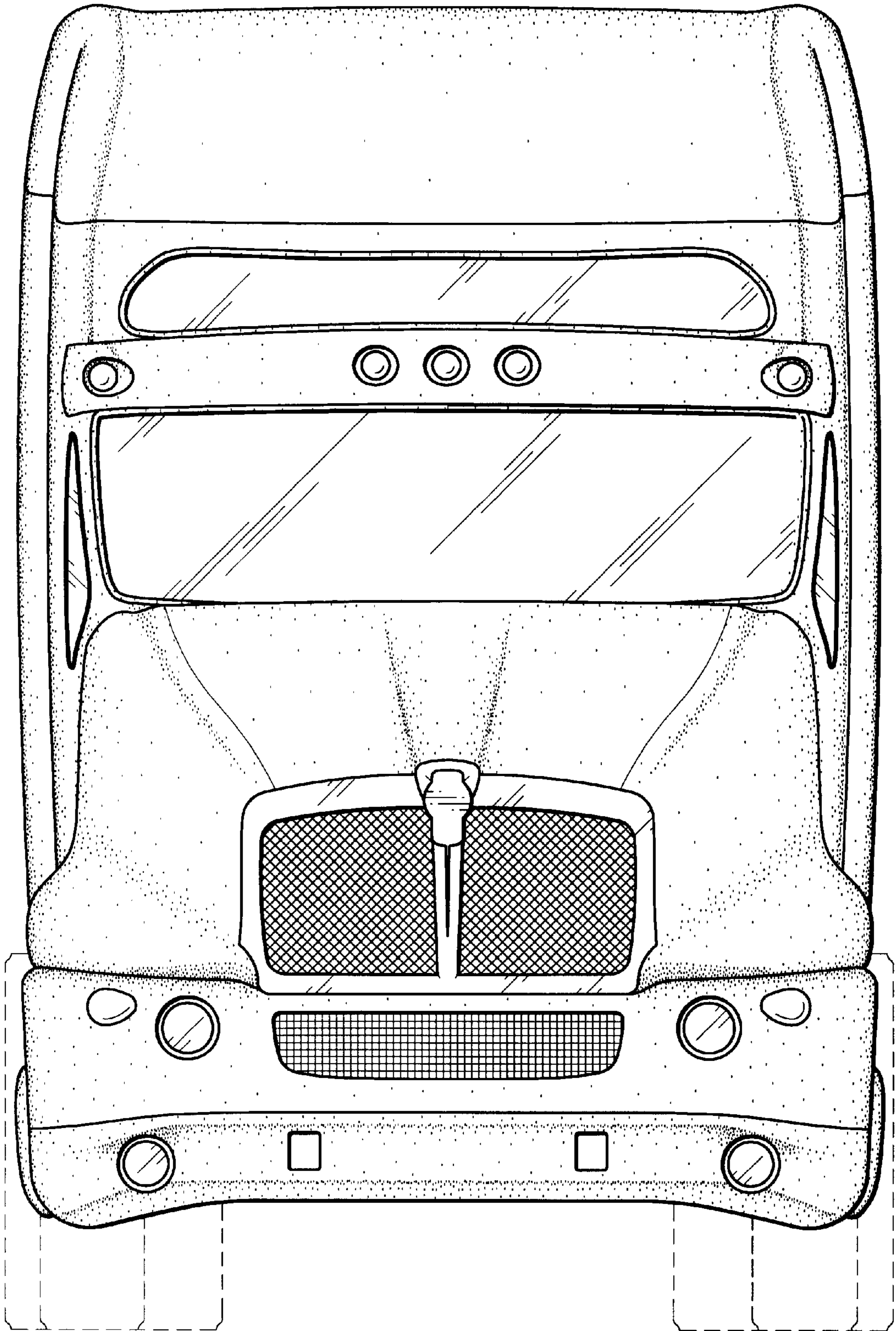

FIG. 2



*Fig. 3*

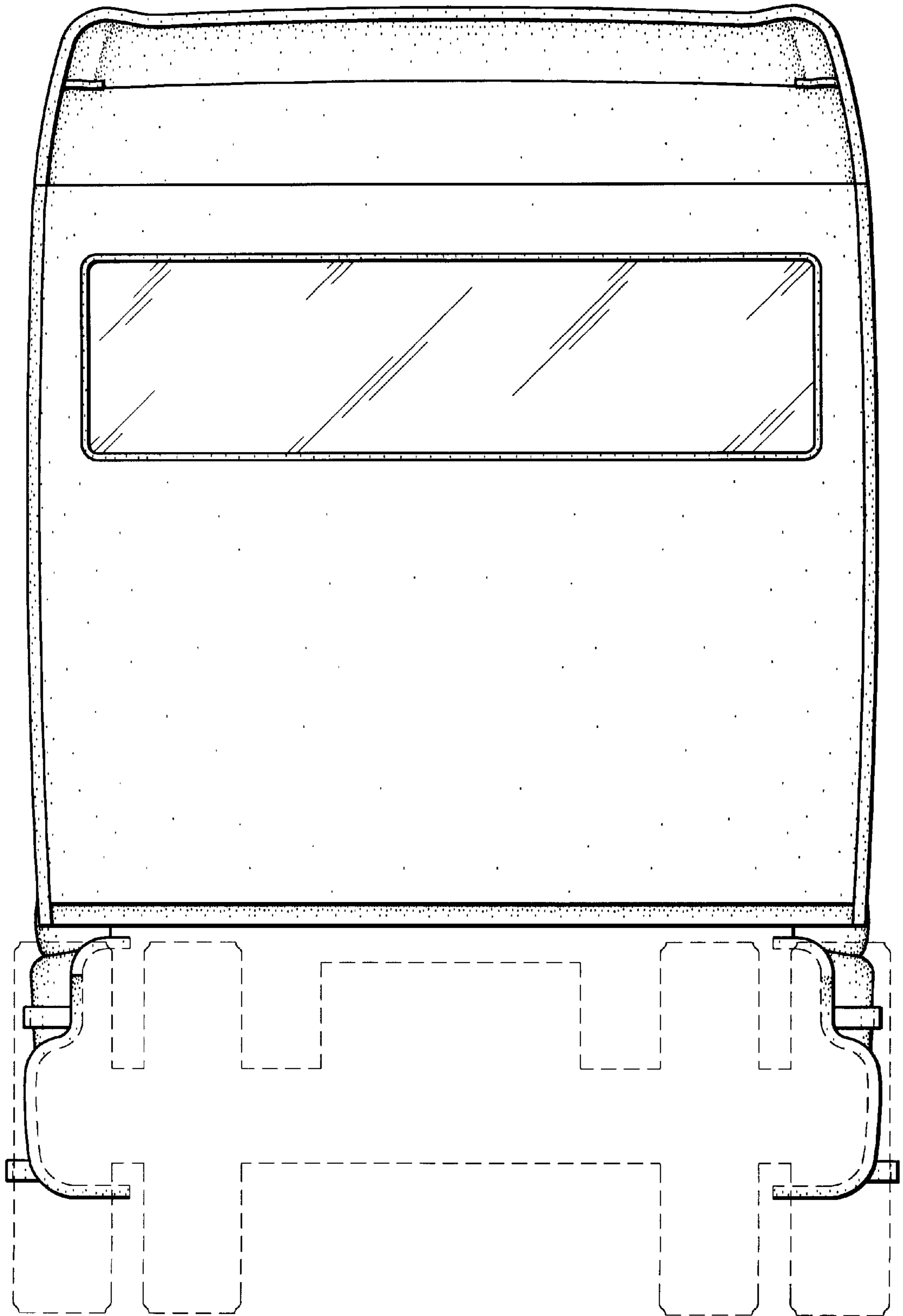

FIG. 4