



US00D423429S

United States Patent [19]
Hickman et al.

[11] **Patent Number: Des. 423,429**

[45] **Date of Patent: ** Apr. 25, 2000**

[54] **BUMPER END FOR A TRUCK**
[75] Inventors: **John T. Hickman**, Sanger; **David A. Neves**; **Thomas D. Reed, Jr.**, both of Denton, all of Tex.
[73] Assignee: **Paccar Inc**, Bellevue, Wash.
[**] Term: **14 Years**
[21] Appl. No.: **29/101,615**
[22] Filed: **Mar. 8, 1999**
[51] **LOC (6) Cl.** **12-16**
[52] **U.S. Cl.** **D12/169**
[58] **Field of Search** D12/169, 172, D12/96; 293/102, 113, 115, 120; 296/180.1, 180.2

5,499,690 3/1996 Shearn et al. 180/68.4

Primary Examiner—Melody N. Brown
Attorney, Agent, or Firm—Sidley & Austin

[57] **CLAIM**

The ornamental design for a bumper end for a truck, as shown and described.

DESCRIPTION

FIG. 1 is a perspective view of a bumper end for a truck showing our new design;
FIG. 2 is a front view thereof;
FIG. 3 is a right view thereof;
FIG. 4 is a back view thereof;
FIG. 5 is a left side view thereof;
FIG. 6 is a top view thereof;
FIG. 7 is a bottom view thereof;
FIG. 8 is a perspective view of a second embodiment of our invention;
FIG. 9 is a front view of FIG. 8;
FIG. 10 is a left view of FIG. 8;
FIG. 11 is a back view of FIG. 8;
FIG. 12 is a right side view of FIG. 8;
FIG. 13 is a top view of FIG. 8;
FIG. 14 is a bottom view of FIG. 8; and,
FIG. 15 is a reduced perspective view of the first and second embodiments showing the environment in which they can be used.
The broken line showing of a partial automobile, in FIG. 15, is for illustrative purposes only and forms no part of the claimed design.

[56] **References Cited**

U.S. PATENT DOCUMENTS

D. 304,569	11/1989	Brunger et al.	D12/172
D. 307,254	4/1990	Koske et al.	D12/169
D. 316,241	4/1991	Ray	D12/169
D. 316,698	5/1991	Hensley et al.	D12/172
D. 335,272	5/1993	Allendorph et al.	D12/173
D. 343,605	1/1994	Meryman	D12/169
D. 354,264	1/1995	McCoy	D12/167
D. 364,371	11/1995	Ray et al.	D12/169
D. 367,027	2/1996	Onopa	D12/173
D. 381,946	8/1997	Delashaw et al.	D12/167
D. 391,212	2/1998	Meryman et al.	D12/169
D. 403,636	1/1999	Meryman et al.	D12/173
4,972,913	11/1990	Ray et al.	180/69.21

1 Claim, 3 Drawing Sheets

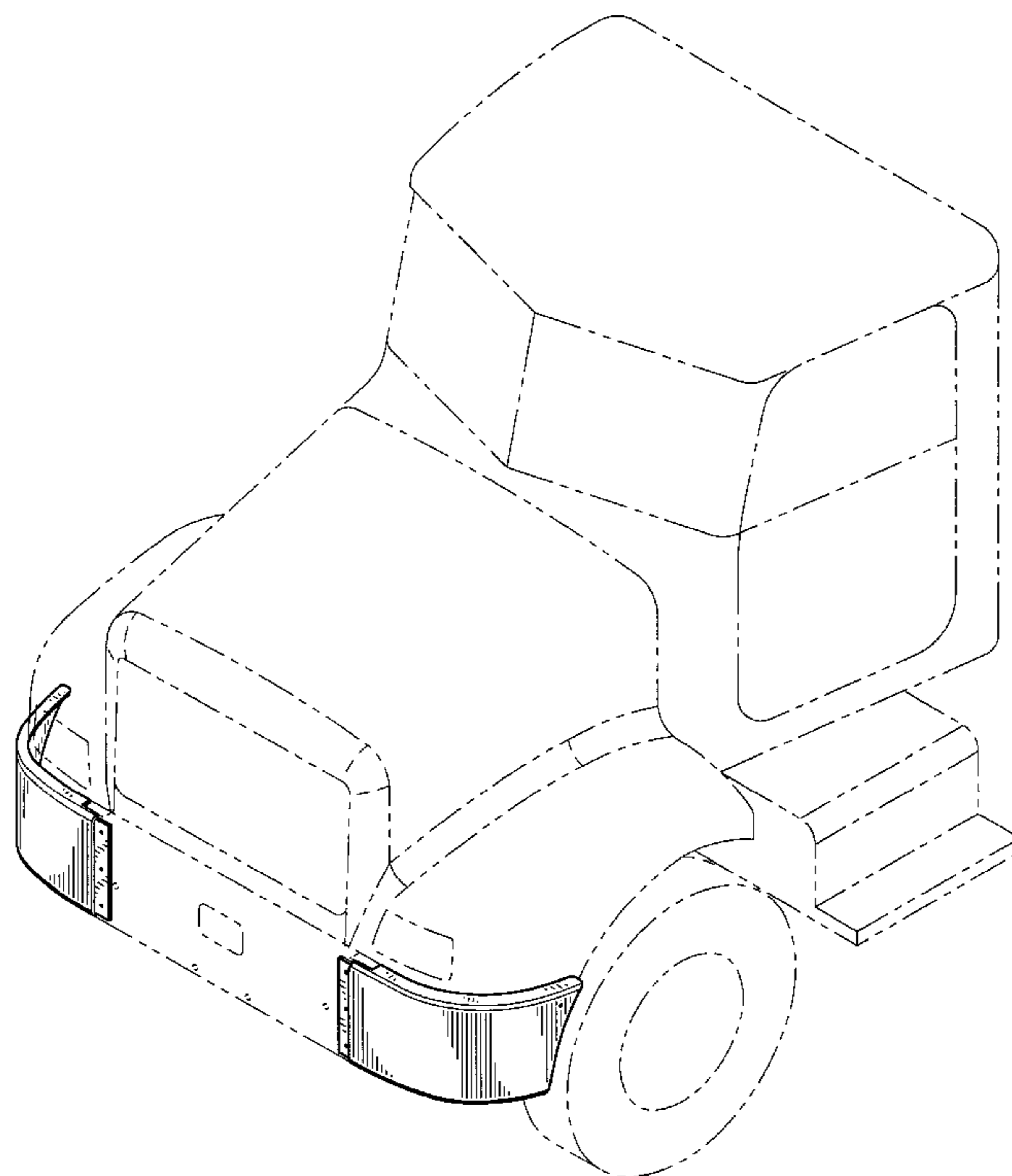

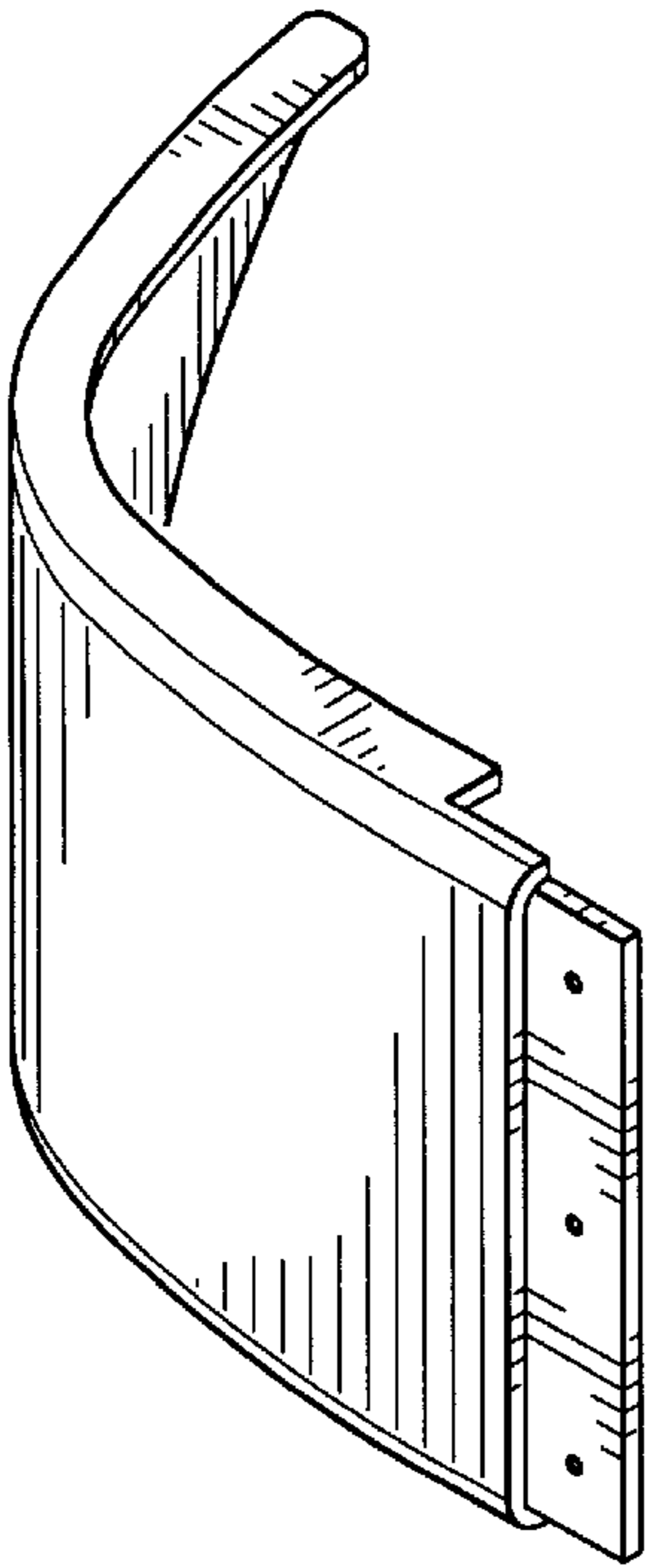

FIG. 1

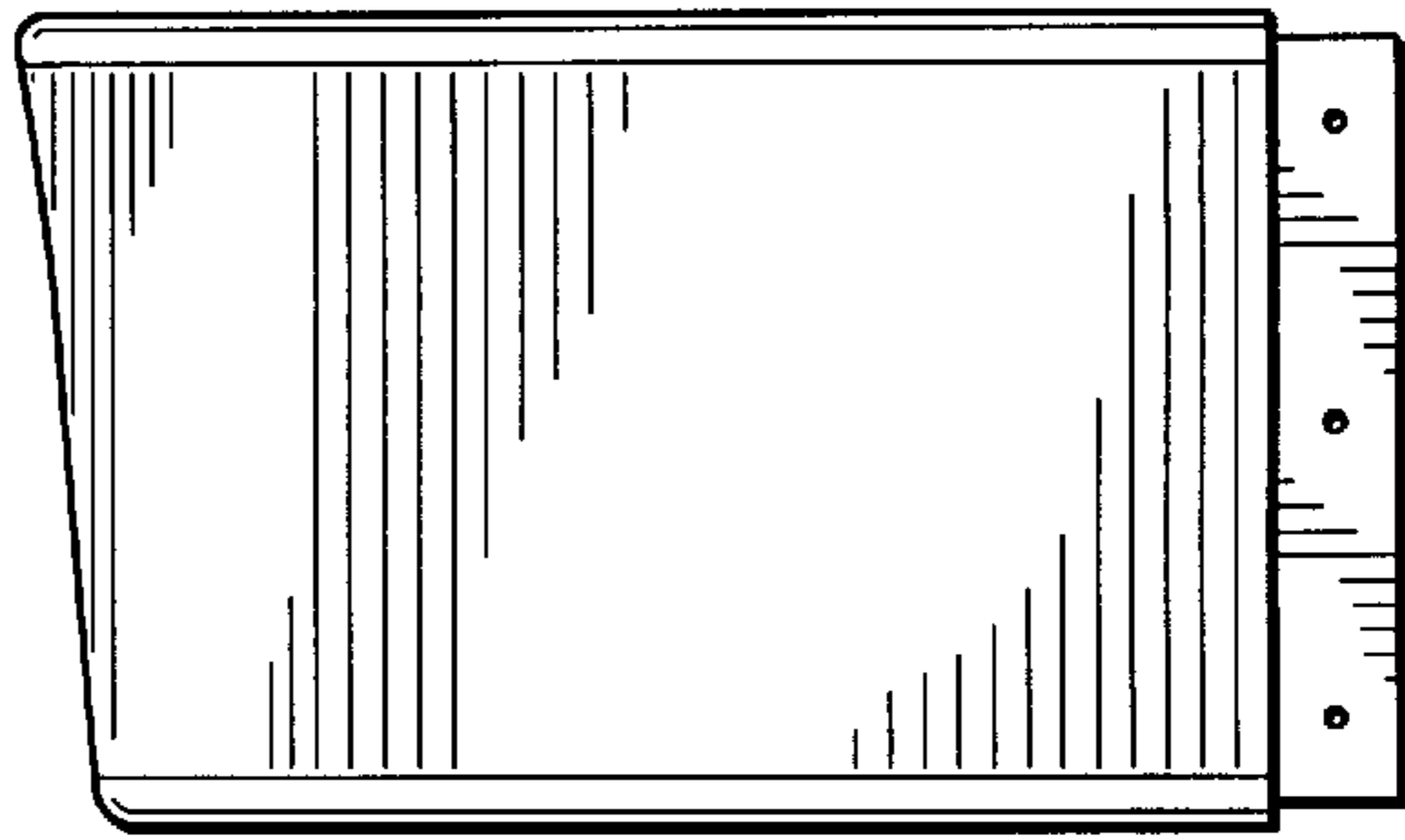

FIG. 2

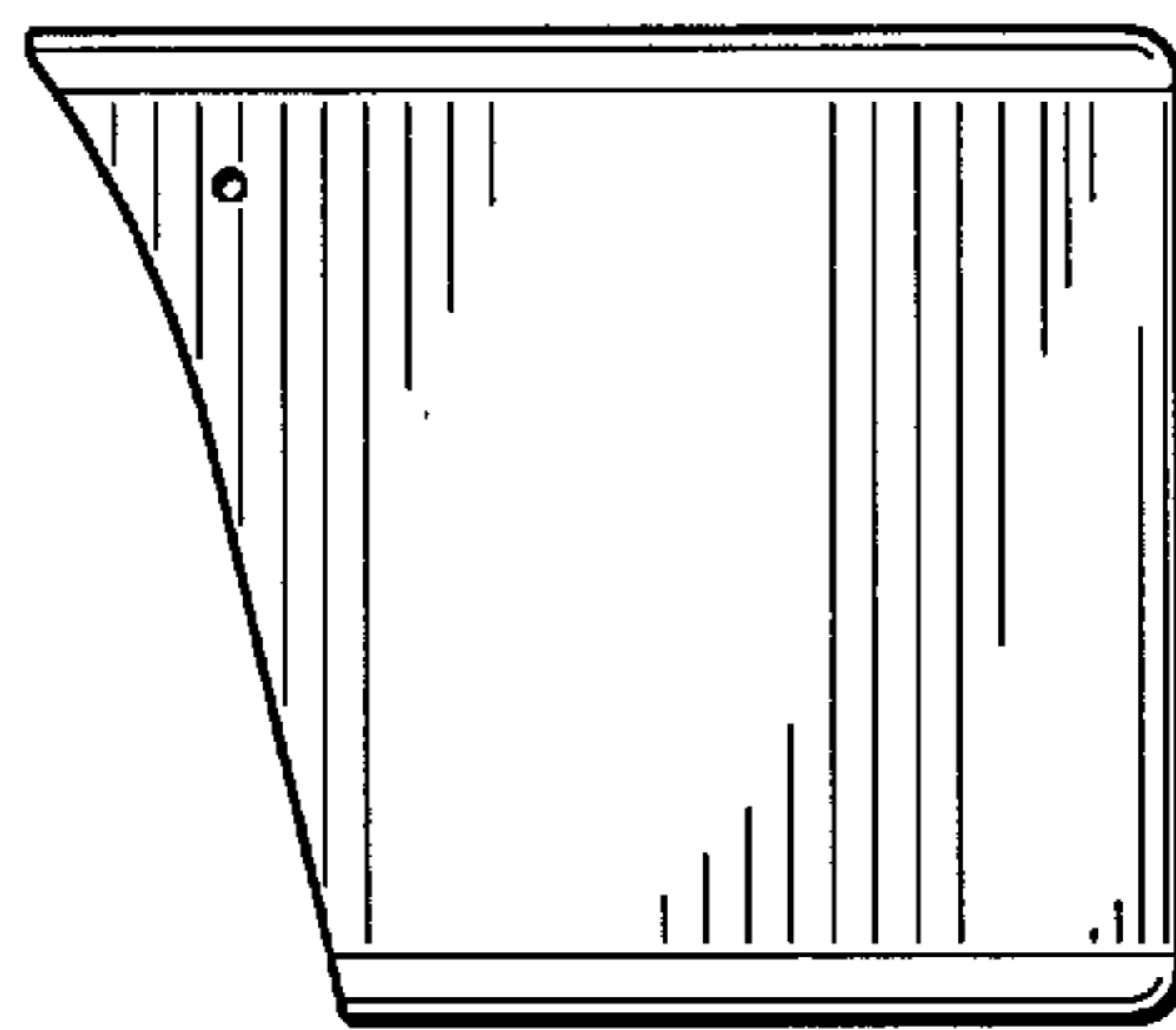

FIG. 3

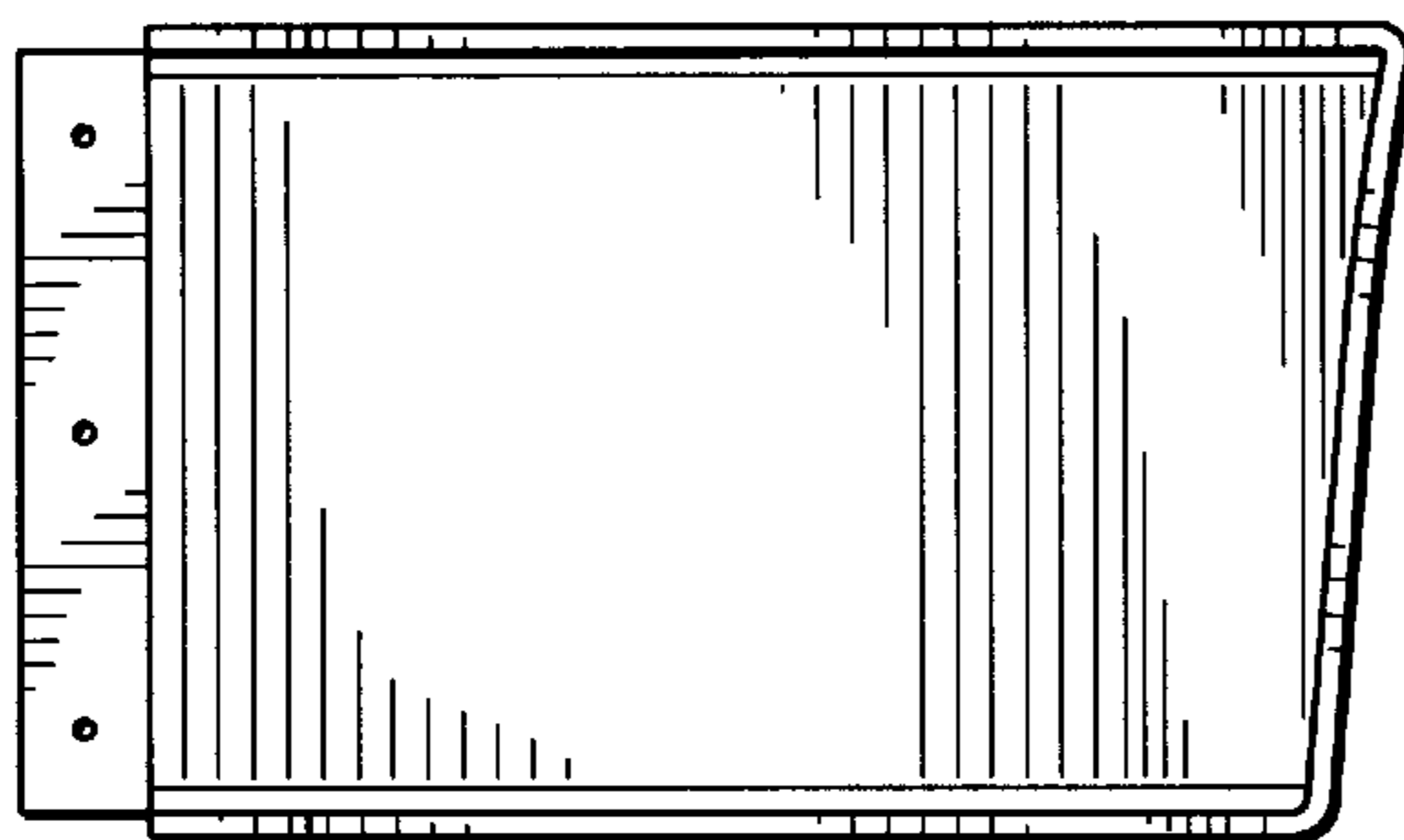

FIG. 4

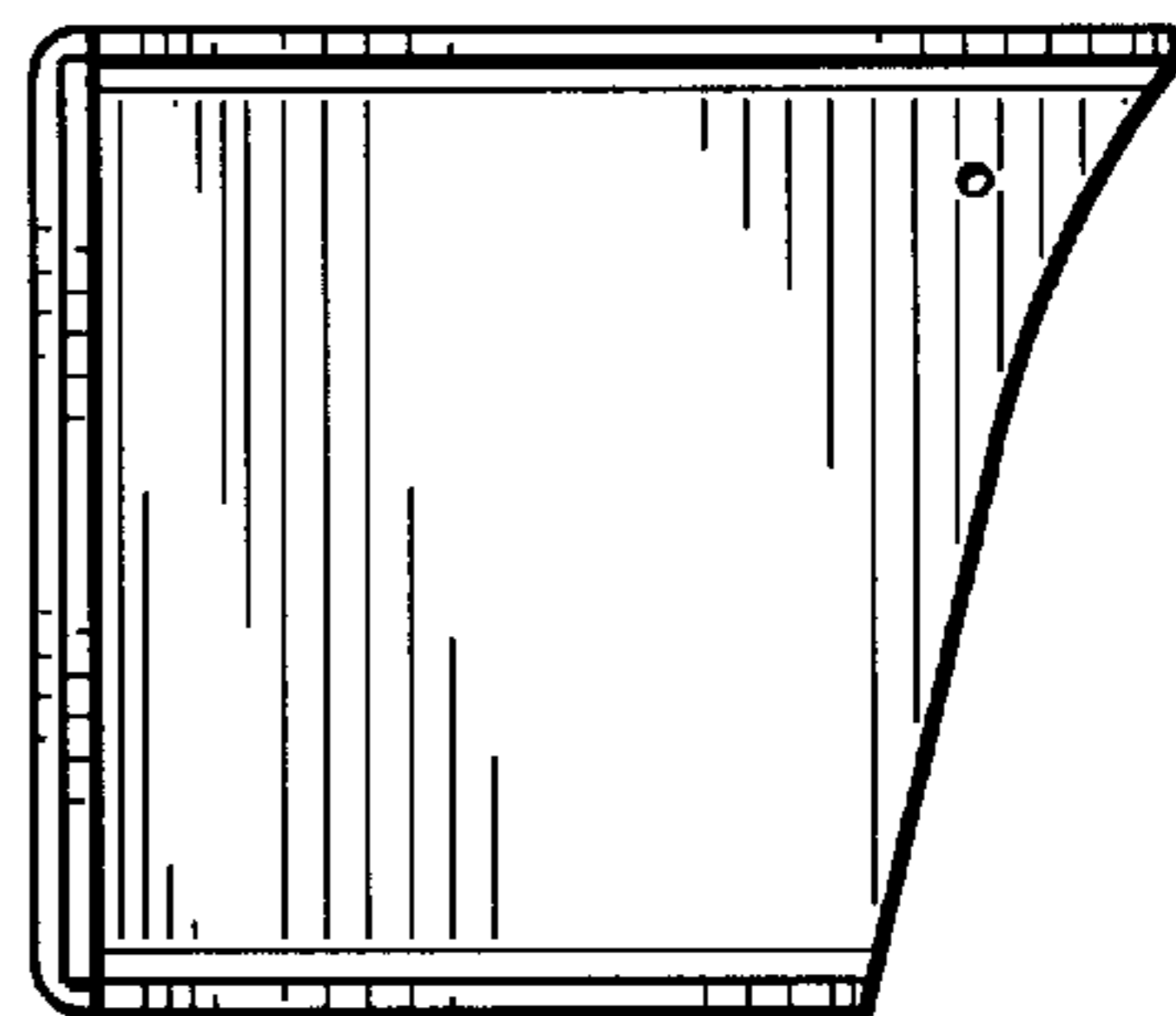

FIG. 5

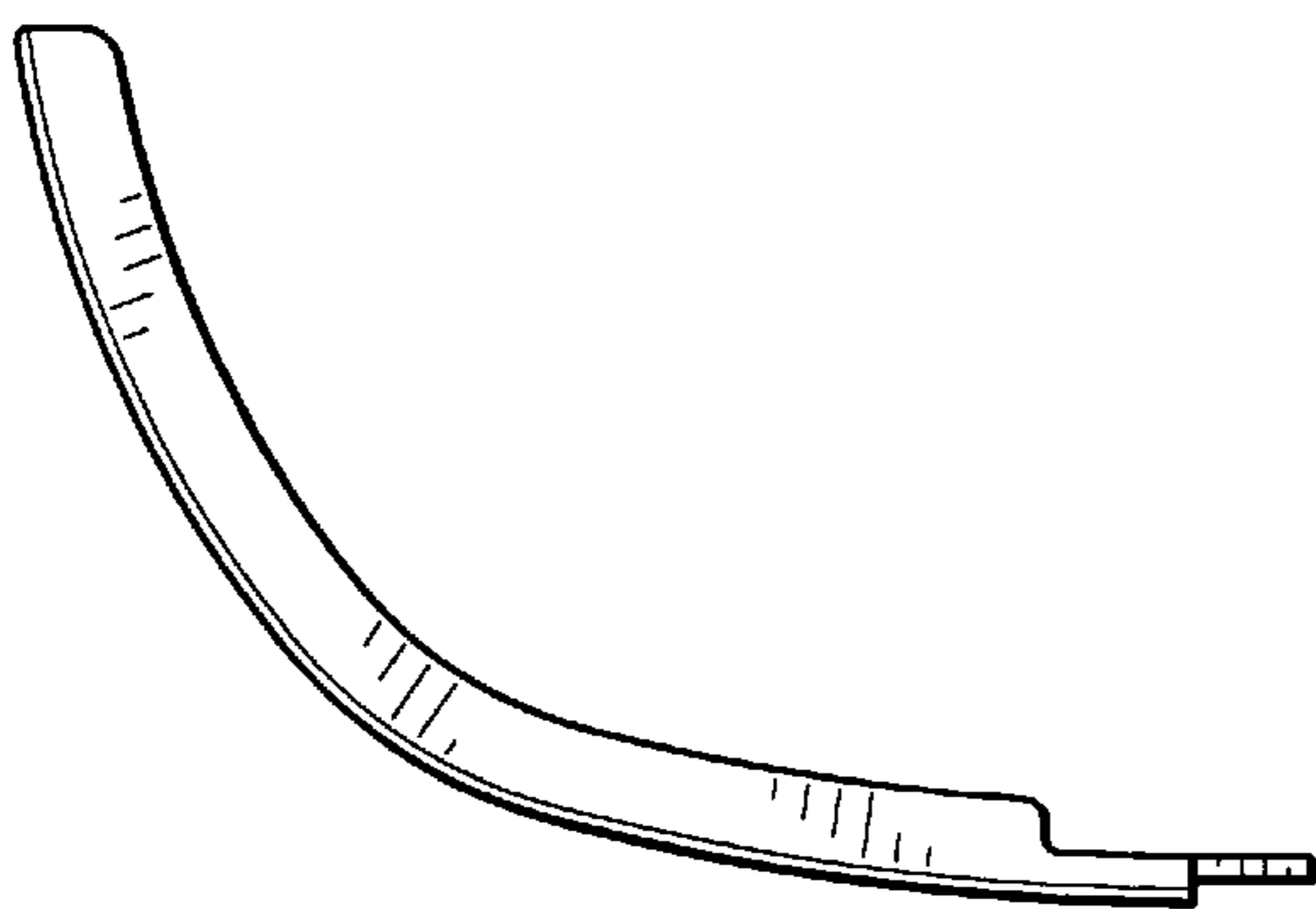

FIG. 6

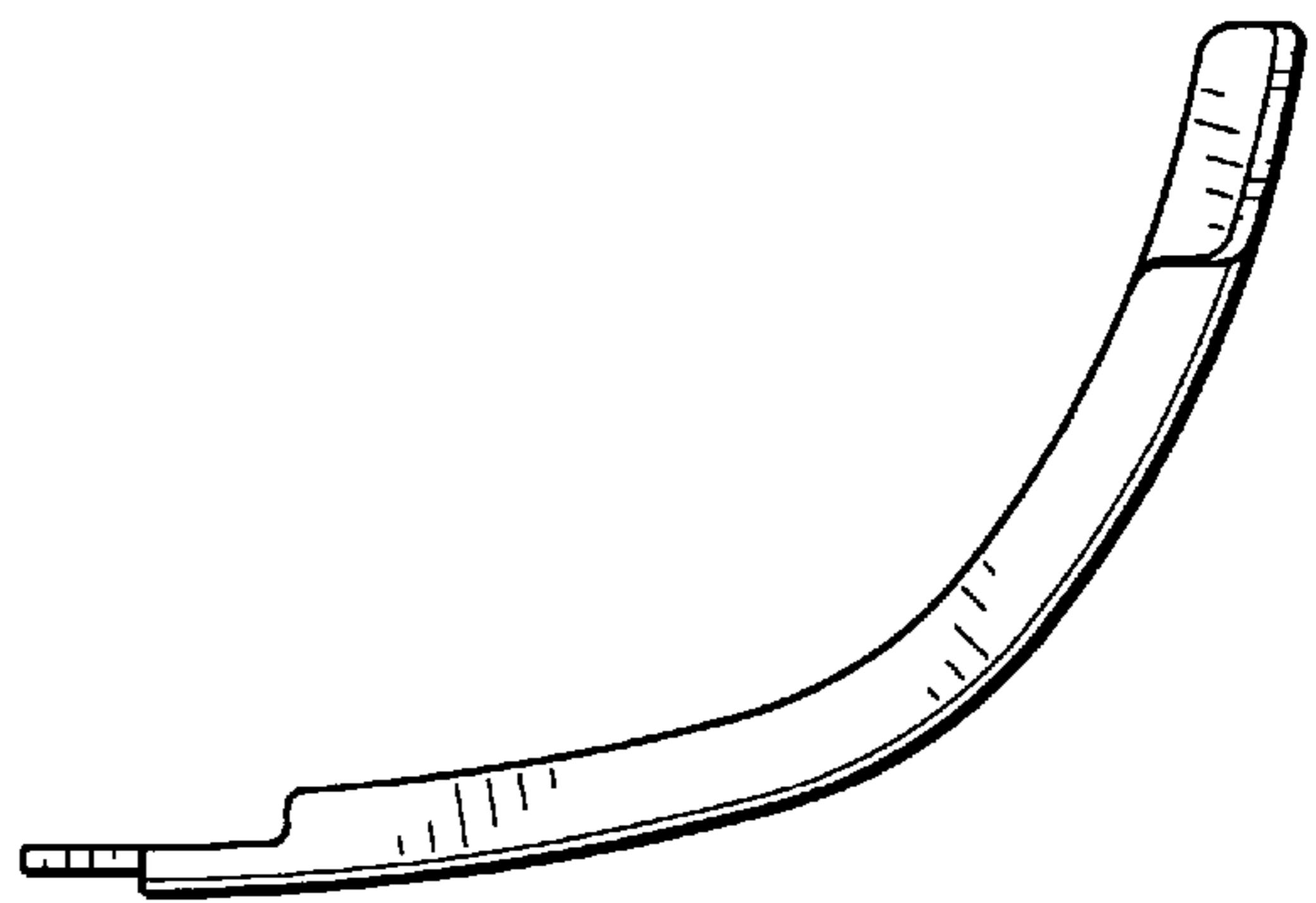

FIG. 7

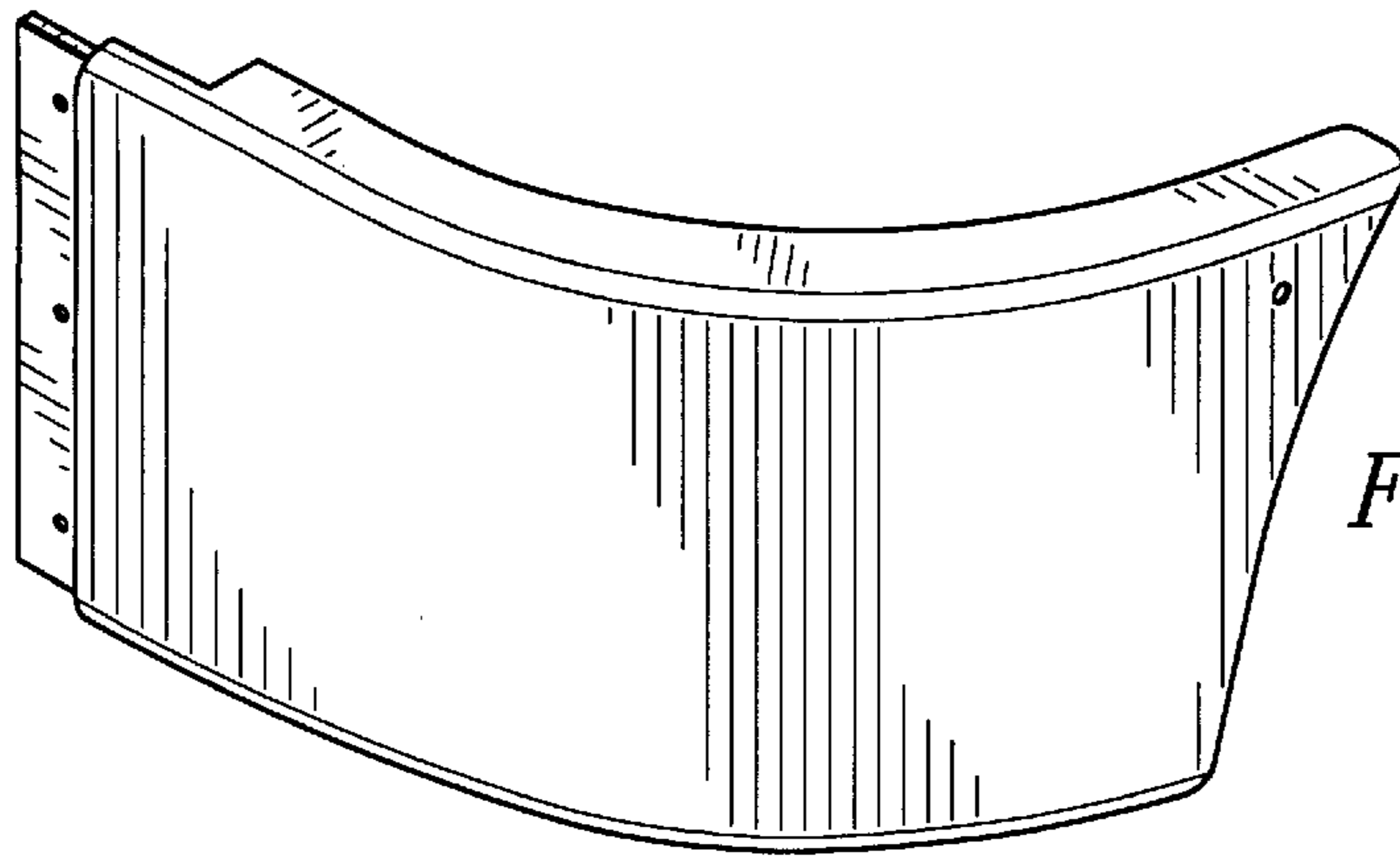

FIG. 8

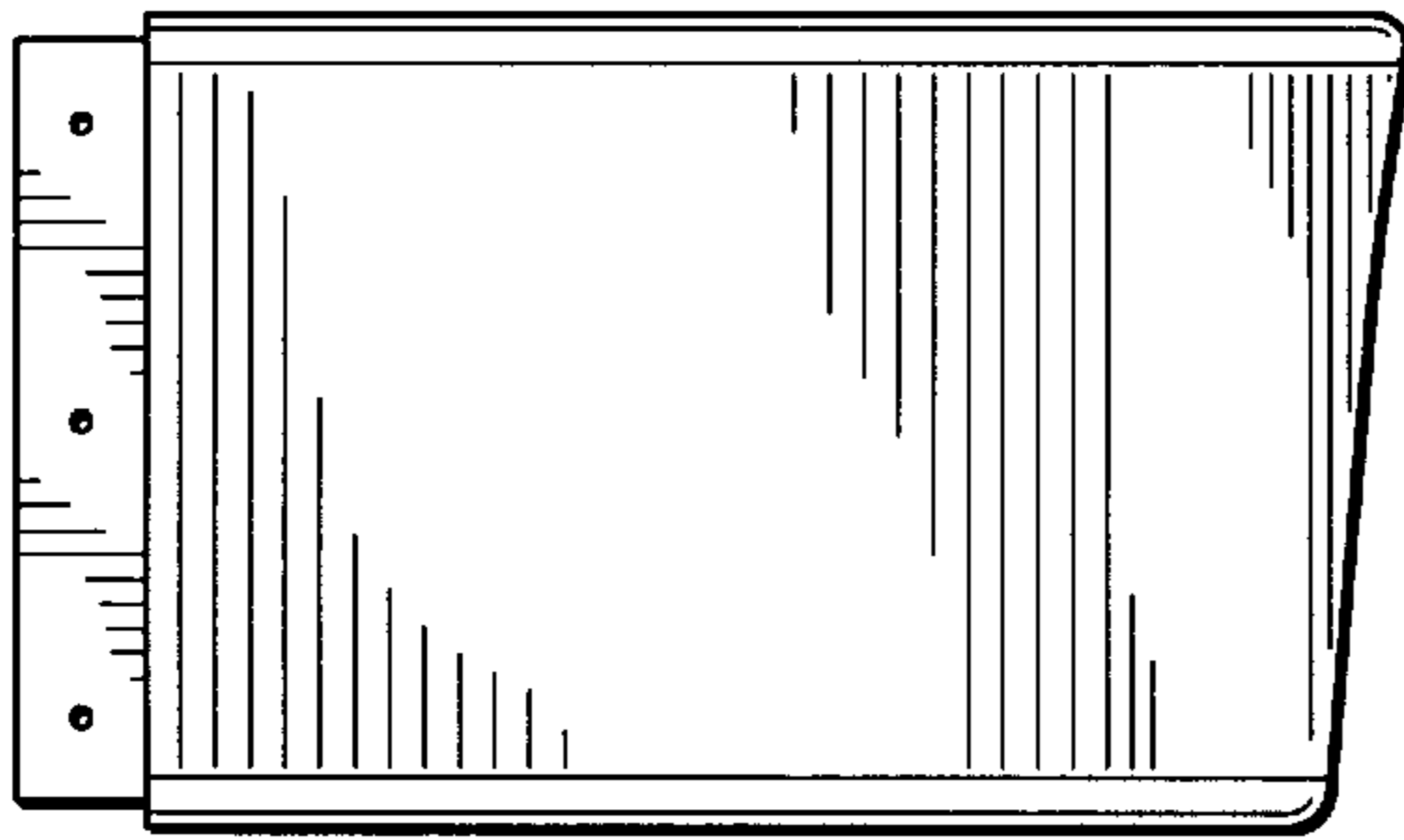

FIG. 9

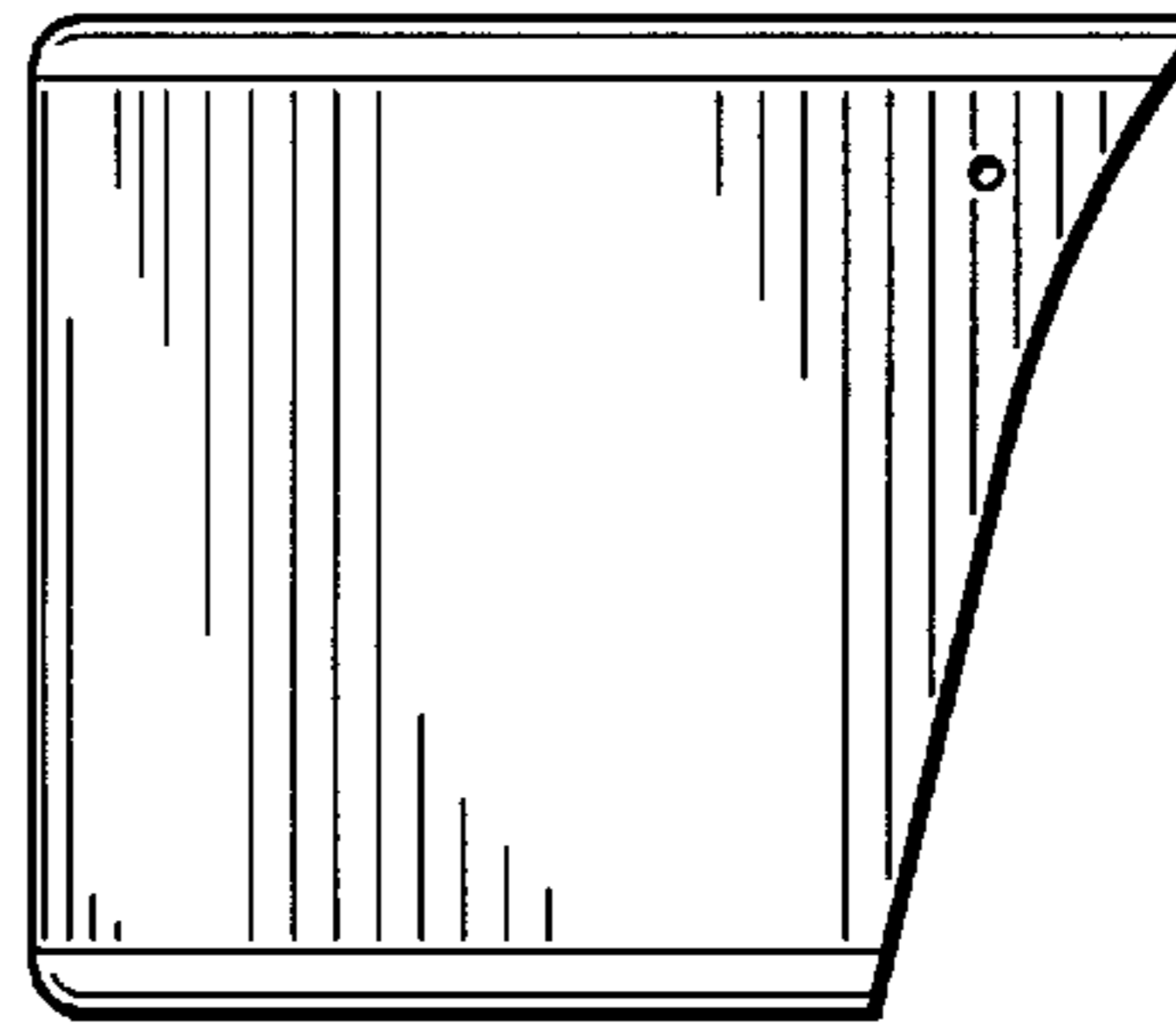

FIG. 10

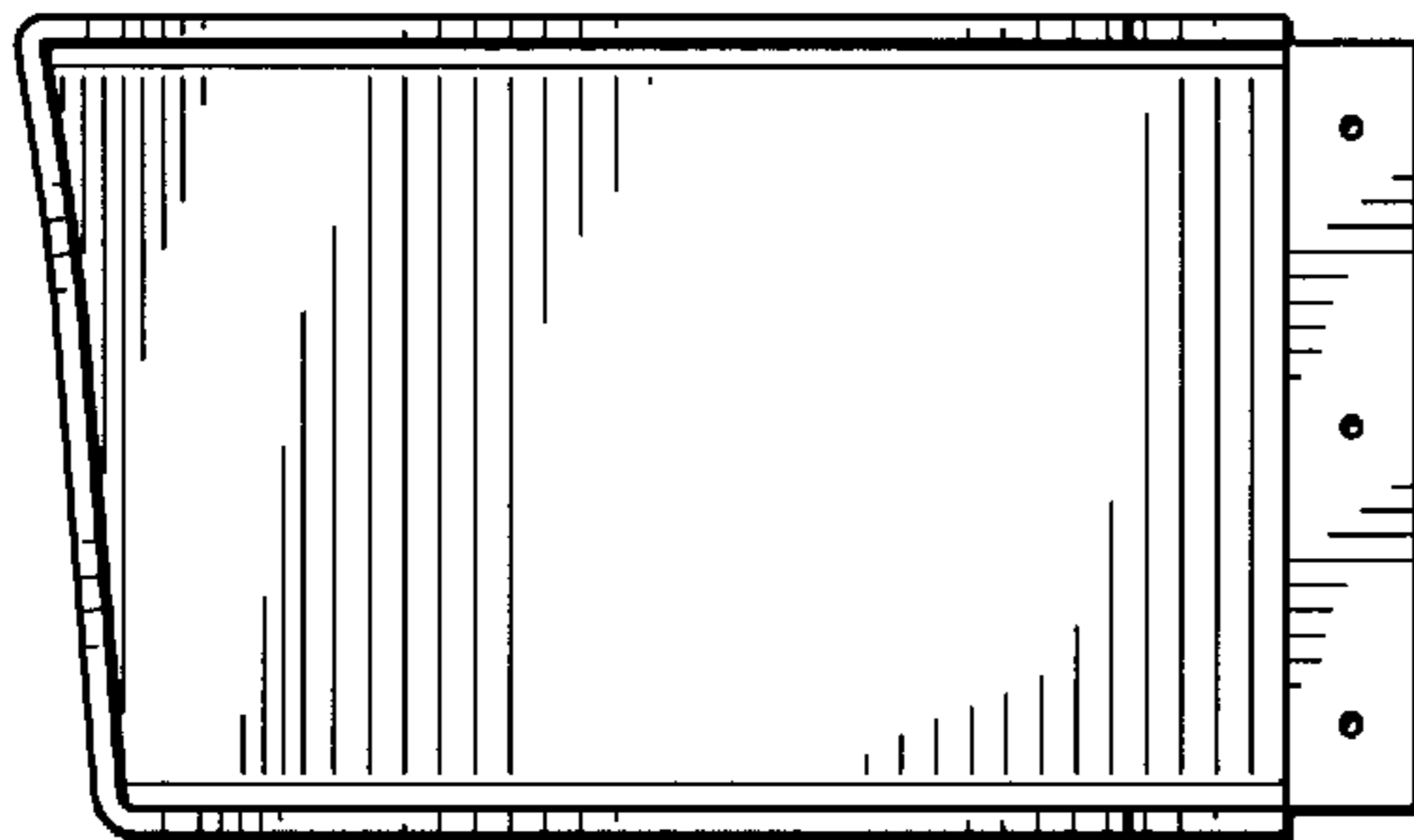

FIG. 11

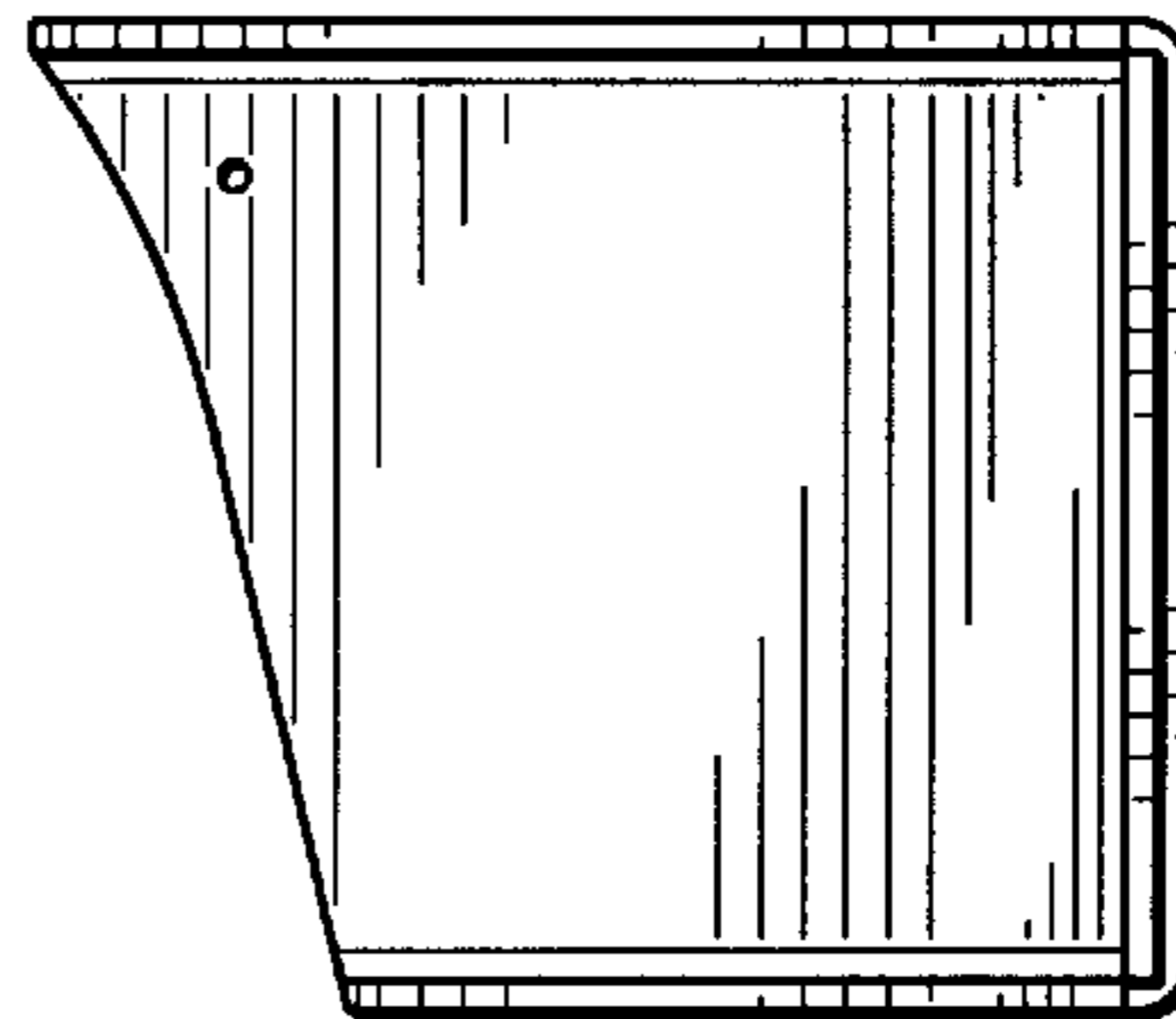

FIG. 12

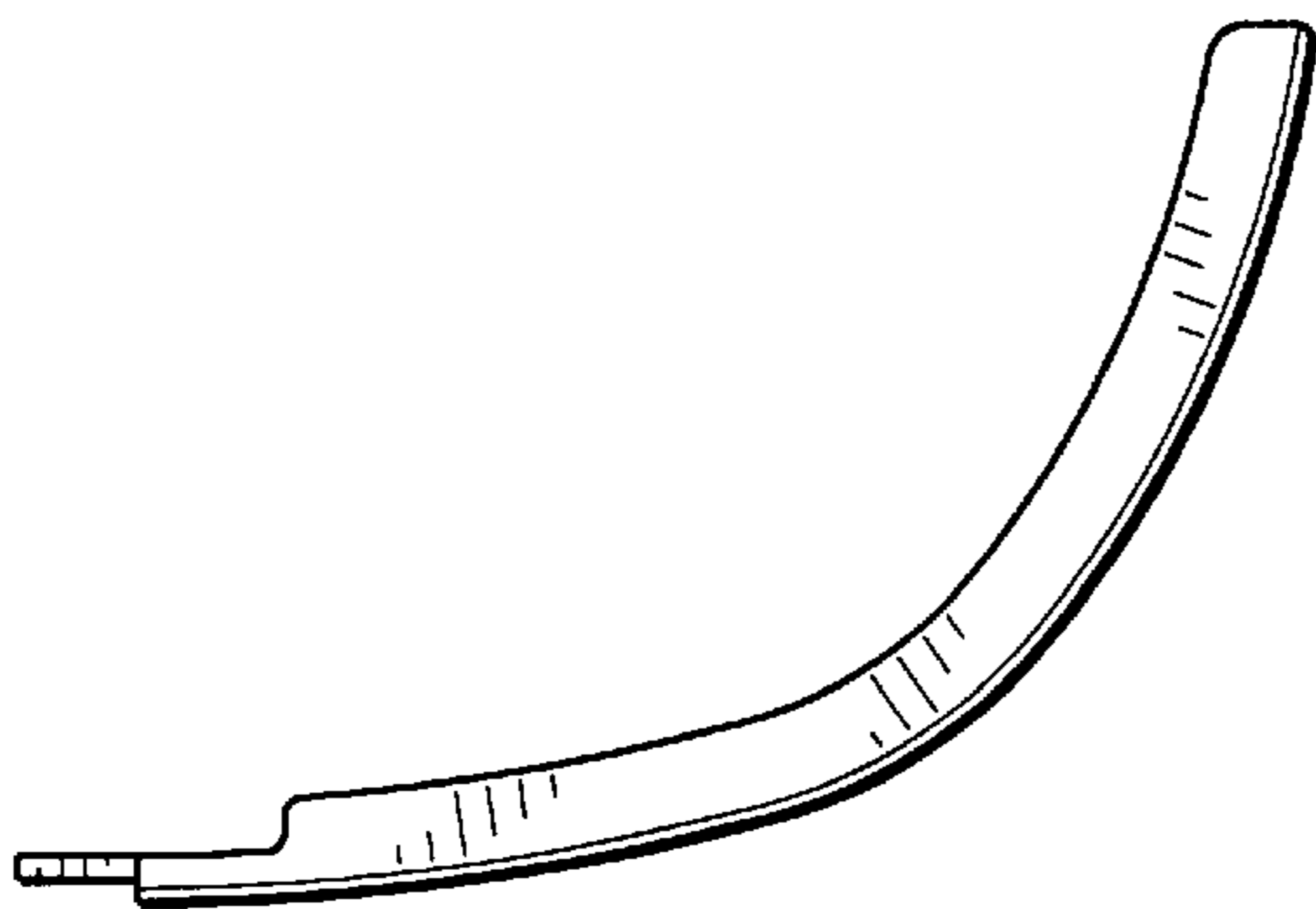

FIG. 13

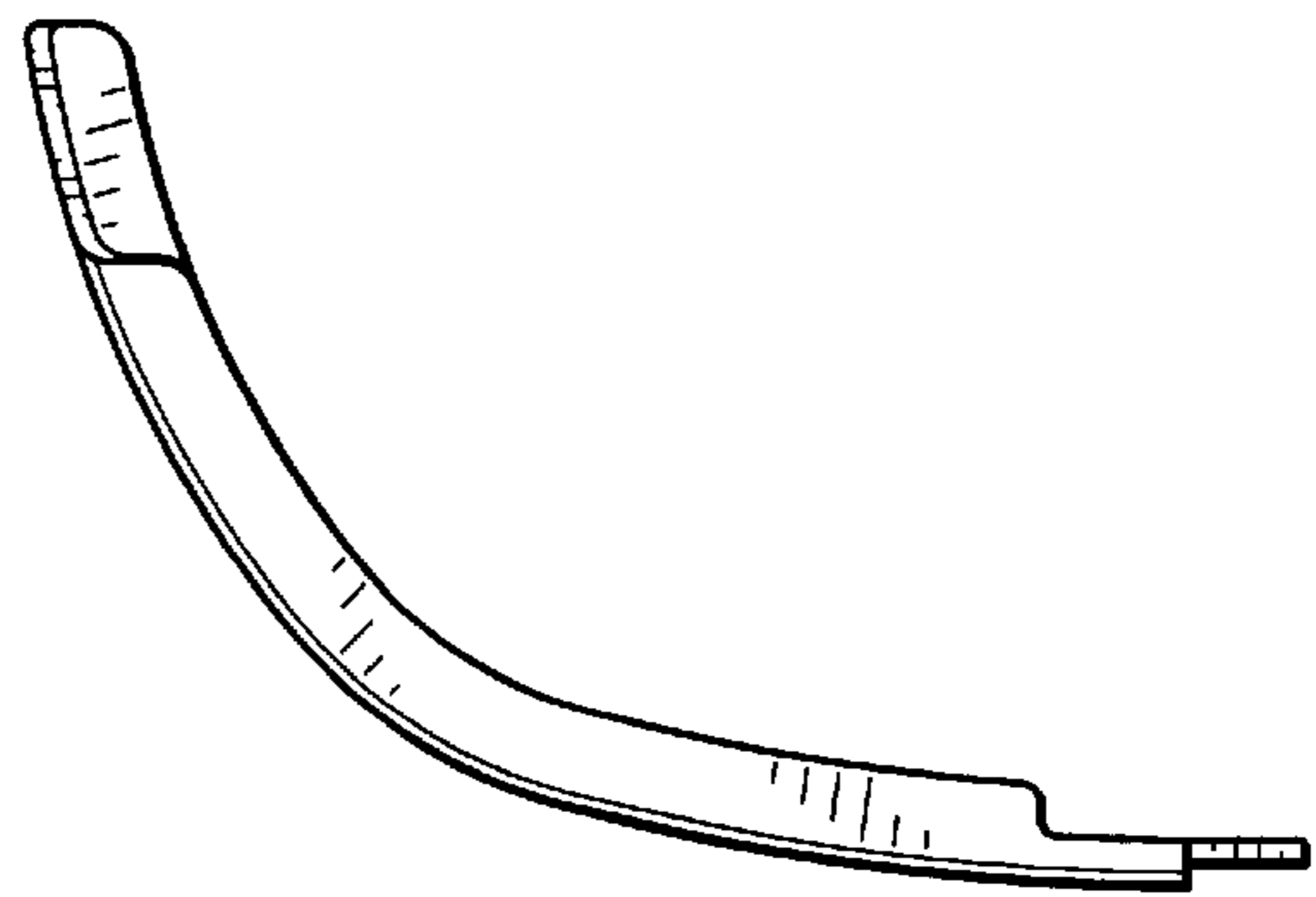

FIG. 14

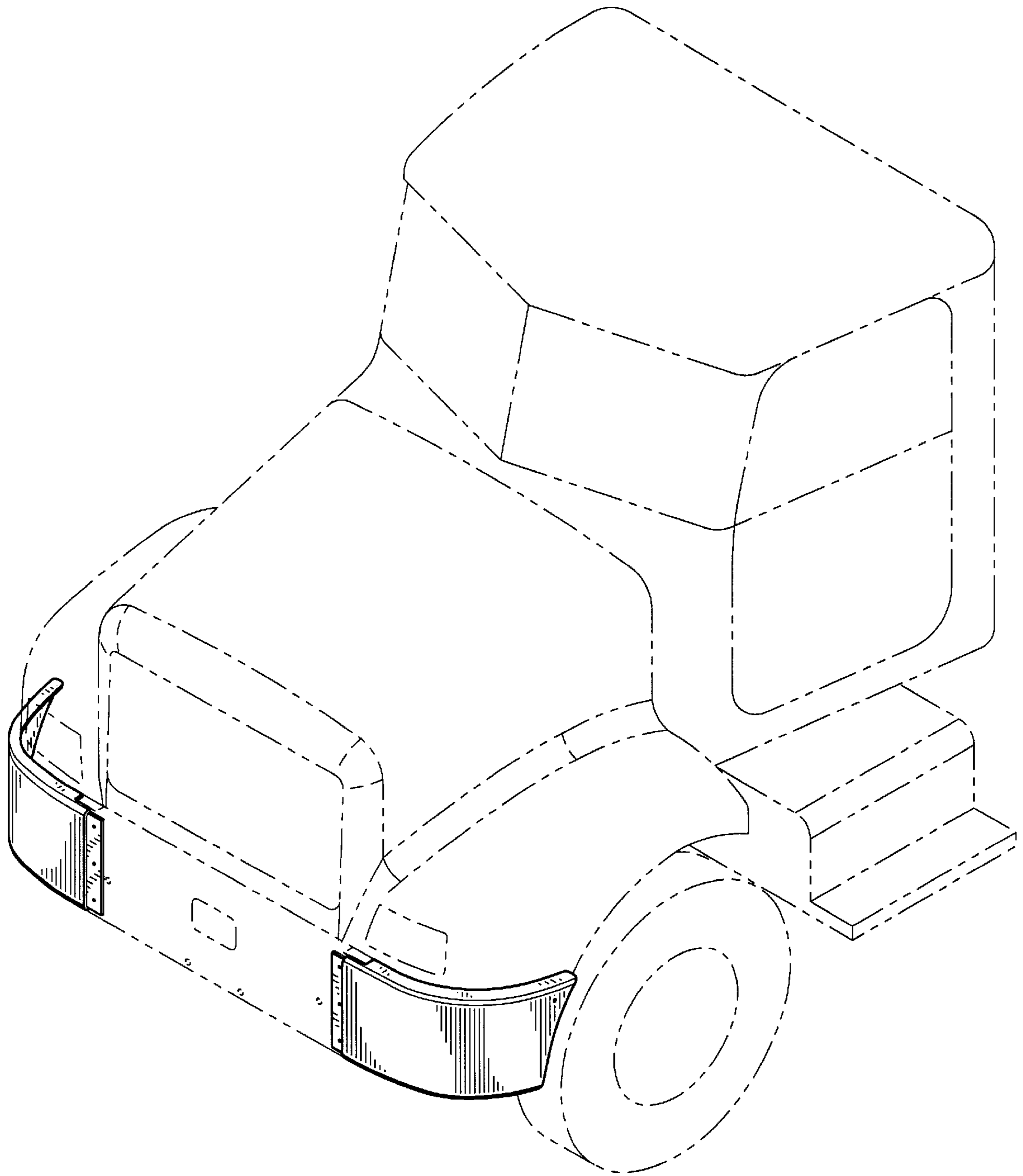

FIG. 15

UNITED STATES PATENT AND TRADEMARK OFFICE
CERTIFICATE OF CORRECTION

PATENT NO. : Des. 423,429
DATED : April 25, 2000
INVENTOR(S) : John T. HICKMAN et al.

It is certified that error appears in the above-identified patent and that said Letters Patent is hereby corrected as shown below:

DESCRIPTION

Line 4, FIG. 3, after "right", insert --side--.

Signed and Sealed this
Sixth Day of March, 2001

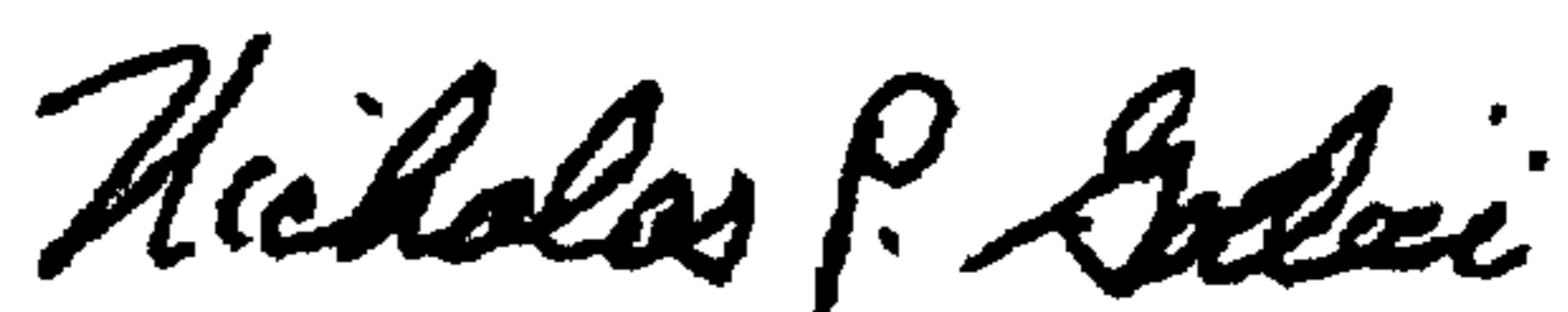

NICHOLAS P. GODICI

Attest:

Attesting Officer

Acting Director of the United States Patent and Trademark Office